

PA A P, X-270
97252

THE TREADLE PUMP
MANUAL IRRIGATION
FOR SMALL FARMERS
IN BANGLADESH

Alastair Orr
A. S. M. Nazrul Islam
Gunnar Barnes

**THE TREADLE PUMP : MANUAL IRRIGATION
FOR SMALL FARMERS IN BANGLADESH.**

First published 1991



RANGPUR DINAJPUR RURAL SERVICE

This book may not be reproduced in whole or in part
(except for purposes of review) without the express
permission of the publishers in writing

Published by RANGPUR DINAJPUR RURAL SERVICE (RDRS)

House 62, Road 7A, Dhanmondi, Dhaka-1209

GPO Box 618, Dhaka-1000, Bangladesh

Printing funded by PACT Bangladesh/PRIP
with assistance from USAID

Printed in Bangladesh by Pioneer Printing Press Ltd, Dhaka.

THE AUTHORS

Alastair Orr is an agricultural economist with Britain's Overseas Development Administration. He is currently seconded to the Bangladesh Rice Research Institute.

A. S. M. Nazrul Islam is an agricultural economist. He is a Scientific Officer in the Agricultural Economics Division of the Bangladesh Rice Research Institute.

Gunnar Barnes is an agricultural engineer. He is an Agricultural Advisor with RDRS and headed the research programme which developed the treadle pump.

PREFACE

This book has been written for all those interested in manual irrigation, but mainly for planners, engineers, and NGOs. Planners, we believe, will be chiefly interested in the ways the pump has raised the incomes of small farmers. Engineers will find a textbook example of the design of appropriate technology for small farmers, as well as full descriptions of the pump's specification and construction in a separate technical appendix. For NGOs, the treadle pump provides a case study of the development of appropriate technology. We believe the lessons learned in the design and marketing of the treadle pump may be relevant elsewhere.

This book is based on a survey of the socio-economic impact of the treadle pump made by the Bangladesh Rice Research Institute (BRRI) in the winter season of 1987/88. Subsequently, RDRS wished to publish the report for a wider audience. In revising the report for publication we have added new material and omitted much of the technical detail. Readers who wish to know more about our methods and the basis for our conclusions are invited to consult the original report. *

The book is organised as follows. Chapter 1 introduces the treadle pump and explains its success in terms of three design criteria: a high and sustainable level of output, simplicity of manufacture, and low cost. Another factor in the success of the pump has been effective marketing. In Chapter 2, we show how International Development Enterprises (IDE) created a national market for the treadle pump and examine the depth of this market. The next three chapters analyse different aspects of the pump's impact. Chapter 3 examines adoption and maintenance, and shows that the pump has been adopted primarily by small farmers and is easy to maintain. In Chapter 4, we explore the pump's impact on cropping intensity and employment. Chapter 5 measures the impact on farmers' income. Two case studies are presented in Chapter 6. Finally, the results are summarised in the conclusion.

Alastair Orr

A. S. M. Nazrul Islam

Gunnar Barnes

* Alastair Orr and A. S. M. Nazrul Islam, *The socio-economic impact of the treadle pump. Research Report # 2, Agricultural Economics Division, BRRI, September, 1988. Mimeo, 139 pp.*

ACKNOWLEDGEMENTS

We wish to thank the farmers who cooperated with us patiently for a period of over four months to provide much of the information for this book, and to our village interviewers.

We are also grateful to Hemoja Chakravorty, Abdul Malek, Thomas Kroll, Md. Anwar Hossain and Bishwanath Roy of RDRS.

For discussions and reference materials, thanks to J. L. McIntosh and Noel Magor, IRRI/BRRI Project; Frank Weibe, MCC; Stewart Bentley, MAWTS/IVS; Ms. Wahida Haq, World Bank; Q. Shahabuddin, MPO; R. Stickney, IRRI; Johnny Walker, Huntings Technical Services Ltd.; Tim Bene and Kip Warr, ULG Consultants Ltd.; and the Librarians at BRRI, BARC, BIDS, BAU, AST, and the World Bank. We also thank Bruce Currey for helpful comments on the report.

The authors wish to thank those who assisted in the task of revising the original report for publication: Kamaluddin Akbar, Merrick Lockwood, Marceline Rozario and Torben V. Petersen of RDRS, and particularly Bob Nanes of IDE who drafted the chapter on marketing.

Survey work was funded by BRRI and the United Kingdom Overseas Development Administration (ODA). The views expressed here are those of the authors, and should not be attributed to either organisation.



CONTENTS

LIST OF TABLES	VIII
LIST OF FIGURES	IX
CONVERSION FACTORS	X
BENGALI MONTHS AND ABBREVIATIONS	XI
INTRODUCTION	1
Chapter 1. THE TREADLE PUMP	7
1. 1 High output and ease of operation	8
1. 2 Simplicity of manufacture	15
1. 3 Costs	16
Chapter 2. MARKETING	21
2. 1 Production	21
2. 2 Sales	23
2. 3 Marketing	24
2. 4 The size of the market	26
Chapter 3. ADOPTION AND MAINTENANCE	33
3. 1 Adoption	34
3. 2 Maintenance	39
Chapter 4. CROPPING INTENSITY AND EMPLOYMENT	43
4. 1 Cropping intensity	45
4. 2 Employment	48
Chapter 5. INCOME	55
5. 1 Costs and benefits	55
5. 2 Income and security	59
Chapter 6. CASE STUDIES	65
6. 1 Pirganj upazila: Shopin	65
6. 2 Aditmari upazila: Debendranath	69
CONCLUSION	73
BIBLIOGRAPHY	77
APPENDIX 1: Discharge rates for the treadle pump	81
APPENDIX 2: Technical section	83

LIST OF TABLES

1.1 Discharge rates by suction depth and pump size	13
1.2 Cost of treadle pump and bamboo tubewell, 1987-88	16
3.1 Pump ownership by upazila and farm size	35
3.2 Use of treadle pump for irrigation and drinking water, by upazila	37
3.3 Source of funds for treadle pump, by upazila	38
3.4 Frequency of repairs to treadle pumpheads, by year of purchase	39
4.1 Cropping intensity on unirrigated land and land irrigated by treadle pump	44
4.2 Area of land irrigated by treadle pump and previously fallow in the <i>Boro/rabi</i> seasons, by upazila and land type	46
4.3 Number of farmers growing new crops on high and medium land after adoption of the treadle pump,	47
4.4 Family and hired labour hours operating the treadle pump, by upazila	49
4.5 Type of labour used to operate the treadle pump, by farm size	50
4.6 Employment in crop production on unirrigated land and land irrigated by treadle pump, by crop season and upazila	52
5.1 Costs and benefits of treadle pump irrigation, by crop	56
5.2 Cost-benefit analysis of treadle pump irrigation	57
5.3 Sale and consumption of crops irrigated by treadle pump	59
5.4 Number of farms buying rice in each month before and after adoption of the treadle pump, by upazila	61
A.1 Discharge rates by suction depth and cylinder size	81
A.2 Output conversions for different cylinder sizes	82
A.3 Specifications for $3\frac{1}{2}$ and $4\frac{3}{4}$ inch diameter treadle pumps	91
A.4 Specifications for $3\frac{1}{2}$ inch twin treadle pump <i>dheki</i> type	92



LIST OF FIGURES

1.	Schematic diagram of treadle pump superstructure and pumphead	11
2.	Discharge rates for treadle pump at different pumping heads and energy levels	14
3.	Major treadle pump workshops in Bangladesh, 1988	22
4.	Sales of rower and treadle pumps in Bangladesh, 1979/80-1988/89	23
5.	Schematic diagram of a treadle pump tubewell	28
6.	Maximum depth to groundwater table in Bangladesh	30
7.	Sites for BRRI treadle pump survey 1987/88	34
8.	Area required to recover cost of treadle pump, Pirganj and Aditmari upazilas	58
A1.	A traditional treadle pump	85
A2.	Design improvements to traditional treadle pump	86
A3.	Details of design improvements to traditional treadle pump	87
A4.	Design improvements to cylinder valves	88
A5.	Design improvements to plungers and their treadle and rope connections	89
A6.	Dimensions of plunger discs and cylinder bottom plates for two pump sizes ($3\frac{1}{2}$ and $4\frac{3}{4}$ inch diameter)	90
A7.	A <i>dheki</i> treadle pump	92
A8.	Cylinder and plunger rods for <i>dheki</i> pump	94
A9.	Manual boring tools in Bangladesh and stages in the drilling process.	95

CONVERSION FACTORS

Weights

1 seer = 0.934 kg

40 seer = 1 maund

1 maund = 37.38 kg

1 metric ton = 26.7939 maunds

1 chatak = 0.0584 kg

Area

1 ha = 2.471 acres

1 acre = 100 decimals

Length

1 inch = 2.54 centimetres

1 inch = 25.4 millimetres

1 metre = 3.280 feet

Volume

1 litre = 0.22 imperial gallons

1 cusec = 1 cubic foot water flow per second

1 cusec = 374 imperial gallons per minute (GPM)

1 cusec = 28.3 litres/second (l/s)

1 l/s = 0.035 cusec

Thumb rules

Acre-inch is a measure of a calculated water depth over 1 acre land area. One acre-inch means that 3630 cubic feet or 22611 imperial gallons of water has been pumped.

1 hour @ 1 cusec = 1 acre-inch

Exchange rate

The average (official) exchange rate for Fiscal Year 1988 was

\$1 US = 31.25 Taka

BENGALI CALENDAR MONTHS

<i>Boishak</i>	15 April-15 May
<i>Joistho</i>	15 May-15 June
<i>Asar</i>	15 June-15 July
<i>Srabon</i>	15 July-15 August
<i>Bhadro</i>	15 August-15 September
<i>Aswin</i>	15 September-15 October
<i>Kartik</i>	15 October-15 November
<i>Agrahayon</i>	15 November-15 December
<i>Pous</i>	15 December-15 January
<i>Magh</i>	15 January-15 February
<i>Falgun</i>	15 February-15 March
<i>Choitro</i>	15 March-15 April

ABBREVIATIONS

AST	Agricultural Sector Team (Canada)
BADC	Bangladesh Agricultural Development Corporation
BARC	Bangladesh Agricultural Research Council
BAU	Bangladesh Agriculture University
BBS	Bangladesh Bureau of Statistics
BIDS	Bangladesh Institute of Development Studies
BIRRI	Bangladesh Rice Research Institute
DTW	Deep Tubewell
EPC	Engineering Planning Consultants
FAO	Food and Agriculture Organisation
GOB	Government of Bangladesh
HTW	Hand Tubewell
IDE	International Development Enterprises
ILO	International Labour Organisation
LV	Local variety
IRRI	International Rice Research Institute
MAWTS	Mirpur Agricultural Workshop and Training School
MCC	Mennonite Central Committee



MOSTI	Manually operated shallow tubewell (STW) for irrigation
MPO	Master Plan Organisation
MV	Modern variety
NGO	Non-government Organisation
NBAW	North Bengal Agricultural Workshop
PVC	Polyvinyl Chloride
RDRS	Rangpur Dinajpur Rural Service
STW	Shallow Tubewell
UNDP	United Nations Development Programme
USAID	United States Agency for International Development
WB	World Bank

INTRODUCTION

A minor revolution is taking place in the field of manual irrigation in Bangladesh. Low-cost bamboo and PVC tubewells introduced in the late 1970s have brought irrigation within the reach of millions of small and marginal farmers for the first time. The result: record sales of manual irrigation pumps and rising incomes for some of the world's poorest farmers.

This study assesses the impact of one kind of manually operated tubewell in northern Bangladesh. The treadle pump a human-powered, twin cylinder pumphead with a bamboo or PVC tubewell – was introduced by RDRS in 1979. Since then over 185,000 pumps have been sold, making it one of the most successful irrigation pumps ever made in Bangladesh. The growing popularity of the treadle pump has attracted attention in developing countries throughout the world.

The success of the treadle pump is part of a general upward trend in sales of manual irrigation equipment in Bangladesh. This is a recent development. Until the 1970s, the extraction of groundwater in Bangladesh was made almost exclusively by motorised pumps (DTWs and STWs). Manual irrigation was largely confined to lifting surface water by traditional devices such as *dhons* and scoops. Dug wells for the extraction of groundwater covered less than 5% of the irrigated area¹. In the mid-seventies, however, the GOB introduced a programme to promote the use of hand tubewells for irrigation. The tubewells were a simple adaptation of the No. 6 hand pump used for drinking water and were known as manually operated shallow tubewells for irrigation (MOSTI). Although the pump had not been designed as an irrigation pump and was relatively expensive, within four years 88,000 MOSTIs had been sold². The programme demonstrated that there was a large, unsatisfied demand for manual irrigation equipment in Bangladesh.

The challenge of developing manual pumps specifically for irrigation was taken up by NGOs in the late 1970s. Among NGOs, there was a growing awareness of the need to make irrigation available to small and marginal farmers. The cost of the cheapest mechanical pump, the STW, put private ownership beyond the reach of all but the richer farmers. Moreover, evidence was accumulating that the benefits from mechanical irrigation were not equally distributed. Village studies painted a gloomy picture of landlords monopolising water supplies and using mechanical pumps to accumulate wealth at the expense of the poor, and criticised the choice of DTWs for irrigation as inappropriate³. Subsequent research has shown that this picture was overdrawn and that small farmers did share in the benefits from DTW irrigation⁴. Nevertheless, the need for a low-cost irrigation pump for small farmers was real enough.

Two manual pumps became available in the early 1980s. The rower pump, developed by MCC, appeared in 1980 and spread quickly in southern Bangladesh. This was soon followed by the treadle pump which spread rapidly in the north of the country. Both the rower and the treadle pumps were easier to use for irrigation than the No. 6 HTW, and much cheaper. In 1983/84, the price of a No. 6 was Taka 2,885, while the price of a rower pump was Taka 1,667 and the price of a treadle pump with a bamboo tubewell was only Taka 650⁵. With the development of low-cost models, the stage was set for a dramatic takeoff in demand for manual irrigation pumps.

Accurate sales figures for the treadle and rower pumps are not available. Estimates, which may be 10-15% either way, suggest that sales are currently running at about 65,000 a year. By 1990, it was estimated that there would be 900,000 manual irrigation pumps in Bangladesh and a further 1.3 million HTWs for drinking water⁶. Most of the recent growth in sales has come from the treadle pump. In 1988, over 60,000 treadle pumps were sold, making it the fastest-growing type of irrigation equipment in Bangladesh.

The success of the treadle pump raises questions about the role of manual irrigation in raising food production in Bangladesh. At present, the irrigation strategy pursued by the GOB is based on the rapid exploitation of groundwater resources. But this is to be achieved through expanding the number of mechanical pumps, particularly DTWs and STWs. Although the number of HTWs will rise, the simultaneous rise in the number of motorised pumps means that the proportion of land irrigated by manual methods will actually decline. In 1984, it was estimated that manual irrigation pumps covered only 0.01 % of the total irrigated area⁷.

In our view, manual irrigation complements rather than substitutes for motorised pumps. Clearly, the increase in irrigated area on which Bangladesh's future food supply depends must come chiefly from mechanical pumps because of their larger command areas. One STW can irrigate the same area as that of 50 HTWs. Moreover, operated efficiently, motorised pumps can supply water more cheaply than HTWs. Given the choice, most farmers would prefer to buy water from the owner of a STW rather than irrigate by manual methods, particularly for rice which requires continuous irrigation. Even where farmers can buy water, however, they may still prefer to maintain manual pumps in case they receive too little water, too late. Until all farmers have timely and adequate access to groundwater from motorised pumps, there are strong arguments for promoting manual irrigation⁸. Moreover, treadle pumps may be more efficient than STWs to irrigate *rabi* crops like vegetables which require only intermittent irrigation. As farms become smaller and agriculture moves towards irrigated, high-value crops, treadle pump irrigation is likely to spread.

Equity : Farmers in Bangladesh are not a homogeneous group but are endowed with different resources of land, labour and capital. Irrigation technology should reflect this diversity. In short, for each technology there is a niche. The target group for STWs is larger farmers with their own capital and ready access to institutional credit. In 1987/88, the cost of a STW on the private market was Taka 27,000 (\$ 864).⁹ This is far beyond the purse of most farmers in Bangladesh. Typically, private buyers of mechanical pumps are drawn from the rural elite. A survey of STWs in south-west Bangladesh showed that owner/managers of STWs cultivated 3 ha of land¹⁰. At present, however, 70% of farm households cultivate less than 1 ha¹¹. Clearly, a strategy based solely on private sales of STWs effectively excludes the vast majority of farmers from private ownership of irrigation pumps. Small farmers like these, farming under 1 ha of land and with large reserves of family labour, form the obvious target group for manual pumps.

Employment : Most Bangladeshis make their living from agriculture. Yet farming can no longer absorb the rapidly growing population. It is estimated that crop production can absorb only a third of the increase in the rural labour force during the Third Five – Year Plan (1985-1990)¹². Thus, there is an urgent need to increase rural employment. Manual irrigation offers a means of absorbing surplus labour not just in irrigation and increased cropping intensity but in producing and servicing manual pumps which can be made in village workshops.

Efficiency : Farms in Bangladesh are small and fragmented into several scattered plots. Manual pumps with small command areas are more suitable for such farms than motorised pumps with large command areas. DTWs, for example, have command areas of 60 ha. Cooperative management was seen as a method of using DTWs efficiently. On purely technical grounds and working under optimal operation conditions, it can be shown that there are economies of scale with large equipment. In practice, however, the average command area of a DTW is only a small fraction of potential. Private ownership avoids this problem. Farmers are better able to control the timing and distribution of irrigation water and reduce delays due to mechanical breakdowns. Manual pumps also use water more efficiently than motorised pumps. This makes them particularly suitable for high value *rabi* crops like tobacco, vegetables, and spices which require intermittent irrigation.

There is, therefore, great potential for manual irrigation in Bangladesh. Now that low cost models are available, sales of manual pumps are likely to grow rapidly. By the turn of the century, 83% of farms in Bangladesh will be under 1 ha¹³. This suggests a growing demand for irrigation technology which matches the needs and resources of small farmers. We believe that the treadle pump is appropriate to these needs and can make a major contribution to equitable growth in agriculture in Bangladesh.

REFERENCES

1. C. Edwards, S. Biggs, and J. Griffith, *Irrigation in Bangladesh: On Contradictions and Underutilised Potential*. University of East Anglia, England. Development Studies Paper No. 22. February, 1978. p. 14
2. FAO/World Bank, Bangladesh Hand Tubewells II Project Preparation Mission. Report of the FAO/WB Project Investment Centre. 27 June, 1985, p. 8.
3. B. Hartmann and J. Boyce, *A Quiet Violence*, University Press Limited, Dhaka, 1983. Chapters 19 and 20.
4. S. A. Khan, *The State and Village Society. The Political Economy of Agricultural Development in Bangladesh*. University Press Limited, Dhaka, 1989. Chapter 4.
5. FAO/World Bank, 1985, p. 10.
6. Ibid, Annex 2, p. 16.
7. Ibid, p. 10.

8. C. Edwards et. al., *passim*.
9. D. Gisselquist, *Bangladesh Minor Irrigation Subsector Study: Economic and Administrative Issues*, World Bank, Dhaka, 1989, p. 119, Table 8.
10. M. A. Hamid, M. K. Mujeri, M. R. Hasan, M. R. Islam, and M. S. Islam, *Shallow Tubewells under IDA Credit in North West Bangladesh. An Evaluation Study*, Department of Economics, University of Rajshahi, December, 1982, p. xxii.
11. GOB, *Bangladesh Census of Agriculture and Livestock, 1983-84*, vol 1: *Structure of Agriculture Holdings and Livestock Population*. BBS, Dhaka, May 1986, p. 34.
12. M. Muqtada, "Determinants and possibilities of employment expansion in the Crop Sector." In F. Islam and M. Muqtada eds., *Bangladesh, Selected Issues in Employment and Development*, ILO, Geneva, 1986. p. 67.
13. R. Ahmed, "A structural perspective of farm and non-farm households in Bangladesh", *Bangladesh Development Studies*, vol. XV, No. 2 (July, 1987), p. 107 Table VI.

THE TREADLE PUMP

The treadle pump is a classic example of the successful design of appropriate irrigation technology for small farmers. As such, the story of its development is likely to interest not just engineers but also administrators and planners concerned with improving the incomes of the rural poor. In this chapter, we provide an overview of the pump's origins, operation, and manufacture. It is not a technical treatise; detailed specifications of the components of the treadle pump can be found in a separate appendix. Here, our objective has been to describe how the treadle pump was designed around three important criteria:

- a high and sustainable level of output;
- simplicity of manufacture; and
- low cost.

Together, these features explain the attractiveness of the treadle pump for small and marginal farmers.

The treadle pump was developed by RDRS, an NGO founded in 1972 to provide relief to refugees returning to Bangladesh after the War of Independence. The emphasis on relief soon changed to one on self-help. In 1976, RDRS agreed on a five-year programme with the GOB. The objective of the agriculture programme was defined as "research, development, and extension in order to improve the existing crops, introduce new crops, and increase the effective usage of arable land"¹. Efforts to increase the area under wheat and vegetables in the dry winter season, however, convinced RDRS of the need for a low-cost irrigation pump. This soon became the priority in their agricultural programme.

It is significant that the treadle pump was developed by an NGO, and that the need arose directly out of field experience. The record of government research institutes in developing new technology has been

disappointing. A survey in 1984 revealed that out of 40 different types of agricultural machinery developed or adapted in Bangladesh, only 20 were commercially manufactured, and none of these had been developed by formal research institutes². All too often, technology has been designed in a vacuum without due consideration being given to whether anyone needs or wants it or can afford to buy or use it. By putting the farmer first, RDRS had the secret of a winning design.

1.1 HIGH OUTPUT AND EASE OF OPERATION

The first design criterion was a pump that was easy to operate and had a sustainable output good enough for at least 0.5 ha of irrigated wheat³. The search for an acceptable model took three years. How the design evolved makes a fascinating story.

RDRS began with the concept of a foot-operated pump. This decision was made because leg muscles are stronger than arm muscles, and tire less easily. Their first design, in 1976, was a pedal operated pump which used a bullock cartwheel as a flywheel to operate a single cylinder pumphead. Although the pump gained some popularity, it was expensive and had a low output because it used only one cylinder and the operator used only one leg to work the pedal.

The next design resembled a see-saw with an operator at each end. This time, the pumphead used two cylinders. Again, however, the operators stood with one foot on the ground. The effect was to tire the idling leg of the operator as much as the working leg, and the pump had little appeal to farmers. A third device had the two cylinders placed in a Y-shape on top of the suction pipe. The cylinders were buried in the ground. The plungers, of a special and more efficient design, were operated by a foot and hand-driven rocking frame. Once more, the operator used just one leg, but the use of both hands to help the foot was a significant improvement. The pump started gaining popularity.

Finally, in 1980, the idea came of using a stirrup device to allow both feet to operate the pump. Credit for this belongs to Dan Jenkins, a USAID engineer, who visited Gunnar Barnes of RDRS in Rangpur in November of that year. The stirrup pump was never made, it remained an idea. But it was like the key to a jigsaw puzzle: once found, all the other pieces fell neatly into place. Shortly afterwards, the two engineers designed and assembled the first treadle pump, using the components already developed for the Y-pump and adding the pulley and rope.

The new pump was foot-operated, it had two cylinders, and used treadles connected with a rope to engage both the operator's legs and full body weight. When it was installed among other models on the roadside, the new pump immediately attracted passing farmers in a

way the other pumps had not. They sized up the ease of operation, the output, the price tag, and demanded their own specimen. In one day, recalls Gunnar Barnes, 50-60 farmers visited his office requesting pumps. The long search for a manual pump was over.

Operation

The treadle pump is a foot-operated irrigation pump which uses a bamboo or PVC tubewell to extract groundwater. Essentially, the pump has three parts:

- a metal pumphead;
- two bamboo treadles and a bamboo frame; and
- a bamboo or PVC pipe and strainer.

Pumphead

The pumphead has two parts:

- twin (two identical parallel) cylinders of sheet metal welded together with a suction inlet at the bottom; and
- two plungers with rope and pulley.

The diameter of the cylinders varies in order to fit existing "buckets" (piston seals) and to provide suitable outputs of water. The most common model has $3\frac{1}{2}$ inch diameter cylinders. The cylinders are joined together at the base by a junction box, which connects through check valves to the suction pipe.

Figure 1 shows how the pumphead works⁴. Water penetrates the filter and rises up through the suction pipe to the dynamic ground water level. From there it is lifted in a pulsating stream following the strokes of the two pistons. The action of the two cylinders provides a virtually continuous stream of water. This makes the treadle pump more efficient than single cylinder pumps, where energy is needed to re-accelerate the water column after the longer pause in the change-over between strokes.

On the upward pumping stroke, the piston valve is closed. Water is sucked up through the pipe and into the cylinders. At the base of each cylinder is a foot-valve, called the check valve. The check valve is a simple rubber flap or disc made from an old truck or tractor tyre. As the water flows upwards, the check valve opens to allow passage into the cylinders. The water is drawn by the piston almost to the top of the cylinder. Simultaneously, water from the previous stroke is expelled from the cylinder to the field channel. If the cylinder rim is set correctly at ground level there is no energy loss or erosion during this expulsion.

On the downward pumping stroke, the piston valve is open and the cylinder check valve is closed. The piston travels through the water from

the top to the bottom of the cylinder. The closed check valve directs the water from the suction pipe (rising main) to the other cylinder.

The plunger is a metal rod onto which are welded or riveted two round, metal discs. A moulded plastic cap or "bucket" is sandwiched loosely between the two discs. The upper disc has holes which allow water to pass through. On the downward pumping stroke, the plunger is forced down the cylinder. The "bucket" moves off the lower disc, allowing water to flow up through the holes in the upper disc. On the upstroke, the bucket acts as a seal and creates a vacuum to suck up water into the cylinder.

Superstructure

The superstructure is shown in Figure 1. The two treadles are connected together with the two plunger rods by a rope which passes over a wooden pulley or wheel. Many farmers have modified the original design, however, and operate the treadle pump without a pulley. This is known as the *dekhi* system since it resembles the indigenous rice-hulling device of the same name. Many farmers find the *dekhi* system easier to operate since there are fewer moving parts. Other farmers continue to use the pulley system, taking advantage of its higher output and, following recent improvements, smoother operation. Some farmers have replaced the jute rope for the pulley with a bicycle chain.

The two treadles have a common fulcrum pin (known as the "long pin"). The treadles are long enough (ideally 2 m or 7 ft) to allow the operator to increase leverage by moving backwards or to accommodate a second operator. The treadles are long enough to accommodate two adults or four children. A bamboo frame allows the operator to balance himself and rest while pumping.

Pipe

The junction box at the bottom of the pumphead is connected to a suction pipe. At first, treadle pumps were generally used with a 9 m (30 ft) bamboo as a suction pipe. The lower end of the bamboo is fitted into a strainer which prevents sand blocking the suction pipe. The strainer is made from strips of bamboo fastened together into a hollow tube and covered with plastic sacking.

While bamboo continues to be common for the tubewell in northern Bangladesh, elsewhere PVC pipes and filters have become popular. Although they cost more, they have several advantages. Farmers prefer the permanence of PVC or steel pipes over a bamboo tubewell, which will rot in 4-5 years. Simple and fairly cheap chemical treatment will extend the life of a bamboo tubewell to about 15 years. Moreover,

SUPERSTRUCTURE

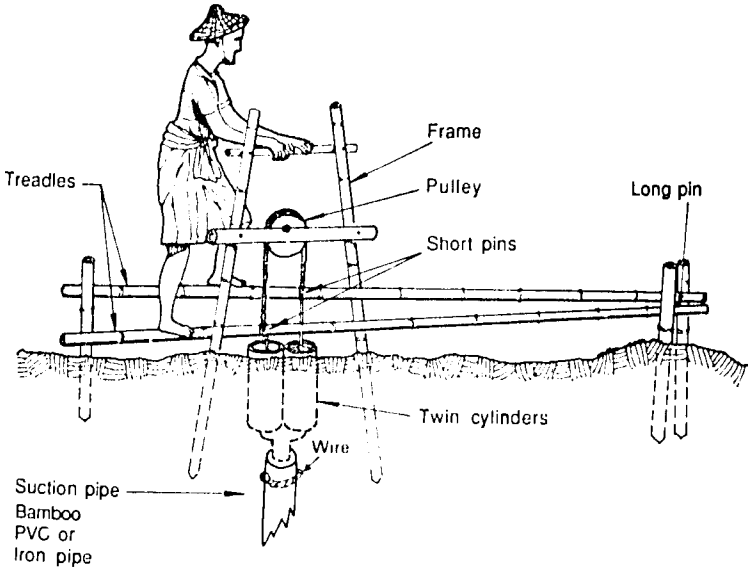

PUMPHEAD

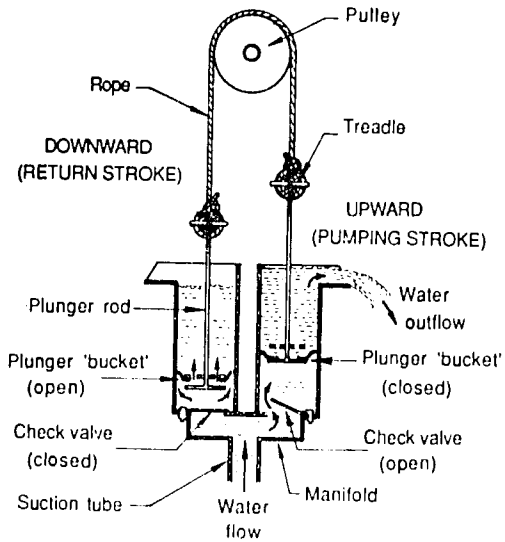

Figure 1 : Schematic diagram of treadle pump superstructure and pumphead

PVC pipes have less chance of leakage, and give higher output because losses from friction are reduced. It is recommended to use permanent materials when the suction pipe alone exceeds 9 m (30 ft) in length. A combination of materials may also be used, so that bamboo is only used as pipe and/or filter below groundwater level and is thus shielded from oxygen.

Performance

Output from the treadle pump depends on a variety of factors, including the height of the lift, the diameter of the cylinders, variations in internal friction, occasional air-leaks in the installation, "hard" filters, skills and care of the installation team, and the weight and agility of the operator. Several estimates are available of discharge rates with the treadle pump⁶. These are not always directly comparable, however, because some were made in a laboratory and others under field conditions. Only one test considers all the various cylinder diameters and their work-ranges.

RDRS findings

Recent tests by RDRS show that operating within the possible lift range of 1-2 ft to 29-30 ft, a range of four or five cylinder diameters should be used in order to maintain comfort and output at their best⁶. The results from these experiments may be found in Appendix 1.

Table 1.1 shows the sustainable output (discharge) from each suction depth for different cylinder sizes. Sustainable output is that whereby two or three medium weight operators can pump in shifts all day long. Using heavier operators and increasing the speed of pumping will increase output and make larger cylinders useful at higher suction levels.

The table shows that an output of 1 litre/second is maintained up to 29-30 ft (9 m). But output falls from 66 GPM at 2-6 ft lift to 13 GPM at 23-29 ft lift. For each step down in cylinder diameter there is a distinct fall in sustainable discharge. These results highlight the logical consequence of using foot-operated pumps and twin-cylinders: relatively high output can be sustained to higher lifts than usual for manual pumps.

The table indicates the optimum range for each pump. It suggests that 3½ inch cylinders give the highest output at suction depths of 14-24 ft (5-7 m). Discharge in this range averaged 27 GPM (2 l/s). To maintain this level of performance at greater suction depths, treadle pumps can

TABLE 1.1: DISCHARGE RATES BY SUCTION DEPTH AND CYLINDER SIZE						
PUMP SIZE	UNIT	CYLINDER DIAMETER IN INCHES AND MM				
		3"	3 $\frac{1}{2}$ "	4 $\frac{3}{4}$ "	6"	7"
		76 mm	89 mm	120mm	152 mm	178 mm
SUCTION RANGE						
	ft.	23-29	14-24	8-18	6-8	2-6
SUSTAINABLE						
DISCHARGE	GPM	13	27	40	53	66
	l/s	1	2	3	4	5
	l/hour	3600	7200	10,800	14,400	18,000
	cusec	0.036	0.070	0.106	0.191	0.177

Source: RDRS test results. See Appendix 1, Table A.1

be "tailored" by fitting them with larger cylinders. Many observers have failed to recognise the importance of using large cylinders at low heads. Further information on matching suction depth and cylinder diameters is given in Appendix 1.

Other findings

We can compare these discharge rates with those obtained by an independent study commissioned by the World Bank⁷. The "comfortable" discharge rate was 0.83 litres/second (11 GPM) at a suction depth of 3.5 m. This is about half the RDRS finding. At this rate, the discharge was about 18,000 litres/day for an adult male operator and 15,000 litres/day for a female or minor operator⁸. Discharge rates in practice may be higher if, as often happens, the treadle pump is operated by two people at the same time.

A comparison with other manual pumps (the rower pump, and the No. 6 handpump) showed that the treadle pump had the highest discharge rate up to heads of 3.5 m⁹. Three design features contributed to this high output: the use of full body weight, and leg muscles; twin cylinders and alternating strokes, which provide a continuous flow; and the water outlet at ground level, which saves a pumping head of about 1 ft (0.3 m).

Ergonomics

Ease of operation can be measured in terms of the physical energy required to pump a given volume of water. Several studies have been made to compare the ergonomics of different manual irrigation

pumps¹⁰. The most comprehensive of these was commissioned by the World Bank to compare the energy requirements of the treadle pump with those of the rower, No. 6 and Tara pump¹¹. Here, we summarise its findings about the treadle pump.

The study made field tests of 30 treadle pumps in three different locations in Bangladesh. At each site, engineers measured the power required to operate the treadle pump for each operator and expressed this in watts over the Basic Metabolic Rate (BMR). The average BMR (62 watts) is the barest minimum energy demand, equivalent to lying in bed doing nothing. The power to raise water at different lifts can be expressed as the number of watts over and above this basic rate. The results are shown in Figure 2.

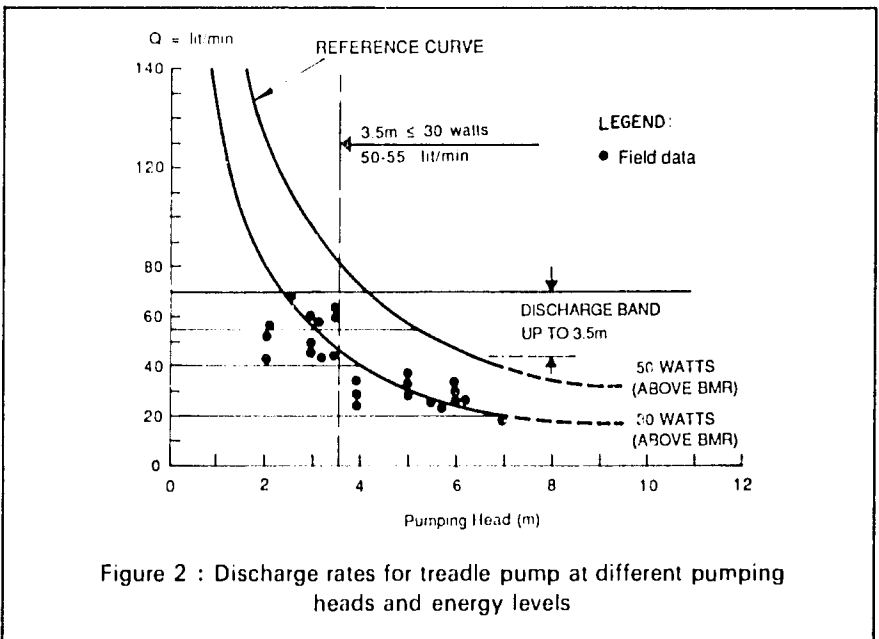

Figure 2 shows the watts over BMR required by different operators together with the level of pumping head and the discharge rate. The "reference curve" in the diagram shows the average output from any type of manual pump at 30 and 50 watts over BMR assuming an efficiency of 65%. It can be seen that, under field conditions, the treadle pump delivered about 50-55 litres/minute at an input of 30 watts over BMR at a pumping head of 3 m. Beyond 3.5 m the discharge rate gradually fell and at 5 m it dropped to about 28 litres/minute at 30 watts over BMR.

"Comfortable" operation was defined as energy expenditure between 30-50 watts above BMR. Pumping continuously for 20 minutes, then resting for 10 minutes, a healthy adult male could operate the treadle pump comfortably for 5-6 hours per day. The study concluded that, for lifts of up to 3.5 m, the treadle pump required less effort than any other manual irrigation pump¹²

1.2 SIMPLICITY OF MANUFACTURE

Simplicity was the second design criterion of the treadle pump. It was intended to be simple enough to be made locally and maintained by farmers or a village pump-contractor, using standard materials and spare parts available in local shops.

Treadle pumps can be made from a variety of materials, including steel, cast iron, plastic, glass, and concrete. In Bangladesh, the pump is made from a limited range of materials all of which are locally available. To make a treadle pump, all that is needed is 10 or 12 mm steel rods, 14 gauge (1.99 mm) sheet steel, bamboo, and rubber or leather. Workshop equipment is equally simple. Hammers, chisels, a vice, a grinder, and drilling, cutting, and bending devices are the main tools. To add speed and precision, some workshops also use a lathe, and rolling and cutting machines.

A visit to the North Bengal Agricultural Workshop (NBAW) in Lalmonirhat, the oldest and largest manufacturer of treadle pumps in Bangladesh, illustrates the simplicity of the manufacturing process. The workshop employs 23 contract artisans and 11 salaried staff. Three types of pumphead are made:

- 14 inch length, $3\frac{1}{2}$ inch diameter, with drinking spout;
- 12 inch length, $2\frac{1}{2}$ inch diameter, without drinking spout; and
- 12 inch length, $4\frac{3}{4}$ inch diameter, without drinking spout.

Demand is greatest for the 14 inch, $3\frac{1}{2}$ inch diameter cylinder with drinking spout attached.

There are five steps to the manufacturing process:

- Sheet metal is cut for cylinders and plunger discs. The discs are drilled for the plunger rods, then smoothed on a lathe.
- The cylinders are welded together, and the junction box and drinking spout are welded on. The cylinders are coated with bitumen to prevent rust.
- The check valves are added to the cylinders.
- Blacksmiths make the plungers from iron rods.
- The metal discs are welded to the plunger rods.

All the components are available in Bangladesh. Sheet metal for the cylinders is bought in Dhaka, while iron rods for the plungers are purchased in Rangpur. Hard *babla* wood (*Acacia nilotica*) for the pulley wheel is brought from Kushtia. Similarly, all the workshop's tools are locally made, except for the drilling machine for the plunger discs, the welders, and the lathe.

1. 3 COSTS

Finally, the third design criterion was minimum cost. The total cost and installation of the pump was not to much exceed the value of one bag of paddy. Sale against credit was ruled out. In this section, we estimate the cost of a treadle pump with a bamboo tubewell. Prices vary, and we have used prices in the "high" range (Table 1.2). The estimates are based on a survey of treadle pumps in northern Bangladesh in 1988.

No. Item	No/qty	Price (Taka)	
		High range	Low range
1. 3½ inch pumphead and all metal parts	1	290	250
2. Bamboo for pipe, filter, and frame	3	120	105
3. Netting for filter	3 yds	40	20
4. Pitch	0.5 kg	10	2
5. GI wire (No. 14)	2 <i>chataks</i>	5	5
6. Polythene	1 sheet	2	2
7. Installation charge for 30-40 foot pipe	1	150	100
Total		631	495

Pumphead

The most popular pumphead in the survey area was a 3½ inch diameter pumphead with an attached drinking spout which had a retail price of Taka 290. Even cheaper pumpheads exist, but sometimes of poorer quality.

Bamboo

Usually, three 6 m (20 ft) sections of bamboo are needed for the superstructure and tubewell. One bamboo is required for the pipe, a second for the filter, and a third for the superstructure. If the depth of the bore is over 12 m (40 ft), four bamboo sections are required.

Different varieties of bamboo are used for each section. The botanical classification of bamboos is presently very confusing. Here, we have adopted the classification proposed by Boa and Rahman¹³. *Borobash* (*Bambusa vulgaris*) has a small diameter and is suitable for the treads and frame. *Joitha* (*Bambusa balcooa*) and *Makla* (*Bambusa tulda*) have larger diameters and are suitable for the pipe and filters. Matured, three-year old bamboo is preferable because it lasts longer. The market price of one 6 m (20 ft) section of bamboo in northern Bangladesh in March 1988 was Taka 40. Thus, the cost of three sections required for the treadle pump was approximately Taka 120.

Other costs

Other expenses include three yards of plastic netting for the filter (Taka 40); half a kilogram of pitch for sealing the pipe and pumphead (Taka 10); 2 *chataks* of GI wire (Taka 5); two *chataks* of thin, nylon thread for the filter (Taka 14); and polythene papers to join the filter and pipe (Taka 2).

Installation

The cost of installation is minimised through the manual sludge-boring method, which does away with the need for expensive drilling (see Appendix 2). The sludge-boring technique is ideally suited to the deep sand and silt which underlie most of Bangladesh. It enables a three-man team equipped only with a bamboo scaffold, a chain, and enough 40 mm galvanised iron pipe for the planned well-depth to sink a hole to a depth of 50 m or so within a few hours. The three man team of mechanics is trained by RDRS.

The cost of installation varies according to the depth of the well, the type of soil, and whether or not the soil contains large stones. A 6 m (20 ft) well costs between Taka 70-100 to install. A 9-12 m (30-40 ft) well costs between Taka 120-150 to install. The average depth of well was between 9-12 m. Adding the cost of pumphead, bamboo, other items, and installation, the capital cost of a treadle pump in March

1988 was Taka 631, or about \$ 20 at financial prices (Table 1.2). Prices in 1990 were similar. It is the cheapest manual irrigation pump currently available in Bangladesh.

CONCLUSION

The development of the treadle pump illustrates several important aspects in the design of appropriate technology for small farmers.

RDRS started with a clear concept of the type of pump farmers needed. It had to have an output sufficient to irrigate at least 0.5 ha of wheat; the total cost of purchase and installation was not to be more than the price of one bag of paddy; and the pump was to be simple enough to make and repair locally. The design followed logically from these three criteria. High output combined with ease of operation led to the concept of a foot-operated pump. Minimising costs led to the use of a bamboo tubewell and frame. Simplicity of manufacture meant the use of locally available materials such as steel rods and sheet steel.

The result is a pump which meets the needs of small farmers. Output up to lifts of 3.5 m is higher than with any other manual irrigation pump. A conservative estimate suggests that an adult male operator can comfortably pump 18,000 litres per day. This is sufficient to irrigate about one acre of wheat or vegetables and one-third of an acre of rice. The pump is also cheaper than its rivals. In March 1988 the cost of a treadle pump with a bamboo tubewell was Taka 631 or about \$ 20.

REFERENCES

1. RDRS, Annual Report, 1980.
2. M. A. Jabbar, *Commercialisation of Agricultural Equipment Generated by R & D System in Bangladesh*. World Employment Working Paper. ILO, Geneva. September, 1985 p. 17.
3. G. Barnes, "The Twin Treadle Pump: Manual Irrigation in Bangladesh". In IRRI, *Small Farm Equipment for Developing Countries*, IRRI, Los Banos, Philippines, 1986, p. 184.
4. This description is based on R. E. Stickney, V. Piamonte, Q. de Sagun, and I. Ventura, "Human Powered Pump for Low Lift Irrigation". Paper presented at the 1985 Summer Meeting of the American Society of Agricultural Engineers, Michigan State University, East Lansing, June 23-26, 1985.

5. M. Taher Ali, D. K. Das, S. M. Nazrul Islam, and A. K. Mesbah Uddin, "Treadle pump: assessment of engineering aspects", *Journal of Institute of Engineers, Bangladesh*, Vol. 15 No. 1 (June, 1987), pp. 23-30; BRRI, Annual report on determination and identification of ergonomic characteristics of manually operated pumps and pumping devices widely used by the farmers. Agricultural Engineering Division, BRRI, 1988, Mimeo, 21 pp. and 1989, Mimeo, 29 pp.; Engineering and Planning Consultants, Testing of Handpumps under IDA-assisted HTW Project (Credit 1140-BD). Draft Final Report, August, 1987, Mimeo, 114 pp.
6. G. Barnes and M. I. Khan, "Update on Twin Treadle Pumps". RDRS, April/May, 1990, Mimeo, 24 pp.
7. Engineering and Planning Consultants, Testing of Handpumps under IDA-assisted HTW Project (Credit 1140-BD). Draft Final Report. August, 1987.
8. Ibid, p. 110
9. Ibid, pp. 110-111.
10. See references in footnote 5, above.
11. Engineering and Planning Consultants, Testing of Handpumps under IDA-assisted HTW Project (Credit 1140-BD). Draft Final Report. August, 1987.
12. Ibid, p. 113.
13. E. R. Boa and M. R. Rahman, *Bamboo Blight and the Bamboos of Bangladesh*. Forest Pathology Series No. 1. Forest Research Institute, Chittagong, July, 1987.

2

MARKETING

To succeed, new technology must not only be appropriate but must also be effectively marketed. The dissemination of any technology involves the following steps: developing a prototype; field testing a number of prototypes; developing a design and a system for mass production; and marketing. Unfortunately, many organisations working to develop appropriate technology are capable of the first three steps, but have no idea how (and sometimes no desire) to carry out step four. Also there may be an aversion on the part of some NGOs to work with, and use foreign aid to help, private businessmen.

A distinguishing feature of the spread of the treadle pump, however, has been the role of private businessmen both in production and marketing. RDRS financed and set up several small private workshops to produce the treadle pump. Later, IDE recruited and trained a network of private dealers which created hundreds of marketing outlets throughout the country. Private business has thus proved to be the vital final link in the chain of technology dissemination.

This chapter begins with a brief description of production outlets. The next two sections describe sales and marketing. Finally, we try to assess the potential demand for treadle pumps in Bangladesh.

2.1 PRODUCTION

Treadle pumps are made in small privately owned workshops. The first treadle pumps were manufactured by the RDRS Agricultural Workshop in Rangpur in 1980. The capacity of the workshop was only 20 pumpheads per day¹. To boost output, RDRS helped finance a private workshop in Lalmonirhat in 1981. Two other workshops were set up in 1982 in Dinajpur and Kushtia. Production capacity in these three workshops was estimated at 3,000 pumpheads per month². Finally, a

fourth workshop at Ulipur began production in late 1984. In total, these four workshops, plus the RDRS Appropriate Technology Workshop in Rangpur, had a combined capacity of 3,500 pumpheads per month or 40,000 pumpheads per year³. Today, pumpheads are made by more than twenty privately owned workshops located in the following districts: Dhaka, Lalmonirhat, Kurigram, Dinajpur, Natore, Tangail, Sherpur, Gazipur, Narsingdi, Narayanganj, Gopalganj, and Feni. The total production capacity of these workshops is still below the market demand (currently about 65,000 pumps per annum).

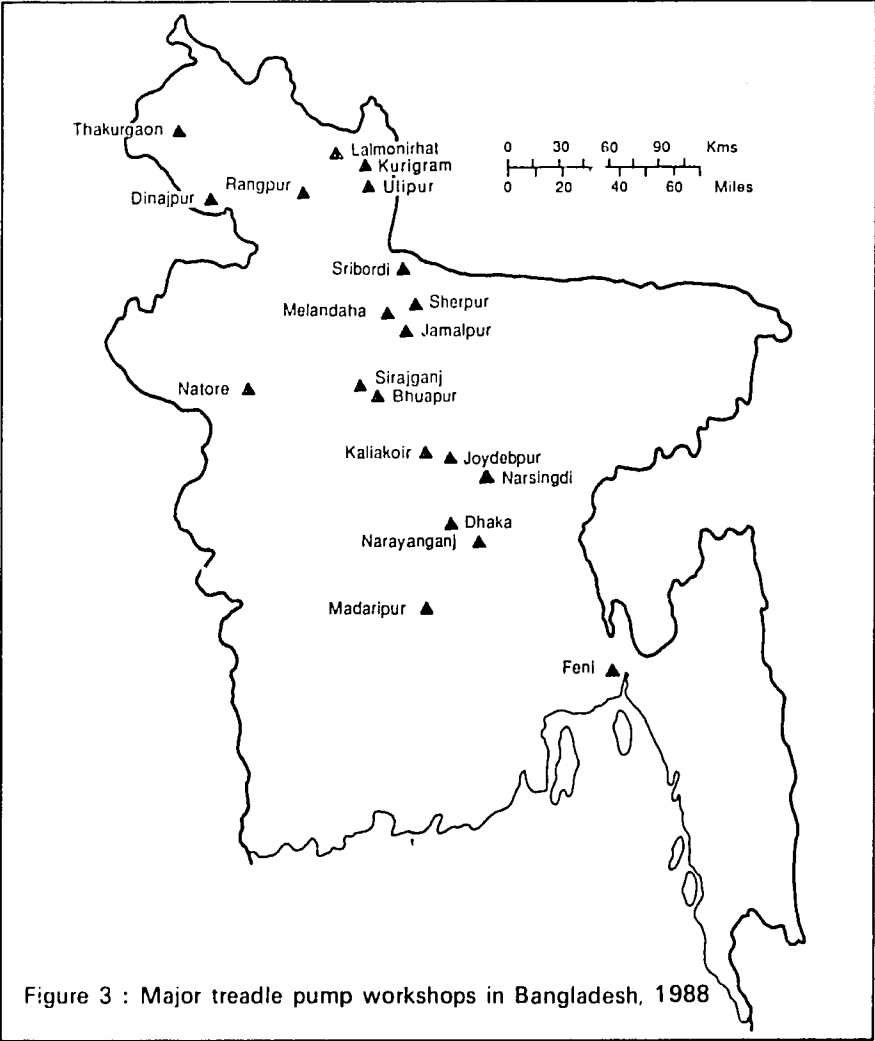
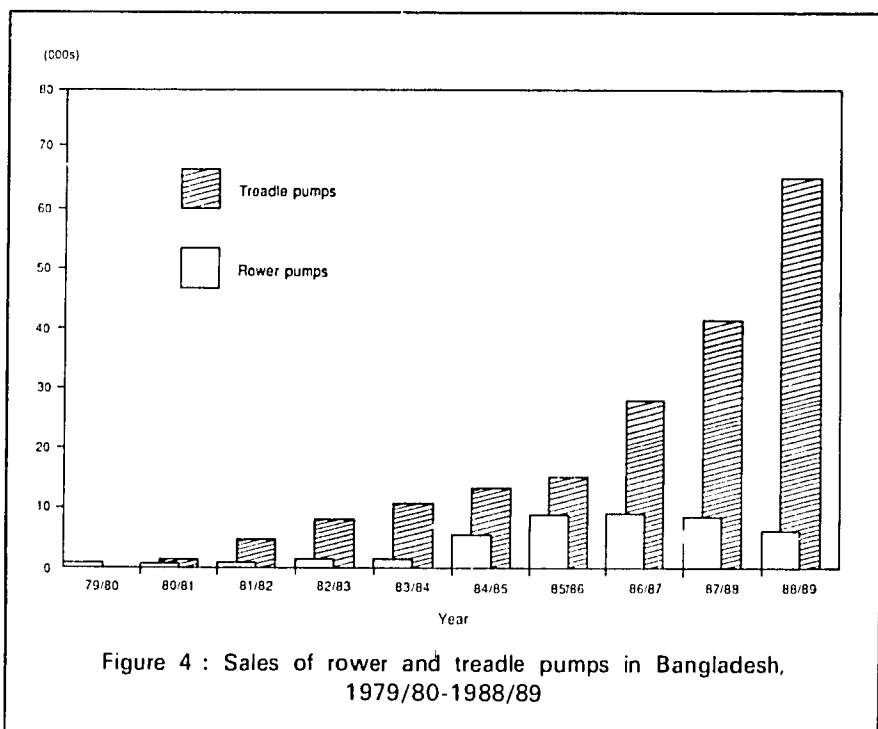

Figure 3 : Major treadle pump workshops in Bangladesh, 1988

Figure 3 shows the distribution of treadle pump workshops in 1988. Clearly, the potential for irrigation by treadle pump is not confined to Rangpur and Dinajpur districts where it was first introduced but extends over large tracts of the country.

2.2 SALES

Accurate figures of the sales of manual irrigation pumps in Bangladesh are not available. It is possible to reach a rough estimate



by adding the sales figures for different programmes and including an estimate for sales by private workshops. Figure 4 shows the trend in sales of rower and treadle pumps between 1979/80-1988/89. Sales of treadle pumps rose from a mere 1,800 in 1980/81 to 64,000 in 1988/89. Cumulative sales over the period were estimated at 186,000.

These figures do not include sales of No. 6 HTWs which are sold both through the private sector and through government programmes. Most No. 6 pumps sold as MOSTIs are used for drinking water rather than for irrigation. A survey of MOSTIs sold between 1975-79, for

example, showed that only 42% were used for irrigation⁴. A more recent study of MOSTI sales estimated that the proportion used for irrigation of field crops and kitchen gardens was 35%⁵. The World Bank suggests that in 1984 there were 1 million No. 6 HTWs in Bangladesh, of which about 400,000 were used for irrigation⁶.

2.3 MARKETING

Although treadle pump sales had reached 7,000 a year by 1984, sales had been limited to Rangpur and Dinajpur districts in northern Bangladesh, with some pumps reaching Jamalpur and Kushtia. The sales channel was direct from firm to user. Extending sales to other areas of Bangladesh was difficult because of the small size of treadle pump manufacturers, and the absence of a nationwide sales network.

Enter International Development Enterprises (IDE), an NGO established to promote small business enterprise. In 1984 IDE began a project in Bangladesh called Marketing Appropriate Technology. Its objective was to identify appropriate technologies to raise productivity and income on small farms, and to market these on a large scale throughout Bangladesh. IDE identified the treadle and rower pumps as suitable for this programme.

IDE's strategy for marketing manual irrigation equipment had six main components:

Diversifying the production base : Initially, production of the pump, PVC pipe, and filter was carried out by the NBAW and MAWTS, but IDE worked with other manufacturers to develop their own production capacity as demand grew. This served to diversify production and create some competition in order to maintain a low price and good quality.

Quality control : IDE acted as a wholesaler, purchasing materials from the manufacturer, doing quality control inspections, marking the material with a brand name, and selling the materials to a network of rural dealers. Creating brand name identification and faith in the quality of the product was a key to gaining the farmers' confidence in the product.

Advertising : IDE created a range of advertising and promotional materials (posters, calendars, leaflets, cinema slides, T-shirts, etc.)

which were put at the disposal of IDE staff and pump dealers as sales aids. Other promotional techniques such as farmers' rallies and microphone broadcasting were also developed.

Training : IDE hired field staff to be posted in the sales areas. They were trained to be technically competent in pump installation and maintenance, as well as in marketing and sales techniques. It was the task of these staff to identify and cultivate a relationship with rural traders who were interested in selling manual pumps, promote the use of such pumps among local farmers, train installation teams, and oversee installation of the pump to ensure that the work was done properly .

Creating a dealer network : IDE appointed a network of rural traders to act as pump dealers. The dealers bought the pump components at a wholesale price and sold them to farmers at a retail price that was 15% higher than the wholesale price. The dealers were trained by the field staff in manual pump technology, and given additional sales training and motivation in twice-yearly dealers' conferences. In 1989, IDE had a network of 134 dealers active in 76 upazilas.

Coordination : IDE helped coordinate the activities of other organisations working to disseminate manual irrigation pumps by setting up the Manual Pump Group. This group was composed of five organisations, and acted as a forum for discussing common issues, joint production of promotional materials, and setting up a credit programme.

Between 1984-86, IDE concentrated most of its efforts on the marketing of rower pumps. In 1986, however, IDE field staff in Jamalpur and Sherpur districts in northern Bangladesh reported competition from treadle pumps sold by the NBAW in Lalmonirhat. It was the opinion of the field staff that the treadle pump was more suitable than the rower for this area. The result was an agreement whereby IDE marketed NBAW pumps in this region.

The next two years saw an explosion of treadle pump sales in these two districts. A number of factors were responsible:

- the treadle pumps produced by the NBAW quickly earned a name for excellent quality;
- by using private traders IDE could cover a large area with minimal staff. At the peak of activity in this area, IDE had four sales staff controlling a network of more than 30 dealers;
- the hydrology of the area (a high water table and a shallow aquifer) made it possible to install manual tubewells at minimal cost;
- the area was remote and small farmers had no alternative means of irrigation.

By 1988, booming sales had stimulated competition from private producers. With no barriers to entry, over 20 independent manufacturers sprang up around the country. Quality suffered, but the proliferation of treadle pump workshops ultimately lowered prices. By this time, IDE had opened up new markets for treadle pumps in Kushtia, Tangail, Kishoreganj, Narsingdi, and Brahmanbaria, and later in Natore, Serajganj, Pabna, and Bogra. As the market was now more competitive, IDE could no longer control the conditions of dissemination as it had done in Jamalpur and Sherpur. No sooner had IDE moved into a new area than the market was flooded with poor quality pumps. Since farmers were unfamiliar with the technology, their first impressions were not always positive. Nevertheless, sales continued to rise steadily.

1989 brought a change of strategy. IDE's role was to promote small business, not compete with it. IDE began to pull out of wholesaling and switched over to giving marketing and technical assistance to those producers who were interested in opening up new areas or taking over from IDE in existing markets. A strategy was developed whereby IDE took on partner producers in each working area. The objective was to help private producers improve quality and business practices and develop marketing networks using private dealers, just as IDE itself had done. Ultimately, producers will be able to stand on their own feet.

2.4 THE SIZE OF THE MARKET

The market for manual irrigation in Bangladesh is limited by both economic and hydrological factors. The main economic constraints on

demand are the cost of labour for pumping and competition in the water market from motorised pumps. At present, treadle pumps are only profitable when the opportunity cost of the farmer's family labour is less than the current market wage. An increase in the price of labour would reduce the benefits from manual irrigation significantly. Given rapid population growth and widespread underemployment in the dry winter season, however, it seems likely that manual irrigation will remain attractive to small farmers for some time to come.

Competition from motorised pumps, especially STWs, will also reduce the demand for treadle pumps. Given a choice, farmers would prefer to buy water from the owners of STWs rather than irrigate themselves by manual methods. An efficient water market, where farmers were assured of timely and adequate supplies, would make it unnecessary for small farmers to buy their own irrigation pumps. There is evidence that this has already happened in some areas of Jamalpur and Sherpur districts. The spread of STWs in these areas has reduced the demand for treadle pumps. Where water markets are not efficient, however, farmers may still prefer to keep manual pumps in reserve to ensure that they can irrigate on time.

Motorised pumps also compete with manual pumps for groundwater since they all generally extract water from a common aquifer. Because motorised pumps have deeper tubewells, manual pumps sited within their cone of influence can run dry. The cone of influence for a STW is about 8 ha. In 1988, the GOB prepared a Ground Water Control Ordinance to regulate the siting of motorised pumps. This was revoked in 1989. Currently, there are no controls on the siting of DTWs and STWs. Thus, the rapid increase in sales of STWs may ultimately deprive many treadle pumps of their water supply.

Hydrologically, the main constraint on the demand for manual irrigation pumps is the depth to the groundwater. Research by RDRS shows (Table 1.1) that treadle pumps can operate at suction depths of up to 9 m (29-30 ft). Output at this depth is low, however. Normally, a treadle pump with a bamboo tubewell produces an acceptable output where the water table in the dry season lies within 6 m (20 ft) of the ground surface. Bamboo tubewells become uneconomic at greater suction depths. Treadle pumps with PVC tubewells can operate at

greater depths, however. PVC tubewells cost more to buy, but they last longer than bamboo wells.

A second limitation is posed by the use of a bamboo tubewell, which may leak. The joints are sealed with bitumen and how securely they hold depends on the skill of the mechanic. In fact, leaks from

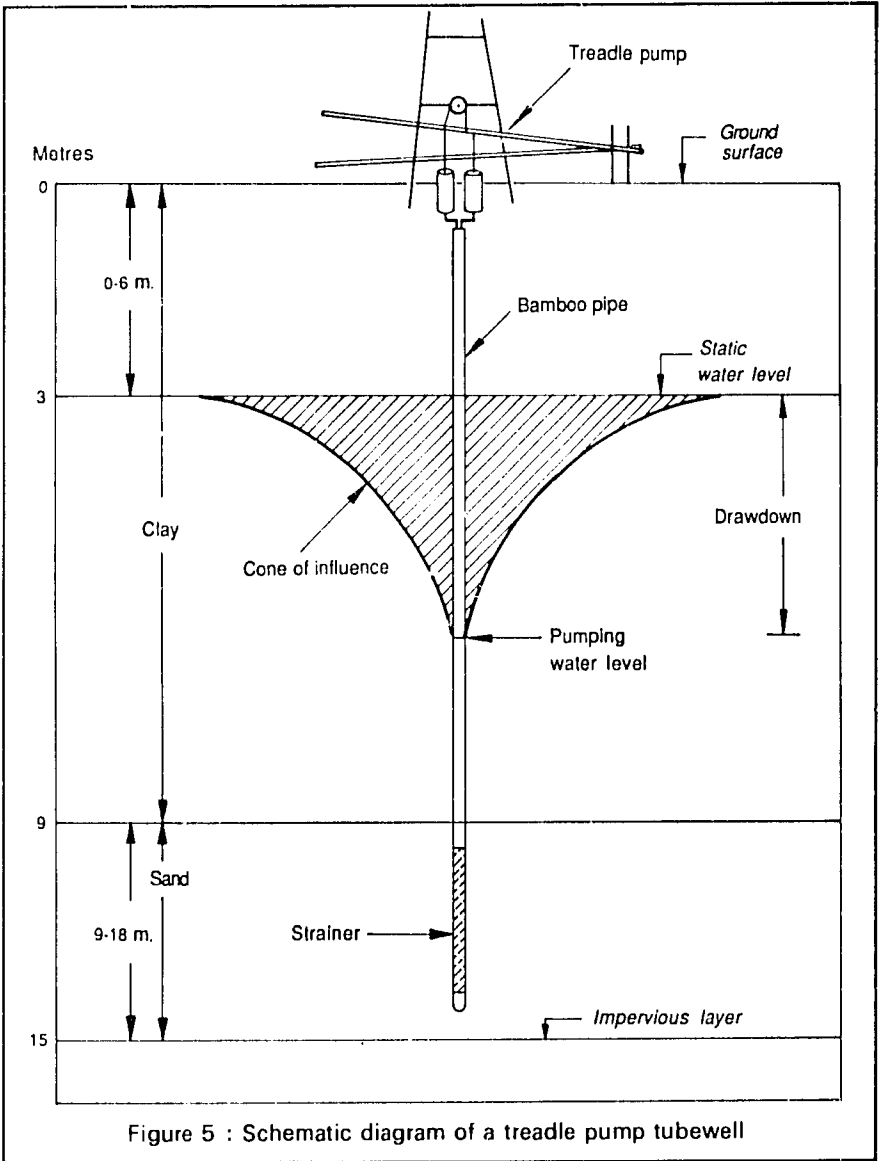

Figure 5 : Schematic diagram of a treadle pump tubewell

bamboo tubewells are rare. To ensure that the joint is always submerged and that leaks are of minor significance, however, treadle pumps with bamboo tubewells are only practical where the aquifer can be found within 15 m (50 ft)⁷. The cost of installation and the suction pipe also rises with deeper aquifers. RDRS does not recommend installation of bamboo tubewells below depths of 18 m (60 ft).

Figure 5 illustrates these hydrological constraints for a typical treadle pump with a bamboo tubewell. The water table lies within 3 m (10 ft) although depths of up to 6 m (20 ft) are possible. The aquifer lies within 9 m (30 ft) of the ground surface.

Fortunately, these hydrological constraints do not pose a serious problem in Bangladesh. Figure 6 shows that over most of the country the water table in the dry season lies close to the ground surface. Groundwater levels are highest from August through October during the monsoon. They start to recede in October and November and generally reach their lowest level in April and May. In normal years, about 90 % of total groundwater reserves lie within 7 m of the surface even in the dry season. Allowing for current abstractions, it is estimated that about 11,600 Mm³ is available for manual irrigation purposes. In theory, this resource could support about 5.9 million manual irrigation pumps. In practice, however, the expansion of mechanical irrigation will reduce the groundwater available for manual pumps, which draw their water from the same aquifer. Assuming that the targets in the Third Five-Year Plan period are met, by 1990 about 62 % of groundwater resources will be exploited. This will leave about 1,350 Mm³ available for manual irrigation, sufficient for 800,000 additional units above those included in the Third Five-Year Plan⁸.

Area suitable for treadle pumps

It is difficult to give a precise figure for the area suitable for irrigation by treadle pumps. The map in Figure 6 shows that treadle pumps have sold widely in areas where the maximum depth to groundwater table in the dry season averaged 3-5 m : Rangpur, Dinajpur, Mymensingh, and Kushtia. But maps of potential irrigable area based on average depths of water table during the dry season are highly generalised. Information on the depth of water tables is based on averages covering large areas and does not take account of variations which take place even from one union (group of villages) to the next. Besides, water table and

depth of the sand layer are not the only factors to be considered; agronomic practices are also important. It would be fair to say that there are areas suitable for treadle pump irrigation in almost every upazila in Bangladesh, excluding the Chittagong Hill Tracts and the Barind.

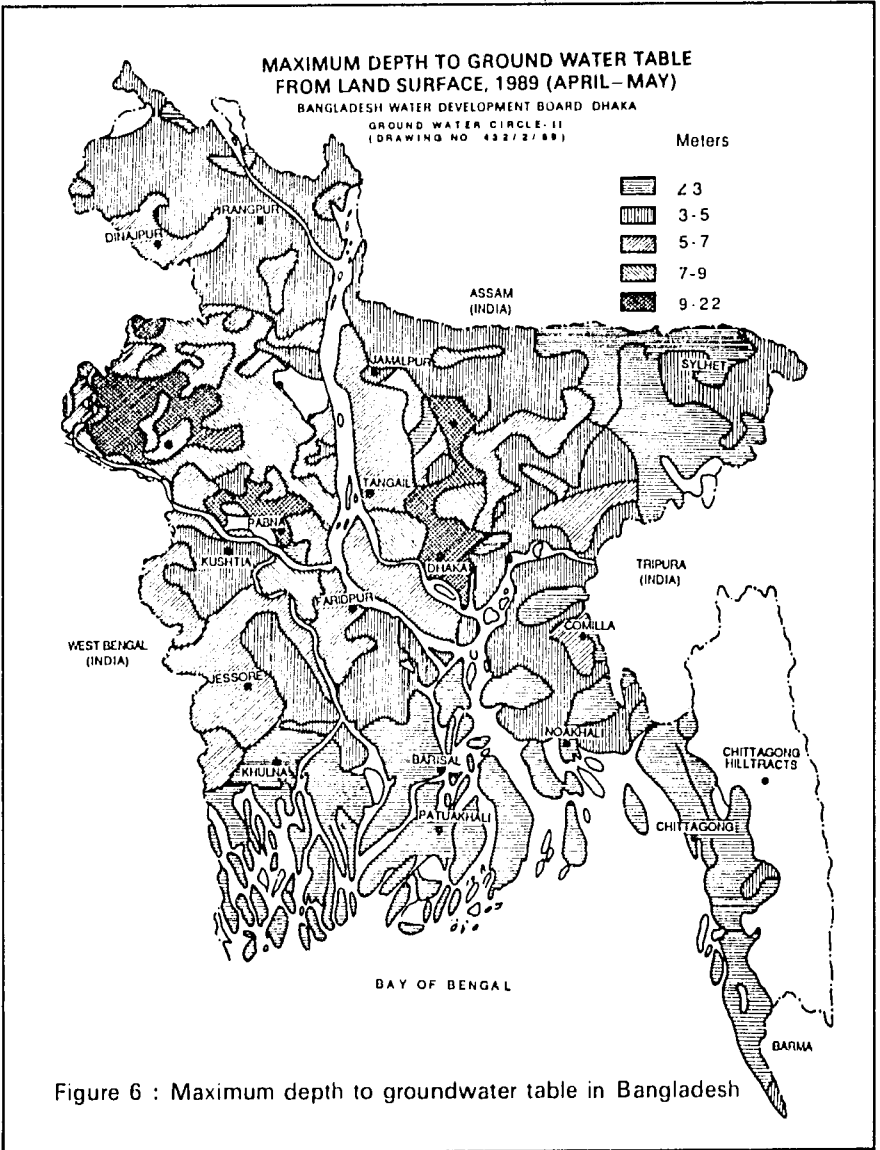

CONCLUSION

A key factor in the spread of the treadle pump has been good marketing. Treadle pumps are produced by small, private workshops for which the main sales channel is direct from firm to user. The creation of a national sales network is beyond the capacity of such small firms. IDE, which acted as a wholesaler for private manufacturers and created a network of private dealers, has assisted a faster and wider spread of the treadle pump. The use of private traders to disseminate the pump has encouraged rapid growth in sales. Currently, sales are running at about 65,000 manual pumps a year. Future demand for manual pumps is difficult to estimate but will clearly depend on the price of agricultural labour, and technical limitations which restrict the use of manual, suction-lift pumps to areas where the water table in the dry season lies within about 6 m of the ground surface. Competition from motorised tubewells also restricts demand since these draw their water from the same aquifer. A conservative estimate by the World Bank suggests that, assuming the targets set in the Third Five-Year Plan are met, there is sufficient groundwater for about 800,000 additional manual irrigation pumps.

REFERENCES

1. RDRS, Annual Report, 1980.
2. RDRS, Annual Report, 1982.
3. RDRS, Annual Report, 1985.
4. M. A. Miyan, M. Hassan, and M. Hassan, Manually Operated Shallow Tubewells for Irrigation, Institute of Business Administration, University of Dhaka, March, 1980, p. 75.
5. M. Ahmad and I. Ahmad, Socio-economic survey on the beneficiaries of the IDA assisted hand tubewells project, Consortium of University Teachers for Evaluation, Training and Research, University of Dhaka, March, 1987, p. 3-27.
6. FAO/World Bank, Bangladesh Hand Tubewells II Project Preparation Mission, Report of the FAO/World Bank Cooperative Programme Investment Centre, 27 June, 1985, p. 4.
7. E. Baumann and R. Fuller, Manual Irrigation in Bangladesh, Swiss Development Corporation, Dhaka, March 1984, p. 10.
8. FAO/World Bank, Ibid 1985, p. 6.

3

ADOPTION AND MAINTENANCE

Despite the popularity of the treadle pump there has been no study of its socio-economic impact. In this chapter we analyse adoption and maintenance. The treadle pump was designed to provide irrigation for small farmers and to be easy to maintain and repair. How far have these objectives been met in practice?

Our data are drawn from a sample survey of 189 treadle pumps conducted independently by the Bangladesh Rice Research Institute (BRRI)¹. Two upazilas, Pirganj in Thakurgaon district and Aditmari in Lalmonirhat district, were purposively selected for survey (Figure 7). We chose these upazilas because they represented different agro-ecological regions and contrasting land types². The real significance of the Pirganj-Aditmari comparison is that in Pirganj the treadle pump was used to irrigate winter rice whereas in Aditmari it was used to irrigate high-value *rabi* crops like tobacco, wheat, and vegetables. Both sites lay within the RDRS project area and had adopted large numbers of treadle pumps.

Within each upazila we purposively selected four villages where farmers had adopted treadle pumps and which represented a range of land types. A simple random sample of 160 pump adopters was selected for survey. Data were collected by village youths who were residents of the survey villages. The survey was conducted during the winter cropping season (November 1987-March 1988) which is the peak period for treadle pump irrigation.

The chapter is divided into three parts. The first section looks at pump adopters and examines the source of funds for buying the

treadle pump. In the second section, we discuss maintenance, the frequency of repairs, the mobility of treadle pumps, and theft. We then summarise our conclusions.

3.1 ADOPTION

RDRS defined the target group for whom the treadle pump was designed as "farmers (landowners or sharecroppers) owning or farming less than 2 acres (0.8 ha) of land, and with little other significant

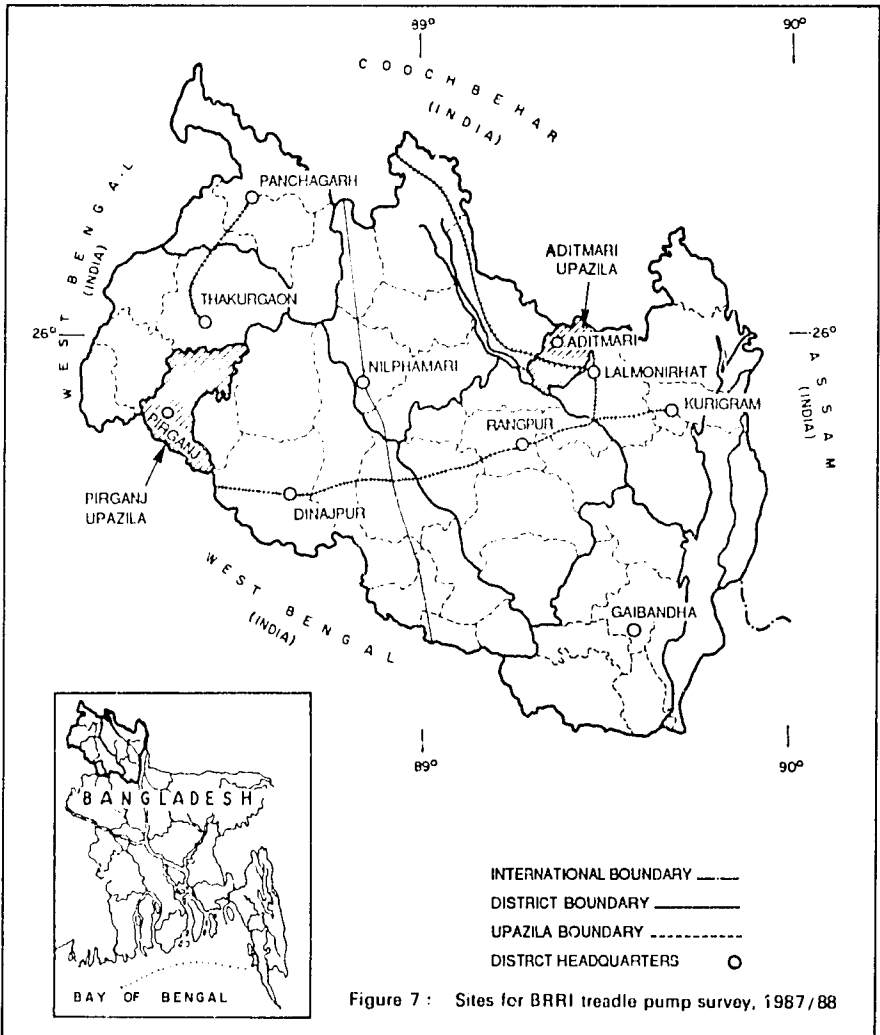

income or support"³ . To test the hypothesis that the treadle pump had reached the target group, we compared adoption of the treadle pump across different farm sizes. Four farm-size categories were selected.

Small farmers

Table 3.1 shows the distribution of pump ownership by farm size group for both the study areas. The table shows that 129 farms or 84 % of pump adopters farmed less than 1 ha. Thus, a very high proportion of treadle pumps have reached the target group. The proportion of small farmers adopting the pump was higher in Pirganj upzila. In this study area, 56 farms or over 75 % of adopters farmed less than 0.25 ha. In Aditmari, by contrast, adoption was more evenly spread over different farm size groups, though most adopters were still small farmers. Table 3.1 shows that 57 farms, or 71 % of adopters were found on farms of less than 1 ha.

FARM SIZE	PIRGANJ	ADITMARI	TOTAL
(ha)			
< 0.25	56	11	67
0.25-0.49	16	20	36
0.50-0.99	2	26	26
1.0 >	-	23	23
Total	74	80	154

It is instructive to compare these results with previous research. Average farm size in the treadle pump survey was 1.53 acres (0.64 ha). By comparison, the 1986 rower pump survey found that 64 % of adopters owned less than 2.5 acres. Average farm size was 2.48 acres⁴. The 1987 rower pump survey found that 67 % of adopters had farms below 2 acres. Average farm size was 1.63 acres⁵. Our results, therefore, correspond closely with those of the 1987 rower pump survey.

Treadle pumps seem to have been more successful than No.6 HTWs in reaching the small farmer. A study of No. 6 handpump sales

between 1975-79 showed that the average farm size of adopters was 3.81 acres⁶. Similarly, the IDA HTW Project was targeted at farmers with less than 1.5 acres, but only 32 % of adopters came from this size group⁷. This probably reflects the higher cost of the No. 6 pump.

Sharecroppers

The RDRS target group includes sharecroppers or those who rent in land. Out of 155 farms in the sample, 60 or 39 % were owner-tenants, renting in some land on a sharecropping basis. Seven adopters were pure tenants who owned no land apart from homestead plots. One adopter was a landlord who did not cultivate his own land. Fifty-six percent of adopters were owner-operators. Thus, the treadle pump had been adopted by sharecroppers as well as owner-operators. This is not surprising since farmers who sharecrop-in land in Bangladesh are typically small farmers with surplus family labour and too little land.

Renting out of treadle pumps

Nine farms in the sample (6 %) rented out their treadle pumps to sharecroppers. Significantly, all these pumps were located in Pirganj where they were used to irrigate winter rice (*Boro*) which is highly labour intensive. Six of these nine farms had only one adult male in the household, suggesting that labour shortage may have been the primary reason for renting out pumps. The normal practice was for the owner to receive half the crop.

Critics of manual irrigation have argued that the practice of renting out pumps exploits the poor and benefits better off farmers⁸. A study of 54 No. 6 HTWs in Jamalpur district, where nearly half the owners rented out their pumps, showed that sharecroppers who grew *Boro* rice could not even recover their cash costs⁹. This practice may be widespread. A survey of No. 6 HTWs sold between 1975-79 showed that no fewer than 60 % of owners rented out their pumps to sharecroppers¹⁰.

The renting out of manual pumps reflects, not the inequitable nature of the technology but the unequal distribution of land. Land in Bangladesh is scarce and labour plentiful. Irrigation increases the value of land still more. In these circumstances, manual irrigation pumps are

profitable enough to rent them to others in exchange for labour. Conversely, labour is so cheap that those without access to land are willing to operate a treadle pump in exchange for less than half the crop. Renting out treadle pumps is, therefore, inevitable given the relative prices of land and labour in Bangladesh. Our survey suggests, however, that most treadle pumps are operated by the owners themselves using family labour.

Multiple ownership

A striking feature of pump adopters was that 27 farms (18 %) owned more than one treadle pump. Most of the farmers owning more than one pump owned two, but one farmer owned no fewer than five treadle pumps. Multiple ownership was concentrated among farms below 0.5 ha in size. Sixteen out the 27 farms owning more than one pump belonged to this farm size group. Multiple ownership of treadle pumps was more common in Pirganj than in Aditmari. Twenty-two farmers owned more than one pump in Pirganj compared to just four in Aditmari. Multiple ownership in Pirganj reflected the use of the treadle pump to irrigate *Boro* rice. Since rice required continuous irrigation over a period of two months, the average command area which could be irrigated by treadle pump was only one-third of an acre. Farmers wishing to irrigate a larger area needed to buy another pump.

Irrigation vs. drinking water

Unlike the No. 6 HTW, which was originally designed to provide clean drinking water, the treadle pump was designed specifically for irrigation. How far has this objective been met in practice?

TABLE 3.2: USE OF TREADLE PUMP FOR IRRIGATION AND DRINKING WATER, BY UPAZILA			
UPAZILA	USE OF TREADLE PUMP		
	IRRIGATION ONLY	IRRIGATION & DRINKING	TOTAL
PIRGANJ	99	5	104
ADITMARI	35	50	85
TOTAL	134	55	189

Chi-Square: 63.54 Significant at 0.001 level

Table 3.2 shows that all the treadle pumps in the sample were used for irrigation or for irrigation and drinking water (by contrast, more than half the No. 6 HTWs sold for irrigation are used exclusively for drinking water¹¹). The table shows, however, that many farmers used their treadle pumps for **both** irrigation and drinking water. This practice was more common in Aditmari. During our field visits, we noted that many farmers fitted up the pumphead in a corner of the homestead, and attached a short bamboo stick as a lever to raise drinking water. This adaptation closely resembled the RDRS hand-pump. In other cases, farmers made their own crude drinking spouts out of hammered tin cans.

Source of funds

Earlier, we noted that the high cost of irrigation equipment prevented small farmers from purchasing irrigation pumps. The cost of a treadle pump in 1988 was Taka 630. To determine whether this price was within the reach of the small farmer's own cash resources, we examined the source of funds for each treadle pump in the sample. Table 3.3 shows that of the 189 pumps for which data were available, 163 or 86 % were bought with the farmer's own cash resources. Credit of one kind or another accounted for only 14 % of pump purchases. The most popular form of credit was obtained through membership of an RDRS small farmers' group. Formal and informal credit were insignificant. Except for the absence of bank credit in Pirganj, the proportion of funds coming from each source was the same in both upazilas. Thus, the high rate of adoption among small farmers seems to reflect the low cost of the pump rather than access to credit.

SOURCE	PIRGANJ	ADITMARI	TOTAL
Own cash	90	73	163
Private loan	4	1	5
Relatives/friends	1	-	1
RDRS credit	9	5	14
Bank loan	-	6	6
Total	104	85	189

3.2 MAINTENANCE

According to RDRS, the treadle pump was designed to be made from local materials so as to be easy to maintain and repair. To test these claims, we examined the type of repairs farmers had made to their pumps.

Pumphead

Table 3.4 shows the repairs made to each pumphead, by year of purchase. Out of 189 pumps for which data were available, 121 (64 %) had required new parts at some point in their working lives. All pumps

TABLE 3.4: FREQUENCY OF REPAIRS TO TREADLE PUMPHEADS, BY YEAR OF PURCHASE

YEAR BOUGHT	NO. OF PUMPS	BUCKET/WASHER	CHECK VALVE	PULLEY	SHORT PIN	PLUNGER	LONG PIN
<1983	21	17	14	9	5	7	4
1984	37	25	11	7	3	2	2
1985	66	30	16	8	4	2	2
1986	51	11	6	1	3	-	2
1987	14	-	3	1	-	-	1
Total	189	83	50	26	15	11	10

over four years old had some new parts. The most common spare part was the bucket/washer. About 45 % of pumpheads had replacement seals between the plunger discs. The second most common repair was to the check valve. Both washers and check valves are made from old rubber tyres, which are available locally. About 14 % of the pumps also had new wooden pulley wheels. The metal parts of the pump – plunger, short pin and long pin – were the hardest wearing parts.

Superstructure

Repairs were also made to the treadles and frame. The survey showed that, for a pump purchased in 1982, both treadles and frame had been replaced an average of three times. Pumps purchased three years

ago, in 1983-84, have had their treadles and frame replaced twice, on average. Pumps purchased two years ago, in 1985, have had their treadles and frame replaced once. Thus, farmers replace the superstructure once every two or three years.

Maintenance

The decisive test of the pump's construction is the number of pumps which remain operational. Our survey found that out of 189 pumps in the sample, 175 or 93 % were operational at the time of the survey. The most common fault was a blocked suction pipe caused by pumps badly sited on sandy soil which clogged the filter.

Mobility

Mobility is one of the design features of the treadle pump. The pumphead is easily portable and one pumphead can be moved to irrigate fields from different bores. This is an important asset in Bangladesh where plots are small and fragmented. Critics of DTW technology have noted the contradiction implicit in using pumps which have large command areas in a country where the average farm size is only 0.93 ha¹². Unless farmers agree to share water equitably, inefficiencies may result. By contrast, treadle pumps have small command areas and can be moved from plot to plot. Brammer has noted how, by shifting pumps between their fields, farmers in Kushtia district were able to irrigate up to 2 ha of *rabi* crops from one HTW¹³.

Farmers were asked if they moved their pumpheads from field to field. Only 15 out of 189 pumps were reported to be mobile. Nearly all the mobile pumps were located in Aditmari upazila. Thus, mobility for irrigation purposes does not seem to be an important feature of the treadle pump. Instead, mobility reflects the adaptation of the pump to provide drinking water.

Theft

In retrospect, the major design fault of the treadle pump is that it can be easily stolen. The pumphead is usually sealed to the suction pipe with tar to prevent leaks. This makes it difficult to remove the pumphead when the pump is not in use. To prevent theft, farmers sometimes erect shelters in the rice fields and sleep beside their pumps

at night. Many farmers reported that they had had pumpheads stolen. Twenty-two percent of adopters in Aditmari reported theft of a pumphead; the proportion in Pirganj was 21 %. This represents a significant loss for such small farmers. As a security measure, the North Bengal Agricultural Workshop in Lalmonirhat now makes pumpheads with a screw-in socket which allows the farmer to easily detach the pumphead from the pipe. The first pumpheads with the new design went on sale in 1986.

CONCLUSION

Our survey results showed that high proportion of treadle pumps had reached the RDRS target group of small farmers. About 84 % of adopters cultivated less than 1 ha. The high adoption rate by small farmers reflected the low cost of the pump since about 86 % of the pumpheads in the sample were purchased with the farmers' own cash resources. Our results also confirmed that treadle pumps were relatively easy to maintain and repair. About 93 % of pumps in the sample were found in working order at the time of the survey. The most common repairs were replacing the washers and check valves, which cost very little. Bamboo pedals and frame had to be replaced every two or three years, however. Mobility for irrigation purposes was not an important feature of the treadle pump, except in Aditmari where about 16 % of farmers moved their pumps into the homestead to provide drinking water. In retrospect, a major design fault of the treadle pump is that it can be easily stolen. About 22 % of the sample farmers reported theft of a pumphead.

REFERENCES

1. A. Orr and A. S. M. Nazrul Islam, *The Socio-Economic Impact of the Treadle Pump*, Research Report # 2, Agricultural Economics Division, BRRI, Joydebpur, September 1988. Mimeo, 139 pp.
2. UNDP/FAO, *Agro-ecological Regions of Bangladesh. Land Resources Appraisal of Bangladesh for Agricultural Development*. BGD/81/035 Technical Report # 2, Rome, 1988.
3. RDRS, *Irrigation Manual*, Dhaka, February, 1983, p. 3.

4. S. Bentley, 1986 Rower Pump Survey, Report and Tables, MAWTS, Dhaka, February, 1987, p. 3.
5. S. Bentley, Second Rower Pump Survey, 1986-87 Season, MAWTS, Dhaka, October, 1987. p. 4.
6. M. A. Miyan, M. Hassan, and M. Hassan, Manually Operated Shallow Tubewells for Irrigation, Institute of Business Administration, University of Dhaka, March, 1980, p. 37.
7. M. Ahmad and I. Ahmad, Socio-economic survey of the beneficiaries of the IDA assisted hand tubewells project, Consortium of University Teachers for Evaluation, Training and Research, Dhaka, 1987, pp. 2-1, 3-19.
8. M. A. S. Mandal, "Hand Pump Irrigation in Bangladesh: A Comment", *Bangladesh Institute of Development Studies*, vol. VI. No. 1 (Winter, 1978), pp. 111-113.
9. M. Hossain, An economic analysis of hand tubewell irrigation in a selected area of Jamalpur district of Bangladesh, Unpublished M.Sc. dissertation, Department of Agricultural Economics, Bangladesh Agricultural University, Mymensingh, August, 1982.
10. Miyan et. al., p. 76.
11. Miyan et. al., p. 75; Ahmad and Ahmad, p. 3-27.
12. C. Edwards, S. Biggs, and J. Griffiths, *Irrigation in Bangladesh: On Contradictions and Underutilised Potential*, University of East Anglia, England, Development Studies Discussion Paper No. 22, February, 1978. p. 14.
13. H. Brammer, "Some Innovations Don't Wait for Experts: a report on applied research by Bangladeshi peasants", *Ceres*, vol. 13, No. 2 (March-April 1986), p. 28.

4

CROPPING INTENSITY AND EMPLOYMENT

Bangladesh urgently needs to increase production and employment in agriculture. Irrigation can play an important role in this process. Since the limits of cultivable land have already been reached, the only way to increase production is to raise productivity by improving yields or increasing the number of crops that can be grown during the year. Irrigation can raise yields and also raise cropping intensity by allowing farmers to grow crops during the dry winter season when land is normally left fallow.

Irrigation can also play an important role in creating employment. By increasing cropping intensity, irrigation can increase the demand for labour in crop production. Manual irrigation can also create employment directly through the labour required for manual pumping. The scale of underemployment in agriculture is large, and growing. It is estimated that between 1961-1981 only 25 % of the increase in the rural labour force was absorbed by agriculture¹. Projections made for the Third Five-Year Plan (1985-1990) suggest that crop production will absorb only about 40 % of the additional population in this period². Against this background, the treadle pump offers a urgently-needed means of employing surplus labour.

This chapter examines how far the treadle pump has contributed to these two objectives. Section one analyses the impact of the pump on cropping intensity through expanding the area under cultivation in the dry season. It also examines the role the pump has played in the adoption of modern rice varieties (MVs). The second section looks at the pump's effect on employment and the type of labour used for irrigation.

TABLE 4.1: CROPPING INTENSITY ON UNIRRIGATED LAND AND ON LAND IRRIGATED BY TREADLE PUMP.

SEASON	CROP	(PERCENT)	
		UNIRRIGATED	IRRIGATED BY TREADLE PUMP
<i>Aus</i>	MV rice	1	25
	LV rice	47	33
	Jute	6	9
	Other crops	22	22
	Fallow	23	11
	Cropped area	100	100
<i>Aman</i>	MV rice	19	54
	LV rice	44	19
	Other crops	16	5
	Fallow	22	22
	Cropped area	100	100
<i>Boro/rabi</i>	MV rice	-	29
	Pulses	14	4
	Oilseeds	9	-
	Wheat	18	12
	Tobacco	-	46
	Vegetables	9	16
	Other crops	6	2
	Fallow	44	2
	Cropped area	100	100
Total cropped area (ha)		135.23	94.45
Net cropped area (ha)		64.16	38.13
Cropping intensity (%)		211	248

4.1 CROPPING INTENSITY

Bangladesh has three cropping seasons, known as *Aus*, *Aman*, and *Boro*. Rice varieties are grouped according to the season in which they are grown. *Aus* rice is direct-seeded in April/May and harvested in July/August. *MV Aus* is sown in seedbeds in March, transplanted in April/May, and harvested in July/August. *Aman* rice is either direct-seeded in March/April, or sown in seedbeds in July and transplanted in August/September. Harvesting takes place in November/December. Finally, *Boro* rice is transplanted in February/March and harvested in June/July.

Cropping intensity measures the number of crops grown in a single year from a given piece of land. It is defined as:

$$\frac{\text{Gross temporary cropped area}}{\text{Net temporary cropped area}} \times 100$$

Table 4.1 compares cropping intensity on unirrigated land and land irrigated by treadle pump in the survey area. Cropping intensity on land irrigated by treadle pump was 248 % compared to 211 % on unirrigated land. The difference in cropping intensity was due to more intensive use of irrigated land in the *Boro* and *rabi* seasons. In the *Boro/rabi* season, only 2 % of irrigated land was left fallow compared to 44 % on unirrigated land. Thus, the treadle pump has increased cropping intensity and increased crop production in the dry winter season.

Much of the land now irrigated by the treadle pump was already irrigated by traditional methods before the introduction of the pump. Indeed, it will be recalled that the treadle pump was originally conceived as an alternative to inefficient methods of manual irrigation. To discover the real impact of the pump on cropping intensity, therefore, it is necessary to compare the change in irrigated area before and after the introduction of the treadle pump.

Table 4.2 shows that, on average, only about 31 % of the land now irrigated by treadle pumps was previously unirrigated and fallow in the winter season. The proportion of land which was fallow before the pump differed significantly between upazilas. In Aditmari, only 14 % of land now irrigated by treadle pump had lain fallow before the pump was introduced, whereas in Pirganj the proportion was 63 %. Thus, the

TABLE 4.2: AREA OF LAND IRRIGATED BY TREADLE PUMP AND PREVIOUSLY FALLOW IN THE BORO/RABI SEASONS, BY UPAZILA AND LAND TYPE

LAND TYPE	(PERCENT)		
	PIRGANJ	ADITMARI	TOTAL
High	17	9	10
Medium	31	20	22
Low	93	39	88
Average	63	14	31

impact of the treadle pump on cropping intensity has been mixed. On high and medium land, there has been little increase in the area cropped during the dry season. Farmers in Aditmari have simply substituted one form of manual irrigation for another. The impact has been much greater on low land, where the high output from treadle pumps has made it feasible for farmers to grow irrigated rice.

Cropping patterns

The treadle pump has led to significant changes in cropping patterns or the sequence of crops grown by farmers. On high land, farmers with treadle pumps generally grow two modern rice varieties followed by tobacco. On medium land, farmers grow a local rice variety in the *Aus* season, a modern rice variety in the T. *Aman* season, and tobacco. On low land, farmers grow a local T. *Aman* rice followed by a modern variety in the *Boro* season.

Modern rice varieties (MVs)

It is clear that treadle pump irrigation has acted as a "leading input" by facilitating the spread of MV rice. In Pirganj upazila, we found that the treadle pump had allowed farmers to grow MV *Boro*. Out of 46 farmers irrigating *Boro* rice by treadle pumps, only four grew MV *Boro* before adopting the pump. After adoption of the treadle pump, 42 farmers started to grow MV *Boro*. In Aditmari, by contrast, the pump has facilitated the adoption of MV *Aus*. Out of 48 farmers who irrigated *Aus* rice by treadle pump, only four grew MV *Aus* before adopting the treadle pump. After adoption, 44 farmers began growing MV *Aus*.

Both developments were directly due to the treadle pump. Irrigation is essential for *Boro* rice which is grown in the dry winter season. Similarly, multilocation testing of the MV *Aus* - MV T. *Aman* pattern by BRRI has demonstrated that in north-west Bangladesh the pattern MV *Aus* - MV T. *Aman* cannot be grown without irrigation because the growing season in this region is too short for the pattern to give both a high and a stable yield under rainfed conditions³. Without a treadle pump, therefore, farmers in this region could not grow MV *Aus*.

Although the pump has facilitated the spread of MV *Aus* and MV *Boro*, its impact in the *Aman* season has been slight. Out of 148 farmers for whom data were available, only 12 (8 %) regularly used the treadle pump to irrigate T. *Aman*. Farmers will certainly irrigate T. *Aman* in the event of drought, however. A significant number - 35 farmers or 25 % - used the treadle pump to irrigate *Aman* seedbeds. This was more common in Aditmari, where seedbeds were sited on high or medium land which held less water.

TABLE 4.3: NUMBER OF FARMERS GROWING NEW CROPS ON HIGH AND MEDIUM LAND AFTER ADOPTION OF TREADLE PUMP

CROP	HIGHLAND	MEDIUM LAND	TOTAL
Cabbage	39	19	56
Wheat	21	24	45
Tomato	14	12	26
Spinach	18	8	26
Potato	15	10	25
Onion	16	5	21
Eggplant	11	5	16
Radish	8	4	12
Chilli	8	2	10
Garlic	4	5	9
Watermelon	3	1	4

New crops

Irrigation in Bangladesh often leads to a reduction in the number of crops grown as farmers substitute cash and food crops for less valuable crops like pulses and oilseeds. This has happened to some extent with the treadle pump which has reduced the area under these crops (Table 4.1). Yet the pump has also been followed by the introduction of new crops, notably vegetables. We found that 68 % of farmers in the sample had introduced new crops. Table 4.3 shows that the most popular new crops were cabbage and wheat, followed by tomato, spinach, potatoes, and onions. Farmers may favour cabbage over other vegetables because it can be harvested at intervals rather than all at once and thus serves as a convenient source of ready cash. Thus, adoption of the treadle pump has considerably diversified vegetable cropping in the *rabi* season.

4.2 EMPLOYMENT

In this section we examine the type of labour used to operate the pump; labour use by crop; and total labour requirements.

We did not try to collect data on the amount of labour used for manual irrigation because this is difficult for farmers to remember. Instead, we collected data on the type of labour used for pumping for a total of 3-10 days for each farm. Each farmer was asked to recall the hours spent pumping on these days and the kind of labour employed. The results provide a profile of employment by age, sex, and crop.

Type of labour used

The treadle pump has increased employment for family, rather than hired labour. Out of 151 farms in the sample, 75 (50%) reported they used only family labour for pumping; 70 (46 %) reported the use of both family and hired labour; while only 6 (4%) farms reported they used only hired labour.

Table 4.4 shows the proportion of hired and family labour-hours used for pumping in each upazila. The table shows that, proportionately, most of the labour used to operate the treadle pump was contributed by the farm family. About 69 % of total labour-hours used for pumping was provided by family members, while 31% of

TABLE 4.4: FAMILY AND HIRED LABOUR HOURS OPERATING
THE TREADLE PUMP, BY UPAZILA

UPAZILA	(PERCENT)		
	FAMILY	HIRED	TOTAL
PIRGANJ	86	14	100
ADITMARI	63	37	100
AVERAGE	69	31	100

Chi-Square: 12.74 Significant at 0.001 level

Note: family labour weights 1.0 (male), 0.8 (female) and 0.5 (child).

labour-hours were hired. The Chi-square test showed that the proportions differed significantly between upazilas. In Pirganj, about 86 % was family labour; in Aditmari, the proportion was 63 %. The greater use of family labour in Pirganj reflected the higher irrigation requirement for *Boro* rice for which hired labour would have been too costly.

Family labour

It is instructive to compare the participation of men, women, and children in operating the treadle pump. To determine the proportions of each type of family labour, data on labour use for pumping were subdivided into male, female, and child labour. Adults were defined as ages 15-65 and children as ages 6-14.

Table 4.5 shows that men contributed about 81 % of family labour working the pump, women 12 % and children 7 %. The low contribution by women reflects the custom of *pardah*, or seclusion, which generally restricts the participation of Bangladeshi women in farm production to post-harvest operations within the homestead compound. Increasing poverty has forced more women to seek agricultural employment, however, and the female agricultural labour force grew by 10 % per annum over the last ten years^d. In the survey area, it was not unusual to see women working in the fields. Children were often seen working the treadle pump. Typically, children worked with an adult, standing between adult and the bamboo frame or facing the adult on the opposite side of the frame; they rarely worked alone.

TABLE 4.5: TYPE OF LABOUR USED TO OPERATE THE TREADLE PUMP, BY FARM SIZE.

FARM SIZE (ha)	(PERCENT)			
	MALE	FEMALE	CHILDREN	TOTAL
< 0.25	73	20	7	100
0.25-0.49	78	15	7	100
0.50-0.99	85	8	7	100
1.0 >	86	6	8	100
AVERAGE	81	12	7	100

Chi-Square: 11.66 Significant at 0.01 level

Note: Labour weights 1.0 (male), 0.8 (female) and 0.5 (child).

Table 4.5 also shows that the total proportion of pumping hours worked by men increased with farm size, while the proportion worked by women declined. Women on farms above 1 ha contributed just 6 % of family labour-hours for pumping, compared to 20 % of labour-hours on farms below 0.25 ha. The Chi-square test showed that the difference in the proportions was significant at the 10 % level. The explanation may be that on small farms there is more need for men to seek off-farm employment to supplement household income. Wives may then replace their husbands in operating the pump. The proportion of hours contributed by children did not vary by farm size.

Labour use by crop

Farmers used different combinations of hired⁴ and family labour for different crops. Irrigation for *Boro* rice was given almost exclusively by family labour. Only 4 % of labour-hours used for irrigating *Boro* were hired. Similarly, irrigation of vegetables and *Aus* seedbeds were primarily tasks for family labour. About 80 % of irrigation hours used for these activities was contributed by the family and less than 20 % was hired. Hired labour was important for tobacco and wheat, however.

Thirty-seven percent of the irrigation labour for tobacco and 34% for wheat were hired.

The difference is partly explained by the different labour requirements for irrigation. Typically, wheat and tobacco were given only two or three irrigations, whereas *Boro* rice required almost continuous irrigation over a period of two months. Farmers who grew *Boro* told us that it was both expensive and difficult to obtain reliable hired labour (this explains why farmers without enough family labour to irrigate *Boro* rice rent out their pumps to sharecroppers). Farmers cultivating wheat and tobacco told us that labour hired for irrigating these crops was often used for other activities too. A labourer hired for eight hours, for example, might spend only four hours pumping and the remaining four hours in other farm work. Because tobacco is grown in Aditmari while *Boro* is grown in Pirganj, the difference in the proportions of hired and family labour noted between the two upazilas reflects differences in the crops grown.

Labour requirements for irrigating *Boro*

Experience has shown that it is very difficult to collect reliable data on the quantity of labour used for manual irrigation. Even continuous monitoring may not produce reliable results⁵. Some indication of the labour required to irrigate *Boro* rice was obtained from two farmers who kept daily records. The results refer to only two plots for a specific area and should not be generalised. To estimate labour requirements, we assigned different weights to male, female, and child labour. The results showed that the labour used for pumping was almost identical at 207 or 208 mandays/ha. This is a striking result. The total labour requirement for MV *Boro* rice is estimated at 214 mandays/ha⁶. The average number of days worked in agriculture is less than 200 days per worker per year⁷. That farmers in the survey area were prepared to work such long hours to irrigate rice indicates the lack of alternative employment in the dry winter season.

Net impact on employment

To measure the net impact of the treadle pump on employment, we compared the total number of mandays required for the crops

TABLE 4.6: EMPLOYMENT IN CROP PRODUCTION ON UNIRRIGATED LAND AND LAND IRRIGATED BY TREADLE PUMP, BY CROP SEASON AND BY UPAZILA					
UPAZILA	LAND TYPE	(Mandays / ha)			TOTAL
		AUS	AMAN	BORO	
PIRGANJ	Irrigated	67	100	204	371
	Rainfed	93	107	55	255
	% change	-39	-7	+270	+45
ADITMARI	Irrigated	156	166	228	550
	Rainfed	132	107	65	304
	% change	+18	+55	+251	+81
TOTAL	Irrigated	124	142	246	512
	Rainfed	99	113	57	269
	% change	+25	+20	+332	+90

grown before and after the introduction of the pump. Labour requirements for irrigated and non-irrigated crops were obtained from secondary sources⁸.

Table 4.6 shows that the treadle pump has increased employment in crop production in all three rice seasons. Employment in the *Aus* and *Aman* seasons rose by about a quarter while employment in the *Boro* and *rabi* seasons rose three-fold. The increase in the *Aus* and *Aman* seasons reflected the role of the treadle pump in facilitating the adoption of MV *Aus* and MV T. *Aman*, which is more labour intensive than LV rice.

The table shows that the impact of employment varied between regions. In Pirganj upazila, employment actually fell in the *Aus* and *Aman* seasons after the introduction of the pump. This reflected the change in cropping pattern from mixed *Aus* / *B. Aman* to a single crop of irrigated *Boro* rice. Traditional manual irrigation devices have a similar impact on the cropping pattern, and on employment⁹. In Aditmari, by contrast, employment rose in the *Aus* and *Aman* seasons

through the introduction of MV rice. These findings suggest that the biggest impact on employment occurs in areas where the treadle pump allows the introduction of MV rice.

Our results suggest that the treadle pump has created 243 mandays/ha additional employment in crop production. Assuming a command area of 0.20 ha (0.5 acres), this is equivalent to about 50 mandays per pump, excluding the labour required for pumping.

CONCLUSION

This chapter explored the impact of the treadle pump on cropping intensity and employment. The results showed that the treadle pump had increased cropping intensity on lowland previously single-cropped with *B. Aman*; on high and medium land, however, there had been little change in cropping intensity. At both sites, the treadle pump had led to the introduction of new crops. Cabbage and wheat were the most popular introductions. Finally, the treadle pump has facilitated the adoption of MV rice. On lowland, the pump has permitted the introduction of MV *Boro*, while on high and medium land the pump has allowed farmers to grow MV *Aus*.

The pump also had a positive impact on agricultural employment. Our results showed that the pump had increased the employment of both family and hired labour. Overall, 69 % of total hours used for pumping were contributed by the farm family, while 31% were hired. Breakdowns of family labour by age and sex revealed average participation rates of 85 % for men, 35 % for women, and 30 % for children. Most hired labour was male, however. *Boro* rice, vegetables, and *Aus* seedbeds were irrigated almost exclusively by family labour, but about 65 % of the irrigation labour for tobacco and wheat was hired. Irrigation for *Boro* rice was very labour-intensive. Two farmers, who kept daily records, used a total of 208 mandays/ha. Overall, the treadle pump created about 243 mandays/ha additional employment in crop production.

REFERENCES

1. GOB, *Final Report on the Labour Force Survey, BBS*, Dhaka, June, 1988, p. 31.

2. M. Muqtada, "Determinants and possibilities of employment expansion in the crop sector." In R. Islam and M. Muqtada, eds., *Bangladesh, Selected Issues in Employment and Development*. ILO, Delhi, 1986, p. 67.
3. N. E. Elahi and N. P. Magor, "Development of the rainfed *Aus* and transplanted *Aman* cropping pattern." pp. 81-99 In *Proceedings of the Workshop on Experience with Modern Rice Varieties in Bangladesh*, 3-7 April, 1986, BRRI, Joydebpur, 1987.
4. GOB, *Labour Force Survey*, p. 80.
5. MCC, *Compendium of MCC Rower Pump Surveys and Irrigation Research*. MCC, Dhaka, 1985, p. 51.
6. MPO, *Agricultural Production Systems*, Technical Report # 14, Dhaka, April 1987, p. 6-6, Table 14-4.
7. World Bank, *Bangladesh: Selected Issues in Rural Employment*. Report No. 4292 –BD. March 11, 1983, p. 11.
8. MPO, *Agricultural Production Systems*, Technical Report # 14, Dhaka, April 1987, Mimeo.
9. Ministry of Agriculture, *Economics of Irrigation in Bangladesh. A Report on Irrigation by Traditional Methods in Bangladesh*. Agro-Economic Research Unit, Working Paper # 6. Dhaka, 1983, pp. 31-32.

5

INCOME

To be a small farmer in Bangladesh is to be poor. The majority of farmers who have adopted the treadle pump fall into this category. Adoption for them is a means of raising income above mere subsistence, and a step towards economic security. In Bangladesh, where rural per capita income is only \$ 160 per year, the treadle pump can have an appreciable impact.

This chapter explores the role of the treadle pump in raising farm income. It was not possible to study income and expenditure in detail and consequently we cannot tell how much of the surplus generated by the pump has remained within the farm household or has been siphoned off through increased indebtedness. Our main objective was to estimate the costs and benefits of irrigation by treadle pump. We also tried to determine whether extra production generated by the treadle pump was directly consumed by the farmer or sold for cash income; which crops generated the most cash income; and whether the pump had made adopters more self-sufficient in rice.

The first section measures the income generated by the treadle pump. The second section examines how farmers use the extra production from their pumps, and changes in food security.

5.1 COSTS AND BENEFITS

To measure the impact of the treadle pump on farm incomes, we used cost-benefit analysis. The costs and benefits of treadle pump irrigation were calculated both on a crop and on a pump basis. The analysis was made using financial prices since these are the prices on

which farmers base their investment decisions. Previous cost-benefit analyses of treadle pump irrigation have assumed a pump life of six years¹. Four years seems more realistic for a tubewell with bamboo rather than PVC pipe². Finally, we used a discount factor of 18 % , which is the annual rate of increase in the value of agricultural land in Bangladesh³

Costs and benefits by crop

Table 5.1 shows the discounted cost-benefit ratios of treadle pump irrigation for five crops. Costs were valued on a cash-cost basis, omitting the value of family labour and non-purchased inputs. All the cost-benefit ratios were 2.5 or better. This result can be interpreted to mean: every Taka of cash invested is worth 2.5 Taka in present values. The highest cost-benefit ratio (3.6) was for vegetables (cabbage). The rich returns from irrigating *rabi* vegetables on highland are confirmed by

TABLE 5.1: COST-BENEFIT ANALYSIS OF TREADLE PUMP IRRIGATION, BY CROP			
CROP	(Taka/ha)		
	CASH COSTS	BENEFITS	BENEFIT/COST RATIO
Cabbage	6,083	22,145	3.6
Tobacco	2,672	8,556	3.2
MV <i>Boro</i> rice	2,279	6,638	2.9
Wheat	3,086	7,996	2.6
MV <i>Aus</i> rice	2,400	6,017	2.5

Note: cash costs and benefits have been discounted at 18 % over a 4-year pump life.

other surveys of manual irrigation⁴. High price fluctuations make this a risky crop, however. Tobacco had a higher cost-benefit ratio than MV *Boro* rice. The ratios for wheat and MV *Aus* rice were almost identical.

Costs and benefits by pump

We also estimated costs and benefits of owning a single treadle pump. Once more, costs were valued on a cash-cost basis. The results

TABLE 5.2 COST-BENEFIT ANALYSIS OF TREADLE PUMP IRRIGATION (1986/7 constant prices)					
YEAR	1	2	3	4	TOTAL
CASH COSTS (TAKA)					
Capital items:					
Twin treadle pump	630	-	-	-	630
Production costs:	892	892	892	892	3568
Crop production	246	246	246	246	984
Maintenance costs:	-	83	83	83	250
Gross cash costs:	1768	1221	1221	1221	4448
Gross benefits:	4740	4740	4740	4740	18960
Net Cash Flow	2972	3848	3848	3848	14516
Discount Factor					
(18 %)	0.847	0.718	0.609	0.516	-
Net Present Worth	2517	2763	2343	1986	9609
Discounted Costs	1497	877	744	630	3748
Discounted Benefits	4015	3403	2887	2446	12751

Note: command area 50 decimals. Net Present Worth: Taka 9,609 Cost-benefit Ratio: $12,751/3,748=3.4$ Internal Rate of Return (IRR): 50.9 %.

cover both the *Rabi/Boro* and *Aus* seasons. Again, we assumed a pump life of four years, and a discount factor of 18 %. The results are shown in Table 5.2. The table shows that the cost-benefit ratio was 3.4. Thus, for every Taka invested in irrigation by treadle pump, farmers earned Taka 3.4 in present values. The internal rate of return was 51%. Treadle pump irrigation is, therefore, a highly profitable investment for small farmers with large reserves of unemployed family labour.

Cost-benefit analyses are sensitive to the assumptions made regarding discount factors. The cost-benefit ratio would have been higher had we used a lower discount factor.

It is interesting to compare these results with those from other studies. MPO's cost-benefit analysis, which used a discount factor of

15 % and assumed that nine-tenths of irrigation labour was given by family labour, gave a cost-benefit ratio of 7.1 at market prices⁵. Comparisons with other types of manual irrigation pumps show that the treadle pump has a higher cost-benefit ratio than either the rower pump or the No. 6 handpump⁶.

Payback period

Table 5.1 shows that the average annual net cash flow from treadle pump irrigation for farmers owning a single pump was Taka 3,405 (\$ 109). The cost of the treadle pump was Taka 630 (\$ 20). Thus, farmers can repay the cost of the pump in only one season. This result was confirmed by asking farmers directly how many seasons were needed to recover the cost of the pump. Out of 148 farmers for whom data were available, 138 or 93 % recovered the cost of the treadle pump in just one season.

Breakeven point

How much land does a farmer need to irrigate to recover the cost of his treadle pump? The answer was found by regressing the net annual cash flow against irrigated area for each farm owning a single treadle pump (Figure 8). The least squares line shows the annual cash flow

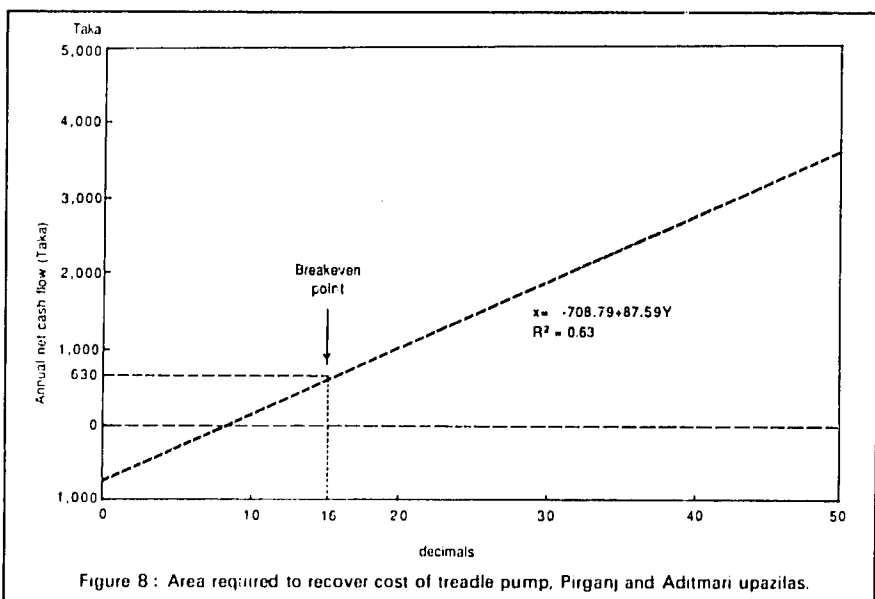

generated for each decimal of irrigated land; it shows that farmers can recover the cost of the treadle pump (Taka 630) by irrigating just 16 decimals or one-sixteenth of an acre. A similar analysis for the rower pump gave identical results: farmers could recover the cost of their investment by irrigating 15-20 decimals of land⁷.

5.2 INCOME AND SECURITY

How do farmers use the income generated by their treadle pump? We asked farmers whether crops they irrigated with treadle pumps were sold or consumed by the farm household. Of course, some crops are both sold and consumed. Farmers were asked, however, to estimate the primary end use of the crop. The results provide an approximate guide to how farmers use production from their treadle pumps.

Table 5.3 shows that most crops were sold for cash rather than consumed. Tobacco, of course, is a cash crop. But food crops like vegetables, potato, wheat, and *Boro* rice were also used primarily as a source of cash income. *Aus* rice was the only crop which more farmers consumed than sold. Results were very similar for each upazila.

Why do farmers use their crops for cash rather than consumption? The winter cropping season after the main *Aman* harvest in December is usually a period of relative prosperity. Nutrition surveys have shown

TABLE 5.3: SALE AND CONSUMPTION OF CROPS IRRIGATED BY TREADLE PUMP			
CROP	(PERCENT)		TOTAL
	SOLD	CONSUMED	
Tobacco	100	-	100
Wheat	82	18	100
<i>Boro</i> rice	79	21	100
Vegetables	73	27	100
Chilli	71	29	100
Potato	61	39	100
<i>Aus</i> rice	45	55	100

that the level of food intake from all sources and the intake of calories and protein are highest in the months of February-April⁶.

On the other hand, farmers also need cash to purchase inputs for the next cropping season. Agriculture in Bangladesh is highly seasonal. Employment, wages, and prices all move in a rhythm dictated by the timing of crop production. Rice prices normally peak in October, before the harvest of the main *Aman* rice crop, and again in April before the harvest of *Boro*. The April price rise coincides with the need for cash income to purchase inputs for the *Aus* crop which is transplanted in May and the farmer is squeezed between the needs for current consumption and future production. Thus, the need for cash income during this period is acute. In addition, farmers may need cash to pay back loans contracted in the slack season before the *Aman* harvest.

Ranking of crops by cash income

Farmers were asked to rank the crops they irrigated by treadle pump, and which they sold, according to their importance as a source of cash income. Tobacco was the single most important crop for cash income. Out of 144 farmers for whom data were available, 74 (51 %) reported that tobacco was their most important source of cash income. This result reflected the predominance of tobacco in Aditnari upazila. Thirty-one farmers (22 %) reported *Boro* rice as their most important cash crop, reflecting the importance of this crop in Pirganj upazila. Interestingly, vegetables were a more important source of cash income than wheat. Twenty-one farmers gave vegetables as their most important source of cash income, compared to just 11 for wheat. Wheat continued to be an important source of cash income, however. Thirty farmers reported wheat as their second most important source of cash income, and 23 as their third most important source.

Self-sufficiency in rice

Food security is important for small farmers who are not self-sufficient in rice and depend on the market to feed their families. The majority of farmers owning treadle pumps were not self-sufficient in rice. Out of 148 farms for which data were available, 119 or 83 % normally purchased rice. By permitting the adoption of modern rice

TABLE 5.4 NUMBER OF FARMS BUYING RICE IN EACH MONTH BEFORE AND AFTER ADOPTION OF THE TREADLE PUMP, BY UPAZILA

MONTH	PIRGANJ		ADITMARI		ALL	
	AFTER	BEFORE	AFTER	BEFORE	AFTER	BEFORE
1. <i>Boishak</i>	30	29	27	35	57	64
2. <i>Joistho</i>	24	32	17	28	41	60
3. <i>Asar</i>	27	36	-	3	27	39
4. <i>Srabon</i>	28	32	1	4	29	36
5. <i>Bhadro</i>	3	4	16	22	19	26
6. <i>Aswin</i>	15	15	26	36	41	51
7. <i>Kartik</i>	42	38	10	22	52	60
8. <i>Agrahayon</i>	2	5	5	4	7	9
9. <i>Pous</i>	4	5	6	4	10	9
10. <i>Magh</i>	6	7	8	6	14	13
11. <i>Falgun</i>	9	12	12	17	21	29
12. <i>Choitro</i>	22	23	23	27	45	50

Note: Only farms adopting treadle pumps in 1985, 1986 or 1987 are included.

varieties, the treadle pump has increased the ability of small farmers to feed themselves. To measure the impact of the treadle pump on self-sufficiency in rice, farmers were asked to remember the months when they purchased rice before they had adopted the treadle pump compared to the number of months they purchased rice now. We know that this is not an ideal method for determining changes in rice purchases. It assumes that other variables which determine supply and demand for rice in the farm household remained constant. In practice, family size and farm size may change. To reduce the bias introduced by changes in other variables, we have presented the results only for those farmers who adopted the treadle pump within the last three years, from 1985 onwards.

Table 5.4 shows the monthly distribution of rice purchases before and after adoption of the treadle pump. Scanning the pattern for both upazilas, self-sufficiency appears to have increased for 10 months out of 12. There has been little change, however, in the three months (*Agrahayon*, *Pous*, and *Magh*) following the harvest of *T. Aman*. We noted earlier that the treadle pump was rarely used for irrigating *T. Aman*.

By contrast, the treadle pump has significantly improved rice self-sufficiency in the *Aus* and *Boro* seasons. These results are consistent with our earlier findings. As expected, the improvement in Pirganj upazila has occurred after the harvest of *Boro* while in Aditmari upazila it has taken place after the harvest of *Aus*. In Pirganj, fewer farmers now bought rice in *Joistho*, *Asar*, and *Srabon*. This reflected the expansion of *Boro* cultivation on previously fallow land. In Aditmari, fewer farmers now bought rice in *Bhadro*, *Aswin*, and *Kartik*. This reflected the adoption of modern *Aus* varieties after purchasing the treadle pump. We conclude that the treadle pump has significantly improved rice self-sufficiency on small farms.

CONCLUSION

Our survey results showed that the treadle pump had significantly increased farmers' incomes, both in terms of generating cash for purchases and improving their self-sufficiency in rice. The majority of farmers said that their incomes had risen after adopting the treadle pump. This was confirmed by a cost-benefit analysis of treadle pump ownership which gave a cost-benefit ratio of 3.4. Moreover, most farmers recovered the cost of the pump in just one season. It was estimated that farmers could recover the cost of the pump by irrigating just 16 decimals of land. The pump appears to have been used primarily as a way of generating cash income. Most of the crops which farmers irrigated by treadle pump were sold rather than consumed. In Aditmari, the most important cash crops were tobacco and wheat, while in Pirganj the most important were *Boro* rice and vegetables. Very few of the farms in the sample were self-sufficient in rice. By adopting the treadle pump, however, farmers were able to reduce their rice purchases. In Pirganj, the treadle pump improved rice self-sufficiency after the harvest of *Boro*, while in Aditmari self-sufficiency had improved after the harvest of *Aus*.

REFERENCES

1. Engineering and Planning Consultants, Testing of Handpumps under IDA-assisted HTW Project (Credit 1140-BD), Draft Final Report, August, 1987; Q. Shahabuddin, M. Ali, and K. Pitman, A Literature Survey of Manual Pump Irrigation in Bangladesh, Harza Engineering Co. International, Dhaka, July, 1987.
2. G. Barnes, "Low cost irrigation: bamboo tubewells and treadle pumps", *ADAB News*, Vol. VIII, No. 11 (March-April, 1981), p. 7.
3. M. Hossain, *Green Revolution in Bangladesh. Impact on Growth and Distribution of Income*, University Press Limited, Dhaka, 1989, p. 51.
4. MCC, Compendium of MCC Rower Pump Surveys and Irrigation Research, Dhaka, 1985, p. 81.
5. Shahabuddin et. al., 1987, p. IV-9.
6. Shahabuddin et. al., 1987, p. IV-9; Engineering and Planning Consultants, 1987, p. 103.
7. S. Bentley, 1986 Rower Pump Survey, Survey Report and Tables, MAWTS, Dhaka, February, 1987, p. 8; MCC, 1985, p. 54.
8. R. H. Chowdhury, "Some Aspects of Seasonal Dimensions to Rural Poverty in Bangladesh," Paper presented at the Conference on Seasonal Dimensions to Rural Poverty, Institute of Development Studies, University of Sussex, England, July 3-6, 1978, pp. 14, 68 Table 19.

6

CASE STUDIES

"Before you teach the farmers," a Chinese proverb advises, "listen to them". Our objective in this chapter is to listen to the experience of two farmers who have adopted the treadle pump. The chapter covers the same issues discussed in previous chapters but with the greater detail provided by case studies. Two farmers were purposively selected for interview. We deliberately selected farmers belonging to the RDRS "target group", operating farms of less than two acres (at present the ceiling is under one acre). Our objective in selecting these farmers was to learn more about the production potential of the new technology from those farmers for whom it was designed.

The information presented below was obtained by personal interviews. Each farmer was interviewed several times during the course of field work. Each interview lasted about one hour. A checklist of topics was used to structure the discussion.

6.1 PIRGANJ UPAZILA: SHOPIN

Aged about 40, Shopin Chandra Barman looks younger than his age. With Mongoloid features and a smiling face, Shopin is a stout and industrious man. His father Guhalu Ram Barman, who lived a full life of a hundred years, was also regarded as a hard working farmer. Guhalu died in 1976 and his wife (Shopin's mother) Shinju Bala died four years later in 1980.



Shopin had to work harder than his father did to eke out a living for his family of six - his wife Hemota Bala, two daughters Jharna 9 and Geeta 7, and two sons Nakul 5 and infant Haridas. Shopin lives in Radhikapur village of Pirganj upazila under Thakurgaon district in northern Bangladesh.

Of about 400 families in Radhikapur, an overwhelming majority is functionally landless or near-landless possessing up to one acre of land only. About 80% are illiterate and victims of chronic poverty and malnutrition. Against this socio-economic backdrop, Shopin is rather a successful man. By ensuring irrigation with the treadle pump and thereby maximising utilization of land and productivity, Shopin has prospered well over the past few years

Adoption of pumps

Shopin bought his first treadle pump four years ago after being inspired by the performance of a fellow villager. He was the third farmer in his village to buy the pump. It was a substantial investment for him then - Taka 279 (\$ 9) for the pumphead and installation, while for the tubewell, filter and superstructure, he provided the bamboo from his own clump.

Being encouraged by the results, he bought two more pumps in the two subsequent years. With three treadle pumps Shopin became a well-to-do, marginal farmer.

His farm

After his father's death, Shopin inherited one acre of land and later, as he prospered, bought some more. Now he owns 2.75 acres divided into 18 plots. In the *Boro* season, he leases out 0.88 acres to two sharecroppers and leases in 0.30 acres in the nearby *beel* (marsh). The total size of his farm in the winter cropping season is thus 2.12 acres. His farm has two types of land: high and low. The lowland occupies 1.68 acres and the highland 1.03 acres. The soil on the highland is sandy and drains easily, making it unsuitable for rice. Instead, he usually grows sugarcane and jute. In the *rabi* season, the

highland grows wheat and vegetables. No irrigation is given to the wheat, but his wife waters the vegetables from a household handpump for drinking water (also using bamboo tubewell and strainer), and a hand-dug well near the home compound.

Cropping intensity

All three pumps are sited on lowlying *beel* land. Asked why he chose this location, Shopin gave two reasons. Before buying the pump he already grew three crops a year on his highland but his lowland grew only a single crop of B. *Aman* rice. Thus, there was scope to increase cropping intensity on his lowland. Secondly, he claimed that it required less labour to irrigate lowland crops. Highland soils were sandy and drained easily, making it necessary to irrigate every day. On lowland, irrigation was needed only every three or four days.

Cropping patterns

On the low-lying *beel* land the cropping pattern is fallow, then local T. *Aman* rice followed by *Boro* rice ("China"). The local *Aman* ("Enda") is a tall variety which can either be broadcast or transplanted. "China" is the name farmers in this area give to rice grown in the *Boro* season. The seedbed is prepared in the first week of *Agrahayan* (15-21 Nov.) and the seedlings transplanted at the end of *Poush* (15 Dec-15 Jan) or early *Magh* (16-21 Jan), when they are 6-8 weeks old. The rice is harvested in the first week of *Joistho* (15 May-15 June).

Irrigation management

Shopin's three treadle pumps irrigated five plots of *Boro* rice with a total command area of 1.03 acres. Two of these pumps were provided to his sharecroppers free of cost. One sharecropper irrigated two plots with a command area of 0.68 acres and the second irrigated one plot with a command area of 0.20 acres. Shopin himself operated one pump which irrigated 0.15 acres. From this plot he expected to harvest 10 *maunds* (1.5 mt) of paddy, equivalent to a yield rate of 4 t/ha.

Shopin rented two of his pumps to his sharecroppers because he wanted to help them increase production. Moreover, he could not operate two additional pumps without the help of hired labour. This would have been expensive and there was no guarantee that it would

have been available when needed. The plots are leased out only in the *Boro* season. Shopin cultivates them himself at other times. The sharecropping of Shopin's treadle pump plots thus reflect the high labour requirements to irrigate *Boro* rice.

His two sharecroppers paid him half the crop after deductions for the cost of seed and fertiliser which he had provided. In return, they supplied all the labour for irrigation and crop production. Shopin ploughed the land for one of the sharecroppers who did not own any draught animal; he did not charge for this.

Labour use

Shopin uses only family labour for pumping. This effectively means Shopin himself as his wife does not operate the pump and his children are too young to help. The labour requirement for pumping increases during the season. In the months of *Magh* and *Falgun* (15 January – 15 March) one irrigation every four days is enough. But in *Chaitro* and *Boishak* (15 March – 15 May) he must irrigate every day. Shopin prefers to operate the pump between 5:30-10 a.m. when the weather is cool. He stops irrigation in the first week of *Boishak* (15-21 April) after panicle initiation.

Income

Shopin is a born entrepreneur who has made the most of the new technology to improve his income. Although a small farmer in terms of land operated, Shopin is relatively well off. His farm supports his family of six members and produces a surplus for sale. His agricultural income comes from rice, sugarcane, wheat, pulses and vegetables. Shopin does not need to buy rice and sells about 30-35 *maunds* (over a tonne) of *Boro* rice each year. Sugarcane is sold to the government sugar mill in Thakurgaon. As a secondary source of income, Shopin operates a mustard oilpress in his yard. He bought the press nine years ago with his own savings. Working four days a week for one or two hours a day, he makes a profit of about Taka 100 (\$ 3) per week. Shopin admitted it would have been difficult for him to afford three treadle pumps without this secondary source of income.

6.2 ADITMARI UPAZILA : DEBENDRANATH

With dark brown complexion and streaks of gray hair, Debendranath is 40 years old. Living in East Dolzol village under Aditmari upazila of Lalmonirhat district, Debendranath was born in a self-sufficient, small farmer family. As a young boy he attended the local primary school for five years, and as the youngest of a family of seven, he spent his boyhood amidst love and care. But as he remembers, with the passage of time, days became harder and harder. After the death of his father in 1974, Debendranath continued to live with three of his elder brothers in a joint family which ultimately broke up eleven years later in 1985.



Socio-economically, Aditmari is a fairly representative area of northern Bangladesh. Located about 12 kilometres northwest of Lalmonirhat town, Aditmari upazila is regularly washed by the mighty Teesta river and is very prone to flood and erosion.

Adoption

Debendranath's first exposure to the treadle pump technology came when his brother bought a second-hand pumphead from a neighbour. He bought his own pump in 1984 for Taka 335 (\$ 11) including pumphead and installation while he himself provided the bamboo. Unfortunately the pumphead was stolen and later he bought a second pump. In addition to this, he is also sharing water from his brother's pump.

His farm

Debendranath inherited 1.75 acres of paternal land. Later he purchased 94 decimals and then sold 44 decimals. This gives him a farm of 2.25 acres including homestead. His farm is made up of 22 plots of high, medium and low land, many of them adjacent to one another.

Cropping intensity

Adoption of the treadle pump has not increased cropping intensity on Debendranath's farm. Only one of the 11 irrigated plots was previously fallow in the *rabi* season. All the others were irrigated by water from a large pond. Instead, the main impact of the pump in the *rabi* season has been to make irrigation more efficient, increase crop yields, and allow a greater variety of crops to be grown.

Today, Debendranath grows wheat and tobacco on his medium land. Before adopting the treadle pump, the land grew pulses in the *rabi* season. Wheat or tobacco, which is an important cash crop, was too costly to irrigate. Water had to be lifted from a pond using a bucket and pole, channelled 275 m to a smaller pond near the homestead, then lifted out again for irrigation. Irrigation by treadle pump is much more efficient and allows the cultivation of higher value crops. In the *rabi* season, Debendranath grows tobacco, vegetables, and wheat. Yields of tobacco and wheat have risen substantially. Tobacco now yields 2.1 t/ha compared to 0.5 or 0.7 t/ha before adopting the pump. Wheat yields have reportedly risen from under 1 t/ha to 2.4 t/ha.

Cropping patterns

The main cropping pattern on Debendranath's irrigated land is *Aus* - *T Aman* - tobacco. Seedbeds for China *Aus* are prepared in the first week of *Falgun* (15 Feb - 15 March) and the seedlings transplanted in the third week. The rice is harvested in mid-June to mid-July. In the *Aman* season, Debendranath transplants BR11 in the month of *Asar* (15 June - 15 July) and harvests from mid-October to early November. Tobacco is then planted after the harvest of *T. Aman* and harvested in early February.

New crops

The treadle pump has also permitted the introduction of new crops. Wheat can now be grown on medium land. Debendranath also grows an astonishing variety of vegetables (cabbage, cauliflower, tomato, potato, carrot, spinach, aroid, kangkong). Of these, cabbage has the advantage of being harvested gradually, a few plants at a time, providing a convenient source of cash when needed. The most

important change, however, has been the introduction of modern *Aus* rice. Before adopting the treadle pump, Debendranath grew a direct seeded, local *Aus* ("Palashi") rice which yielded 1.5–2.0 t/ha. The treadle pump has made it possible to grow a transplanted, modern variety (BR1) which yields 4 t/ha.

Labour use

Although Debendranath's wife and eldest son help him operate the treadle pump, he often has to rely on hired labour. Demand for pump labour is highest in the *Aus* season when Debendranath hires in about 20-25 days of labour. In the *rabi* season, the pump is operated mainly by family labour. Debendranath estimated he hired in about 15 days' labour to help irrigate his tobacco, but this labour also helped with other crop operations besides irrigation. Compared with *Boro* rice, *rabi* crops need relatively little irrigation.

Income

By allowing the cultivation of MV *Aus*, the treadle pump has made Debendranath more self-sufficient in rice. Before adopting the treadle pump, he bought rice four months in a year. Now he no longer needs to buy rice in *Boishak* (15 April -15 May) because of the higher yields of modern T. *Aman* (this, he says, is not because of the pump but because he now grows BR11 instead of IR8). Similarly, he no longer buys rice in *Kartik* (15 Oct-15 Nov) because the pump allows him to grow modern *Aus*. Debendranath now buys rice only in *Joistho* (15 May-15 June) and *Aswin* (15 Sep-15 Oct), or before the *Aus* and T. *Aman* harvests. As a side business, he sells a little rice each season in the local bazars.

The treadle pump has also increased his income from cash crops. Tobacco yields have increased and in March 1988 Debendranath had already sold 77 kg of tobacco earning Taka 8,520 (\$ 270). Income from vegetables is more difficult to estimate. Roughly, Debendranath earns about Taka 3,000 (\$ 95) from *rabi* vegetables; half of this from cabbage. A significant portion of the produce is also consumed by Debendranath's family.

CONCLUSION

Our two studies illustrate how farmers have responded to the opportunities opened up by the treadle pump. Firstly, manual irrigation in the dry season has created new production possibilities. Shopin now grows *Boro* rice on land he previously left fallow. For Debendrananth higher value crops like vegetables and tobacco have replaced pulses on medium land, while in the *Aus* season modern *Aus* has replaced a direct-seeded local variety.

Secondly, the pump has generated employment both for pumping and crop production. Most of the extra labour is done by the farmer's own family and not by hired labour. Where farmers cannot operate their pumps by family labour they either prefer, like Shopin, to share them with their sharecroppers or rent them out. As yet, however, the number of farmers renting out treadle pumps remains a small minority.

Finally, the treadle pump has significantly increased income. Shopin now sells over one tonne of *Boro* rice each year. Debendrananth has doubled his yields of tobacco, wheat, and *Aus* rice. Some of this surplus is consumed on the farm, and both farmers now buy less rice than they did before. But the pump's most important role has been to provide means of increasing the farmer's cash income. This has provided working capital for production in the next season and has also been used for investment in agriculture. Significantly, both farmers have reinvested in land and more treadle pumps, rather than in non-productive activities like moneylending. This illustrates the high returns from treadle pump irrigation.

CONCLUSION

"A high proportion of success stories tend to involve innovations which were very similar to practices already followed, which were simple and easy to apply, and which provided unusually high returns." John W. Mellor.¹

An appropriate technology meets a felt need, is simple to teach and understand, and uses resources poor people already have². By these criteria, the treadle pump is a good example of appropriate technology for small farmers. This study has shown that its current success can be explained in terms of four factors: appropriate design, low cost, effective marketing, and high cash returns.

The design of the treadle pump appears to have met the need for a cheap, efficient manual irrigation pump which is simple to maintain and repair. Output with the treadle pump with twin cylinders of 3½-inch diameter is about 1.5 – 3 litres/second, which means that an adult male operator can comfortably pump about 20-40,000 litres a day. The treadle pump is thus more efficient than any other manual irrigation pump for lifts of up to 3.5 metres. Its efficiency can be maintained up to the suction limit by using larger cylinders. Treadle pumps are made by small private workshops using locally available materials and spare parts do not pose a problem for maintenance. The most frequent repairs to the pump were replacing the rubber washer and check valves which are made from used tyres and readily available in local markets. The use of local materials also explains the low cost of the pump which makes it particularly attractive to small farmers. In northern Bangladesh in 1988, a treadle pump with a bamboo tubewell could be purchased and installed for about Taka 630 or just \$ 20.

An important aspect of the pump's success has been the creation of a sales network of private dealers provided with technical support and marketing assistance by IDE, an NGO founded to assist the development of small business enterprises. Without this assistance, it is doubtful if such a network could have arisen. Private dealers whose profits depend on how many pumps they sell have every incentive to maximise sales and this has contributed to the rapid spread of the pump throughout Bangladesh. Currently, sales are running at about 65,000 a year.

Our analysis of the pump's socio-economic impact showed that the pump had increased cropping intensity, employment, and income on small farms. The index of cropping intensity on land irrigated by treadle pumps was 248 % compared to 211% on unirrigated land. The increase was due chiefly to more intensive cropping in the dry winter season, when farmers grew tobacco, vegetables, and *Boro* rice.

The pump had also increased employment of family labour during the slack winter season. About 70% of the labour employed for manual irrigation was provided by the farm family while 30% was hired. The work was shared by all members of the household – men, women, and children. Overall, the treadle pump increased employment in crop production by about 90%.

Finally, the treadle pump has significantly increased farm incomes. Over the lifetime of one treadle pump, farmers earned a net return of Taka 3.4 for every Taka invested. This is higher than the returns estimated for other manual pumps. Cash returns were higher for high-value *rabi* crops like vegetables and tobacco than for rice. The pump rapidly repaid the cost of the original investment. Typically, farmers could recover the cost of the treadle pump in one season by irrigating just 16 decimals or one-sixth of an acre. The rate of return on the farmer's capital investment was 51%. Thus, the treadle pump is a highly profitable investment for small farmers who rely chiefly on their own labour.

These findings suggest that manual irrigation can make a significant impact on the lives and welfare of small and marginal farmers who form a large section of the rural poor in Bangladesh. It

uses resources which farmers already have: their own labour and limited land. It encourages them to help themselves, and avoids the need for credit. It offers quick returns for a relatively small cash investment. Above all, in a world where the benefits from new technology have often bypassed small and marginal farmers, it offers them hope for a better future.

REFERENCES

1. J. Mellor, "The Subsistence Farmer in Traditional Economies." In C. Wharton, ed., *Subsistence Agriculture and Economic Development*. Frank Cass and Co., Ltd, London 1970, p. 221.
2. R. Bunch, *Two Ears of Corn. A Guide to People-Centred Agricultural Improvement*, World Neighbours, Oklahoma, 2nd edn., 1985, p. 97.

BIBLIOGRAPHY

1. M. Ahmad and I. Ahmad, Socioeconomic survey on the beneficiaries of the IDA assisted hand tubewells project. Consortium of University Teachers for Evaluation, Training and Research. Dhaka, March 1987. Mimeo.
2. R. Ahmed, "A structural perspective of farm and non-farm households in Bangladesh", *Bangladesh Development Studies*, Vol. XV, No. 2 (July, 1987), pp. 87-112.
3. M. Taher Ali, D. K. Das, S. M. Nazrul Islam, and A. K. Mesbah Uddin, "Treadle pump: assessment of engineering aspects", *Journal of Institute of Engineers, Bangladesh*, Vol. 15 No. 1 (June, 1987), pp. 23-30.
4. G. Barnes, "The Twin Treadle Pump: Manual Irrigation in Bangladesh." pp. 181-194. In IRRI, *Small Farm Equipment for Developing Countries*. IRRI, Los Banos, Philippines, 1986.
5. G. Barnes, "Low-cost irrigation: bamboo tubewells and treadle pumps", *ADAB News*, Vol. VIII, No. 11 (March-April, 1981), pp.7-10.
6. G. Barnes and M. I. Khan. Update on Twin Treadle Pumps. RDRS, Dhaka, April/May, 1990. Mimeo. 24 pp.
7. E. Baumann and R. Fuller, Manual Irrigation in Bangladesh. Swiss Development Corporation, Dhaka, March 1984, Mimeo, 58 pp.
8. S. Bentley, 1986 Rower Pump Survey. Report and Tables. MAWTS, Dhaka, February, 1987. Mimeo, 24 pp.
9. S. Bentley, Second Rower Pump Survey, 1986-87 Season. MAWTS, Dhaka, October, 1987. Mimeo, 61 pp.

10. E. R. Boa and M.R. Rahman, *Bamboo Blight and the Bamboos of Bangladesh*. Forest Pathology Series No. 1. Forest Research Institute, Chittagong. July, 1987.
11. H. Brammer, "Some Innovations Don't Wait for Experts: a report on applied research by Bangladeshi peasants", *Ceres*, Vol. 13, No. 2 (March-April, 1986), pp. 24-28.
12. BRRI, Annual report on determination and identification of ergonomic characteristics of manually operated pumps and pumping devices widely used by the farmers. Agricultural Engineering Division, BRRI, 1988. Mimeo, 21 pp. and 1989, Mimeo, 29 pp.
13. R. Bunch, *Two Ears of Corn. A Guide to People-Centred Agricultural Improvement*. World Neighbours: Oklahoma. 2nd. edn., 1985.
14. R. H. Chowdhury, "Some Aspects of Seasonal Dimensions to Rural Poverty in Bangladesh." Paper presented at the Conference on Seasonal Dimensions to Rural Poverty. Institute of Development Studies, University of Sussex, England, July 3-6, 1978. Mimeo, 90 pp.
15. C. Edwards, S. Biggs, and J. Griffith, *Irrigation in Bangladesh: On Contradictions and Underutilised Potential*. University of East Anglia, England. Development Studies Paper No. 22. February, 1978. Mimeo. 58 pp.
16. N. E. Elahi and N. P. Magor, "Development of the rainfed Aus and transplanted Aman cropping pattern." pp. 81-99. In *Proceedings of the Workshop on Experience with Modern Rice Varieties in Bangladesh. 3-7 April, 1986*. BRRI, Joydebpur, 1987.
17. Engineering and Planning Consultants, Testing of Handpumps under IDA-assisted HTW project (Credit 1140-BD). Draft Final Report. August, 1987. Mimeo, 114 pp.
18. FAO/World Bank, Bangladesh Hand Tubewells II Project Preparation Mission. Report of the FAO/WB Project Investment Centre, 27 June, 1985.
19. D. Gisselquist, Bangladesh Minor Irrigation Subsector study: Economic and Administrative Issues. World Bank, Dhaka, November, 1988. Mimeo, 122 pp.

20. GOB, *Final Report on the Labour Force Survey*. BBS, Dhaka, June, 1988.
21. GOB, *Bangladesh Census of Agriculture and Livestock, 1983-84. Vol 1: Structure of Agriculture Holdings and Livestock Population*. BBS, Dhaka, May, 1986.
22. M.A. Hamid, M.K. Mujeri, M.R. Hasan, M. R. Islam, and M.S. Islam, *Shallow Tubewells under IDA Credit in North-West Bangladesh. An Evaluation Study*. Department of Economics, University of Rajshahi, December, 1982. Mimeo, 224 pp.
23. B. Hartmann and J. Boyce, *A Quiet Violence*, University Press Limited, Dhaka, 1983.
24. M. Hossain, *Green Revolution in Bangladesh. Impact on Growth and Distribution of Income*. University Press Limited, Dhaka, 1989.
25. M. Hossain, "An economic analysis of hand tubewell irrigation in a selected area of Jamalpur district of Bangladesh". Unpublished M.Sc. Dissertation, Department of Agricultural Economics, Bangladesh Agricultural University, Mymensingh, August, 1982.
26. M. A. Jabbar, *Commercialisation of Agricultural Equipment Generated by R&D System in Bangladesh*. World Employment Working Paper. ILO, Geneva, September, 1985. Mimeo, 32 pp.
27. S. A. Khan, *The State and Village Society. The Political Economy of Agricultural Development in Bangladesh*. University Press Limited. Dhaka, 1989.
28. M.A.S. Mandal, "Hand Pump Irrigation in Bangladesh: A Comment" *Bangladesh Development Studies*, vol. VI, No. 1 (Winter, 1978), pp. 111-113.
29. MPO, *Agricultural Production Systems, Technical Report # 14*, Dhaka, April 1987. Mimeo.
30. J. Mellor, "Subsistence Farmers in Traditional Economies." pp. 209-226. In C. Wharton, ed., *Subsistence Agriculture and Economic Development*, Frank Cass and Co. Ltd., London 1970.
31. MCC, *Compendium of MCC Rower Pump Surveys and Irrigation Research*, MCC, Dhaka, 1985. Mimeo, 56 pp.

32. Ministry of Agriculture, *Economics of Irrigation in Bangladesh. A Report on Irrigation by Traditional Methods in Bangladesh*. Agro-Economic Research Unit, Working Paper # 6. Dhaka, 1983. Mimeo, 69 pp.
33. M. A. Miyan, M. Hassan, and M. Hassan, *Manually Operated Shallow Tubewells for Irrigation*. Institute of Business Administration, University of Dhaka, March, 1980. Mimeo, 317 pp.
34. M. Muqtada, "Determinants and possibilities of employment expansion in the Crop Sector." pp. 61-88 In R. Islam and M. Muqtada eds., *Bangladesh, Selected Issues in Employment and Development*. ILO, Geneva 1986.
35. A. Orr and A.S.M. Nazrul Islam, *The Socio-Economic Impact of the Treadle Pump*. Research Report #2, Agricultural Economics Division, BRRI. Joydebpur, September 1988. Mimeo, 139 pp.
36. RDRS, Annual Reports, 1980, 1982, 1985.
37. RDRS, *Irrigation Manual*. February, 1983. Mimeo, 27 pp.
38. RDRS, *Twin treadle Pump and Drinking Pump. Manufacturers' Guide*. Revised version, June, 1984. Mimeo, 15 pp.
39. Q. M. Shanabuddin, M. Ali and K. Pitman, *A Literature Survey of Manual Pump Irrigation in Bangladesh*, Harza Engineering Co. International, Dhaka, July, 1987.
40. R. E. Stickney, V. Piamonte, Q. de Sagun, and I. Ventura, "Human Powered Pump for Low Lift Irrigation". Paper presented at the 1985 Summer Meeting of the American Society of Agricultural Engineers, Michigan State University, East Lansing, June 23-26, 1985.
41. UNDP/FAO, *Agro-ecological Regions of Bangladesh. Land Resources Appraisal of Bangladesh for Agricultural Development*, BGD/81/035 Technical Report # 2. Rome, 1988.

APPENDIX 1 : RDRS TEST RESULTS

TABLE A-1 : DISCHARGE RATES BY SUCTION DEPTH AND CYLINDER SIZE						
Suction Depth	PUMP SIZE Cylinder Diameter					Pump size matching suction depth
Feet	3"	3½"	4¾"	6"	7"	
2					66	7" *
4				56	60	6" * *
6			37	50	48	* *
8		27	37	44		4¾" *
10		26	35			*
12		25	35			*
14		24	33			*
16		22	25			3½" * *
18		21	17			* *
20		21	12			* *
22		16				*
24	14	13				3" * *
26	12					* *
29	10					* *

Note: 1 m = 3.281 ft. 13.2 Imperial Gallons per minute = 1litre/second.

Table A.1 shows test results when the pumps are operated with one medium to light operator, in sustainable performance. Discharges are rounded off, and shown in imperial gallons per minute (GPM). The table is useful when selecting pump size for a given lift (suction depth). The optimal range for each pump may be extended by giving more force on the treadles.

a) Pump size (cyl. dia)	Inches	3"	3½ "	4¾ "	6"	7"
b) Nominal efficiency (Expected output)	l/s	1	2	34	5	
	GPM	13	27	40	53	66
c) Recommended lift-ranges	Feet	23-29	14-24	8-18	6-8	2-6
d) Expected time to Pump 1 acre-inch	Hours	28.56	14.28	9.52	7.14	5.71
e) Time needed to raise water 1" in a 1 decimal basin (Calculated on performance as under b)	Minutes	17.14	8.54	5.71	4.28	3.43
f) Maximum water output (non-sustainable)	l/s	1.9	3.5	4.5	5.3	5.6
	GPM	25	46	60	70	75

It should be noted here that performance as categorized under b are considered sustainable for a medium, well-seasoned operator and are measured in the middle to lower half of the lift ranges under c.

Line d and e show calculations of time needed to pump 1 acre inch and 1 decimal-inch respectively, when assuming a steady performance as under b. Line e provides a handy reference for maximum performance testing. Line f is a curiosity added to show maximum performances under a heavy operator. These outputs cannot be sustained, but are useful when a pump producer wishes to ascertain that his pumps are fully up to standard. If he cannot reach these outputs, he will have to conclude that his pumps may be improved.

APPENDIX 2 : TECHNICAL SECTION

This appendix provides a technical overview of the treadle pump. It is not intended to be a manufacturers' guide, which can be obtained from RDRS. Nor is it intended to provide complete and detailed technical drawings of the treadle pump. Instead, the purpose of this section is to provide engineers with basic information on the pump's specification and construction. Enough detail has been given, however, for interested engineers to make a treadle pump if they wish.

Two variations of the treadle pump are in common use. The original design incorporates a pulley arrangement which links the two plungers and supports the treads on which the operator stands. In this design the pump is installed between the fulcrum and the operator.

The second variant was evolved by farmers themselves and eliminates the need for pulley, pulley pivot, and supporting rope. The return of the plunger is assisted by the weight of overhung sections of the bamboo and the operator stands on the opposite side of the fulcrum from the pump. This arrangement is similar to that found in a *dheki*, the traditional foot-operated mortar and pestle that is still used to husk rice in many rural households in Bangladesh.

While the *dheki* type treadle pump is simpler and cheaper than the earlier model, its output cannot be increased with more forceful pumping as the frequency of the stroke is limited by the gravitational pull on the falling bamboo. Moreover, the counterweight has to be lifted during each working stroke, unlike the pulley pump which is kept in neutral balance by the interconnecting rope.

Figures A1-A6 illustrate the original or traditional treadle pump. The technology has evolved since the original treadle pump was designed in 1980. Accordingly, the drawings illustrate different designs for certain components, namely the cylinders, valves, and plunger rods. Figures A7-A8 illustrate the *dheki* treadle pump. It may be noted that the *dheki* pump uses the same cylinder and plunger rods as the traditional treadle pump.

Figure A1 shows the traditional treadle pump; the original design used since November 1980.

Figure A2 shows some later design improvements for the original treadle pump. These include improvements to the plunger rods, disc valve, and cone coupling ('cap').

Figure A3 shows details of the design improvements illustrated in Figure A2.

Figure A4 shows design improvements to the cylinder valves.

Figure A5 shows different types of plungers and their treadle and rope connections.

Figure A6 with reference to Table A3 shows dimensions of plunger discs and cylinder bottom plates, particularly for the two pump sizes $3\frac{1}{2}$ inches and $4\frac{3}{4}$ inches.

Figure A7 shows the *dheki* treadle pump.

Figure A8 shows the cylinder and plunger rods used with the *dheki* treadle pump.

Figure A9 illustrates the tools used for manual boring (sludge boring) of hand tubewells in Bangladesh.

TREADLE PUMP

Twin cylinder pump.
For tubewell, capacity max. 35 Imp. GPM.

- Bamboo Cutting list**
- A- Treadle post- 2 @ 3'
 - B- Treadle bar - 2 @ 7 1/2'
 - C- Frame post - 2 @ 6'
 - D- Arm-rest
 - E- Pulley beam - 1 @ 26" split in halves, pulley axle is bedded in shallow grooves 18" above cylinder tops
 - F- Treadle guide - 1 @ 26"
 - G- Bamboo pipe- sections @ 20'-24' plus 10' strainer

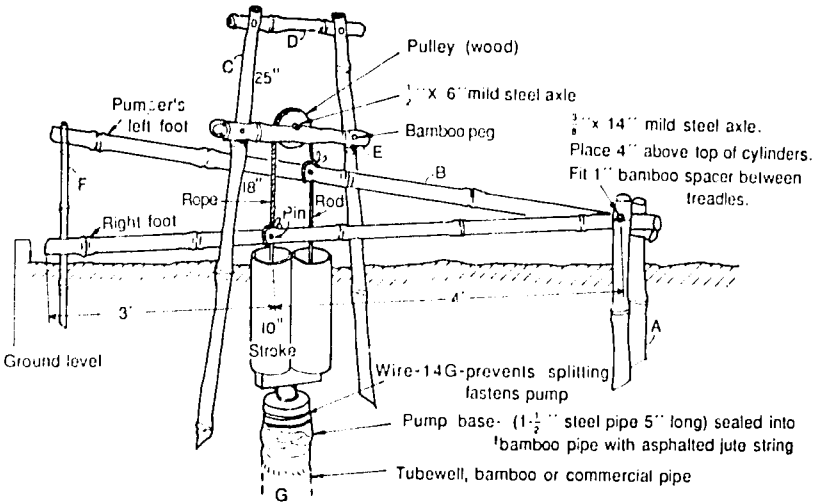
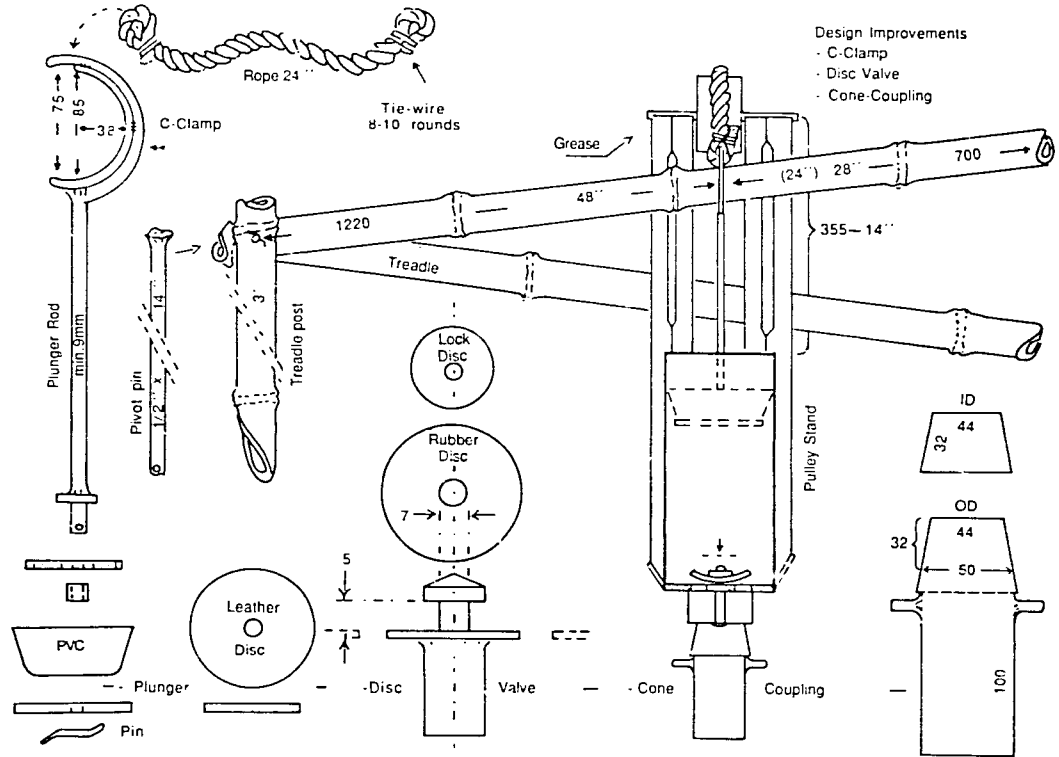

Figure A1 : A traditional treadle pump

TREADLE PUMP

Figure A2 : Design improvements to traditional treadle pump (1990)



TREADLE PUMP – PULLEY TYPE

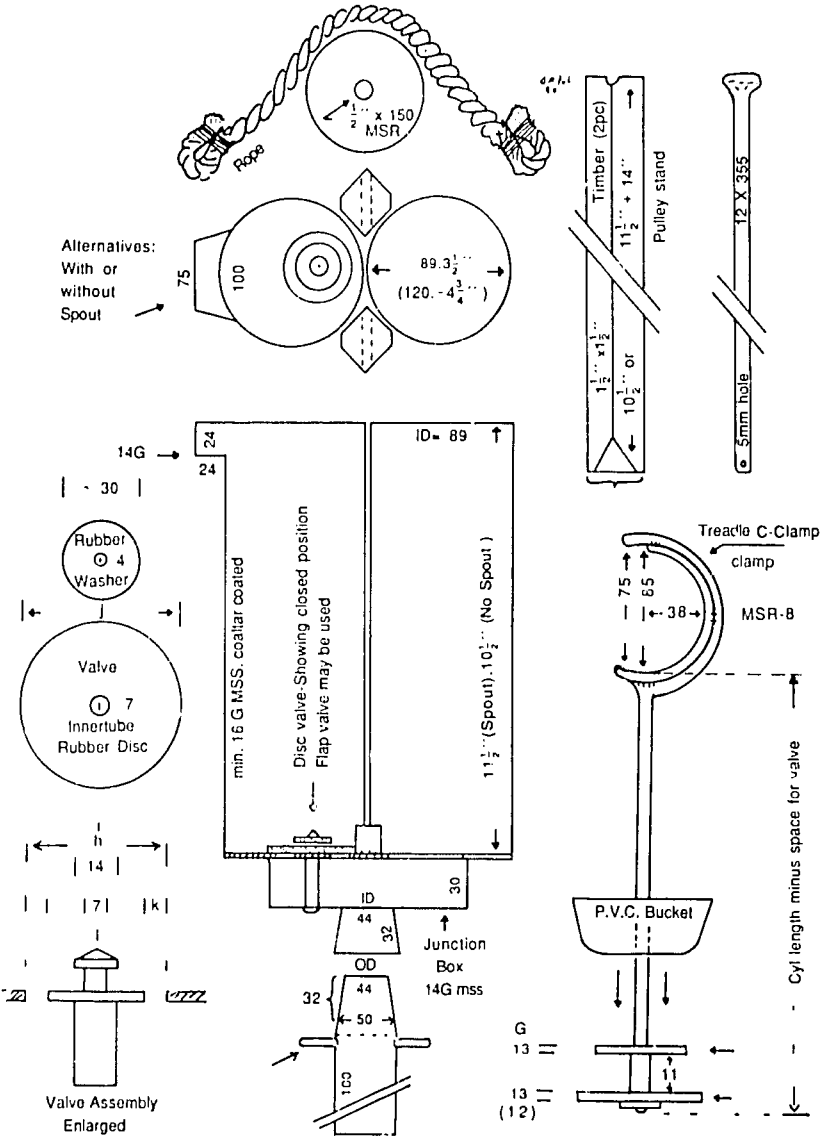

Figure A3 : Details of design improvements to traditional treadle pump

TREADLE PUMP-VALVE ASSEMBLIES

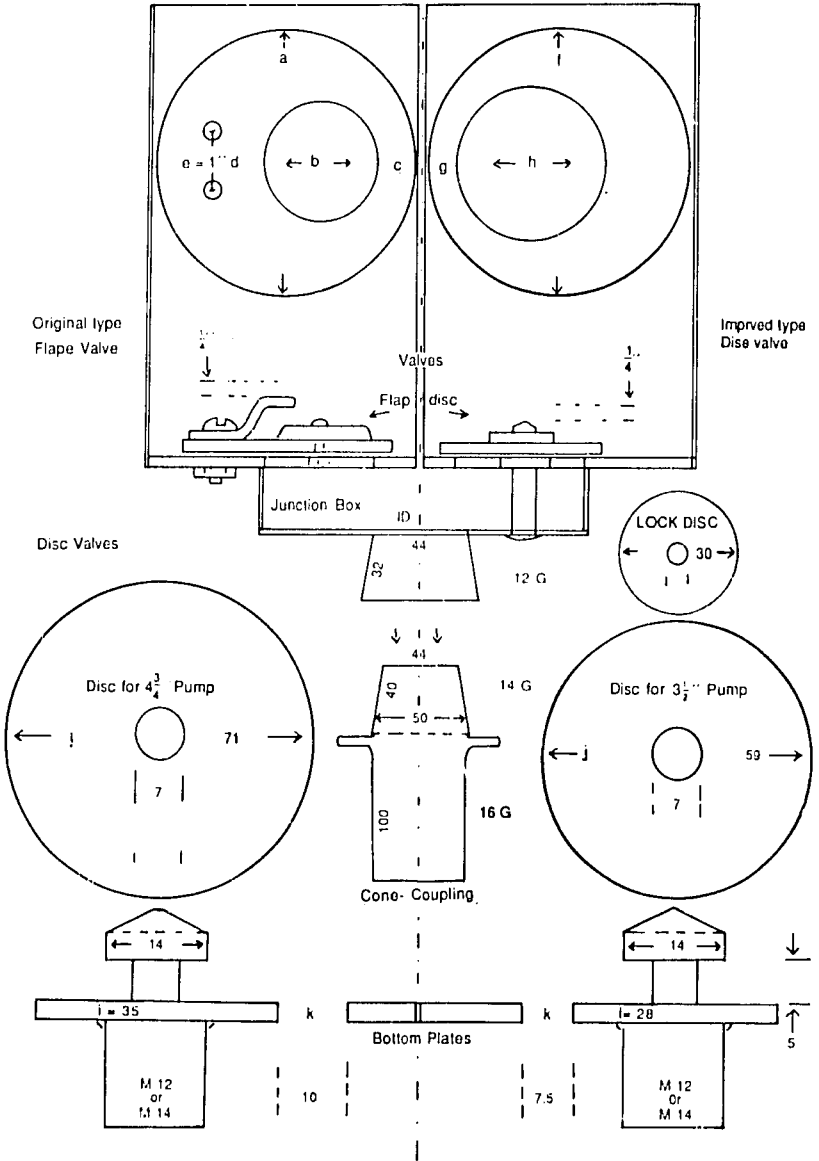

Figure A4 : Design improvements to cylinder valves

TREADLE PUMP – PLUNGER TYPES

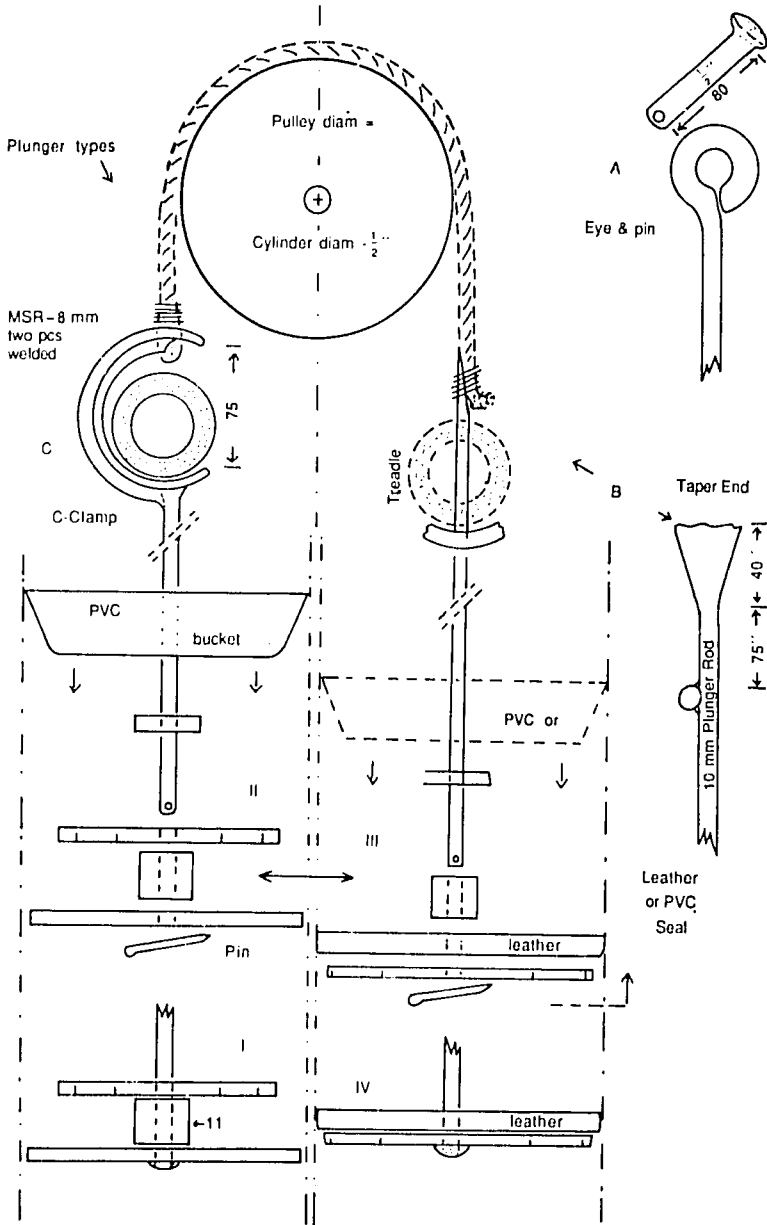

Figure A5 : Design improvements to plungers and their treadle and rope connections

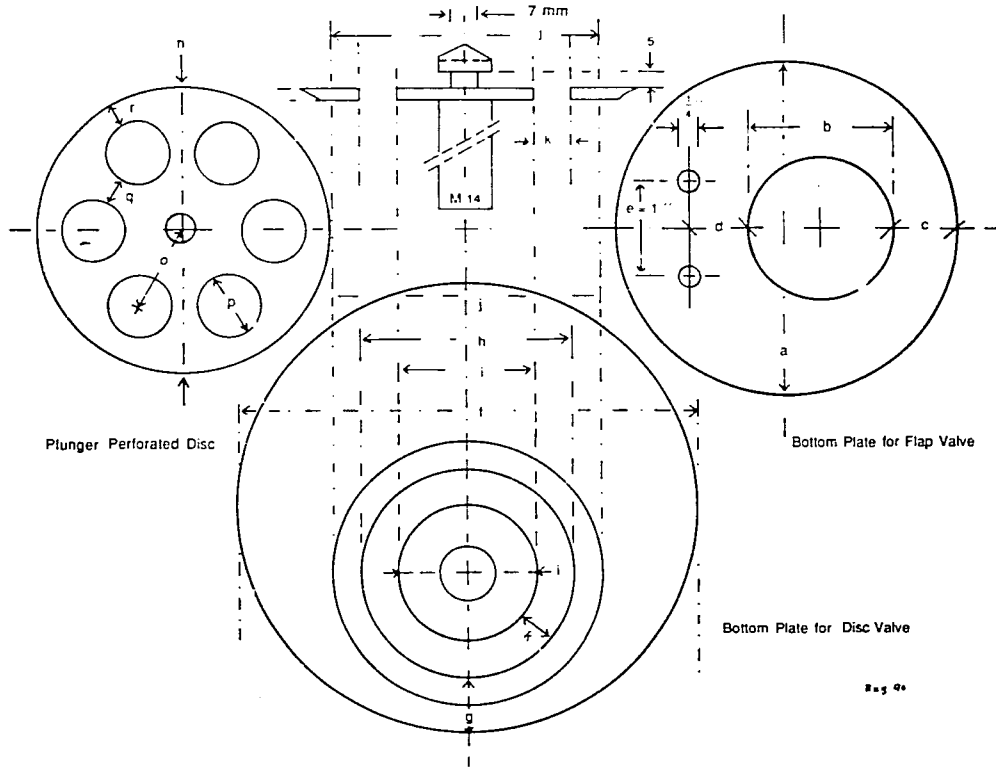

Fig 90

Figure A6 : Dimensions of plunger discs and cylinder bottom plates for two pump sizes (3½ and 4¼ inch diameter)

**TABLE A3 : SPECIFICATIONS FOR 3 $\frac{1}{2}$ AND 4 $\frac{3}{4}$ INCH
DIAMETER TREADLE PUMPS**

DIMENSION CHART				TUBEWELL/LOW-LIFT		REMARKS	
Component	Detail	Symbol	#6 = 3 1/2" 89	4 3/4" 120.5	Inch mm I.D.		
1	Cylinder	Cut square 14-16 SWG	Inch mm	10 1/2" x 11 3/16" 266 x 284	10 1/2 x 15 266 x 381	Add 1" f. Spout Add 1" for <i>Dheki</i>	
2	Junction Box 14 SWG	For Flap Valve	-	305 x 25	358 x 32	Wall of Junction Box	
		For Disc Valve	-	310 x 25	370 x 32		
3	Base Pipe	Actual - mm Nominal - Inch	- -	42 1" 1/2"	46 1 1/2"	Actual in mm I.D. Normally 5" long	
4	Cylinder Bottom Plate 14 SWG (If Crim- ping the Cyl f may be 4-8 mm less)	For Flap Valve	a	89	120.5	Plate dia " Cylinder I.D. * 27 mm in hand pumps.	
			b	38	48		
			c	20	20		
			d	16	16		
		With Disc Valve	f	89	120.5	f - a j - h + 16 mm All Pumps : Pillar - 14 MSR	
			g	12	15		
			h	43	55		
			i	28	35		
			j	59	71		
			k	7.5	10		
5	Plunger Disc per- forated Upto 119 mm dia : 13 SWG Larger : 12 SWG	No. of Holes	-	6	7		
		For PVC bucket	n	74	100	Disc Dia	
			o	20	27	C - C	
			p	16	18	Hole Dia	
			q	5	6	Edge-Edge	
			r	9	14	Edge-hole	
		For Leather Disc	n	88	119	Cyl. Dia + 1 mm	
			o	31	44.5		
			p	16	18		
			q	5.5	7.3		
			r	5	6		
			No. of holes	-	9	11	
		6	Blank Disc Dia	-	80	110	With PVC bucket
		7.	Leather Disc Dia	-	92	123	Cyl. dia + 3 mm

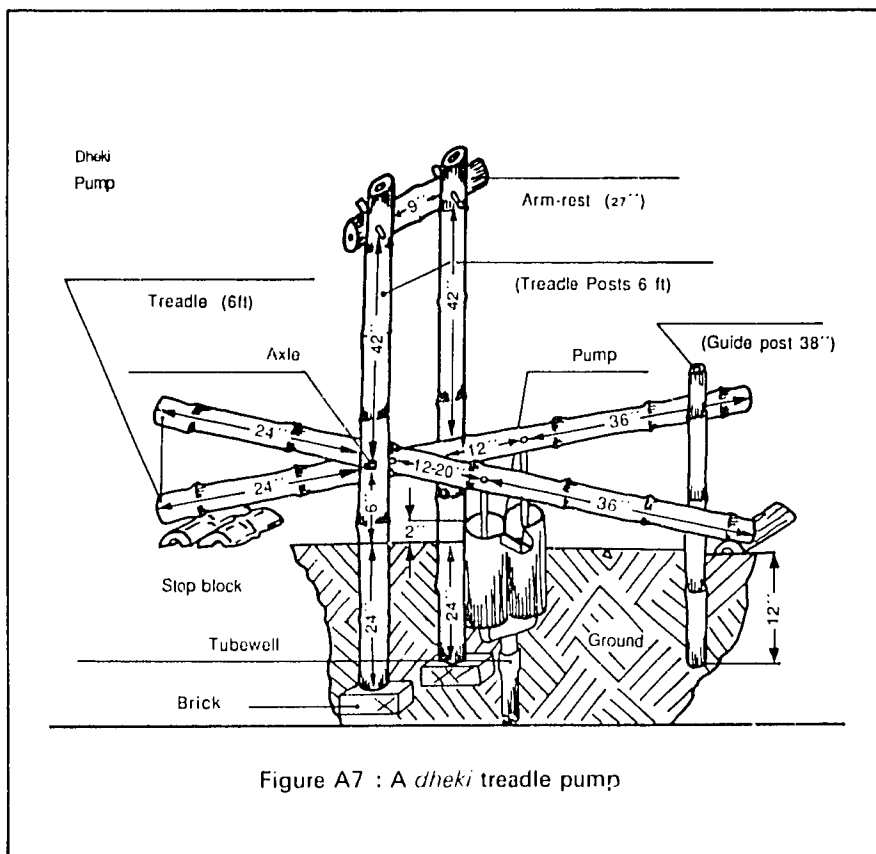

Table A4: SPECIFICATIONS FOR 3½" TWIN TREADLE
PUMP – DHEKI TYPE

	MM.	INCH.
1. Length of Cylinder	313	12 ½"
2. Wall Thickness (Min.)	1.6	16 swg
3. Inside diameter of the cylinder	89	3½"
4. Total net length of the spout	38	1½"
5. Width of the spout (back-front)	130-100	5 ⅛" - 4"
6. Depth of spout, net	25	1"
7. Plunger rod length to eye-centre	330	13"

8.	Diameter of the plunger rod (Min.) (smallest dia measured)	9	$\frac{3}{8}$ "
9.	Lower plunger disc diameter	80	-
10.	Lower Plunger disc thickness (Min.) (13 swg require strong weld)	2.34	13 swg
11.	Upper plunger disc (perforated) diameter	74	-
12.	Upper plunger disc (perforated) thickness	2.34	13 swg
13.	Drill hole Nos. of the upper disc	6 Nos.	
14.	Drill hole dia of the upper disc	17 (16)	$11/16$ ($\frac{5}{8}$ ")
15.	Spacer length between the upper & lower plunger disc (Discs aligned!)	12	$\frac{1}{2}$ " (Max.)
16.	Axle rod dia	12.5	$\frac{1}{2}$ "
17.	Axle rod length (include head and cotter Pin)	356	14"
18.	Cross pin diameter	12.5	$\frac{1}{2}$ "
19.	Cross pin length (between head and cotter pin, net)	80	3 1/8"
20.	Circumference length of the junction box, approx.	300	12"
21.	Depth of the junction box	32	$1\frac{1}{4}$ "
22.	Sheet thickness of the junction box	2	14 swg
23.	Bottom plate thickness	2.34	13 swg
24.	$1\frac{1}{2}$ " G.I./ MS base pipe If welded to junction box, Gauge	2	14
	If screwed into a half-socket	2.64	12 swg
	Base pipe length	125	5"
25.	Disc or Flap valve as per specifications	(See drawings)	
26.	Outside surfaces of the pump should be heavily hot-coated with pitch		

TREADLE PUMP-DHEKI TYPE

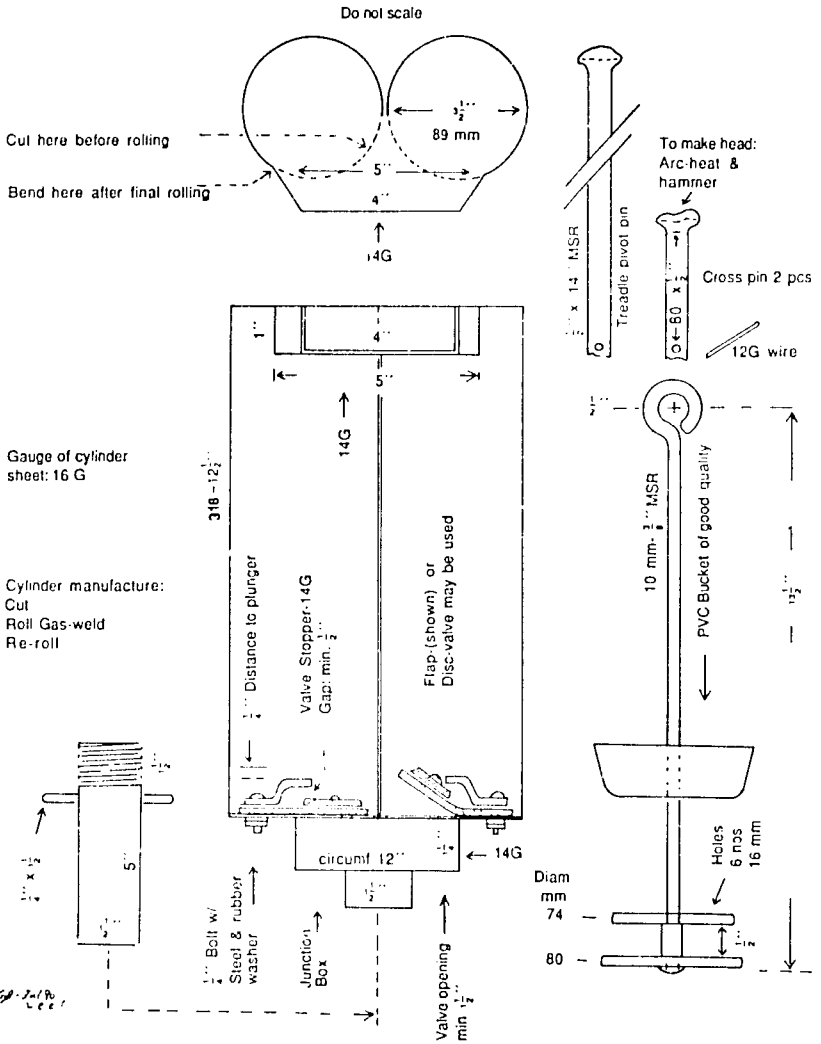
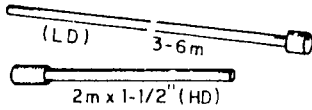
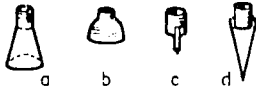

Figure A8 : Cylinder and plunger rods for *dheki* pump

Figure A9 : Manual boring tools in Bangladesh and stages in the drilling process.



Drill stem
GI pipe with sockets



Cutting tools
a Flared socket, or
b Reducing socket
c,d Sockets with chisel point

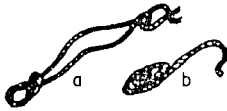

Rope, Jute $\frac{1}{2}$ " - $\frac{3}{4}$ "
a Slip-knotted, in king drill stem to handle
b For tying scaffold



Bucket
Hoe
Hole digger

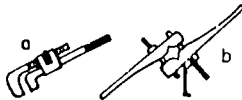

Pipegrip
a Common pipe wrench or
b Simple clamp

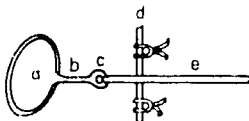

Bird's view
a Sediment pool
b Canal
c Bore hole with drill stem
d Scaffold
e Handle

Operator's hand

Detail

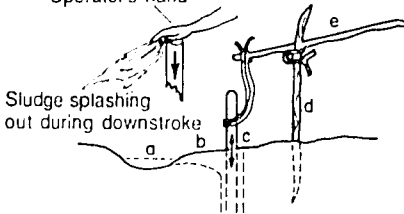

Profile
When working with long drill stem, operator will perch on the cross member. The rope is slid up the pipe as the hole gets deeper.

Using the equipment

- Dig sedimentation pool, about 1X1 m wide and 10-20 cm deep. To catch the water as it spurts out of the drill stem, slope its sides toward the pool.
- Dig a starter hole for the bore stem, about 0.5 m deep, 10-15 cm diam, connected to the pool via a 1-2 ft canal.

- Erect 2 of the sticks half a metre behind the starter hole, half metre apart, and bridge them with a third short pole that will double as a stand for the drill operator and a fulcrum for the fourth stick (used as a handle to pulsate the drill stem).
- Tie the first short length of pipe to the handle with rope, using a slip-knot on the pipe.
- Fill water in the pool.
- Man the handle and the drill stem.
- The whole operation so far may be done in 15-20 min (provided water is readily available), and drilling can begin.
- At first the water column in the pipe is short and does not have the weight that later on will give high speed and large carrying capacity.

Boring the well

The work of two experienced operators is a rhythmic, perfect coordination – one using the handle to repeatedly jerk the drill-stem upwards in short strokes, the other using his one hand to create vacuum on top of the water column during the upstroke, thereby pulling the whole column along and accelerating it to a high speed at the end of the upstroke. At that point the water spurts out, carrying with it sand, gravel and clay from the bottom of the bore-hole. The lumps of clay thrown out are sometimes long strings filling the whole diameter of the pipe (1½" diam), and the drill stem will then rapidly sink into the ground, interrupted only briefly each time a new pipe needs to be added at top.

Performance

- a. Under suitable conditions sludging is one of the faster drilling methods; an experienced team can often sink two 12m wells/d at reasonable effort. The secrets behind such high performance are:
 - a minimum of field transport,
 - easy mounting,
 - small team (minimum 2),
 - a surprisingly high speed as the water spurts from the drill pipe, and
 - continuous sludging out of mud.
- b. Well sizes within 4-inch diam and 20 m depth are easiest to make but depths can be far greater and diam may be increased to 6 inches, usually in 2 or 3 stages.