

**DEVELOPMENT  
TECHNOLOGY  
UNIT**

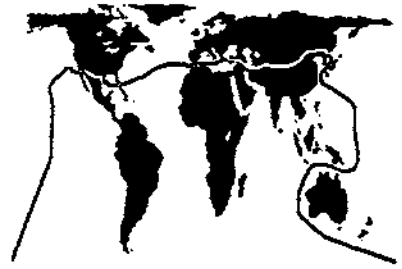

**Working Paper No. 34**

**The Treadle Pump**

**1991**

**Development Technology Unit  
Department of Engineering University of Warwick  
Coventry CV4 7AL UK**

**Tel: +44 (0)203 523523 extn 2339 Fax: (0)203 418922 Telex: 311904 UNIVWK G**

## **THE TREADLEPUMP**

**A human-powered pump for small-scale irrigation  
in Developing Countries**

**DTU Working Paper 34**

**prepared for The Ramat-Warwick Linkage Programme, Sub-Programme 4  
under the North East Arid Zone Development Programme  
Borno State, Nigeria**

**The Development Technology Unit, Department of Engineering  
University of Warwick, Coventry, CV4 7AL, U.K.**

## SUMMARY

Using a treadle pump to lift water to a height of 5 metres it is possible for a farmer to irrigate approximately 0.25 hectares of land. The pump can be used for long periods of time because of good ergonomic design. The cost of construction is low and the pump can provide an appropriate technology for smallholders with little capital to spend on irrigation.

# THE TREADLEPUMP

## A human-powered pump for small-scale irrigation in Developing Countries

	page
<b>SUMMARY</b>	
1.0 INTRODUCTION	1
2.0 THE NEED FOR TREADLEPUMPS- A comparison of pumping technologies for small-scale irrigation	2
3.0 TREADLEPUMPS- A description	3
3.1 Pump Cylinders	3
3.2 Pump Manifold	3
3.3 Non-return Valves	3
3.4 Piston Assembly	5
3.5 Treadles	5
3.6 Pulley Wheel	5
3.7 Frame	5
3.8 Summary of Treadle pump Components	7
4.0 THE ERGONOMICS OF TREADLEPUMPS	7
4.1 Utilising Human Power	7
4.2 Stroke Length	7
4.3 Cadence	8
4.4 Foot Force	8
4.5 Mechanical Advantage	8
4.6 Treadle Spacing	9
4.7 Summary of Ergonomic Features	9
5.0 AVAILABLE DESIGNS OF TREADLEPUMPS	10
5.1 The Bellow pump, Philippines	10
5.2 The Tapak-Tapak, Bangladesh	12
5.3 The USAID treadle pump, Ivory Coast	14
5.4 The Harare treadle pump, Zimbabwe	16
5.5 The Warwick treadle pump, (Nigeria)	18
6.0 THE WARWICK TREADLEPUMP- The need for a new design	20
6.1 Table of Specification: The Warwick Treadle pump	26
6.2 Status of the Warwick Treadle pump	27
<b>BIBLIOGRAPHY</b>	28
<b>APPENDIX A</b> Drawings of the Warwick treadle pump with construction notes	29
<b>APPENDIX B</b> The Treadle pump for North Borno State, Nigeria	32

## 1.0 INTRODUCTION

This report has been prepared by the Development Technology Unit of the University of Warwick, Coventry, U.K. It is part of the studies carried out under an EEC funded linkage programme between the University of Warwick and Ramat Polytechnic, Borno State, Nigeria. The linkage is a sub-programme of the North East Arid Zone Development Programme (NEAZDP) which itself seeks to promote the development of rural people in the region and promote long-term sustainability.

The subject of this report is treadle pumps and their use for small-scale irrigation in Developing Countries. The treadle pump is a human-powered water pump that can lift irrigation water from ground or surface sources. The pump consists of two pumping cylinders that are worked reciprocally by the action of the operator standing on two treadle bars. This system gives a near constant flow of water and a comfortable pumping action for the user. The design of the pump allows operators to shift their position along the treadles and so vary the force on the cylinders; in this way a range of pumping heads can be achieved.

The principle advantage of the treadle pump over other forms of human-powered water pump is that it makes best use of the muscles of the body: The treadle action uses the large muscles of the legs, buttocks, and back. This allows sustained use of the pump and the pumping of large volumes of water that are needed for irrigation.

There are currently several designs of treadle pump produced, and a section of the report details their principal features, strengths, and weaknesses. For interested parties there are contact addresses for all the pumps described.

The report goes on to describe why it was thought valuable to develop a new design to cater to the special needs of African countries. The result was the Warwick treadle pump and the original design specification is included with a discussion of the pump's construction and performance. Complete construction details of the Warwick treadle pump, engineering drawings and notes, are given in an appendix. A second appendix discusses the use of the treadle pump in the context of Borno State, Nigeria.

## 2.0 THE NEED FOR TREADLEPUMPS A Comparison of Pumping Technologies for Developing Countries

As the human population increases at an ever faster rate the need for increased food production is pressing. The greatest need is in Developing Countries where populations are growing fastest and the land available for the growth of staple crops is shrinking. One of the best ways this can be achieved is by making appropriate irrigation technology available to the small farmer.

In Developing Countries much of the land is family-owned in small plots. It is not uncommon for the majority of farming land to be owned in units of less than 2 hectares. These small lots are often worked solely by the owners and their families, and external inputs, in the form of mechanisation and fertiliser, are low.

The way to increased production has often been seen through incorporating small holdings into larger units and introducing mechanisation and large-scale irrigation. This approach, while successful if carefully thought out, often produces many problems that did not occur with indigenous farming methods; salination, hard-panning, and loss of fertility. Often this type of farming proves to be less efficient than traditional methods.

Modern thinking for the development of agricultural production in Developing Countries looks to retain the traditional ownership of the land and support the indigenous farmer by providing educational and appropriate technical support.

Irrigation is one of the principle ways to increase production in agriculture either by extending the growing season on existing land or by bringing further land into production. Providing small farmers with irrigation water from large schemes can be very expensive: The cost of civil engineering works must be subsidised by the government, or another agency, as the cost is beyond the reach of the rural poor. The collection of water fees from a large number of users is also difficult. Such schemes often achieve only low efficiencies (high water wastage).

The alternative is small scale irrigation using appropriate, locally maintainable technology that is directly controlled by the farmer. As a smallholder can only afford a small capital sum and low running costs the options for technological inputs are limited. A low initial cost eliminates the use of a renewable energy such as solar or wind even though these technologies offer very low costs in the long term. The cost of petrol or diesel engines is also high and although fuel is cheap in some countries, such as Nigeria, its supply can be uncertain and spare motor parts are, at best, expensive, at worst, unobtainable. This leaves the use of animal or human labour for water pumping activities. In areas where draft animals are already used animal power is a good option. However if the animal is used solely for irrigation activities it is unlikely that the extra return gained is sufficient to justify the expense of keeping the animal. In this case joint ownership would seem to be the answer but this brings with it a further set of problems regarding the upkeep of the animal.

Human labour on the other hand can be used for irrigation when not occupied with other tasks, and although the power output of a human is low, when compared to other energy sources, the farmer can decide exactly when and how much to irrigate the fields. This level of control given to the farmer can significantly increase yields.

For these reasons small, human-powered water pumps for irrigation are very useful to the smallholder with few resources. Pumps that can be operated and maintained at a village level also have the advantage reducing the dependence of farmers on outside support services and increasing their self reliance. The treadle pump is designed with these criteria in mind and as will be shown in Section 4.0 makes best use of the capabilities of the human body in providing power for water pumping.

### 3.0 TREADLEPUMPS- A Description

The treadle pump is a human-powered water pump that is used principally for irrigating smallholdings of land. In all its forms water is pumped by two direct-displacement pistons which are operated reciprocally by the walking/stepping motion of the user.

A general layout of the treadle pump is shown in Fig 3.1. The range of treadle pump designs can be split into two groups: Those that will lift water from a lower level to the height of the pump; and those that will both lift water from a lower level and lift it further to a greater height than the pump. These two types can be described as a suction pump, and a suction and pressure pump, respectively.

The basic components of any treadle pump are described below:

#### 3.1 Pump Cylinders

The two pumping cylinders are operated reciprocally and give a near continuous flow of water. Depending on the operating head, the diameter of the pump cylinders is normally between 75mm (for high heads) and 150mm (for low heads), most often 100mm diameter is chosen. A cylinder diameter of 100mm is suitable for pumping water to heads of between 3 and 8m.

Cylinder materials vary from curved steel sheet to bamboo to pvc pipe. Choice of material is strongly influenced by local availability and cost. Steel is a good choice if there are sufficient skills and machinery to work it; pvc pipe is often more readily available and easier to work. Bamboo is cheap and plentiful in some locations and has the advantage of maintainability at the farm level but suffers from having a short working life: It is not suitable for pressure pumps. The choice of material will also be influenced by the type of pump manifold and how it connects to the cylinders.

#### 3.2 Pump Manifold

The manifold connects the inlet and outlet pipes to the cylinders (in a suction pump it is not necessary). It is separated into two; water enters the pump at the entry side of the manifold, and after passing through the cylinders, leaves on the discharge side. The manifold normally houses the non-return valves which prevent backflow in the pump.

The manifold can be constructed from steel sheet welded into the form of a box, or more easily, in a pump with pvc cylinders, from pipe fittings or straight pipe. The design of the manifold must allow for the removal of the non-return valves for maintenance.

#### 3.3 Non-Return Valves

In a suction only pump the non-return valves are situated in the piston heads and in the inlet pipe. In a suction and pressure pump there are two pairs, one on the inlet side of the pump and one on the outlet. The valves allow water to travel through the pump but prevent its backflow to the source. The valves open and close due to the positive and negative pressures developed during pumping.

Various types of non-return valve are used in treadle pump designs, these include rubber flaps, swinging gates, and poppet valves. The Warwick design uses a new type of valve that relies on the stretching of a rubber flap over a pattern of holes and is unique in that it involves no moving parts.

**FIGURE 3.1 Main Components of the Treadle pump**

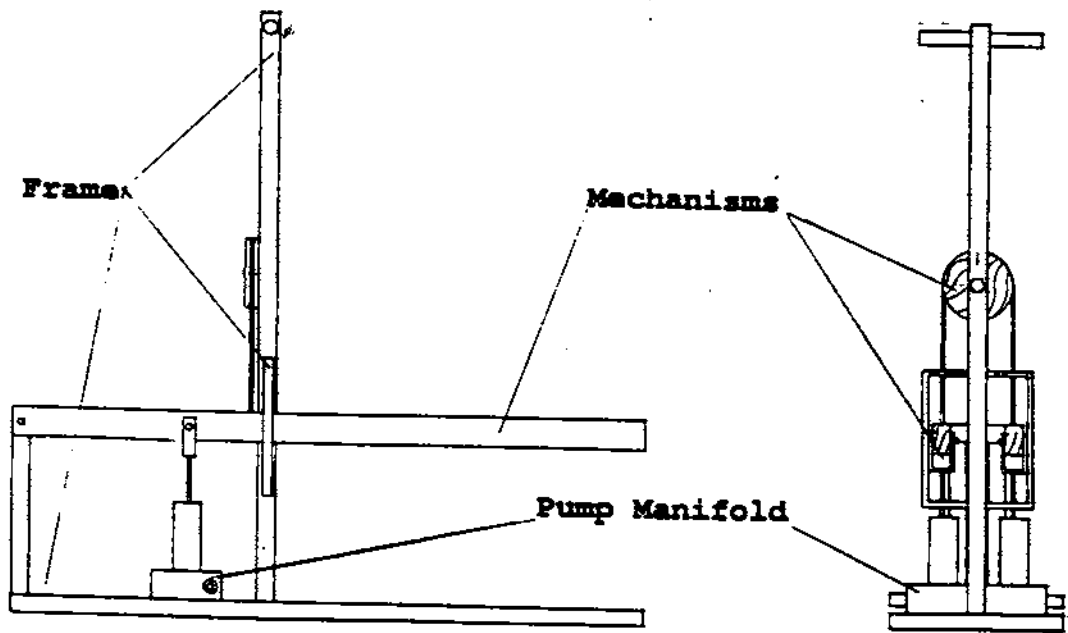



### 3.4 Piston Assembly

The pistons are driven up and down within the cylinders by the weight of the operator on the treadles. The piston rod is connected to the treadles by a hinge that allows the piston to stay vertical in the cylinder as the treadles are moved up and down. This is important to maintain a good seal between the piston cups and the cylinder.

The piston rods are normally of round steel bar and are threaded at one end to attach the piston cups or rings. The piston cups can be made of rubber or leather but must provide a good water seal and sustain the rigours of continual friction against the cylinder wall.

### 3.5 Treadles

The pump operator stands on the treadles and pushes them up and down to work the pump. They are normally hinged at one end but in one bamboo version the hinge is between the cylinders and the operator. At the opposite end, the treadles are supported by a pulley wheel and rope or a rocking bar. The range of movement is dictated by the stroke length of the pistons and most importantly by the comfortable operating step of the operator.

The treadles can be made from wood, bamboo, or steel. Steel is only normally used when the treadles are to be cranked to bring the operator closer to the ground.

### 3.6 Pulley Wheel

The pulley wheel allows the cylinders to move reciprocally and so provides a natural operating style for the user. The wheel has a central axle mounted to a frame; a simple axle, such as a 16mm diameter bolt, is normally used. The wheel can be made from hard wood and boiling the wheel in oil treats the wood and lubricates the bearing for a substantial time.

An alternative to the wheel is a rocking bar which is pivoted in the middle. This arrangement is harder to balance but may be easier to construct in some instances.

### 3.7 Frame

The component parts of the treadle pump are mounted on a frame or in some designs buried in the ground. A frame allows the pump to be carried to where it is most needed. Although an expensive part of the pump, portability adds significantly to its value in irrigation.

Angle iron or box section are most often used to make a frame that will stand the weight of the user and the rigours of transportation.

If the pump does not need to be moved regularly it may be acceptable to dispense with the frame and support the treadle hinges and the pulley wheel on stakes knocked into the ground. This will reduce the cost of the pump. In Bangladesh the Tapak-Tapak pump uses this set-up but it is reported that the pump is carried back to the house each night for security; obviously here the lack of a frame has not stopped the pump being portable!

### 3.8 Summary of Treadle pump Components

If the parts just described are well designed and matched, the pump will operate smoothly and efficiently. To end this section here is an attempt to describe the action of powering the treadle pump.

The motion of the operator's legs on the treadles is similar to a combination of walking on the spot and of climbing a ladder. Operators can become accustomed to this movement very quickly and in a well designed pump will find that it can be sustained for several hours a day with appropriate rests. A full description of the ergonomic design of the pump is given in Section 4.0.

## 4.0 THE ERGONOMICS OF TREADLEPUMPS

Using human labour to power a water pump has several advantages: Given a constant water source the farmer can choose exactly when to irrigate. If irrigation is not required the farmer can usefully work at other tasks without having expensive animals or machinery standing idle. However the human body is not very efficient at converting food stuffs into work energy and requires what is, in effect, very high-grade fuel. Also the total amount of power available from one person for manual work is not high- it is in the range 200-300 watts per day. So any machine that uses human power should be efficient to make best use of the scant power available. Another important point is the ergonomic design of the machine that enables it to be used comfortably and for sustained periods of time.

The human body will quickly tire if isolated groups of muscles are used exclusively or if the body is forced to work in an awkward position. Where only a small power input, in human terms, is required, for short periods of time, these points do not need to be considered so carefully. A good example of this is the community handpump where the work done by each individual user is small: The arms are required to do almost all the work, and often the body is bent over, but the water is soon lifted and the activity ceases.

But for irrigation the volumes of water that are necessary to irrigate even small areas of land (0.25 hectare) are very large- several thousand litres when compared to 50-100 litres for household use- and consequently the pump design is paramount. Therefore the human-powered, small-scale irrigation pump must be able to pump large quantities of water and be comfortable to use for several hours a day.

### 4.1 Utilising Human Power

Perhaps the best way for utilising human power is the bicycle: The pedalling motion of the legs uses the large muscles of the legs, buttocks, and back. A power output of approximately 75 Watts can be sustained for up to 4 hours a day. However the bicycle design requires the use of sprockets and chains which are costly to produce and cannot be easily repaired in rural areas of Developing Countries.

A much simpler arrangement that approximates to the action of pedalling is that used in the treadlepump. The operator stands with one foot on each treadle bar and operates the pump by moving the bars up and down in a reciprocating motion. This is a natural movement for the human body, somewhat akin to walking, and can be sustained for long periods if the parameters of stroke length, cadence, and foot force are matched to the operator.

### 4.2 Stroke Length

The stroke length is the vertical distance between the feet when one foot is at its uppermost position and the other at its lowest. Too short a stroke and the leg muscles will tire quickly, too high and the leg muscles are straining. On a bicycle a crank of approximately 170mm gives a comfortable and efficient action; this is equivalent to a stroke length of 340mm on a treadlepump. In the case of the stepping action of the treadlepump this is a long stroke and results in a low pumping cadence (the speed of pumping). The relationship between stroke and the cadence is inversely proportional: The stroke length is governed by what is a comfortable speed to operate the pump. Another point to consider is the difficulty of sustaining a high foot force when pumping to high heads if the stroke length is long.

Bearing in mind these factors a pump that offers stroke lengths in the range of 100-350mm will be comfortable to operate. The operator will normally choose a short stroke length at high heads and a longer stroke with decreasing head.

### 4.3 Cadence

The cadence is the frequency with which the treadles are moved up and down: One cycle is completed when a treadle bar is pushed down and rises once again to its starting position. A cadence of up to 60 cycles per a minute is comfortable.

With increasing foot force (at higher heads) the cadence will tend to drop and the stroke length increase. The opposite is true for low heads where the stroke can be very short and fast; this can be tiring. In this case moving along the treadles nearer to the hinge will reduce the mechanical advantage and so improve the pumping action of the operator.

### 4.4 Foot Force

The pumping head is overcome by the force on the piston acting against the water in the cylinders. The piston force must also overcome the friction losses in the pipes.

The force exerted on the pistons by the operator can be varied by the operator moving along the treadles: This varies the mechanical advantage between the operator and the cylinders. This is one of the most useful features of the treadle pump. Not only can the operator find a comfortable position for different pumping situations but also the pump is adaptable, without modification, to a wide range of people of different strengths and weights.

For extended periods of pumping the foot force should not exceed 50% of the operator's body weight, the maximum for short periods of time is approximately 70%. Therefore to be suitable for men, women, and children a pump should be designed to give foot forces of 15-50kg across the range of pumping heads.

If a pump is to be used almost exclusively for a particular head application then the cylinder diameter can be chosen to obtain suitable foot forces. The most common cylinder diameter is 100mm and is suitable for heads of between 3-8 metres. Below 3m a 150mm cylinder is suitable and above 8m a 75mm can be used. However a 75mm cylinder reduces the quantities of water pumped significantly and therefore pumping irrigation water to heads of more than 8 metres using human power is not normally economic.

### 4.5 Mechanical Advantage

Moving up and down the treadles varies the mechanical advantage of the treadle pump. In this way the operator can vary the force exerted on the pistons while maintaining an approximately steady foot force. This is much less tiring than a pump where the force required is fixed according to the head of water.

To allow the pump to be used by the widest range of operators and across varying pumping heads it can be calculated that the mechanical advantage must vary between 0.5 to 1 and 3 to 1 for a 100mm cylinder. The low values of mechanical advantage, less than 1 to 1, can be easily obtained by the pump operator moving on top of the pistons and even past them, next to the hinges. For high mechanical advantage, of 3 to 1, the distance between the hinge and the end of the treadles must be three times the distance between the hinge and the piston. Care must be taken to ensure the pump does not overturn when the operator stands at the extreme end of the treadles.

#### 4.6 Treadle Spacing

A comfortable spacing of the treadles is between 175-200mm. Slight variations can be achieved by the operator moving the feet to one side of the treadle bars. In practise the spacing of the cylinders will probably dictate that the treadle spacing is close to 200mm.

#### 4.7 Summary of Ergonomic Features

A pump that provides the maximum range of adaptability while retaining a comfortable pumping action will have the following features:

Stroke Length	100-350mm
Cadence	as chosen by operator
Foot Force	15-50kg
Mechanical Advantage	from 0.5 to 1 upto 3 to 1
Treadle Spacing	175-200mm

## 5.0 CURRENT TREADLEPUMP DESIGNS

### 5.1 The Bellow Pump

The Bellow Pump design evolved at the International Rice Research Institute (IRRI) in the Philippines. However although having some characteristics in common it is not a true treadle pump and so only a brief description is given here. The pump has two sets of flap valves and is both a suction and pressure pump.

#### Construction

The pump utilises a pair of flexible bellows fitted together on a base plate; see Figure 5.1 for a general layout. The pumping action is a rocking one with the bellows being operated reciprocally. The material for the bellows is principally canvas which is reinforced with steel sheet with a rubber bladder inside. The bellows are stitched together to achieve the desired shape and considerable care is needed to ensure a water-tight seal. The discharge box, a kind of manifold, is made from steel sheet folded into shape. The non-return valves are a rubber flap with a hard rubber stiffener; the valve assembly bolts over a hole in the discharge box.

In general the construction requires accurate marking out of the component parts and skillful stitching to produce a durable pump. However few machine tools are needed; there is a small amount of welding. The materials used are many: steel, canvas, two types of rubber, bolts, rivets, steel and plastic pipe.

#### Performance

The output flow of the bellow pump is large by human-powered pumping standards- nearly 90 l/s at 1.5m head falling to 40 l/s at 3.5m head. The pump testing was carried out by pumping for 15 minute periods and so even the quoted maximum efficiency figure of 40% at 2.5m, calculated using a human power input of 75 Watts, could be over optimistic. Pumping to heads of greater than 3.5m is not suitable since the foot force the operator must apply is excessive; unlike a treadle pump there is no way to vary the mechanical advantage of the bellow pump.

#### Summary

The Bellow Pump requires considerable skill in its manufacture although few tools are required. It can pump large volumes of water to small heads but is, at best, only 40% efficient. Reports of field trials call into question the durability of the pump and it appears that, now, few are still used or manufactured.

Further details from:

International Rice Research Institute  
P.O. Box 933  
Manila  
Philippines

FIGURE 5.1 The Bellow Pump

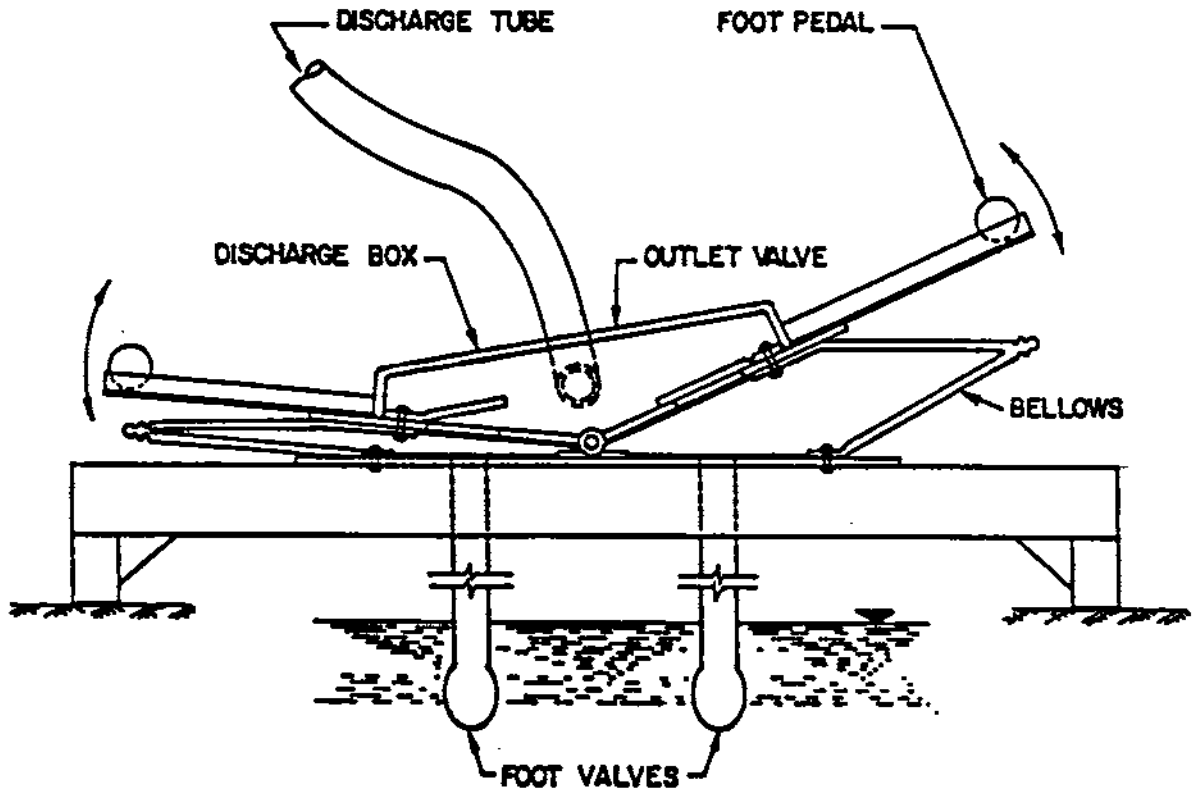

**MANUALLY OPERATED BELLOW PUMP  
FOR RURAL COMMUNITY WATER SUPPLY**

## 5.2 The Tapak-Tapak, Bangladesh

The Tapak-Tapak Treadle pump, or TT Pump, is almost certainly the most widely used of treadle pump designs. The design originates from northern Bangladesh, where there are reported to be 50,000 pumps in use, and has also been adapted by IRRI for use in the Philippines.

The pump is for suction only and so is suitable only for pumping from shallow wells (upto a maximum 7m, but more normally 5m) or from surface water. In Bangladesh this is ideal since the water table is close to the surface even in the dry season.

### Construction

The original version of the TT Pump was made predominantly of bamboo which kept its cost very low- US\$8 in 1986. Modifications to the pump have used sheet steel and even cast iron cylinders. A layout of the TT pump as built in the Philippines is shown in Figure 5.2

Water is sucked up to the pump manifold and through non-return valves into the cylinders. The valves are simple flaps of car tyre. The cylinder material is bamboo or a more durable material in the improved pumps. The piston heads contain bucket valves that allow water to flow through the piston on the downstroke and drain into a channel that carries the water to the field. The bucket valves use prefabricated piston cups that are made for handpumps; these are commonly available in some countries but can be very expensive in Africa.

The layout of the pump is typical of treadle pumps in general: The treadles are supported at one end by a rotating hinge and the cylinders are placed approximately 1m from the hinge to avoid excessive twisting of the piston cups in the cylinder. The operator stands at the far end of the treadles next to the pulley wheel that supports the treadles. In the Bangladeshi "Dheki" design this has been modified to eliminate the pulley wheel and supporting rope: The hinge has been placed between the operator and the cylinders. This arrangement has several ergonomic disadvantages but the cost savings appear to override these as the design is now the best seller. The frame and the pipe work for the original TT pump are very cheap since they are all made from bamboo by the farmer.

In the improved version of the pump developed in the Philippines the construction is much more complicated: Part of the frame is welded steel and the cylinder unit is of intricately folded sheet steel; the piston bucket valves need some machining; steel pipe is used for the suction pipe. This increased the cost of the pump to US\$25 in 1987 but the pump is a very good product. However the materials and skills used in the construction of this pump are prohibitively expensive in some countries, many parts of Africa especially.

### Performance

The figures available for the TT pump suggest that efficiency is quite high. At low rates of exertion the water power delivered by the pump is in the range of 40-50 Watts for lifts of between 3.4-5.5m. From this an estimate of the pump efficiency is approximately 50%. Surprisingly the results for the modified or "Dheki" design of pump show only a slight reduction in efficiency even though the pumping action and mechanical advantage are poor. This could possibly be due to the operators familiarity with the "Dheki" as the same mechanism is used in rice pounding devices.

As the pump is suction only it is unlikely that it is suitable for use where water is at a depth of more than 5m; below this the quantity of water required for irrigation is very hard to pump using human power.



FIGURE 5.2 The Tapak-Tapak Pump

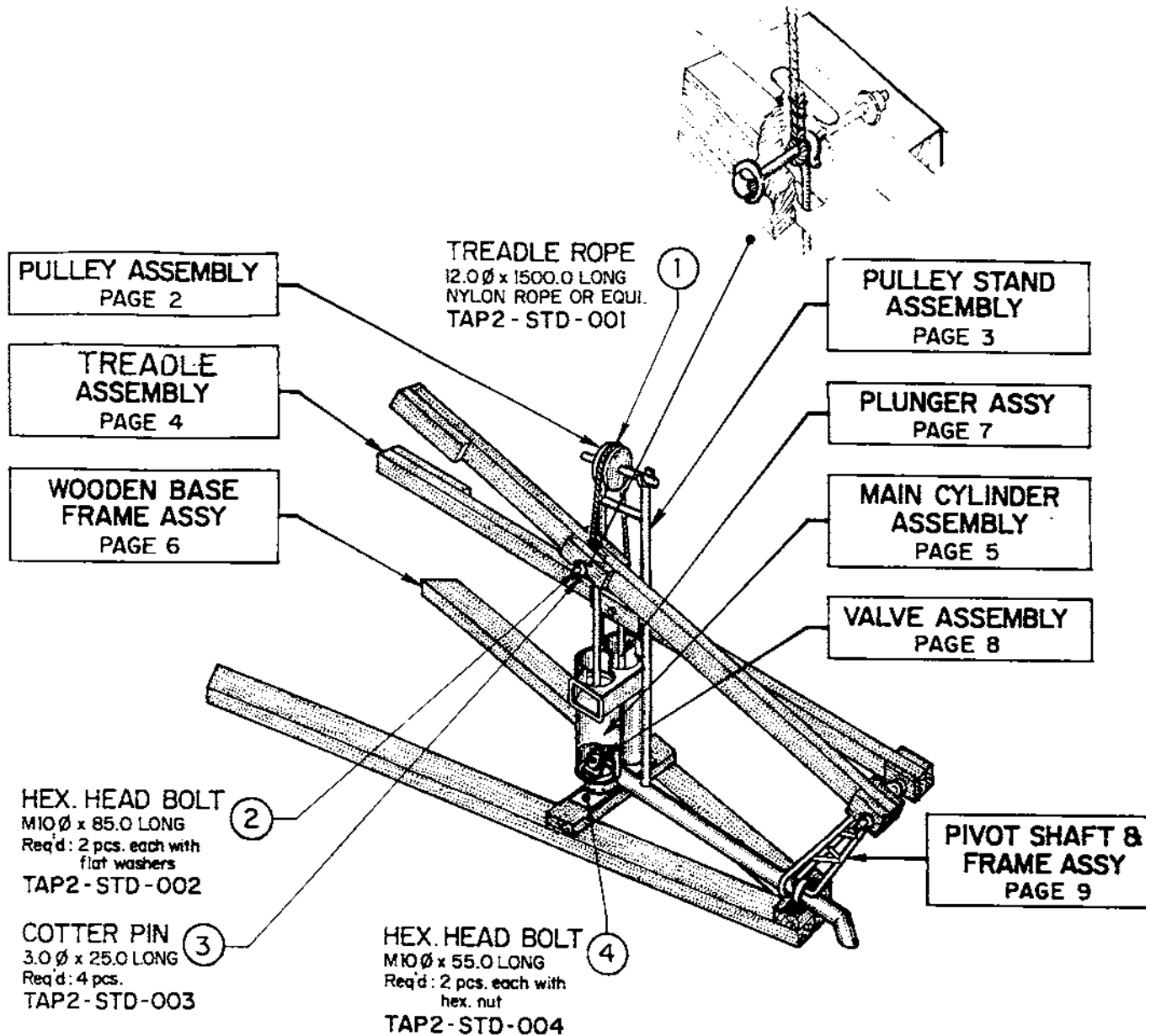

**NOTE:** DETAILED PARTS IN THE FOLLOWING PAGES ARE SERIALIZED BY REFERENCE NUMBERS AND ARE ENCLOSED IN HEXAGONAL FIGURE  $\hexagon$  TO INDICATE FABRICATED PARTS. THOSE ENCIRCLED  $\circ$  DENOTES PURCHASED STANDARD PARTS.

**PERSPECTIVE VIEW**

## Summary

The Tapak-Tapak Pump is the most widely used treadle pump and is suitable for pumping from wells and surface water where the lift is less than 5m. Construction can be very cheap if bamboo is used for the principal parts but the introduction of more durable materials and commercial piston rings increases the cost. Increased levels of skill are required to make the improved versions.

Further details from:

RDRS  
GPO Box 618  
Ramna-Dhaka 1000  
Bangladesh

and,  
International Rice Research Unit  
P.O.Box 933  
Manila  
Philippines

### 5.3 The USAID treadle pump, Ivory Coast

The USAID treadle pump is another design based on the Tapak-Tapak Pump (TT Pump) from Bangladesh. The design has been adapted to use commercially available pvc pipe and fittings. There are also two versions of the pump; suction only, and suction and pressure.

#### Construction

The design is shown in Figure 5.3. It has no frame and is buried in the ground on site. This is a disadvantage if the pump is to be moved frequently. The treadles and pulley wheel are similar to the TT Pump but the cylinders and the manifolds are made from pvc pipe and pipe fittings. The manifolds contain the non-return valves and so are fixed together using a non-hardening joint compound to allow for removal during maintenance. This compound might be difficult and expensive to obtain. There are two designs of non-return valve offered for the pump, a simple rubber swinging gate valve or a more complex flap valve that closes over a metal disk perforated with drill holes. Both systems require some machining to obtain a good fit with the inside of the pipe. A suction only version uses valves in the piston cup and it too requires machining.

The use of pvc fittings and pipe makes the manifold and cylinder assembly extremely easy to construct. However in many countries fittings such as the T-pieces and elbows required are both difficult and expensive to obtain. The piston cups are also commercial products although leather could be substituted.

#### Performance

The pumps were tested over 15-30 minute intervals and so using a human power output figure of 75 Watts maybe misleading: For short periods such as these a fit person can sustain a higher power rating. Even so the figures give by the designers of approximately 1.5 l/s at 6m head and 2 l/s at 4m head indicate that efficiency of the pump must be quite high- perhaps 75% This is not so surprising considering the quality of materials and construction in the pump.

FIGURE 5.3 The USAID Treadle pump

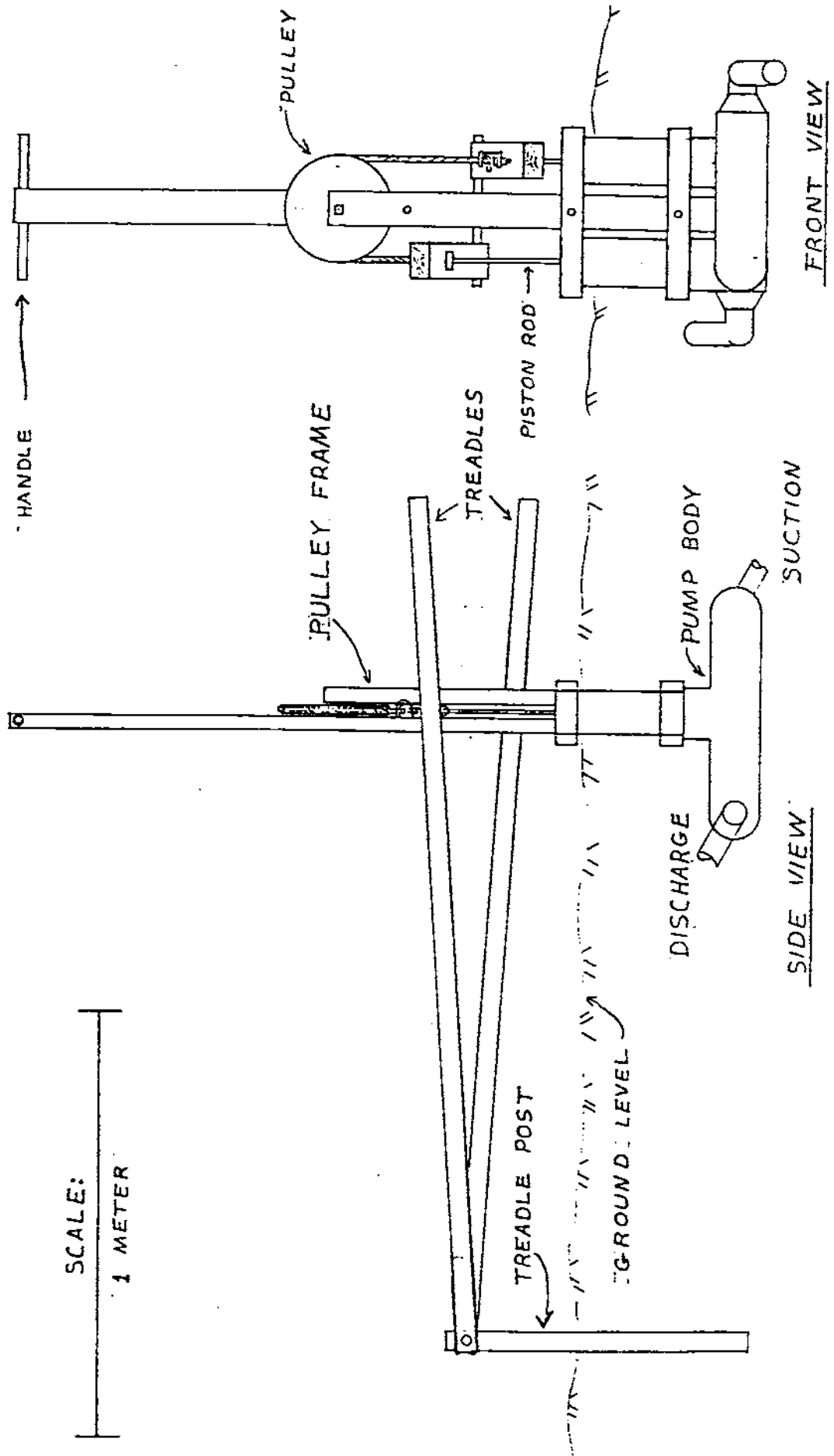

## Summary

This is a good design of pump if pvc pipe and fittings are available and there are the necessary machines and skills to construct the non-return valves. Its lack of portability might also restrict its appropriateness. The use of many bought materials will make this an expensive pump in many parts of the world.

### 5.4 The Harare treadlepump, Zimbabwe

This pump has been designed with the aid of Loughborough University in the U.K. and has been called the Harare treadlepump for the purposes of this report because that is where it is manufactured (in the Loughborough University literature it is called the Pressurised Discharge Treadle Pump). It is a suction and pressure treadlepump which has a familiar layout.

#### Construction

Like the USAID pump pvc pipe is used for the cylinders but the manifold is made from welded sheet steel. Access to the manifold is via a cover plate that bolts to a flange plate in the manifold. Internally the manifold is divided in two to provide a separate valve chamber for each cylinder. The non-return valves are of a novel design that allows the whole valve assembly to be removed for maintenance: The valve is not attached to the manifold but is restrained from "popping out" by a stop of thick car tyre. Diagrams of the manifold and the valve design are given Figure 5.4.

The frame is of welded angle iron and allows the pump to be transported easily. The treadles are supported by a pulley wheel and rope and the frame includes an adjustable handle for the operator to hold.

#### Performance

Only very limited performance data is given for the Harare treadlepump; for test periods of 15 minutes the pump delivered 0.4 l/s to a head of 14m. This is a power output of 60 Watts and suggests that the operator must have been working hard. Efficiency is hard to estimate in this case.

#### Summary

The Harare treadlepump uses pvc cylinders and a steel manifold and as a suction and pressure pump can lift water to high heads. The construction requires a good deal of welding. The cost is high at US\$275 in 1989 and this is due most probably to the amount of steel and the welding involved.

FIGURE 5.4 The Harare Treadlepump

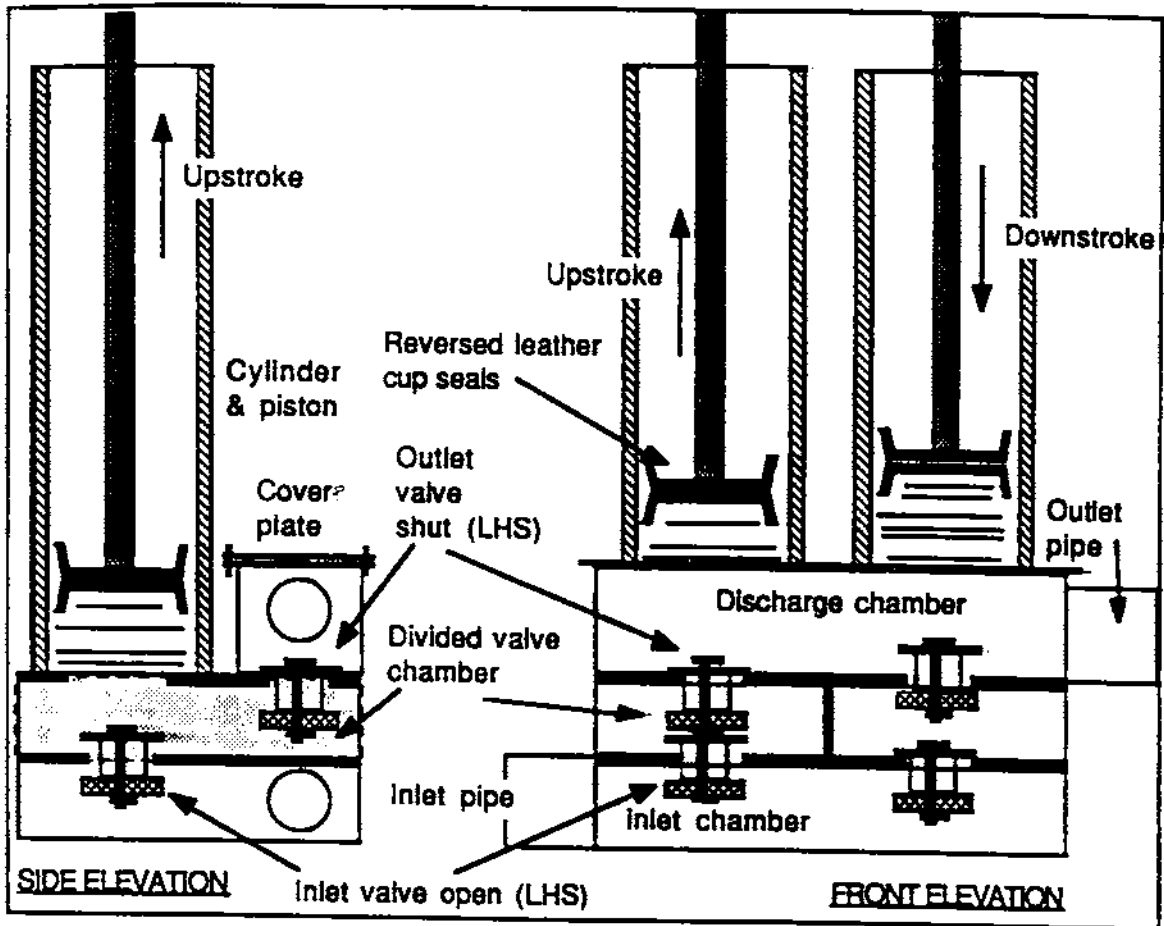

Figure 4: The pressurised discharge manifold box

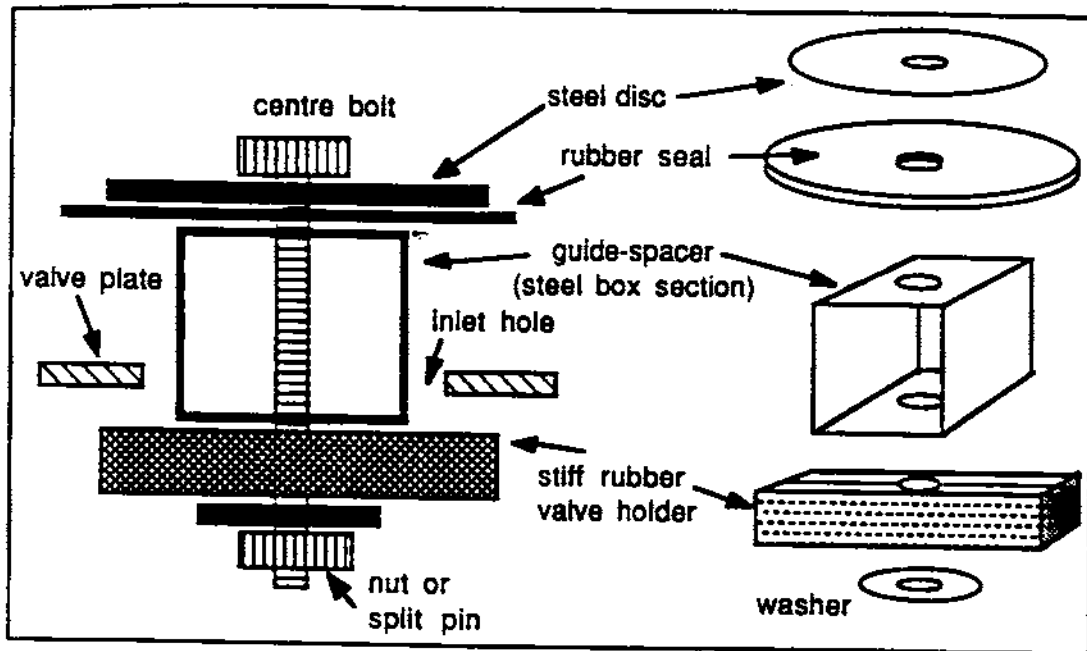

Figure 5: Valve details

## 5.5 The Warwick treadle pump, (Nigeria)

The Warwick Treadle pump is a suction and pressure treadle pump that has been designed to reduce the cost and complexity of other currently available designs particularly in African countries. At the time of writing, October 1991, it is about to undergo field trials in the North East Arid Zone of Borno State, Nigeria. A picture of the pump is shown in Figure 5.5.

### Construction

The unique feature of the Warwick treadle pump is the use of pvc pipe to form both the cylinders and the manifold. The intersection of the cylinders to the manifold is made by cutting the pipe using a metal jig: No pipe fittings are needed in its construction. The intersection is sealed with a rubber gasket which also acts as a non-return valve by stretching away from the pipe wall during pumping. As the non-return valves have no moving parts, and are made completely from rubber, they are easy to make and cheap to replace.

The pump has a frame of angle iron and treadles of wood. The piston rods are made from round steel bar and the piston cups of leather. The parts of the pump can all be made using hand tools, although the frame needs some welding and the pipe intersections must be cut using a special jig.

During assembly much care must be taken to align the valves and intersections correctly otherwise the pump will not seal properly. Dismantling the pump for maintenance is very straightforward.

The engineering drawings and construction notes of the Warwick treadle pump are presented in Appendix A of this report.

### Performance

The performance of the Warwick treadle pump is given in detail in Section 6.0

### Summary

The Warwick design of treadle pump uses straight pvc pipe and rubber flap valves to create a cylinder and manifold assembly that can be cheaply made. It is most suitable for lifts of between 3-8m. It is a design that is well suited to countries where steel prices are high and machine tools and metal working skills scarce.

FIGURE 5.5 The Warwick Treadle Pump

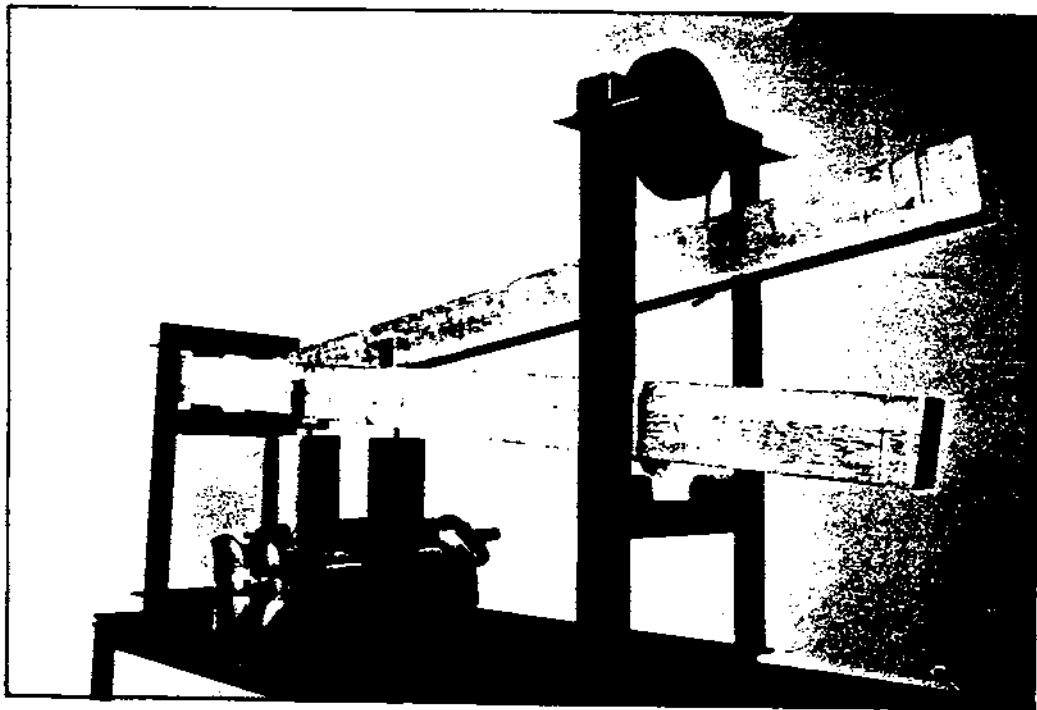

## 6.0 THE WARWICK TREADLEPUMP

Although some of the pump designs discussed in Section 5.0 have good qualities, the Development Technology Unit (DTU) at the University of Warwick felt it was worthwhile to develop a further design that:

- (a) was ergonomically effective as the best existing designs,
- (b) was well suited to the needs of African smallholder irrigation in terms of flow rate, range of heads, portability, and ease of maintenance,
- (c) was simpler to make than other designs and considerably cheaper,
- (d) used materials fairly readily available in African countries and avoids components (such as pipe fittings) which are not.

With any technology for rural application the DTU tries to serve not just the user but the artisan interest group as well- it seeks to identify products and designs suitable for income generation via manufacture in villages and small towns. Sometimes user and manufacturer interests coincide, as they appear to in this case; sometimes the user (e.g. farmer) is best served by equipment made by large-scale urban industry. The Warwick treadle pump is intended for production in small workshops with little equipment: The materials specification was determined based on the availability of materials in Zimbabwe, Zambia, and Nigeria in 1990-91. The use of scarce pipe fittings was deliberately avoided.

For reasons of simplicity and standardisation only one size of pump has been developed using a nominal 100mm diameter piston. This size is well suited to heads of 4-10m at full "adult" power but has a poor efficiency at lower heads, and hence higher flows, for which a larger diameter pump would perform better. Since the "head" supplied by the pump has to overcome friction losses in the pipes as well as lift the water, the pump is suited for lifting water in excess of 3m. At "child" power levels the optimum range of lifts is lower and the efficiency at any given head higher. The table overleaf shows the specification to which the pump was finally designed.

Figures 6.1 to 6.4 shows performance test results. These tests were undertaken in August 1991 at relatively high powers, namely those which could be sustained by a fit and healthy young man of weight 80kg for periods of 15 minutes. From Figure 6.1 it can be seen that the input power exceeded 80 Watts, giving flows higher than the specification and, in consequence, lower efficiency than the specification (the main source of inefficiency is the friction in the valves which becomes substantial at flows greater than 1 l/s). Figure 6.2 shows the effect of increasing head: Namely a fall in flow rate and a strong rise in efficiency. The rise in efficiency, combined with a slightly better ergonomic match with the test operator, explains the increase in "water watts out" with the increase in head, shown in Figure 6.1. Water Watts is a measure of the pumping power achieved.

The penalty for operating the pump in suction is shown in Figure 6.3. For example, with a total head of 5m, having all that head in suction results in a flow, 0.73 l/s, which is only 70% of the flow, 1.06 l/s, obtained when all the pump is in pressure. Thus when lifting water from a 5m high river bank, a pump close to the water level will lift significantly more than a pump situated on the bank top. It is recommended that the pump is not normally used higher than 5m above the source of the water.

In tests the pump was found to be efficient and easy to use with a number of speeds, heads, and people: The performance specification was met. However the tests were performed on a new pump; long term testing may indicate changes in efficiency over time, especially if the piston or valve wear is severe.

The materials specification was met provided pvc components are painted or well shaded to protect them from degradation by prolonged exposure to sunlight.



FIGURE 6.1

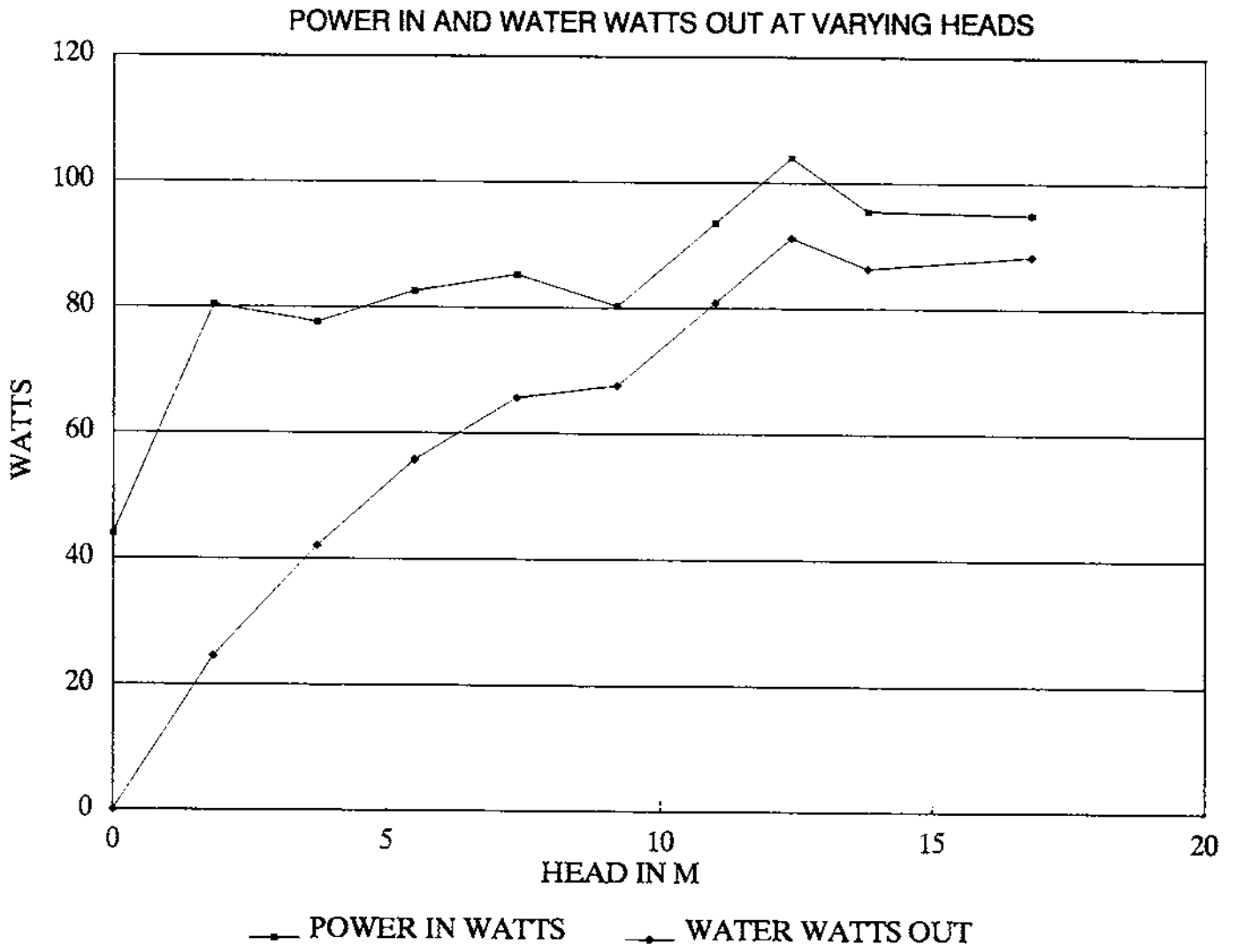

FIGURE 6.2

# EFFICIENCY AND FLOW RATE AGAINST HEAD

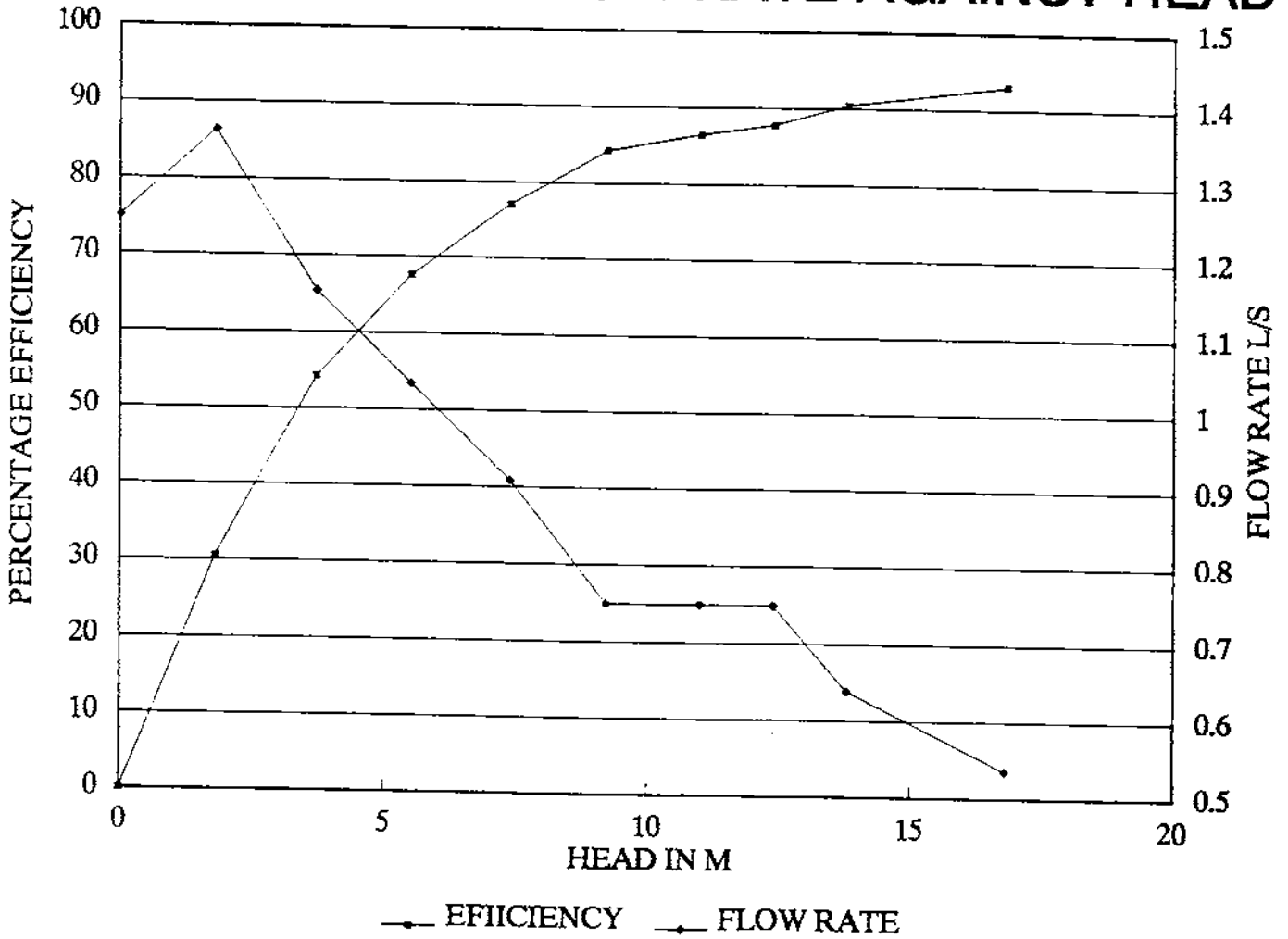

FIGURE 6.3

## HEAD VERSUS FLOW RATE

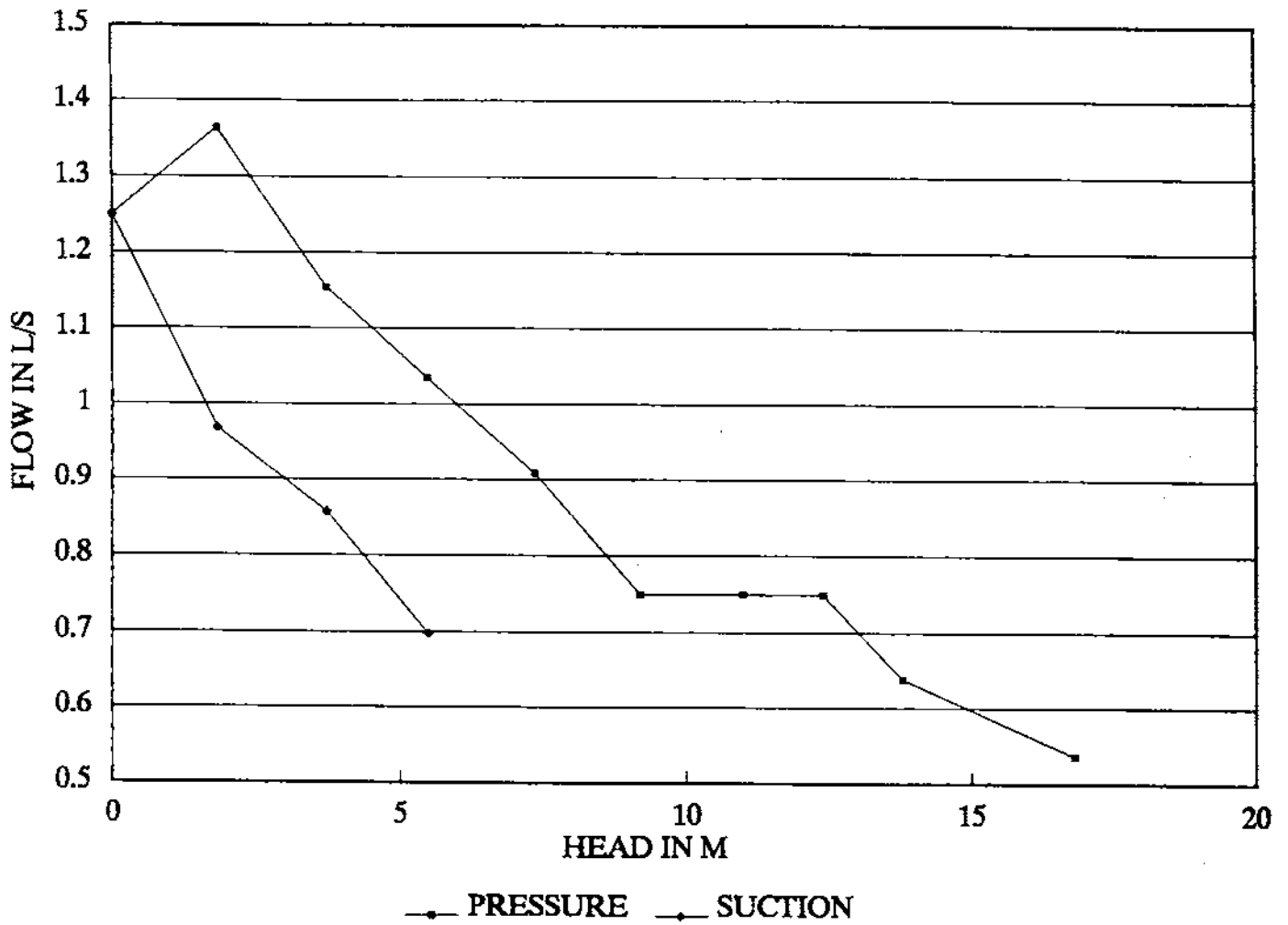
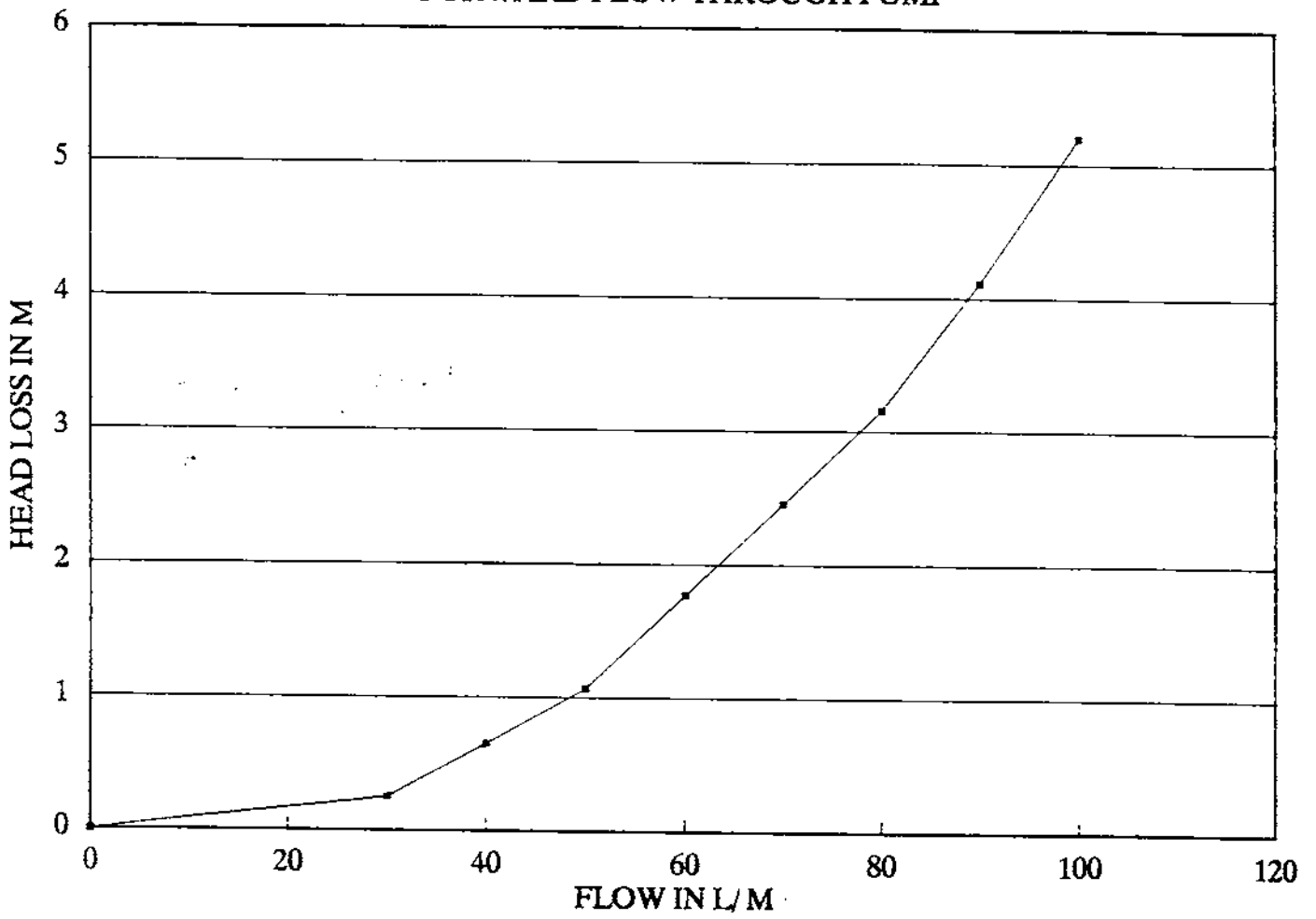

FIGURE 6.4

# FORCED FLOW VERSUS HEAD LOSS

## FORWARD FLOW THROUGH PUMP



The required case of manufacture was achieved in that only hand tools and downhand welding are required. However cutting of the manifold intersections needs to be quite accurate, within 1mm, and is best is achieved using a purpose-made jig. The production of the jig itself requires skills higher than for the manufacture of the pump.

## 6.1 Table of Specification: The Warwick Treadlepump

### Performance Criteria

- a) *Operating Efficiency*
  - i) Normal Range 3-7m, 75% efficient
  - ii) Extended Range 1-3m and 7-10m, 50% efficient
- b) *Head Range*
  - i) Adult 1-10m
  - ii) Child 1-7m (up to 10m if two children)
- c) *Treadle Height*

The height of the treadles to be as low as possible to avoid instability
- d) *Pumping Force*
  - i) Adult 50kgf maximum
  - ii) Child 15kgf maximum
- e) *Mechanical Advantage*

A variation of between 0.5:1 to 3:1
- f) *Flow Rate*

For an adult operator producing 40W at 3m head: 1l/s

### Materials used in Manufacture

- a) Only materials fairly readily available from provincial merchants have been used.  
i.e. 50x50x5mm angle iron, 110mm OD pvc pressure pipe
- b) Resistant to degradation by moisture, weather, and ultra-violet radiation.

### Manufacture, Maintenance, and Durability

- a) The purchase cost of the pump should be less than one profits from one dry-season crop (DTU Working Paper 32)
- b) No machining
- c) Minimum fabrication
- d) Low tolerances
- e) No requirement for specialised tools
- f) The pump should be maintainable with a few common tools. Wearing parts should be locally made and should have a working life of at least one crop season. Non-replaceable components should have a service life of over five years.

## 6.2 Status of the Warwick Treadle pump

The design of the Warwick treadle pump has evolved over the course of three years, 1989-1991. The primary feature that sets it apart from other treadle pump designs is the unique manifold and cylinder joint that does away with the need for pipe fittings, such as t-pieces and elbows. The intersection of the cylinders and the manifolds also houses a stretch rubber non-return valve that has the advantage of no moving parts and simple manufacture. The rubber valve also acts as the gasket for the pipe intersections.

This valve and manifold design was perfected in a BSc dissertation by Rebecca Scott in 1989-1990 and was incorporated into a treadle pump design by Simon Lucas during 1990-1991. Following testing of the pump at the University of Warwick in the summer of 1991 design changes were made to improve the clamping arrangement that holds the pipe intersections together. A jig was also constructed to aid the manufacture of accurate pipe intersections and so reduce the possibility of the rubber gasket failing at high pumping heads.

At time of writing, October 1991, the treadle pump design is about to be constructed at Ramat Polytechnic, Borno State, Nigeria as part of the Ramat-Warwick Linkage Programme supported by the EEC and part of a large development programme in the North East Arid Zone of Borno State aimed at the development of rural areas and the increased security of rural people.

After initial testing of the pump at Ramat Polytechnic and, possibly, design changes to suit locally available materials, the treadle pump will be introduced to selected villages in the North East Arid Zone for field testing. This testing will take place with the close cooperation of village development representatives and the field staff of the development programme.

If the field trials of the treadle pump are successful training courses will be offered to local artisans in the construction of the pump. The credit facilities of the development programme will be offered to artisans wishing to start production. It is hoped that the treadle pump will provide a valuable contribution to irrigation technologies in the region and a chance for smallholders, who cannot afford more expensive pumps, to grow a dry season crop and protect main crops from drought.

## BIBLIOGRAPHY

Water Pumping Devices- A Handbook for users and choosers  
Peter Fraenkel  
IT Publications, U.K  
1986

Bicycle Science  
Whitt and Wilson  
The MIT Press, Cambridge, Mass., USA  
1974

The Bellow Pump  
anon  
International Rice Research Institute, Los Baños, Laguna, Philippines

Human-Powered Pump for Low-Lift Irrigation  
R.E.Stickney, C.Abrina, et al  
International Rice Research Institute, P.O.Box 933,  
Manila, Philippines  
June 1987

USAID Universal Treadle Pump for Human Powered Irrigation  
Dan Jenkins  
USAID/Abidjan  
December 1985

Manually Operated Irrigation Pumps  
R.A.Lambert and R.D.Faulkner  
WEDC and Civil Engineering Department,  
Loughborough University of Technology, U.K

The Warwick Treadlepump  
Simon Lucas  
Final Year thesis, BSc  
University of Warwick,  
Coventry, U.K



## APPENDIX A

### The Warwick Treadle pump Engineering Drawings and Construction Notes

#### CONSTRUCTION NOTES

##### The Frame

The frame is constructed of 50x50x5mm Angle Iron and welded at joints. The choice of angle is an economic one being the cheapest section per kg and the most widely available. A lighter frame could be made from box section if the cost is permissible.

Care should be taken in the orientation of the angle as this is critical for the fixing of some components. Holes for bolts (for bolt axles and pulley wheel) should be drilled before welding. Good welds will add considerably to the robustness of the frame.

##### The Treadles

The treadles should be made from well-seasoned soft wood and be straight along their length. The holes drilled in the treadles for the hinge and the piston rod hangers should be as accurate to the dimensions given so as little wood is removed from the treadles as possible. If treated wood is not available then the durability of the treadles can be improved by, preferably, soaking the wood in old engine oil, or painting on the oil.

##### The Pulley Wheel

The pulley wheel is to be of hard wood as locally available. After the pulley is finished it is boiled in oil for a day; this not only treats the wood but provides lubricant for the bearing. Take great care when boiling oil as there is a danger of the oil catching fire. The centre hole is 16mm and to achieve a running fit the bolt axle will need to be sanded down. Washers are used on the axle in the gap between the pulley wheel and the frame. A 50mm diameter piece of tin sheet can be used as a bearing cover for the end of the bolt; it can be held in place by a rivet drilled into the frame. This cover will stop dust entering the bearing.

##### The Cylinders and Manifolds

Once the cylinders and manifolds are cut to length the first task is to fit the end caps. This will help the pipes retain their shape during the cutting of the intersections.

The end caps are made from flattened pieces of plastic pipe. To flatten a piece of pipe cut it along its length and place it in an oven at 120°C for a few minutes. The time necessary will depend on the type of plastic pipe, so experiment. (if there is no oven the pipe can be softened in boiling oil but take care). Once the pipe is soft it can be clamped between two flat sheets and allowed to cool.

The other part of the end cap is a ring of plastic, again cut from a piece of pipe. Cut a ring of plastic 15mm long and remove a small piece from it so that it can fit just inside the cylinder pipe. This can now be glued in place in the position shown. A circular piece of plastic with a diameter equal to the internal diameter of the pipe is cut from the flat sheet and glued into place on top of the plastic ring inserted before. The end cap is then finished off by gluing another ring of plastic on top of the flat plate. Apply plenty of glue to ensure a complete seal.

On one of the end caps of each manifold pipe there is a smaller diameter pipe to allow the attachment of the inlet and outlet hoses. These fittings are made from 37.5mm diameter pipe that is belled out at one end. The belled end is fitted inside the end cap and prevents the fitting pulling out. The bell is formed by heating the small diameter pipe in the oven, and when soft, pushing the pipe over a wooden former or other suitable forming tool. The smaller diameter pipe must be glued into place in the end cap before the cap is fitted in the manifold.

The end caps are now fitted and the pipe intersections in the cylinders and the manifold must be cut. They are cut using a metal template and, to achieve an accurate finish, a metal jig. First place the pipe to be cut in the jig and mark a line along its length that will pass through the centre of the two intersections. Now place the template on the pipe and mark round where the two intersections will be cut (the template is 5mm undersize to allow for errors in cutting). Cut out the two intersections with a jig-saw or similar and place the pipe back in the jig. The intersections can be accurately finished using the pipe-shaped sanding tool.

Once all the intersections are cut the valves can be made. The valves are made from car innertube and marked using the valve template. It is important that the valves are cut so that the rubber that is used curves in the same direction when fitted in the pump as it did in the innertube. This is achieved by lining up the valves so that their short axis is along the length of the innertube.

### Piston Cups

The cups are made from leather that is approximately 5-10mm thick. It is necessary to form the cups into shape using a steel mould. The leather is soaked for a day and an oversize piece put in the base of the mould. A fly press or similar is used to force to top of the mould down into the base. Leave the mould overnight and then cut off the excess leather before removing it from the mould. The mould can then be separated and the cup removed.

The cups are fitted to the piston rod by a nut and washer each side. The washers can be made from flat plastic sheet, as the end caps, to save materials.

### Assembling the Pump

The first job when assembling the pump is to put together the cylinders and the manifolds. A lot of care is needed at this stage to line up the valves very accurately with the intersection holes. If the valves are not put in straight then the pump will blow a seal very quickly and must be dismantled once more.

Lay the manifold pipe that has two holes on a desk and place two valves in the holes. Align the valves very carefully in both directions (this is made much easier if the centre lines of the intersection holes are marked on the pipe) and then press the two cylinder pipes into place. Again align very carefully the drilled holes in the cylinder pipes with the intersection holes. You can check if the alignment is approximately right by looking into the cylinders and seeing if all the drilled holes are covered by the rubber valve. Also check that the rubber valve sticks out a little way from the intersection all the way round. If anything is looks wrong take it apart and try again- it is easier to put it right at this stage!

The next stage is to lay the other two valves in the intersection holes of the two cylinders, again taking a lot of care, and push the other manifold pipe into place. Once again the drilled holes must be perfectly central to the holes in the manifold. Now the cylinders and manifolds are together it is a good idea to hold them in place with a thick rubber band at each end.

The cylinders and manifold can now be placed in the frame and the clamping pieces fitted. Tighten the bolts evenly and be careful not to crush the pipe. Fit the pistons in the cylinders and the treadles and then attach the treadles to the frame at the hinge. Put the pulley rope over the

pulley wheel to support the treadles at the other end. Connect the inlet and outlet hoses with jubilee clips- don't get them the wrong way round! The pump is now ready for use.

At certain heads it may be necessary to prime the pump by pouring water into the top of the cylinders. Also the pistons will not seal properly until the cups are thoroughly soaked. After a few strokes the pump should fill with water and the operator can find a comfortable position on the treadles.

## APPENDIX B

### Treadle pumps for North Borno State, Nigeria

The North East Arid Zone Development Programme (NEAZDP) concerns the northern part of Borno State in Nigeria. The area straddles the Sudan Savannah and Sahel climatic zones having both open savannah and stabilised sand dunes. It is crossed by rivers whose winter flow is slight but whose flow during the summer rains creates extensive swamp lands and permits basin (fadama) irrigation. The basic crops away from "fadama" lands are sorghum, millet, and dates. The nomadic Fulani fraction of the population move large herds of oxen, goats, and camels through the area. The population of the region is in excess of one million.

Water lifting in the Zone can be divided into: (a) The raising of water from village wells for domestic needs and livestock; (b) Lifting irrigation water from streams, swamps and (in the oases) shallow wells; (c) Pumping into urban water supply systems.

Treadle pumps are non-motorised and therefore unsuitable for pumping tasks requiring powers above 250 Watt-hours per day or 100 Watts over short periods. Moreover petrol and diesel fuels are extremely cheap in Nigeria and although engine-driven pumps are not cheap, they are readily available. For these two reasons treadle pumps are unsuitable for the last application listed above or for any large scale irrigation.

For normal village wells, treadle pumps have three disadvantages over handpumps or rope-and-bucket. Firstly the wells are normally deeper than the 6 metres any surface-mounted pump can efficiently draw up from: treadle pumps are only able to operate at ground level. Secondly treadle pumps do not have the proven robustness that one would look for in selecting any pump that is to be used by many different people. Thirdly the physical method of working a treadle pump- somewhat akin to cycling- may be culturally unacceptable for women in North Borno in places as public as a village well. Of these three disadvantages, the second and third may be perhaps overcome or accepted, given the much greater efficiency of treadle pumping over arm-powered pumping. The first disadvantage is more fundamental and rules out use of treadles at most village wells in the Arid Zone since they are over 6 metres deep.

It is primarily for low-lift irrigation of small plots that treadle pumps may find application in the Zone. For this activity both adequate output and low capital cost are required.

Treadle pumps can deliver (for a given human effort) nearly twice as much water as handpumps and three times as much as rope-and-bucket methods; except at lifts of less than 2 metres. Treadle pumps are likely to be more efficient than all other human-powered water-lifting devices. Even the smallest engine-driven pumpset has an output greater than 10 treadle pumps; however for small scale irrigation this high capacity of motorised pumps cannot be made use of. Worked for 4 hours a day and lifting water 3 metres, for example, a treadle pump will irrigate about 0.4 hectares and a motorised pump at least 5 hectares. The latter figure is much larger than one family could intensively cultivate using manual methods, so motorised irrigation implies either mechanical agriculture or multi-family cooperation.

Treadle pumps have a running cost that is lower than that of handpumps or buckets but higher (in Nigeria, because of low fuel costs) than that of motorised pumps. In capital cost, the treadle pump is dearer than the handpump and (for small scale irrigation) much cheaper than the motorised pump. For peasant scale irrigation, the form as well as the size of the costs is often important: Family labour costs may be more easily borne than external money costs. There are other important considerations in pump selection besides running and capital costs- availability in the market, maintainability and portability are examples.

Treadle pumps have two potential niches in irrigated agriculture in the Arid Zone. They might replace existing, less efficient, manual devices. They might open to irrigation new lands for which the capital costs and complexity of motorised irrigation are unacceptably high. As no treadle pumps are at present in use in North Borno or apparently on sale in Nigeria, it is timely to access which, if any, of the designs available world-wide it might be worth introducing. Introduction is taken to mean selection, demonstration, acceptance by users, and establishment of local manufacture.