



# Installation and Host Support Guide for AIX, HP-UX, Solaris, and Linux on POWER





# Installation and Host Support Guide for AIX, HP-UX, Solaris, and Linux on POWER

**Note:**

Before using this information and the product it supports, read the information in “Notices” on page 263.

**First Edition (January 2008)**

**© Copyright International Business Machines Corporation 2004, 2006, 2007. All rights reserved.**

US Government Users Restricted Rights – Use, duplication or disclosure restricted by GSA ADP Schedule Contract with IBM Corp.

---

# Contents

<b>Figures</b> . . . . .	ix
<b>Tables</b> . . . . .	xi
<b>About this document</b> . . . . .	xiii
Who should read this document . . . . .	xiii
DS4000 Storage Subsystem installation tasks - General overview . . . . .	xiii
How this document is organized . . . . .	xviii
Notices used in this document . . . . .	xix
Getting information, help, and service . . . . .	xix
Before you call . . . . .	xix
Using the documentation . . . . .	xx
Finding DS4000 readme files . . . . .	xx
Web sites . . . . .	xx
Software service and support . . . . .	xxii
Hardware service and support . . . . .	xxii
Fire suppression systems . . . . .	xxii
How to send your comments . . . . .	xxii
<b>Chapter 1. Overview and introduction</b> . . . . .	1
Overview . . . . .	1
The DS4000 Storage Manager . . . . .	1
Introduction . . . . .	3
The DS4000 Storage Manager software . . . . .	3
Storage subsystem management methods . . . . .	8
Setting up IP addresses for DS4000 storage controllers . . . . .	13
DS4000 Storage Manager performance planning . . . . .	14
DS4000 Storage Manager premium features . . . . .	16
DS4000 hardware and firmware requirements for AIX, HP-UX, Solaris, and Linux on POWER . . . . .	20
Finding the Storage Manager readme files online . . . . .	24
<b>Chapter 2. Installing and configuring storage management software on AIX host systems</b> . . . . .	27
Hardware, software and host system requirements. . . . .	27
AIX system requirements . . . . .	27
AIX restrictions . . . . .	28
Installing DS4000 Storage Manager . . . . .	29
Preparing for software installation . . . . .	29
Failover drivers . . . . .	30
Installing Storage Manager using the installation wizard . . . . .	30
Installing Storage Manager packages manually . . . . .	31
SAN boot with AIX . . . . .	34
Assumptions. . . . .	34
Preparing for the SAN boot procedure . . . . .	34
Steps for performing the SAN boot procedure . . . . .	34
Configuring storage subsystems . . . . .	35
Adding storage subsystems to SMclient. . . . .	35
Upgrading controller firmware and NVSRAM . . . . .	36
Creating storage partitions. . . . .	40
Storage partitioning overview. . . . .	40
Steps for defining an AIX host group . . . . .	41
Steps for defining the host and host port . . . . .	41

Steps for verifying that the host ports match the host . . . . .	42
Mapping LUNs to a storage partition . . . . .	43
Creating direct and SAN-attached configurations . . . . .	44
Creating a direct-attached configuration . . . . .	44
Creating a SAN-attached configuration . . . . .	45
Installing the RDAC failover driver . . . . .	45
Prerequisites . . . . .	45
Installing the RDAC driver . . . . .	46
Identifying devices on AIX hosts . . . . .	47
Performing initial device discovery . . . . .	48
Verifying the installation and configuration . . . . .	50
Identifying the controller ID numbers . . . . .	50
Identifying device names and bus numbers . . . . .	51
Identifying logical drives by operating system device names . . . . .	57
Identifying FlashCopy logical drive types . . . . .	59
Viewing and setting Object Data Manager (ODM) attributes . . . . .	60
Attribute definitions . . . . .	60
Using the lsattr command to view ODM attributes . . . . .	67
Additional AIX configuration information . . . . .	68
Disabling DS4000 cache mirroring . . . . .	68
Using fast I/O failure for fibre channel devices . . . . .	69
Using dynamic tracking of fibre channel devices . . . . .	70
Using dynamic capacity expansion and dynamic volume expansion . . . . .	70
Replacing hot swap HBAs . . . . .	72
Requirements . . . . .	72
Known issues and restrictions . . . . .	72
Preparing for the HBA hot swap . . . . .	73
Replacing the hot swap HBA . . . . .	76
Mapping the new WWPN to the DS4000 storage subsystem . . . . .	77
Completing the HBA hot swap procedure . . . . .	77
Resolving disk array errors . . . . .	79
Redistributing logical drives in case of failure . . . . .	81
<b>Chapter 3. Installing and configuring storage management software on</b>	
<b>HP-UX host systems . . . . .</b>	<b>83</b>
HP-UX system requirements . . . . .	83
Hardware requirements . . . . .	83
Software requirements . . . . .	83
Installing DS4000 Storage Manager . . . . .	84
Installing Storage Manager using the installation wizard . . . . .	85
Installing Storage Manager packages manually . . . . .	86
Configuring storage subsystems . . . . .	90
Adding storage subsystems to SMclient . . . . .	90
Upgrading controller firmware and NVSRAM . . . . .	91
Creating storage partitions . . . . .	95
Storage partitioning overview . . . . .	95
Steps for defining an HP-UX host group . . . . .	95
Steps for defining the host and host port . . . . .	96
Mapping LUNs to a storage partition . . . . .	97
Creating direct-attached and SAN-attached configurations . . . . .	99
Creating a direct-attached configuration . . . . .	99
Creating a SAN-attached configuration . . . . .	99
Enabling multipath I/O with PV-links . . . . .	100
Using PV-links: Method 1 . . . . .	100
Using PV-links: Method 2 . . . . .	102
Redistributing logical drives in case of failure . . . . .	105

<b>Chapter 4. Installing and configuring storage management software on Solaris host systems</b>	
<b>Solaris host systems</b>	107
Solaris system requirements	107
Hardware requirements	107
Software requirements	107
Installing DS4000 Storage Manager	108
Installing Storage Manager using the installation wizard	108
Installing Storage Manager packages manually	109
Configuring storage subsystems	115
Adding storage subsystems to SMclient	115
Upgrading controller firmware and NVSRAM	115
Creating storage partitions	119
Storage partitioning overview	119
Steps for defining a Solaris host group	120
Steps for defining the host and host port	120
Mapping LUNs to a storage partition	121
Creating direct-attached and SAN-attached configurations	123
Creating a direct-attached configuration	123
Creating a SAN-attached configuration	123
Configuring the host bus adapter cards	123
Installing the JNI adapter driver package	124
Modifying the HBA settings and binding the HBAs	125
Changing the Emulex configuration files	132
Installing the QLogic adapter driver package	132
Verifying the HBA installation	133
Modifying the QLogic HBA settings	134
Installing a failover driver on Solaris	134
Enabling the MPxIO failover driver	135
Installing the RDAC failover driver	142
Installing the DMP failover driver	144
Verifying external storage	148
Redistributing logical drives in case of failure	149
<b>Chapter 5. Installing and configuring storage management software on POWER-based Linux host systems</b>	
<b>POWER-based Linux host systems</b>	151
Host operating system requirements	151
SUSE Enterprise Linux Server system requirements	151
Red Hat Enterprise Linux 4 (RHEL 4) system requirements	153
Linux host restrictions	153
Direct-attached and SAN-attached configurations	155
Creating a direct-attached configuration	155
Creating a SAN-attached configuration	155
Before Storage Manager installation: Configuring the host	156
Configuring the SLES host	156
Configuring the RHEL 4 host	160
Storage Manager installation and configuration	162
Requirements	163
Installing DS4000 Storage Manager and utilities	164
Configuring storage subsystems using DS4000 Storage Manager	168
Failover drivers	175
After Storage Manager installation: Completing the host configuration	175
Installing the RDAC Multipath driver	175
Performing initial device identification	177
Performing common maintenance tasks	181
Checking LUN size	181
Using dynamic capacity expansion and dynamic volume expansion	182

Using the SMdevices utility to find information about LUNs . . . . .	183
Viewing or changing queue depth . . . . .	184
Replacing IBM host bus adapters on a system. . . . .	186
Remotely installing Linux (SAN boot) . . . . .	191
Software requirements . . . . .	191
Hardware requirements . . . . .	192
Assumptions . . . . .	192
Preparing for the SAN boot procedure . . . . .	192
Steps for performing the SAN boot procedure . . . . .	192
Completing the SLES procedure . . . . .	194
Completing the RHEL procedure . . . . .	194
<b>Chapter 6. Completing the software configuration . . . . .</b>	<b>197</b>
Overview of heterogeneous host configurations . . . . .	197
Using the Task Assistant . . . . .	197
Configuring storage subsystems . . . . .	201
Performing an initial automatic discovery of storage subsystems . . . . .	201
Creating arrays and logical drives . . . . .	202
Configuring alert notifications . . . . .	205
Renaming storage subsystems . . . . .	206
Creating a storage subsystem profile . . . . .	206
Performing other storage subsystem management tasks . . . . .	207
<b>Chapter 7. Using DS4000 Storage Manager with high-availability cluster services . . . . .</b>	<b>209</b>
General information. . . . .	209
Using cluster services on HP-UX systems . . . . .	209
Using cluster services on Solaris systems . . . . .	210
General hardware requirements . . . . .	210
System dependencies . . . . .	210
Using cluster services on AIX systems . . . . .	211
General hardware requirements . . . . .	211
High Availability Cluster Multi-Processing . . . . .	211
Parallel System Support Programs and General Parallel File System . . . . .	213
GPFS, PSSP, and HACMP cluster configuration diagrams . . . . .	213
<b>Appendix A. MC/Service Guard configuration details . . . . .</b>	<b>221</b>
<b>Appendix B. JNI and QLogic host bus adapter settings . . . . .</b>	<b>223</b>
JNI HBA card settings . . . . .	223
Configuration settings for FCE-1473/FCE-6460/FCX2-6562/FCC2-6562 . . . . .	223
Configuration settings for FCE-1063/FCE2-1063/FCE-6410/FCE2-6410 . . . . .	224
Configuration settings for FCI-1063 . . . . .	225
Configuration settings for FC64-1063 . . . . .	227
QLogic HBA card settings . . . . .	228
<b>Appendix C. Downloading ESM firmware and drive firmware . . . . .</b>	<b>229</b>
Verifying and downloading ESM firmware. . . . .	229
Verifying current ESM firmware version . . . . .	229
Downloading ESM firmware. . . . .	230
Automatic ESM firmware synchronization. . . . .	232
Downloading drive firmware. . . . .	232
Downloading drive firmware with Storage Manager version 9.1x and higher . . . . .	232
Downloading drive firmware with Storage Manager version 8.x. . . . .	234



<b>Appendix D. Using the IBM System Storage DS4000 Controller Firmware Upgrade Tool</b> . . . . .	235
IBM System Storage DS4000 Controller Firmware Upgrade Tool overview . . . . .	235
Checking the device health conditions . . . . .	235
Installing the upgrade tool . . . . .	236
Adding a storage subsystem . . . . .	236
Downloading the firmware . . . . .	237
Viewing the IBM System Storage DS4000 Controller Firmware Upgrade Tool log file . . . . .	240
<b>Appendix E. Limitations</b> . . . . .	241
AIX . . . . .	241
HP-UX . . . . .	241
Solaris . . . . .	243
<b>Appendix F. Connecting HBAs in a FC switch environment.</b> . . . . .	245
<b>Appendix G. DS4000 Diagnostic Data Capture (DDC)</b> . . . . .	247
DDC information . . . . .	247
DDC function implementation . . . . .	247
DDC MEL events . . . . .	249
<b>Appendix H. Accessibility</b> . . . . .	251
<b>Appendix I. Additional DS4000 documentation.</b> . . . . .	253
DS4000 Storage Manager Version 10 library . . . . .	253
DS4800 Storage Subsystem library . . . . .	254
DS4700 Storage Subsystem library . . . . .	255
DS4500 Storage Subsystem library . . . . .	256
DS4400 Storage Subsystem library . . . . .	257
DS4300 Storage Subsystem library . . . . .	258
DS4200 Express Storage Subsystem library . . . . .	259
DS4100 Storage Subsystem library . . . . .	260
DS4000 Storage Expansion Enclosure documents . . . . .	261
Other DS4000 and DS4000-related documents . . . . .	262
<b>Notices</b> . . . . .	263
Trademarks. . . . .	264
<b>Glossary</b> . . . . .	265
<b>Index</b> . . . . .	275



---

## Figures

1. In-band managed storage subsystems . . . . .	9
2. Out-of-band managed storage subsystems . . . . .	11
3. Sample network using both out-of-band and in-band managed storage subsystems . . . . .	13
4. Listing premium features . . . . .	19
5. DS4000/AIX system configuration. . . . .	48
6. Controller Properties window . . . . .	51
7. <b>lsdev</b> command, example 1. . . . .	52
8. <b>lsdev</b> command, example 2. . . . .	52
9. <b>lsdev</b> command, example 3. . . . .	53
10. <b>lsdev</b> command, example 4. . . . .	53
11. <b>fget_config</b> command, example 1 . . . . .	54
12. <b>fget_config</b> command, example 2 . . . . .	54
13. <b>fget_config</b> command, example 3 . . . . .	55
14. <b>fget_config</b> command, example 4 . . . . .	56
15. <b>lsattr</b> command example . . . . .	57
16. Change Mappings window . . . . .	59
17. <b>Example 1:</b> Displaying the attribute settings for a dar . . . . .	67
18. <b>Example 2:</b> Displaying the attribute settings for a dac . . . . .	67
19. <b>Example 3:</b> Displaying the attribute settings for an hdisk . . . . .	68
20. Sample SMdevices command output (method 1). . . . .	101
21. Sample SMdevices command output (method 2). . . . .	102
22. The task assistant in the Enterprise Management window . . . . .	199
23. The task assistant in the Subsystem Management window . . . . .	200
24. Subsystem Management window . . . . .	201
25. Collect All Support Data window. . . . .	203
26. Cluster configuration with single DS4000 storage subsystem—one to four partitions. . . . .	214
27. Cluster configuration with three DS4000 storage subsystems—one partition per DS4000 . . . . .	215
28. Cluster configuration with four DS4000 storage subsystems—one partition per DS4000 . . . . .	216
29. RVSD cluster configuration with two DS4000 storage subsystems—two partitions per DS4000 . . . . .	217
30. HACMP/GPFS cluster configuration with one DS4000 storage subsystem—one partition . . . . .	218
31. HACMP/GPFS cluster configuration with two DS4000 storage subsystems—two partitions per DS4000. . . . .	219
32. Selection Addition Method window . . . . .	237
33. Download Firmware window . . . . .	238
34. Download progress window . . . . .	239
35. Firmware activating window . . . . .	240
36. Fibre channel fabric switch environment connecting host servers to a DS4000 Storage Server . . . . .	245



---

## Tables

1. Where to find DS4000 installation and configuration procedures . . . . .	xiv
2. Latest firmware versions by storage subsystem model . . . . .	2
3. Installation sequences of DS4000 Storage Manager software packages by host type . . . . .	5
4. Maximum number of logical drives per partition. . . . .	15
5. Examples of possible configurations with more than 32 logical drives . . . . .	15
6. Supported DS4000 expansion enclosures and other hardware for AIX, HP-UX, Solaris, and Linux on POWER systems . . . . .	21
7. Firmware versions that support concurrent download (AIX) . . . . .	39
8. AIX file sets required for RDAC, fibre channel attachment, and HBAs . . . . .	46
9. Attributes for dar devices . . . . .	60
10. Attributes for dac devices. . . . .	62
11. Attributes for hdisk devices . . . . .	63
12. Minimum AIX operating systems and file set versions required for supporting HBA hot swap . . . . .	72
13. HP-UX kernel parameter configuration requirements . . . . .	84
14. Firmware versions that support concurrent download (HP-UX) . . . . .	93
15. Sample record of logical drive preferred and alternate paths . . . . .	103
16. Firmware versions that support concurrent download (Solaris). . . . .	118
17. JNI model numbers and configuration files . . . . .	124
18. /kernel/drv/lpfc.conf settings for using Emulex HBAs . . . . .	132
19. Firmware versions that support concurrent download (Linux on POWER). . . . .	171
20. Configuration settings for FCE-1473/FCE-6460/FCX2-6562/FCC2-6562 . . . . .	223
21. Configuration settings for FCE-1063/FCE2-1063/FCE-6410/FCE2-6410 . . . . .	224
22. Configuration settings for FCI-1063 . . . . .	226
23. Configuration settings for FC64-1063 . . . . .	227
24. Configuration settings for QL2342 . . . . .	228
25. Recovery Step 2 . . . . .	248
26. Recovery Step 4 . . . . .	248
27. Recovery Step 5 . . . . .	248
28. DS4000 Storage Manager alternate keyboard operations . . . . .	251
29. DS4000 Storage Manager Version 10 titles by user tasks . . . . .	253
30. DS4800 Storage Subsystem document titles by user tasks . . . . .	254
31. DS4700 Storage Subsystem document titles by user tasks . . . . .	255
32. DS4500 Storage Subsystem document titles by user tasks . . . . .	256
33. DS4400 Storage Subsystem document titles by user tasks . . . . .	257
34. DS4300 Storage Subsystem document titles by user tasks . . . . .	258
35. DS4200 Express Storage Subsystem document titles by user tasks . . . . .	259
36. DS4100 Storage Subsystem document titles by user tasks . . . . .	260
37. DS4000 Storage Expansion Enclosure document titles by user tasks . . . . .	261
38. DS4000 and DS4000–related document titles by user tasks . . . . .	262



---

## About this document

This document provides information about how to set up, install, configure, and work with the IBM® System Storage® DS4000 Storage Manager Version 10.10 in the following host environments:

- AIX®
- HP-UX
- Solaris
- SUSE Linux® Enterprise Server 9 (SLES 9) on POWER™
- SUSE Linux Enterprise Server 10 (SLES 10) on POWER
- Red Hat Enterprise Linux 4 (RHEL 4) on POWER.
- Red Hat Enterprise Linux 5 (RHEL 5) on POWER—SMclient *only*

Use this document to:

- Determine the hardware and software that is required to install the DS4000 Storage Manager software into your subsystem network
- Install the DS4000 Storage Manager software
- Upgrade the controller's nonvolatile storage random access memory (NVSRAM) and firmware
- Configure the host subsystem
- Identify management features that are unique to your specific installation

For information about installing Storage Manager on other host operating systems, see the *IBM System Storage DS4000 Storage Manager Version 10 Installation and Host Support Guide for Windows 2000/Server 2003, NetWare, VMWare ESX Server, and Linux*.

This document does not cover hardware installation or integration. For information about these topics, see the DS4000 Installation and Host Guide that is appropriate for your storage subsystem. See Appendix H, "Accessibility," on page 251 for a list of these documents.

---

## Who should read this document

This document is intended for system administrators and storage administrators who are responsible for installing storage management software.

Readers should have knowledge of the following concepts:

- Redundant array of independent disks (RAID)
- Small computer system interface (SCSI)
- Fibre channel and serial ATA (SATA) technology

Readers should also have working knowledge of the applicable host operating systems that are used with DS4000 Storage Manager.

---

## DS4000 Storage Subsystem installation tasks - General overview

Table 1 on page xiv provides a sequential list of many installation and configuration tasks that are common to most DS4000™ configurations. When you install and configure your DS4000 storage subsystem, refer to this table to find the documentation that explains how to complete each task.

Table 1. Where to find DS4000 installation and configuration procedures

	Installation task	Where to find information or procedures
1	Plan the installation	<ul style="list-style-type: none"> <li>• <i>DS4000 Storage Manager Concepts Guide</i></li> <li>• <i>DS4000 Storage Manager Installation and Host Support Guide for AIX, HP-UX, Solaris, and Linux on POWER</i></li> <li>• <i>DS4000 Storage Manager Installation and Host Support Guide for Windows® 2000/Server 2003/2008, NetWare, VMWare ESX Server, and Linux</i></li> <li>• <i>DS4100 Storage Subsystem Installation, User's, and Maintenance Guide</i></li> <li>• <i>DS4200 Express Storage™ Subsystem Installation, User's, and Maintenance Guide</i></li> <li>• <i>DS4300 Storage Subsystem Installation, User's, and Maintenance Guide</i></li> <li>• <i>DS4400 Fibre Channel Storage Server Installation and Support Guide</i></li> <li>• <i>DS4500 Storage Subsystem Installation, User's, and Maintenance Guide</i></li> <li>• <i>DS4700 Express Storage Subsystem Installation, User's, and Maintenance Guide</i></li> <li>• <i>IBM System Storage™ Quick Start Guide, Quick reference for the DS4800</i></li> <li>• <i>DS4800 Storage Subsystem Installation, User's, and Maintenance Guide</i></li> <li>• <i>IBM System Storage Quick Start Guide, Quick reference for the DS4700 and DS4200, Sections 2, 3, and 4 also for installing the EXP810 and EXP420</i></li> </ul>
2	Mount the DS4000 storage subsystem in the rack	<ul style="list-style-type: none"> <li>• <i>DS4800 Storage Subsystem Installation, User's, and Maintenance Guide</i></li> <li>• <i>IBM System Storage Quick Start Guide, Quick reference for the DS4800</i></li> <li>• <i>DS4700 Express Storage Subsystem Installation, User's, and Maintenance Guide</i></li> <li>• <i>IBM System Storage Quick Start Guide, Quick reference for the DS4700 and DS4200, Sections 2, 3, and 4 also for installing the EXP810 and EXP420</i></li> <li>• <i>DS4400 and DS4500 Rack Mounting Instructions</i></li> <li>• <i>DS4300 Rack Mounting Instructions</i></li> <li>• <i>DS4200 Express Storage Subsystem Installation, User's, and Maintenance Guide</i></li> <li>• <i>DS4100 Storage Subsystem Installation, User's and Maintenance Guide</i></li> </ul>



Table 1. Where to find DS4000 installation and configuration procedures (continued)

	<b>Installation task</b>	<b>Where to find information or procedures</b>
<b>3</b>	Mount the DS4000 EXP storage expansion unit in the rack	<ul style="list-style-type: none"> <li>• <i>DS4000 EXP100 Storage Expansion Unit Installation, User's and Maintenance Guide</i></li> <li>• <i>DS4000 EXP420 Storage Expansion Enclosures Installation, User's, and Maintenance Guide</i></li> <li>• <i>DS4000 EXP700 and EXP710 Storage Expansion Enclosures Installation, User's, and Maintenance Guide</i></li> <li>• <i>DS4000 EXP810 Storage Expansion Enclosures Installation, User's, and Maintenance Guide</i></li> <li>• <i>FAStT EXP500 Installation and User's Guide</i></li> <li>• <i>IBM System Storage Quick Start Guide, Quick reference for the DS4700 and DS4200, Sections 2, 3, and 4 also for installing the EXP810 and EXP420</i></li> </ul>
<b>4</b>	Route the storage expansion unit fibre channel cables	<ul style="list-style-type: none"> <li>• <i>DS4100 Storage Subsystem Installation, User's, and Maintenance Guide</i></li> <li>• <i>DS4200 Express Storage Subsystem Installation, User's, and Maintenance Guide</i></li> <li>• <i>DS4300 Storage Subsystem Installation, User's, and Maintenance Guide</i></li> <li>• <i>DS4400 Fibre Channel Cabling Instructions</i></li> <li>• <i>DS4500 Storage Subsystem Installation, User's, and Maintenance Guide</i></li> <li>• <i>DS4700 Express Storage Subsystem Installation, User's, and Maintenance Guide</i></li> <li>• <i>IBM System Storage Quick Start Guide, Quick reference for the DS4700 and DS4200, Sections 2, 3, and 4 also for installing the EXP810 and EXP420</i></li> <li>• <i>DS4800 Storage Subsystem Installation, User's, and Maintenance Guide</i></li> <li>• <i>IBM System Storage Quick Start Guide, Quick reference for the DS4800</i></li> </ul>
<b>5</b>	Route the host server fibre channel cables	<ul style="list-style-type: none"> <li>• <i>DS4100 Storage Subsystem Installation, User's, and Maintenance Guide</i></li> <li>• <i>DS4200 Express Storage Subsystem Installation, User's, and Maintenance Guide</i></li> <li>• <i>DS4300 Storage Subsystem Installation, User's, and Maintenance Guide</i></li> <li>• <i>DS4400 Fibre Channel Cabling Instructions</i></li> <li>• <i>DS4500 Storage Subsystem Installation, User's, and Maintenance Guide</i></li> <li>• <i>DS4700 Express Storage Subsystem Installation, User's, and Maintenance Guide</i></li> <li>• <i>IBM System Storage Quick Start Guide, Quick reference for the DS4700 and DS4200, Sections 2, 3, and 4 also for installing the EXP810 and EXP420</i></li> <li>• <i>DS4800 Storage Subsystem Installation, User's, and Maintenance Guide</i></li> <li>• <i>IBM System Storage Quick Start Guide, Quick reference for the DS4800</i></li> </ul>

Table 1. Where to find DS4000 installation and configuration procedures (continued)

	Installation task	Where to find information or procedures
6	Power up the subsystem	<ul style="list-style-type: none"> <li>• <i>DS4100 Storage Subsystem Installation, User's, and Maintenance Guide</i></li> <li>• <i>DS4200 Express Storage Subsystem Installation, User's, and Maintenance Guide</i></li> <li>• <i>DS4300 Storage Subsystem Installation, User's, and Maintenance Guide</i></li> <li>• <i>DS4400 Fibre Channel Storage Server Installation and Support Guide</i></li> <li>• <i>DS4500 Storage Subsystem Installation, User's, and Maintenance Guide</i></li> <li>• <i>DS4700 Express Storage Subsystem Installation, User's, and Maintenance Guide</i></li> <li>• <i>IBM System Storage Quick Start Guide, Quick reference for the DS4700 and DS4200, Sections 2, 3, and 4 also for installing the EXP810 and EXP420</i></li> <li>• <i>DS4800 Storage Subsystem Installation, User's, and Maintenance Guide</i></li> <li>• <i>IBM System Storage Quick Start Guide, Quick reference for the DS4800</i></li> </ul>
7	Configure DS4000 network settings	<ul style="list-style-type: none"> <li>• <i>DS4100 Storage Subsystem Installation, User's, and Maintenance Guide</i></li> <li>• <i>DS4200 Express Storage Subsystem Installation, User's, and Maintenance Guide</i></li> <li>• <i>DS4300 Storage Subsystem Installation, User's, and Maintenance Guide</i></li> <li>• <i>DS4400 Fibre Channel Storage Server Installation and Support Guide</i></li> <li>• <i>DS4500 Storage Subsystem Installation, User's, and Maintenance Guide</i></li> <li>• <i>DS4700 Express Storage Subsystem Installation, User's, and Maintenance Guide</i></li> <li>• <i>IBM System Storage Quick Start Guide, Quick reference for the DS4700 and DS4200, Sections 2, 3, and 4 also for installing the EXP810 and EXP420</i></li> <li>• <i>DS4800 Storage Subsystem Installation, User's, and Maintenance Guide</i></li> <li>• <i>IBM System Storage Quick Start Guide, Quick reference for the DS4800</i></li> </ul>
8	Zone the fabric switch (SAN-attached only)	<ul style="list-style-type: none"> <li>• <i>DS4000 Storage Manager Installation and Host Support Guide for AIX, HP-UX, Solaris, and Linux on POWER</i></li> <li>• <i>DS4000 Storage Manager Installation and Host Guide for Windows 2000/Server 2003/2008, NetWare, VMWare ESX Server, and Linux</i></li> <li>• <i>DS4000 Storage Manager Copy Services Guide</i> (describes switch zoning for the Remote Mirror Option)</li> <li>• See also the documentation provided by the switch manufacturer.</li> </ul>

Table 1. Where to find DS4000 installation and configuration procedures (continued)

	Installation task	Where to find information or procedures
9	Install DS4000 Storage Manager software on the management station	<ul style="list-style-type: none"> <li>• <i>DS4000 Storage Manager Installation and Host Support Guide for AIX, HP-UX, Solaris, and Linux on POWER</i></li> <li>• <i>DS4000 Storage Manager Installation and Host Support Guide for Windows 2000/Server 2003/2008, NetWare, VMWare ESX Server, and Linux</i></li> </ul>
10	Install host software (failover drivers) on host server	<ul style="list-style-type: none"> <li>• <i>IBM System Storage Quick Start Guide, Quick reference for the DS4700 and DS4200, Sections 2, 3, and 4 also for installing the EXP810 and EXP420</i></li> </ul>
11	Start DS4000 Storage Manager	<ul style="list-style-type: none"> <li>• <i>IBM System Storage Quick Start Guide, Quick reference for the DS4800</i></li> </ul>
12	Set the DS4000 Storage Manager clock	<ul style="list-style-type: none"> <li>• DS4000 Storage Manager online help (for post-installation tasks)</li> </ul>
13	Set the DS4000 Storage Manager host default type	
14	Verify DS4000 subsystem health	<ul style="list-style-type: none"> <li>• <i>DS4100 Storage Subsystem Installation, User's, and Maintenance Guide</i></li> <li>• <i>DS4200 Express Storage Subsystem Installation, User's, and Maintenance Guide</i></li> <li>• <i>DS4300 Storage Subsystem Installation, User's, and Maintenance Guide</i></li> <li>• <i>DS4400 Fibre Channel Storage Server Installation and Support Guide</i></li> <li>• <i>DS4500 Storage Subsystem Installation, User's, and Maintenance Guide</i></li> <li>• <i>DS4700 Express Storage Subsystem Installation, User's, and Maintenance Guide</i></li> <li>• <i>DS4800 Storage Subsystem Installation, User's, and Maintenance Guide</i></li> </ul>
15	Enable DS4000 Storage Manager premium feature keys	<p><b>Copy Services premium features</b> <i>DS4000 Storage Manager Copy Services Guide</i></p> <p><b>FC/SATA Intermix premium feature</b> <i>DS4000 Fibre Channel and Serial ATA Intermix Premium Feature Installation Overview</i></p> <p><b>Storage Partitioning (and general premium features information)</b></p> <ul style="list-style-type: none"> <li>• <i>DS4000 Storage Manager Concepts Guide</i></li> <li>• <i>DS4000 Storage Manager Installation and Host Support Guide for AIX, HP-UX, Solaris, and Linux on POWER</i></li> <li>• <i>DS4000 Storage Manager Installation and Host Support Guide for Windows 2000/Server 2003/2008, NetWare, VMWare ESX Server, and Linux</i></li> </ul>

Table 1. Where to find DS4000 installation and configuration procedures (continued)

	Installation task	Where to find information or procedures
16	Configure arrays and logical drives	<ul style="list-style-type: none"> <li>• <i>DS4000 Storage Manager Installation and Host Support Guide for AIX, HP-UX, Solaris, and Linux on POWER</i></li> <li>• <i>DS4000 Storage Manager Installation and Host Support Guide for Windows 2000/Server 2003/2008, NetWare, VMWare ESX Server, and Linux</i></li> </ul>
17	Configure host partitions	<ul style="list-style-type: none"> <li>• <i>IBM System Storage Quick Start Guide, Quick reference for the DS4700 and DS4200, Sections 2, 3, and 4 also for installing the EXP810 and EXP420</i></li> </ul>
18	Verify host access to DS4000 storage	<ul style="list-style-type: none"> <li>• <i>IBM System Storage Quick Start Guide, Quick reference for the DS4800</i></li> <li>• DS4000 Storage Manager online help</li> </ul>

## How this document is organized

Chapter 1, “Overview and introduction,” on page 1 provides a summary of the DS4000 Storage Manager product, including information about product resources additional to this document.

Chapter 2, “Installing and configuring storage management software on AIX host systems,” on page 27 provides information about how to install and configure DS4000 Storage Manager with an AIX host operating system and contains information about high-availability clustering system options.

Chapter 3, “Installing and configuring storage management software on HP-UX host systems,” on page 83 provides information about how to install and configure DS4000 Storage Manager with an HP-UX host operating system.

Chapter 4, “Installing and configuring storage management software on Solaris host systems,” on page 107 provides information about how to install and configure DS4000 Storage Manager with a Solaris host operating system.

Chapter 5, “Installing and configuring storage management software on POWER-based Linux host systems,” on page 151 provides information about how to configure a DS4000 Storage Manager subsystem with SUSE Linux Enterprise Server and Red Hat Enterprise Linux operating systems on a POWER or Series p-based host.

Chapter 6, “Completing the software configuration,” on page 197 provides information about how to install and configure DS4000 Storage Manager with a Solaris host operating system.

Chapter 7, “Using DS4000 Storage Manager with high-availability cluster services,” on page 209 provides step-by-step instructions for post-installation tasks, such as how to create storage arrays, logical drives, and storage partitions.

Appendix A, “MC/Service Guard configuration details,” on page 221 discusses the configuration distribution process for an HP-UX host operating system.

Appendix B, “JNI and QLogic host bus adapter settings,” on page 223 provides detailed settings for the various host bus adapter (HBA) cards for Sun Solaris.

Appendix C, “Downloading ESM firmware and drive firmware,” on page 229 describes how to download current ESM firmware to a DS4000 EXP storage expansion enclosure and current drive firmware to a DS4000 storage subsystem and provides the procedures for verifying and downloading Environmental Service Module (ESM) firmware.

Appendix D, “Using the IBM System Storage DS4000 Controller Firmware Upgrade Tool,” on page 235 explains how to use this tool to upgrade Storage Manager firmware versions 05.xx. and 06.xx to the current 07.10.xx.xx and provides the steps to a successful migration.

Appendix E, “Limitations,” on page 241 provides the procedure for how to correct the primary and alternate paths of the imported volume groups that are changed after using vgimport -m -s with LVM commands.

Appendix F, “Connecting HBAs in a FC switch environment,” on page 245 provides an example of a fibre channel fabric switch configuration, and a Web site that contains links to switch documentation.

Appendix G, “DS4000 Diagnostic Data Capture (DDC),” on page 247 provides information about saving event data for a critical internal controller error.

Appendix H, “Accessibility,” on page 251 offers alternatives to navigating in the DS4000 Storage Manager software for those of restricted mobility.

Appendix I, “Additional DS4000 documentation,” on page 253 provides a comprehensive listing of all DS4000-related documentation.

---

## Notices used in this document

This document contains the following notices that are designed to highlight key information:

- Note:** These notices provide tips, guidance, or advice.
- Important:** These notices provide information or advice that might help you avoid inconvenient or problem situations.
- Attention:** These notices indicate possible damage to programs, devices or data. An attention notice is placed just before the instruction or situation in which damage could occur.

---

## Getting information, help, and service

If you need help, service, or technical assistance or just want more information about IBM products, you will find a wide variety of sources available from IBM to assist you. This section contains information about where to go for additional information about IBM and IBM products, what to do if you experience a problem with your system, and whom to call for service, if it is necessary.

## Before you call

Before you call, take these steps to try to solve the problem yourself:

- Check all cables to make sure that they are connected.
- Check the power switches to make sure that the system is turned on.
- Use the troubleshooting information in your system documentation, and use the diagnostic tools that come with your system.

- Check for technical information, hints, tips, and new device drivers at the IBM support Web site pages that are listed in this section.
- Use an IBM discussion forum on the IBM Web site to ask questions.

You can solve many problems without outside assistance by following the troubleshooting procedures that IBM provides in the DS4000 Storage Manager online help or in the documents that are provided with your system and software. The information that comes with your system also describes the diagnostic tests that you can perform. Most subsystems, operating systems, and programs come with information that contains troubleshooting procedures and explanations of error messages and error codes. If you suspect a software problem, see the information for the operating system or program.

## Using the documentation

Information about your IBM system and preinstalled software, if any, is available in the documents that come with your system. This includes printed books, online documents, readme files, and help files. See the troubleshooting information in your system documentation for instructions for using the diagnostic programs. The troubleshooting information or the diagnostic programs might tell you that you need additional or updated device drivers or other software.

## Finding DS4000 readme files

1. Go to the following Web site:  
[www.ibm.com/systems/support/storage/disk](http://www.ibm.com/systems/support/storage/disk)
2. Click the link for your Storage Subsystem (for example, **DS4800**).
3. When the subsystem support page opens, click the **Download** tab.
4. Under the Download tab, click **Storage Manager, firmware, HBA, tools, support & pubs (including readmes)**.
5. Now, click the appropriate tab for the type of readme file that you are looking for:
  - **Firmware**
  - **Storage Mgr**
  - **HBA**
  - **Tools**

A table displays as you click each tab.

6. In the table, click on the appropriate link in the **Current® version and readmes** column.
7. Click the link for the readme file.

## Web sites

The most up-to-date information about DS4000 storage subsystems and DS4000 Storage Manager, including documentation and the most recent software, firmware, and NVSRAM downloads, can be found at the following Web sites.

### DS4000 Midrange Disk Systems

Find the latest information about IBM System Storage disk storage systems, including all of the DS4000 storage subsystems:

[www.ibm.com/servers/storage/disk/ds4000](http://www.ibm.com/servers/storage/disk/ds4000)

### IBM System Storage products

Find information about all IBM System Storage products:

[www.storage.ibm.com](http://www.storage.ibm.com)

### **Support for IBM System Storage disk storage systems**

Find links to support pages for all IBM System Storage disk storage systems, including DS4000 storage subsystems and expansion units:

[www.ibm.com/systems/support/storage/disk](http://www.ibm.com/systems/support/storage/disk)

### **System Storage DS4000 interoperability matrix**

Find the latest information about operating system and HBA support, clustering support, storage area network (SAN) fabric support, and DS4000 Storage Manager feature support:

[www.ibm.com/servers/storage/disk/ds4000/interop-matrix.html](http://www.ibm.com/servers/storage/disk/ds4000/interop-matrix.html)

### **Storage Area Network (SAN) support**

Find information about using SAN switches, including links to user guides and other documents:

[www.ibm.com/systems/support/storage/san](http://www.ibm.com/systems/support/storage/san)

### **DS4000 technical support**

Find downloads, hints and tips, documentation, parts information, HBA and fibre channel support:

<http://www.ibm.com/systems/support/storage/disk>

Select your Storage Subsystem (for example, **DS4800**).

### **Premium feature activation**

Activate a DS4000 premium feature by using the online tool:

[www-912.ibm.com/PremiumFeatures/jsp/keyInput.jsp](http://www-912.ibm.com/PremiumFeatures/jsp/keyInput.jsp)

### **IBM publications center**

Find IBM publications:

[www.ibm.com/shop/publications/order/](http://www.ibm.com/shop/publications/order/)

### **Support for System p™ servers**

Find the latest information supporting System p AIX and Linux servers:

[www.ibm.com/systems/support/supportsite.wss/  
brandmain?brandind=5000025](http://www.ibm.com/systems/support/supportsite.wss/brandmain?brandind=5000025)

### **Support for System x™ servers**

Find the latest information supporting System x Intel®- and AMD-based servers:

[www.ibm.com/systems/support/supportsite.wss/  
brandmain?brandind=5000008](http://www.ibm.com/systems/support/supportsite.wss/brandmain?brandind=5000008)

### **Fix delivery center for AIX and Linux on POWER**

Find the latest AIX and Linux on POWER information and downloads:

[www-912.ibm.com/eserver/support/fixes/fcgui.jsp](http://www-912.ibm.com/eserver/support/fixes/fcgui.jsp)

In the **Product family** drop down menu, select **UNIX® servers**. Then select your product and fix type from the subsequent drop down menus.

### **@server System p and AIX information center**

Find everything you need to know about using AIX with System p and POWER servers:

[publib.boulder.ibm.com/infocenter/pseries/index.jsp?](http://publib.boulder.ibm.com/infocenter/pseries/index.jsp?)

## Software service and support

Through IBM Support Line, for a fee you can get telephone assistance with usage, configuration, and software problems. For information about which products are supported by Support Line in your country or region, go to the following Web site:

[www.ibm.com/services/sl/products](http://www.ibm.com/services/sl/products)

For more information about the IBM Support Line and other IBM services, go to the following Web sites:

- [www.ibm.com/services](http://www.ibm.com/services)
- [www.ibm.com/planetwide](http://www.ibm.com/planetwide)

## Hardware service and support

You can receive hardware service through IBM Integrated Technology Services or through your IBM reseller, if your reseller is authorized by IBM to provide warranty service. Go to the following Web site for support telephone numbers:

[www.ibm.com/planetwide](http://www.ibm.com/planetwide)

In the U.S. and Canada, hardware service and support is available 24 hours a day, 7 days a week. In the U.K., these services are available Monday through Friday, from 9 a.m. to 6 p.m.

## Fire suppression systems

A fire suppression system is the responsibility of the customer. The customer's own insurance underwriter, local fire marshal, or a local building inspector, or both, should be consulted in selecting a fire suppression system that provides the correct level of coverage and protection. IBM designs and manufactures equipment to internal and external standards that require certain environments for reliable operation. Because IBM does not test any equipment for compatibility with fire suppression systems, IBM does not make compatibility claims of any kind nor does IBM provide recommendations on fire suppression systems.

## How to send your comments

Your feedback is important to help us provide the highest quality information. If you have any comments about this document, you can submit them in one of the following ways:

### E-mail

Submit your comments by e-mail to:

[starpubs@us.ibm.com](mailto:starpubs@us.ibm.com)

Be sure to include the name and order number of the document and, if applicable, the specific location of the text that you are commenting on, such as a page number or table number.

### Mail

Fill out the Readers' Comments form (RCF) at the back of this document and return it by mail or give it to an IBM representative.

If the RCF has been removed, send your comments to:

International Business Machines Corporation  
Information Development  
Department GZW



9000 South Rita Road  
Tucson, Arizona  
USA  
85744-0001

Be sure to include the name and order number of the document and, if applicable, the specific location of the text that you are commenting on, such as a page number or table number.



---

# Chapter 1. Overview and introduction

---

## Overview

### The DS4000 Storage Manager

The DS4000 Storage Manager software is used to configure, manage and troubleshoot the IBM System Storage DS4000 Storage Server.

It is used primarily to configure RAID arrays and logical drives, assign logical drives to hosts, replace and rebuild failed disk drives, expand the size of the arrays and logical drives, and convert from one RAID level to another. It allows troubleshooting and management tasks, like checking the status of the Storage Server components, updating the firmware of the RAID controllers, and managing the Storage Server. Finally, it offers advanced functions such as FlashCopy®, Volume Copy, and Enhanced Remote Mirroring.

This chapter includes discussions of the following topics:

- “Readme files and concepts”
- “Supported controller firmware versions” on page 2
- “Product updates and support notifications” on page 3
- “DS4000 Storage Manager client software packages” on page 4
- “Storage subsystem management methods” on page 8
- “Setting up IP addresses for DS4000 storage controllers” on page 13
- “DS4000 Storage Manager performance planning” on page 14
- “DS4000 limitations” on page 8
- “DS4000 Storage Manager premium features” on page 16
- “DS4000 hardware and firmware requirements for AIX, HP-UX, Solaris, and Linux on POWER” on page 20

#### Readme files and concepts

Before you install DS4000 Storage Manager software, consult the following documentation:

##### Storage Manager readme files

Read these first.

**Important:** Updated readme files contain the latest device driver versions, firmware levels and other information that supersede this document.

To access the most recent DS4000 Storage Manager readme files, complete the following steps:

1. Go to the following Web site: [www-1.ibm.com/servers/storage/support/disk/](http://www-1.ibm.com/servers/storage/support/disk/)
2. Click the link for your storage subsystem (for example, **DS4800**).
3. When the subsystem support page opens, click the **Install and Use** tab, then click the **DS4000 Storage Manager Pubs and Code** link. The Downloads page for the subsystem opens.
4. When the download page opens, ensure that the **Storage Mgr** tab is selected. A table displays.

5. In the table, find the entry that lists the Storage Manager package for your operating system, then click on the corresponding **v10.10** link in the **Current version and readmes** column. The Storage Manager page for your operating system opens.
6. Click the link for the readme file.

### IBM DS4000 Storage Manager Concepts Guide

Use this reference document to become familiar with the terminology and the features of the DS4000 Storage Manager software. This document is available on the DS4000 Storage Manager installation CD and at the Web site listed above.

### Supported controller firmware versions

IBM DS4000 Storage Manager version 10.10 host software supports the new features that are incorporated into all releases of controller firmware version 07.10.xx.xx, and manages DS4000 storage subsystems with all generally-released controller firmware versions (05.30.xx.xx to 07.10.xx.xx).

All of the controller firmware versions that are listed in Table 2 are available free-of-charge.

Each DS4000 storage subsystem supports only one particular controller firmware code thread. Please see the **Current firmware version** column in Table 2 to find the latest controller firmware code for a particular DS4000 storage subsystem model.

See “New features and enhancements” on page 7 for new features that are associated with the 07.10.xx.xx controller firmware.

**Note:** Check the DS4000 Storage Manager readme file for your host operating system for information on latest supported controller firmware code levels available for all DS4000 storage subsystem models. See “Readme files and concepts” on page 1.

*Table 2. Latest firmware versions by storage subsystem model*

Storage subsystem model	Machine type and model	Current firmware version
IBM System Storage DS4800 Storage Subsystem	1815 - 80A/H, 82A/H, 84A/H, and 88 A/H	07.10.xx.xx (see note 1, below)
IBM System Storage DS4700 Storage Subsystem	1814 - 70A/H, 72A/H	07.10.xx.xx
IBM TotalStorage® DS4500 Storage Subsystem (see note 5)	1742 - 90X/U	06.60.xx.xx
IBM TotalStorage DS4400 Storage Subsystem	1742 - 1RU/RX	06.12.xx.xx
IBM TotalStorage DS4300 Base and Turbo Storage Subsystem (see note 5)	1722 - 60U/X	06.60.xx.xx
IBM TotalStorage DS4300 - Storage Subsystem single controller unit (SCU) (see note 5)	1722 - 6LU/LX	05.34.xx.xx
IBM TotalStorage DS4200 Express	7VA and 7VH	07.10.xx.xx
IBM TotalStorage DS4100 Storage Subsystem	1724 - 100	06.12.xx.xx

Table 2. Latest firmware versions by storage subsystem model (continued)

Storage subsystem model	Machine type and model	Current firmware version
IBM TotalStorage DS4100 Storage Subsystem - single controller unit (SCU)	1SC, 1S_x	06.12.xx.xx
IBM FAST200 Storage Subsystem (see note 4)	3542 - 1RU/RX	05.3x.xx.xx
IBM FAST200 High Availability Storage Subsystem (see note 4)	3542 - 2RU/RX	05.3x.xx.xx
Netfinity® FAST500 RAID Controller Enclosure Unit (see note 3)	3552 - 1RU/RX	05.3x.xx.xx

**Notes:**

1. The DS4800 Model 80A/H does not support controller firmware versions 06.14.xx.xx or 06.15.xx.xx; however, firmware versions 06.23.xx.xx through 07.10.xx.xx are fully supported.
2. With controller firmware 06.12.xx.xx and higher, Storage Manager 10.10 supports DS4100 standard (base) and single-controller (SCU) SATA storage subsystems, and EXP100 SATA storage expansion enclosures.
3. FAST200 and FAST500 storage subsystems are no longer available; therefore, the Storage Manager features that are specific to version 06.1x.xx.xx firmware and above, and corresponding NVSRAM are unavailable for those FAST subsystems. IBM recommends that you use Storage Manager 10.10 software to manage these FAST subsystems, using controller firmware versions 5.3x.xx.xx.

**Product updates and support notifications**

Be sure to download the latest versions of the DS4000 Storage Manager host software, DS4000 storage subsystem controller firmware, DS4000 drive expansion enclosure ESM firmware, and drive firmware at the time of the initial installation and when product updates become available.

<p><b>Important</b></p> <p>Keep your system up to date with the latest firmware and other product updates by subscribing to receive support notifications.</p>
--

For more information about support notifications or the My Support feature, including instructions on how to register, see the following IBM Support Web page:

[www.ibm.com/systems/support/storage/subscribe/moreinfo.html](http://www.ibm.com/systems/support/storage/subscribe/moreinfo.html)

You can also check the **Stay Informed** section of the IBM Disk Support Web site:

[www.ibm.com/servers/storage/support/disk/index.html](http://www.ibm.com/servers/storage/support/disk/index.html)

---

## Introduction

### The DS4000 Storage Manager software

IBM System Storage DS4000 Storage Manager 10.10 consists of a set of client and host tools that enable you to manage the following IBM DS4000 storage subsystems from a storage management station.

See “Supported controller firmware versions” on page 2 for the latest firmware versions that are supported by each storage subsystem model.

## **DS4000 Storage Manager client software packages**

DS4000 Storage Manager contains the following client software packages:

### **SMruntime software**

DS4000 Storage Manager Java <sup>TM</sup> compiler

### **SMesm software**

DS4000 Storage Manager ESM firmware delivery package

### **SMclient software**

DS4000 Storage Manager client package

DS4000 Storage Manager contains the following host software packages:

### **SMagent software**

DS4000 Storage Manager agent package

### **SMutil software**

DS4000 Storage Manager utility package

In addition to this document, see the *IBM DS4000 Storage Manager Concepts Guide* for more information about DS4000 Storage Manager software.

**SMruntime software package:** The DS4000 Storage Manager runtime software, SMruntime, is a Java compiler for the DS4000 Storage Manager client software, SMclient. SMruntime must be installed before SMclient is installed.

**SMesm software package:** The DS4000 Storage Manager Esm software is needed for automatic ESM firmware synchronization. It must be installed before SMclient is installed.

**SMclient software package:** The DS4000 Storage Manager client software, SMclient, is a Java-based graphical user interface (GUI).

SMclient enables you to configure, manage and monitor DS4000 storage subsystems and storage expansion enclosures in a storage subsystem, either through a host system or through a storage management station.

Specifically, SMclient enables you to perform the following tasks:

- Configure disk arrays and logical volumes
- Assign names to arrays and volume groups
- Assign logical volumes to storage partitions
- Replace and rebuild failed disk drives
- Expand the size of arrays
- Expand the size of logical volumes
- Change RAID-type arrays
- Configure and add additional host partitions with the premium partitioning feature
- Monitor the status of DS4000 storage subsystems
- Perform troubleshooting and maintenance tasks, such as downloading controller, ESM and drive firmware and NVSRAM
- View the major events log (MEL)
- Assign redundant RAID controllers
- Expand storage capacity using storage expansion enclosures.

**Note:** For important information about using the DS4000 EXP100 SATA storage expansion enclosure, see *IBM TotalStorage DS4000 EXP100 Storage Expansion Enclosure Installation and User's Guide*.

The SMclient contains two main components:

**Enterprise Management**

This component enables you to add, remove, and monitor storage subsystems in the management domain.

**Subsystem Management**

This component enables you to manage the components of an individual storage subsystem.

**SMagent software package:** The DS4000 Storage Manager software agent package, SMagent, contains optional host-agent software, which you can use to manage storage subsystems through the host fibre channel connection.

**Notes:**

1. You must have a failover driver installed in order to use SMagent.
2. SMagent is not supported with controller firmware version 05.42.xx.xx or with prior versions.

SMagent takes requests from a storage management station that is connected to the host through a network connection, and passes the requests to the storage subsystem controllers through the fibre channel I/O path.

For more information about managing storage subsystems through SMagent, see “In-band (host-agent) management method” on page 9.

**SMutil software package:** You can use the DS4000 Storage Manager utility, SMutil, to register and map new logical drives to the operating system, and to verify mapping.

**Note:** Before installing this package on an HP-UX, Solaris, or Linux host server, check the chapter for your host OS to determine if it is needed.

Install SMutil on all HP-UX, Solaris, and Linux host servers that are attached to a storage subsystem. (The host servers are attached to the storage subsystem through the fibre channel.)

**Software installation sequence**

Install the DS4000 Storage Manager software packages in the sequences shown in Table 3.

*Table 3. Installation sequences of DS4000 Storage Manager software packages by host type*

Step	AIX	HP-UX	Solaris	Linux on POWER
1	SMruntime	SMruntime	SMruntime	SMruntime
2	SMesm	SMesm	SMesm	SMesm
3	SMclient	SMclient	SMclient	SMclient
4	SMagent	SMagent	SMagent	SMagent
5	SMutil	SMutil	SMutil	SMutil
6	Controller firmware and NVSRAM	Controller firmware and NVSRAM	Controller firmware and NVSRAM	Controller firmware and NVSRAM

Table 3. Installation sequences of DS4000 Storage Manager software packages by host type (continued)

Step	AIX	HP-UX	Solaris	Linux on POWER
7	ESM firmware	ESM firmware	ESM firmware	ESM firmware
8	Drive firmware	Drive firmware	Drive firmware	Drive firmware
<b>Location of procedures</b>	"Installing DS4000 Storage Manager" on page 29	"Installing DS4000 Storage Manager" on page 84	"Installing DS4000 Storage Manager" on page 108	"Storage Manager installation and configuration" on page 162

## The storage management station

The *storage management station* is the system that is responsible for managing all, or a portion of, a storage network. It communicates with the network management agents that reside in the managed nodes using a network management protocol, such as Simple Network Management Protocol (SNMP).

Storage management commands are sent to the storage subsystem controllers, where the controller firmware validates and runs the commands, and then returns status and configuration information to the client software.

A storage management station can be either of the following configurations:

- A remote system, connected to an Ethernet network, that is used to manage one or more storage subsystems
- A host that is connected to the storage subsystem with a fibre channel input/output (I/O) path which is also used to manage the attached storage subsystems

**Note:** Even though you can install the storage management software on a host, the host still uses the Transmission Control Protocol/Internet Protocol (TCP/IP) to communicate with the host-agent. The host-agent communicates with the controller over the fibre channel connection through the *access volume*.

## Finding Storage Manager software and controller firmware

DS4000 Storage Manager software and controller firmware are available on the product CD. You can also download DS4000 Storage Manager software and firmware from the Web. See

[www-1.ibm.com/servers/storage/support/disk/](http://www-1.ibm.com/servers/storage/support/disk/)

1. At the support Web site, click the link for your storage subsystem (for example, **DS4800**).
2. When the subsystem page opens, click the **Download** tab, then click **Storage Manager, firmware, HBA and tools (including readmes)**.
3. For controller firmware, click the **Firmware** tab. For Storage Manager software, click the **Storage Mgr** tab then click on the appropriate link for your host operating system under the **Current Versions and readmes** column.

## DS4000 Storage Manager online help

After you have completed all the installation and configuration procedures that are provided in this document, refer to the following online help systems. The online help contains information that is common to all operating system environments.



You can access the help systems from the Enterprise Management and Subsystem Management windows in DS4000 Storage Manager by clicking **Help** on the toolbar or pressing F1.

#### **Enterprise Management Help window**

Use this online help system to learn more about working with the entire management domain.

#### **Subsystem Management Help window**

Use this online help system to learn more about managing individual storage subsystems.

### **New features and enhancements**

DS4000 Storage Manager 10.10 supports controller firmware versions 05.30.xx.xx - 07.10.xx.xx.

**Note:** For information about supported host operating systems and operating system requirements, see the Storage Manager readme file for your operating system. See “Readme files and concepts” on page 1 for instructions that describe how to find the readme files online.

#### ***New features of Storage Manager 10.10:***

*Storage Manager 10.10 (controller firmware 07.10.xx.xx): New features:* Controller firmware version **07.10.xx.xx** supports the following:

- DS4800 Storage Subsystems models
- DS4700 Storage Subsystems models
- DS4200 Express Storage Subsystems
- RAID 6 on DS4700, DS4200 only
  - RAID 6 using a p+q implementation
- Support for greater than 2TB volumes
- Support for RAID 0 and 1 volume groups with more than 30 drives
- Increase maximum number of partitions
  - 128 for DS4200 and DS4700
  - 512 for DS4800
- HP-UX v11.23 full solution
  - Provides a full solution (all client software) for 64-bit HP-UX v11.23 (Itanium2 processor)
- Increased queue depth
  - Increases the controller queue depth to 4096 for the DS4800 controllers and to 2048 for DS4700 and DS4200 controllers
- Increased number of Global Hot Spares
  - Lifts any previous limits on the number of Global Hot Spares allowed per array
- Drive Migration Warning
  - When migrating configured volume groups to an existing array, there will be a warning given if the number of volumes being added will overrun the maximum number of volumes allowed on this particular array.
- Configurable failed drive replacement
  - You will be allowed to specify that a hot spare be a permanent member of a volume group, thus eliminating the copy back portion once the failed drive has been replaced. The replacement drive will be in an unassigned state.

- RAID redundant data verification prior to read
  - Enables verification of redundant RAID data consistency before returning the requested read data back to the host. This feature should be enabled on a volume basis. It will automatically be disabled when a volume is degraded. If a mismatch is detected, the controller will return a Media error—unrecoverable read error (03/11/00). The array will not attempt to correct or recalculate parity automatically. This will support all raid levels.
- 8K cache block size
- Increase to 16 snapshots per volume for DS4800
- Increase the number of snapshots on DS4700
- DS4700 Path Redundancy Improvement
  - Board turn-on DS4700 to allow the alternate controller to access drive channels, when a controller is held in reset or is undergoing SOD processing
- Increase number of mirrors supported
  - Increase the number of mirrors supported on the DS4800 from 64 to 128 and on the DS4700 from 32 to 64
- Create Unmanageable Icon
  - Create a new icon in the Enterprise Management Window to differentiate between *Unresponsive* and *Unmanageable*. The Unmanageable would be any array for which there is no corresponding JAR file.
- Portable Volume Groups, SAFE changes
  - New export and import behavior, which will also include SAFE import changes of premium features.

## DS4000 limitations

Please be aware of the following limitations:

- DS4800 storage subsystems do not support DS4000 EXP700 fibre channel storage expansion enclosures. You must upgrade to EXP710 storage expansion enclosures or use EXP810 storage expansion enclosures.
- DS4300 Turbo storage subsystems do not support DS4000 EXP500 fibre channel storage expansion enclosures.
- DS4100 storage subsystems do not support the FC/SATA Intermix premium feature.

For host OS-specific limitations, see the appropriate chapter for your host operating system.

## Storage subsystem management methods

The storage management software provides the following two methods for managing storage subsystems:

### In-band (host-agent) management method

Using this method, you manage the storage subsystems through the fibre channel I/O path to the host.

### Out-of-band (direct) management method

Using this method, you manage the storage subsystems directly over the network through the Ethernet connection to each controller.

The management methods are described in the next sections.

## In-band (host-agent) management method

When you use the in-band management method, you manage the storage subsystems through the fibre channel I/O path to the host.

The management information can be processed by the host or passed to the storage management station through the network connection. Figure 1 shows the in-band management method.

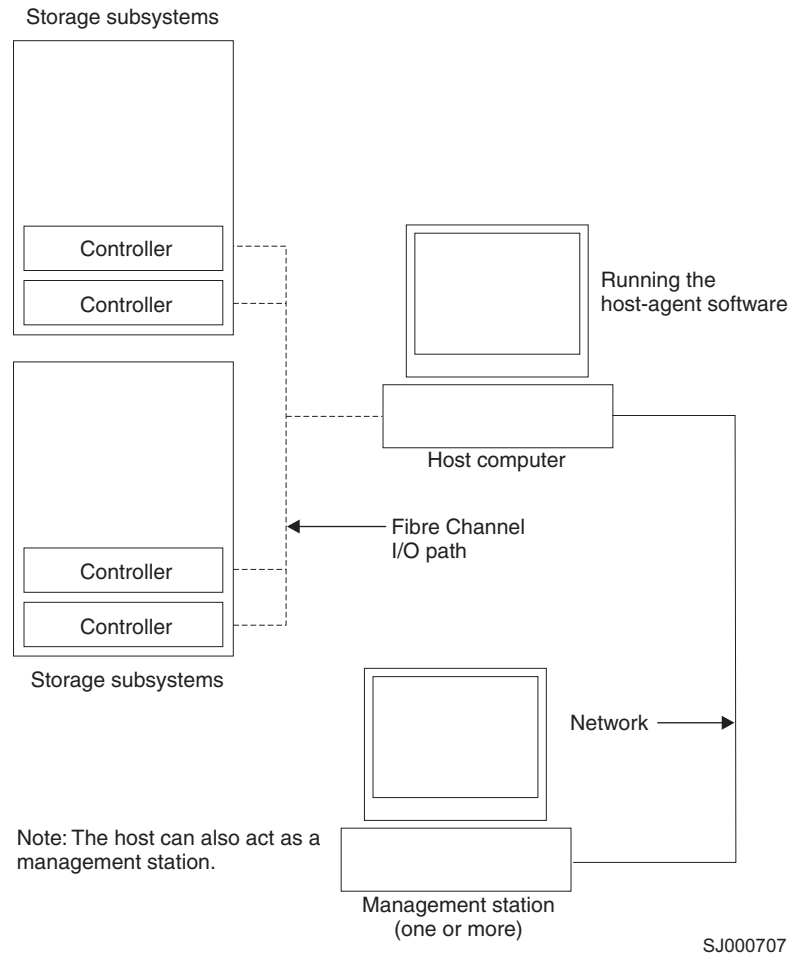

Figure 1. In-band managed storage subsystems

### Restrictions:

- If both fibre channel connections to the controllers are lost, the SMclient software cannot be accessed for problem determination.
- In-band management is not supported with controller firmware version 5.42.xx.xx.

**In-band management method advantages:** Using the in-band management method provides the following advantages:

- You do not need to run Ethernet cables to the controllers.
- You do not need a Dynamic Host Configuration Protocol (DHCP) bootstrap protocol (BOOTP) server to connect the storage subsystems to the network.
- You do not need to configure the controller network (as described in the installation chapters for each operating system).

- When adding devices, you need to specify a host name or Internet Protocol (IP) address for the host only, not for the individual controllers in a storage subsystem. Storage subsystems that are attached to the host are automatically discovered.

***In-band management method disadvantages:*** Using the in-band management method has the following disadvantages:

- If both fibre channel connections to the controllers are lost, the SMclient software cannot be accessed for problem determination.
- Unlike out-of-band management, in which the fibre channel connections are dedicated for I/O, in-band management uses the fibre channel for both I/O and status reporting. Therefore, in-band management uses more bandwidth on the fibre channel than out-of-band management, and this can have an impact on performance.
- You are limited to configuring one less LUN than the maximum number allowed by the operating system and host adapter that you are using.
- The host-agent requires a special logical drive, called an *access volume*, to communicate with the controllers in the storage subsystem.

**Important:** The access volume uses one of the LUNs. If your host already has the maximum number of LUNs configured, either use the out-of-band management method or give up a LUN for use as the access volume. For information about your specific configuration, see the appropriate chapter in this document for your operating system environment.

### **Out-of-band (direct) management method**

When you use the out-of-band (direct) management method, you manage storage subsystems directly over the network through the Ethernet connection to each controller.

To manage the storage subsystem through the Ethernet connections, you must define the IP address and host name for each controller and attach a cable to the Ethernet ports on each of the storage subsystem controllers. Figure 2 on page 11 shows the out-of-band management method.

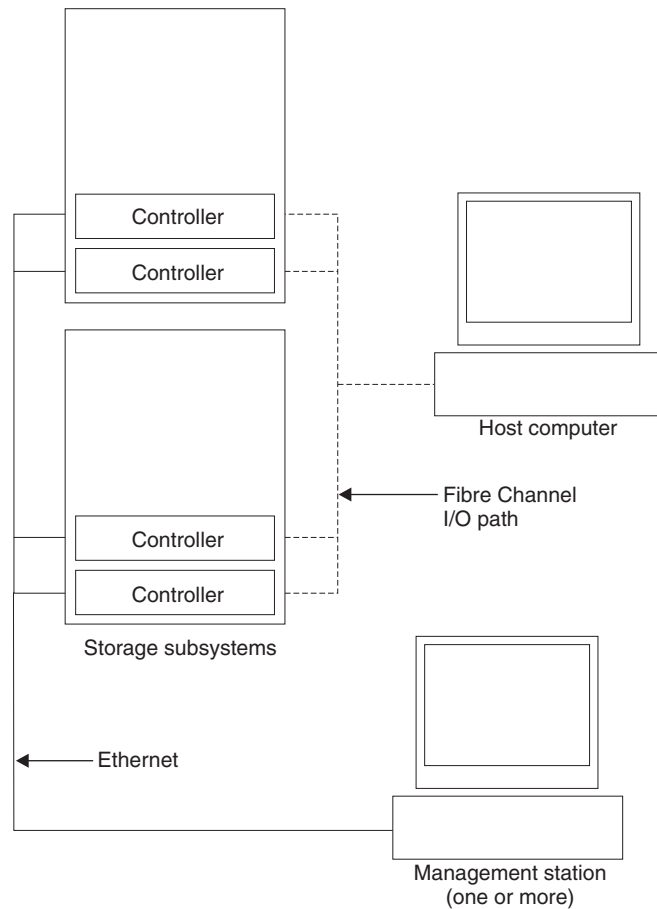

SJ000708

Figure 2. Out-of-band managed storage subsystems

If you use the out-of-band management method, see “Setting up IP addresses for DS4000 storage controllers” on page 13.

**Out-of-band management method advantages:** Using the out-of-band management method provides the following advantages:

- Unlike in-band management, which uses the fibre channel connections for both I/O and status reporting, out-of-band management dedicates the fibre channel for I/O only. Therefore, out-of-band management can result in higher performance than host-agent management.
- Because status reporting is conducted over Ethernet connections, the SMclient software can be accessed for problem determination if both fibre channel connections to the controllers are lost.
- The Ethernet connections to the controllers enable a storage management station running the SMclient software to manage storage subsystems that are connected to a host.

**Out-of-band management method disadvantages:** Using the out-of-band management method has the following disadvantages:

- It requires two Ethernet cables to connect both storage subsystem controllers to the network.
- When you configure IP addresses for new devices, you must either assign a static IP address or host name for each controller, or place the devices on a network with a DHCP or BOOTP server.

- Other network preparation tasks might be required. For more information, see the system installation guide for your network server.

### **Reviewing a sample network**

Figure 3 on page 13 shows an example of a network that contains both an out-of-band storage subsystem (Network A) and an in-band managed storage subsystem (Network B).

**Out-of-band-managed storage subsystem:** Network A is an out-of-band-managed storage subsystem. Network A contains the following components:

- A DHCP or BOOTP server
- A network management station (NMS) for Simple Network Management Protocol (SNMP) traps
- A host that is connected to a storage subsystem through a fibre-channel I/O path
- A management station that is connected by an Ethernet cable to the storage subsystem controllers

**Note:** If the controllers, static IP addresses, or default IP addresses are used, you do not need to setup the DHCP/BOOTP server.

**In-band storage subsystem:** Network B is an in-band-managed storage subsystem. Network B contains the following components:

- A host that is connected to a storage subsystem through a fibre-channel I/O path
- A management station that is connected by an Ethernet cable to the host computer

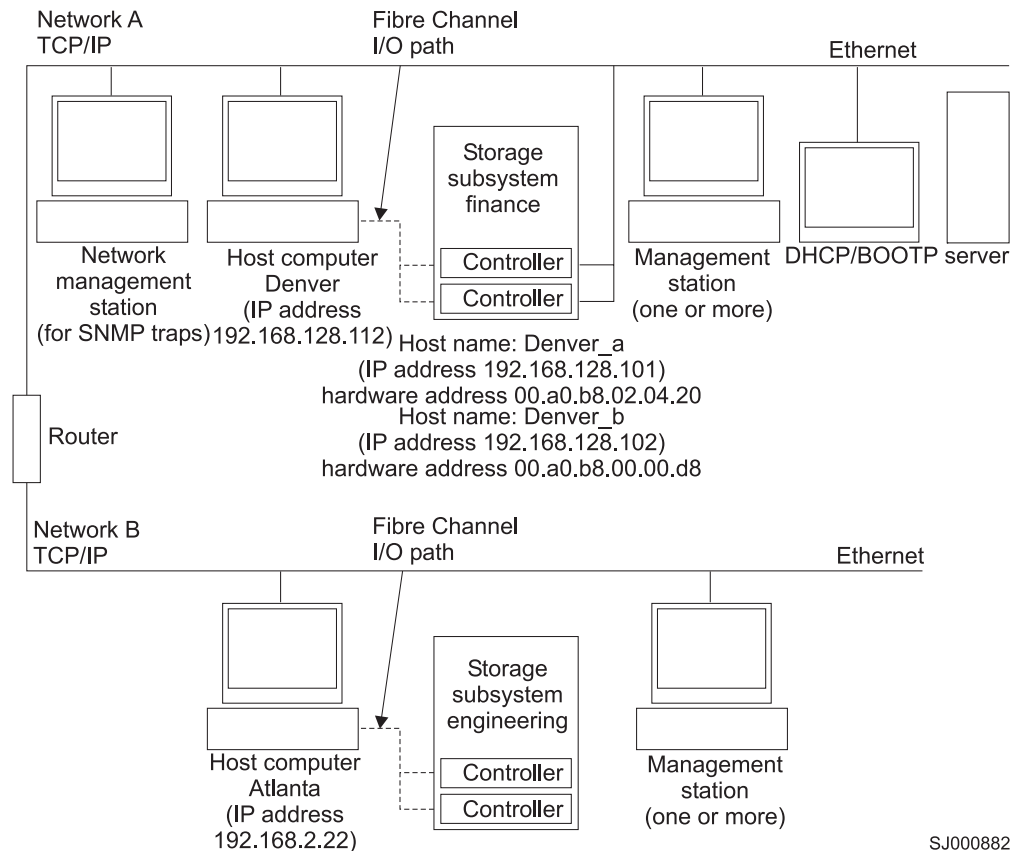

Figure 3. Sample network using both out-of-band and in-band managed storage subsystems

## Setting up IP addresses for DS4000 storage controllers

Complete the following procedures after you install SMruntime and SMclient, as described in the installation section for your host operating system.

You must set up a DHCP or BOOTP server and network with the following components:

- A DHCP or BOOTP server
- A network management station (NMS) for Simple Network Management Protocol (SNMP) traps
- A host that is connected to a storage subsystem through a fibre-channel I/O path
- A management station that is connected by an Ethernet cable to the storage subsystem controllers

**Note:** You can avoid DHCP/BOOTP server and network tasks by assigning static IP addresses to the controller. If you do not wish to assign static TCP/IP addresses with the DS4000 Storage Manager, using the DS4000 default TCP/IP addresses, see the IBM support Web site at:

[www.ibm.com/pc/support/](http://www.ibm.com/pc/support/)

Refer to Retain Tip # H171389 Unable To Setup Networking Without DHCP/BOOTP.

## Setting up the DHCP/BOOTP server and network

Complete the following steps to set up the DHCP/BOOTP server and network:

1. Get the MAC address from each controller blade.
2. Complete whichever of the following steps is appropriate for your server:
  - On a DHCP server, create a DHCP record for each of the MAC addresses. Set the lease duration to the longest time possible.
  - On a BOOTP server, edit the bootptab file to add in the entries that associate the MAC address tab with the TCP/IP address.
3. Connect the DS4000 storage subsystem Ethernet ports to the network.
4. Boot the DS4000 storage subsystem.

When you are finished, complete the steps in the next section, “Steps for assigning static TCP/IP addresses to the DS4000 controllers.”

## Steps for assigning static TCP/IP addresses to the DS4000 controllers

Complete the following steps to assign static TCP/IP addresses to the DS4000 storage subsystem controllers, using default TCP/IP addresses that are assigned to the DS4000 storage subsystem controllers during manufacturing:

1. Make a direct management connection to the DS4000 storage subsystem, using the default TCP/IP addresses:
  - **Controller A:** 192.168.128.101
  - **Controller B:** 192.168.128.102
2. Start SMclient. The Enterprise Management window opens.
3. In the Enterprise Management window, click on the name of the default storage subsystem. The Subsystem Management window opens.
4. In the Subsystem Management window, right-click the controller icon and select **Change** → **Network Configuration** in the pull-down menu. The Change Network Configuration window opens.
5. In the Change Network Configuration window, click on the Controller A and Controller B tabs and type the new TCP/IP addresses in their appropriate fields. Click **OK**.
6. Close the Subsystem Management window, wait five minutes, then delete the default DS4000 storage subsystem entry in the Enterprise Management window.
7. Add a new storage subsystem entry in the Enterprise Management window, using the new TCP/IP address.

**Note:** To manage storage subsystems through a firewall, configure the firewall to open port 2463 to TCP data.

## DS4000 Storage Manager performance planning

DS4000 storage systems provide a high degree of flexibility to meet today's demanding storage applications. As such, care should be taken to plan configurations that meet specific application performance requirements.

Like most storage vendors, IBM publishes data sheets and specifications for the capabilities of the storage subsystem. These are intended for use as reference points for raw capabilities, but do not necessarily imply that actual performance specifications will be achieved for all configurations and operating environments. Many factors that are external to the DS4000 storage subsystem, such as server processor and memory, host bus adapters, command queue depth settings, and I/O size, can impact performance.



You must plan the configuration and setup of the DS4000 for your operating environment. If proper planning is not performed, poor performance can result, such as low throughput or high disk latencies (response times).

If your system uses controller firmware versions 5.4x.xx.xx or later, you can create storage partitions with greater than 32 logical drives (up to 256). Take this factor into account during configuration planning. Depending on the I/O load requirements, it might be beneficial to spread volumes out on multiple partitions, if your operating system allows it.

**Note:** Not all operating system environments can support 256 logical drives per partition. See Table 4:

*Table 4. Maximum number of logical drives per partition*

Operating system	Maximum number of LUNs per partition
AIX	256
HP-UX 11.0	32
HP-UX 11.i,	128
HP-UX 11v2	128
Solaris 8 and 9	256 with DMP 32 with RDAC
SUSE Linux Enterprise Server 9	256
Red Hat Enterprise Linux 3	256
Red Hat Enterprise Linux 4	256

The following example shows three possible configurations that have more than 32 logical drives.

### Performance planning: Configuration examples

If your system is running DS4000 controller firmware version 05.4.xx.xx or later, you can configure all 64 logical disks into one storage partition with two HBAs. You can also configure 256 logical disks into one partition with two HBAs. See Table 5.

**Note:** Systems running DS4000 controller firmware version 05.3x.xx.xx or earlier require two storage partitions, each with 32 logical drives and four HBAs, to connect 64 logical disks to a host.

*Table 5. Examples of possible configurations with more than 32 logical drives*

Configuration number	DS4000 firmware version	HBAs	Storage partitions	Logical drives
1	05.3.xx.xx	4	2	64
2	05.4.xx.xx	2	1	64
3	05.4.xx.xx or 06.1x.xx.xx	2	1	256

You might expect the following performance results with the configurations listed in Table 5:

- Configuration 1 might perform better than Configuration 2, which has more logical drives per storage partition.
- Depending on the application, Configuration 3 might perform poorly because of the large number of logical drives per partition. Applications that do not require

frequent use of (or connectivity to) many logical drives might respond quite well and meet performance expectations. Other applications, such as those that require simultaneous access to all volumes over extended periods of time, will likely experience lower throughput and high latencies on the individual logical drives.

For excellent information about how to plan your configuration, see the following documents:

- *IBM System Storage DS4000 Storage Manager Concepts Guide*
- *IBM TotalStorage: DS4000 Best Practices Guide*

## **DS4000 Storage Manager premium features**

DS4000 Storage Manager supports the following premium features, which are separately available for purchase from IBM or an IBM Business Partner:

### **Copy Services**

The following copy services are available with Storage Manager 10.10:

- FlashCopy®
- VolumeCopy
- Enhanced Remote Mirror Option

For more detailed information about the copy services features, see the following publications:

- *IBM System Storage DS4000 Storage Manager Copy Services User's Guide*
- *IBM System Storage DS4000 Storage Manager Concepts Guide*

### **Storage Partitioning**

Storage Partitioning is standard on all DS4000 storage subsystems that are supported by DS4000 controller firmware versions 06.10.xx.xx–07.10.xx.xx. For more information about Storage Partitioning, see the “Storage partitioning overview” on page 40.

### **FC/SATA Intermix premium feature**

The IBM System Storage DS4000 Fibre Channel and Serial ATA Intermix premium feature supports the concurrent attachment of fibre channel and SATA storage expansion enclosures to a single DS4000 controller configuration.

For more detailed information about the FC/SATA Intermix premium features, see the following publication:

- *IBM System Storage DS4000 Fibre Channel and Serial ATA Intermix Premium Feature Installation Overview.*

### **FC/SATA Intermix premium feature**

The IBM System Storage DS4000 Fibre Channel and Serial ATA Intermix premium feature supports the concurrent attachment of fibre channel and SATA storage expansion enclosures to a single DS4000 controller configuration.

This Intermix premium feature enables you to create and manage distinct arrays that are built from either fibre channel disks or SATA disks, and allocate logical drives to the appropriate applications using a single DS4000 storage subsystem.

For important information about using the Intermix premium feature, including configuration, firmware versions required for specific Intermix configurations, and

setup requirements, see the *IBM System Storage DS4000 Fibre Channel and Serial ATA Intermix Premium Feature Installation Overview*.

Please see your IBM representative or reseller for information regarding future DS4000 storage subsystem support for the FC/SATA Intermix premium feature.

**Enabling the DS4000 FC/SATA Intermix premium feature:** Storage Manager 10.10 supports the DS4000 FC/SATA Intermix premium feature with all 06.1x.xx.xx–07.10.xx.xx controller firmware versions. Depending on the level of controller firmware installed on your storage subsystem, you need to follow different procedures to enable the premium feature, which is done using a premium feature key. To install the DS4000 FC/SATA Intermix Premium Feature Key, follow the instructions provided in the *IBM System Storage DS4000 Fibre Channel and Serial ATA Intermix Premium Feature Installation Overview*

**DS4000 controller firmware version 07.10.xx.xx**

On storage subsystems (DS4800 and DS4700) using DS4000 controller firmware version 07.10.xx.xx, the DS4000 FC/SATA Intermix premium feature is enabled using a premium feature key.

**DS4000 controller firmware version 06.23.xx.xx**

On storage subsystems using DS4000 controller firmware versions 06.23.xx.xx and later, the DS4000 FC/SATA Intermix premium feature is enabled using a premium feature key.

**DS4000 controller firmware version 06.19.xx.xx**

On storage subsystems (only DS4300 and DS4500) using DS4000 controller firmware version 06.19.xx.xx, the DS4000 FC/SATA Intermix premium feature is enabled using a premium feature key.

**DS4000 controller firmware version 06.16.xx.xx**

On storage subsystems using DS4000 controller firmware versions 06.16.xx.xx and later, the DS4000 FC/SATA Intermix premium feature is enabled using a premium feature key.

**DS4000 controller firmware versions 06.12.xx.xx and later**

On storage subsystems using DS4000 controller firmware versions 06.12.xx.xx and later, the DS4000 FC/SATA Intermix premium feature is enabled using a premium feature key.

**DS4000 controller firmware version 06.10.xx.xx**

On storage subsystems using DS4000 controller firmware version 06.10.xx.xx, the DS4000 FC/SATA Intermix premium feature is enabled using an NVSRAM file.

Download the appropriate NVSRAM version to enable the DS4000 FC/SATA Intermix premium feature.

**Upgrading DS4000 controller firmware on systems with FC/SATA Intermix already enabled**

If you are currently using DS4000 controller firmware 06.10.xx.xx and want to upgrade to 06.12.xx.xx or a later version, and you already have the FC/SATA Intermix premium feature enabled on your subsystem, you need to complete the steps in this section.

Complete the following steps to upgrade the controller firmware to 06.12.xx.xx or later:

1. Upgrade the controller firmware and NVSRAM to 06.12.xx.xx or later version.

- Note:** After the firmware is upgraded, the recovery guru will display the error “premium feature out-of-compliance.” The premium feature that is out-of-compliance is the DS4000 FC/SATA Intermix premium feature. You will not be able to create any arrays or logical drives or modify the LUNs until after you complete step 2.
2. Enable the DS4000 FC/SATA Intermix premium feature using the premium feature key file. Use the instructions in the DS4000 FC/SATA Intermix premium feature activation card to generate the premium feature key file. This restores the DS4000 subsystem to full functionality.

## Enabling premium features

You must perform the following tasks to enable a premium feature on your storage subsystem:

- “Obtaining the feature enable identifier”
- “Generating the feature key file”
- “Enabling the premium feature”
- “Verifying that the premium feature is enabled” on page 19

To obtain the storage subsystem premium feature identifier string, ensure that your controller unit and storage expansion enclosures are connected, powered on, and managed using the SMclient. Continue with the next section.

**Obtaining the feature enable identifier:** Each storage subsystem has its own unique feature enable identifier. This identifier ensures that a particular feature key file is applicable only to that storage subsystem. Complete the following steps to obtain the feature enable identifier:

1. Click **Start** → **Programs** → **Storage Manager 10 Client**. The Enterprise Management window opens.
2. In the Enterprise Management window, double-click the storage subsystem for which you want to enable the premium feature. The Subsystem Management window opens for the selected storage subsystem.
3. In the Subsystem Management window, click **Storage Subsystem** → **Premium Features** → **List**. The List Premium Features window opens and displays the feature enable identifier.
4. Record the feature enable identifier.
5. Close the List Premium Features window.
6. Continue to next section, “Generating the feature key file.”

**Note:** To check the status of an existing premium feature, select **Storage Subsystem** → **Premium Features** → **List** from the pull-down menu.

**Generating the feature key file:** You can generate the feature key file by using the Premium Feature Activation tool that is located at the following Web site:

[www-912.ibm.com/PremiumFeatures/jsp/keyInput.jsp](http://www-912.ibm.com/PremiumFeatures/jsp/keyInput.jsp)

1. Complete the steps in the Web site. Feature key file is e-mailed to you.
2. On your hard drive, create a new directory that you can find easily. (For example, name the directory **FlashCopy feature key**.)
3. Save the feature key file in the new directory.

**Enabling the premium feature:** In the Storage Manager subsystem management window:

1. In the menu, click **Premium Features → Enable**.
2. Browse to the appropriate key file in the directory you saved it to in the previous task, “Generating the feature key file” on page 18.
3. Click **OK**.
4. Confirm that the premium feature is enabled. See the next section, “Verifying that the premium feature is enabled.”

*Verifying that the premium feature is enabled:* Perform the following steps to see a list of those premium features that are enabled on your storage subsystem:

1. In the Subsystem Management window, click **Storage Subsystem → Premium Features → List**.

The List Premium Features window opens (see Figure 4).

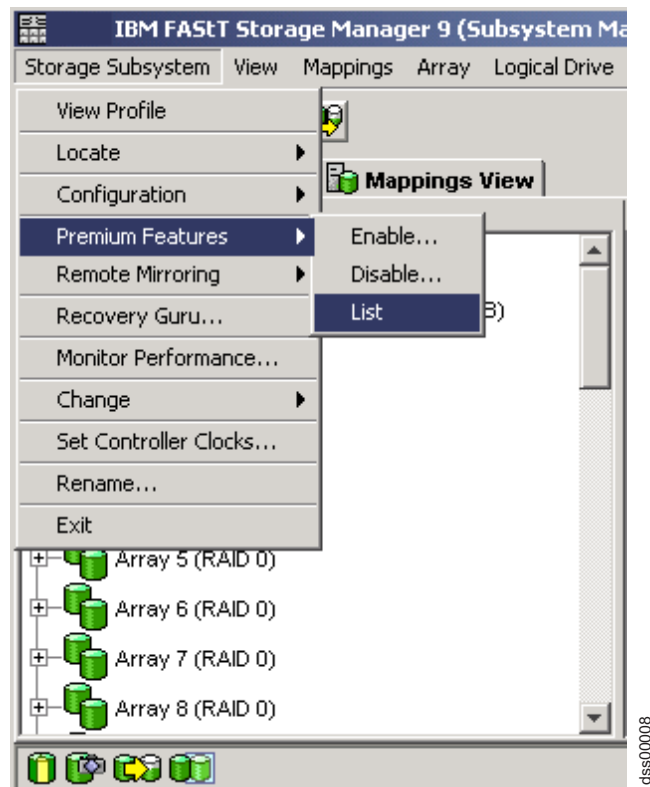

Figure 4. Listing premium features

The dialog lists the following items:

- The premium features that are enabled on the storage subsystem
- The feature enable identifier

2. Click **Close** to close the window.

**Disabling premium features:** In normal system operations, you do not need to disable the premium features. However, if you want to disable a premium feature, make sure that you have the key file or the IBM DS4000 premium feature entitlement card with the premium feature activation code for generating the key file. You need this key file to re-enable the premium feature at a later time.

Perform the following steps to disable a premium feature on the storage subsystem:

1. In the Subsystem Management window, click **Storage Subsystem → Premium Features → Disable**.

The Disable Premium Feature window opens, listing all the premium features that are enabled.

2. Select one item in the list, and then click **OK**.

A confirmation dialog displays that states that disabling a premium feature is not recommended.

3. Click **Yes**.

The Working dialog displays while the feature is being disabled. When the feature has been disabled, the Working dialog closes.

**Notes:**

1. If you want to enable the premium feature in the future, you must reapply the Feature Key file for that feature.
2. You can disable the Remote Mirror Option without deactivating the feature. If the feature is disabled but activated, you can perform all mirroring operations on existing remote mirrors. However, when the feature is disabled you cannot create any new remote mirrors. For more information about activating the Remote Mirror Option, see the *DS4000 Storage Manager Copy Services Guide* or see “Using the Activate Remote Mirroring Wizard” in the Storage Manager online help.
3. If a premium feature becomes disabled, you can access the Web site and repeat this process.

For any additional assistance, contact your local IBM service provider. Make sure you have available the information listed in “Enabling the premium feature” on page 18.

---

## **DS4000 hardware and firmware requirements for AIX, HP-UX, Solaris, and Linux on POWER**

Table 6 on page 21 lists the DS4000 EXP storage expansion enclosures and other hardware that are supported with DS4000 Storage Manager. Check the Storage Manager readme file for your specific operating system to determine the latest supported firmware versions for the devices listed in the table.

**Note:** See “Finding the Storage Manager readme files online” on page 24 for steps that will help you find the readme files on the Web. (If you do not have access to the Web, you can check the Storage Manager readme file that is located on your DS4000 Installation CD.)

Table 6. Supported DS4000 expansion enclosures and other hardware for AIX, HP-UX, Solaris, and Linux on POWER systems

Hardware	Product Name	Model	
<b>Storage Expansion Enclosure</b>	IBM System Storage DS4000 EXP810 Storage Expansion Enclosure	1812-81A/H HP-UX only supports models 1812-81A/H	
	IBM TotalStorage DS4000 EXP100 SATA Storage Expansion Enclosure	1710-10U or 10X	
	IBM TotalStorage DS4000 EXP710 Fibre Channel Storage Expansion Enclosure	1740-710	
	IBM TotalStorage DS4000 EXP700 Fibre Channel Storage Expansion Enclosure	1740-1RU or 1RX	
	IBM TotalStorage DS4000 EXP500 Fibre Channel Storage Expansion Enclosure	3560-1RU or 1RX	
	IBM System Storage DS4000 EXP420 SATA Storage Expansion Enclosure	1812-8VA/H	
<b>AIX Host Bus Adapters</b>	IBM HA Emulex LP7000	FC 6227	
	IBM HA Emulex LP9000	FC 6228	
	IBM HA Emulex LP9802-F2	FC 6239	
	IBM HA Emulex LP9002	FC 6226 FC 0611 FC 0612	
	IBM HA Emulex LP9802	FC 6239 FC 0625 FC 0626	
	IBM HA Emulex LP10000 (can also be in eClipz server) (AIX 5.2 and 5.3 only)	FC 5716 FC 1977 FC 1957	
	IBM HA Emulex LP11000 (AIX 5.2 and 5.3 only)	42D0405 FC 5758 FC 1905	
	IBM HA Emulex LP11002 (AIX 5.2 and 5.3 only)	42D0407 FC 5759 FC 1910	
	IBM HA Emulex LPe11000 (eClipz server only)	42C2069 FC 5773	
	IBM HA Emulex LPe11002 (eClipz server only)	42C2071 FC 5774	
	BladeCenter blades JS20, JS21		
	IBM HA Emulex LP1105BC (JS21 only)	39Y9186 FC 2925	
	IBM HA Emulex LP1105BCv (JS21 only)	43W6859	
	QLogic 4Gb CFFv	41Y8527 FC 2970	
	QLogic 4Gb SFF	26R0890 FC 1577	
	QLogic 4Gb StFF	26R0884 FC 1597	

Table 6. Supported DS4000 expansion enclosures and other hardware for AIX, HP-UX, Solaris, and Linux on POWER systems (continued)

Hardware	Product Name	Model
<b>HP-UX Host Bus Adapters</b>	HP FC Adapter for HP-UX 11.0	A5158A, A6795A
	HP FC Adapter for HP-UX 11i	A5158A, A6795A
<b>Solaris Host Bus Adapters</b>	JNI FC Adapter	FCE-6410-N 33 Mhz
	JNI FC Adapter	FCE2-6412 66 Mhz 64 bit
	JNI FC Adapter	FCE-6460-PCI 64 bit
	JNI FC Adapter	FCE-1473 S-bus 64 bit
	JNI FC Adapter	FCC2-6562
	JNI FC Adapter	FCX-6562
	JNI FC Adapter	FCCX2-6562
	QLogic Adapter	234x
	Emulex Adapter	LP9001
	Emulex Adapter	LP9802
	Emulex Adapter	LP10000



Table 6. Supported DS4000 expansion enclosures and other hardware for AIX, HP-UX, Solaris, and Linux on POWER systems (continued)

Hardware	Product Name	Model	
<b>Linux Host Bus Adapters</b>  Please check the DS4000 Storage Manager readme file for Linux on POWER for additional supported HBAs.	IBM HA Emulex LP9000	FC 6228	
	IBM HA Emulex LP9002-F2	FC 6239	
	IBM JS20 Fibre Channel daughter card 73P6112	FC 1.06	
	IBM HA Emulex LP9802-F2	FC 6239	
	IBM HA Emulex LP11002	FC 5759	
	IBM HA Emulex LP9002	FC 6226 FC 0611 FC 0612	
	IBM HA Emulex LP9802	FC 6239 FC 0625 FC 0626	
	IBM HA Emulex LP10000 (can also be in eClipz server)	FC 5716 FC 1977 FC 1957	
	IBM HA Emulex LP11000	42D0405 FC 5758 FC 1905	
	IBM HA Emulex LP11002	42D0407 FC 5759 FC 1910	
	IBM HA Emulex LPe11000 (eClipz server only)	42C2069 FC 5773	
	IBM HA Emulex LPe11002 (eClipz server only)	42C2071 FC 5774	
	BladeCenter blades JS20, JS21		
	IBM HA Emulex LP1105BC (JS21 only)	39Y9186 FC 2925	
	IBM HA Emulex LP1105BCv (JS21 only)	43W6859	
	QLogic 4Gb CFFv	41Y8527 FC 2970	
QLogic 4Gb SFF	26R0890 FC 1577		
QLogic 4Gb StFF	26R0884 FC 1597		

Table 6. Supported DS4000 expansion enclosures and other hardware for AIX, HP-UX, Solaris, and Linux on POWER systems (continued)

Hardware	Product Name	Model
Switches	IBM TotalStorage SAN Switch	2109-S08 2109-S16
	IBM TotalStorage SAN Switch	2109-F16
	IBM TotalStorage SAN Switch	2109-M12
	IBM TotalStorage SAN Switch	2109-F32
	IBM TotalStorage SAN Switch	2109-F08
	McData Switch	2032-064 2032-140
	McData Switch	2031-016
	McData Switch	2031-216 2031-224
	CNT Switch	2042-001
	Cisco Switch	2062-D01 2062-D07 2062-T07

**See also:**

In addition to the readme file, for up-to-date information please refer to the following Web pages:

**Switches**

[www.ibm.com/servers/storage/support/san/index.html](http://www.ibm.com/servers/storage/support/san/index.html)

**Interoperability**

[www-1.ibm.com/servers/storage/disk/ds4000/interop-matrix.html](http://www-1.ibm.com/servers/storage/disk/ds4000/interop-matrix.html)

For important information about using the DS4000 EXP100 SATA storage expansion enclosure, see the *IBM TotalStorage DS4000 EXP100 Storage Expansion Enclosure Installation and User's Guide*.

**Important for HP-UX:** IBM strongly recommends that you install controller firmware and NVSRAM versions 06.12.xx.xx or later. These versions contain fixes that are not available with earlier versions.

---

## Finding the Storage Manager readme files online

To find the latest DS4000 Storage Manager readme file online, complete the following steps:

1. For the most recent Storage Manager readme files for your operating system, see the following Web site:  
[www-1.ibm.com/servers/storage/support/disk/](http://www-1.ibm.com/servers/storage/support/disk/)
2. Click the link for your storage subsystem.
3. When the subsystem page opens, click the **Download** tab.
4. When the download page opens, click the link for Storage Manager.
5. When the next page opens, click the **Storage Mgr** tab. A table displays.

6. In the table, find the entry for IBM DS4000 Storage Manager for your operating system, and click the corresponding link under the **Current version and readmes** column.



---

## Chapter 2. Installing and configuring storage management software on AIX host systems

This chapter provides the following information for AIX operating systems:

- “AIX restrictions” on page 28
- “Installing DS4000 Storage Manager” on page 29
- “Configuring storage subsystems” on page 35
- “Creating storage partitions” on page 40
- “Creating direct and SAN-attached configurations” on page 44
- “Installing the RDAC failover driver” on page 45
- “Identifying devices on AIX hosts” on page 47
- “Verifying the installation and configuration” on page 50
- “Viewing and setting Object Data Manager (ODM) attributes” on page 60
- “Additional AIX configuration information” on page 68
- “Replacing hot swap HBAs” on page 72
- “Resolving disk array errors” on page 79
- “Redistributing logical drives in case of failure” on page 81

---

### Hardware, software and host system requirements

This section provides information about the hardware and software requirements for the AIX host system.

**Note:** For the latest installation requirements and user information about Storage Manager, AIX file sets, and hardware components, see the Storage Manager readme file for AIX that is located on the DS4000 Installation CD. You can also find the readme file online, as described in “Finding the Storage Manager readme files online” on page 24.

### AIX system requirements

This section lists the minimum hardware and software requirements for an AIX host in a DS4100, DS4200 Express, DS4300, DS4400, DS4500, DS4700, or DS4800 storage subsystem that is managed by DS4000 Storage Manager.

**Note:** For more information about using AIX with Series p and POWER servers, see the Series p and AIX Information Center at the following Web site:

[publib.boulder.ibm.com/infocenter/pseries/index.jsp?](http://publib.boulder.ibm.com/infocenter/pseries/index.jsp)

#### Hardware requirements

The following hardware is required at minimum:

Any RS/6000®, RS6000 SP™ or IBM @server, Series p™, or POWER server that supports FC 6228, FC 6239, FC 5716, FC 5758, or FC 5759 host bus adapters

#### Software requirements

The following operating system software is required:

- AIX 5.2, 5.3 or Virtual I/O Server
- The required minimum AIX file sets, associated with AIX RDAC driver installations, that are listed in the Storage Manager readme file for AIX.

**Note:** For information about Virtual I/O Server requirements, see the following Web site: <http://www14.software.ibm.com/webapp/set2/sas/f/vios/home.html>

---

## AIX restrictions

The following restrictions apply to AIX configurations:

### SAN and connectivity restrictions

- AIX hosts can support multiple host bus adapters (HBAs) and DS4000 devices; however, there is a restriction on the number of HBAs that can be connected to a single DS4000 storage subsystem. You can configure up to two HBAs per partition and up to two partitions per DS4000 storage subsystem. Additional HBAs can be added for additional DS4000 storage subsystems and other SAN devices, up to the limits of your specific subsystem platform.
- AIX imposes the following limitations on disk volume sizes:
  - 1 TB, on 32-bit 4.3.3, 5.1, or 5.2
  - 2 TB, on 64-bit 5.1 (1 TB for anything reliant on boot info)
  - 2 TB, on 64-bit 5.2 (2 TB when using LVM bad block relocation)
  - greater than 2 TB, on 64-bit 5.2 and 5.3 with controller firmware 07.10.xx.xx and above

Even where larger volumes are supported, the AIX boot logical volume must reside within the first 2 TB of the volume. Hardware devices or 3rd party software may further limit volume sizes. Customers should contact their hardware or software vendor for additional information.

- Direct-attach configurations are restricted to single-initiator configurations only. You can make only one connection to each minihub on a DS4500 storage subsystem.

**Note:** DS4800, DS4700, DS4300, DS4200, and DS4100 storage subsystems do not have minihubs.

- Single-switch configurations are allowed, but each HBA and DS4000 controller combination must be in a separate SAN zone.
- Other storage devices, such as tape devices or other disk storage, must be connected through separate HBAs and SAN zones.
- Single HBA configurations are allowed, but each single HBA configuration requires that both controllers in the DS4000 be connected to the HBA, either through a switch or daisy-chain (direct-attach only). If they are connected through a switch, both controllers must be within the same SAN zone as the HBA.

**Attention:** Having a single HBA configuration can lead to loss of access data in the event of a path failure.

**Note:** DS4800, DS4700, DS4300, DS4200, and DS4100 storage subsystems do not support daisy-chain configurations.

### Restrictions when booting up your system

- When you boot your system from a DS4000 device, both paths to the DS4000 storage subsystem must be up and running.
- The system cannot use path failover during the AIX boot process. Once the AIX host has started, failover operates normally.

**Recommendation:** It is recommended that you do not boot your system from a SATA device.

#### Partitioning restrictions

- The maximum number of partitions per AIX host, per DS4000 storage subsystem, is two.

**Exception:** With DS4800 and DS4700 Model 72, the maximum number of partitions for a host is four per storage subsystem.

- All logical drives that are configured for AIX must be mapped to an AIX host group.

**Note:** If you are using the default host group, ensure that the default host type is AIX.

For more information, see “Creating storage partitions” on page 40.

- On each controller, you must configure at least one LUN with an ID between 0 and 31 that is not a UTM or access logical drive.

#### Interoperability restrictions

- Concurrent download is not supported with some controller firmware versions, such as 06.14.xx.xx or 06.15.xx.xx. Please see the latest Storage Manager readme file for AIX to find out which firmware versions support concurrent download.
- DS4100 and DS4300 *single-controller* storage subsystems are not supported with AIX hosts. (DS4100 dual-controller and DS4300 Base and Turbo dual-controller storage subsystems are supported.)
- EXP700 storage expansion enclosures are not supported with DS4800.

---

## Installing DS4000 Storage Manager

### Preparing for software installation

Before you install the DS4000 software, here are some additional items you may need to assemble in preparation for the installation.

- For the AIX operating system, make certain you are running the OS-required maintenance level. (Check the readme.txt file for lists of required maintenance levels, as well as for any additional fixes.)
- HBA drivers
- The most up-to-date controller firmware for your particular storage subsystem (see Table 2 on page 2 to determine the firmware version you need)
- IP addresses for RAID controllers (for out-of-band management, only)
- Additional documentation for switches and HBAs, if needed
- Appropriate host CD for your operating system, which includes the most up-to-date DS4000 software and controller firmware for your particular storage subsystem

Depending on the DS4000 model you order, your DS4000 will ship with either the Microsoft® Windows host software attachment kit or with your choice of host software kits (Windows, AIX, Linux, NetWare, SUN Solaris, HP-UX, or Linux on POWER). The host software kit grants you permission to attach host servers using the appropriate operating system for the DS4000. The kit includes the most up-to-date DS4000 software and controller firmware for your particular storage subsystem.

For the latest controller firmware, check the IBM support Web site for DS4000 storage products.

<http://www.ibm.com/servers/storage/support/disk/>

**Note:** If you install Storage Manager 10.10 using the Storage Manager Installation Agent, the installer will display an "IBM System Storage DS4000/FAST Storage Manager" splash screen with a drop down menu. From this drop down menu you can select a language option. (Language selection is optional if you are performing an English language installation.) The language option you select will determine the language version of the License Agreement that will be displayed. Once you have selected a language, click the **OK** button. The next screen will display the License Agreement in the preferred language. Select "I accept the terms of the License Agreement," and click **Next** to continue with the installation

You can install all of the DS4000 Storage Manager software packages automatically by using the Storage Manager installation wizard, or you can install each package manually. This section contains the following procedures:

- "Installing Storage Manager using the installation wizard"
- "Installing Storage Manager packages manually" on page 31 (original method)

## Failover drivers

An AIX host system requires the *AIX Redundant Disk Array Controller (RDAC)* failover driver for fibre channel path redundancy.

The failover driver monitors I/O paths. If a component failure occurs in one of the fibre channel paths, the failover driver reroutes all I/O to another path.

**Note:** The AIX RDAC driver files are not included on the DS4000 Storage Manager installation CD. To install them, you must download the files from the Web site listed in "Installing the RDAC failover driver" on page 45 and follow the instructions you find there.

## Installing Storage Manager using the installation wizard

The DS4000 Storage Manager installation wizard installs the following software packages on the AIX host:

- SMruntime
- SMesm
- SMclient
- SMagent
- SMutil

### Requirements:

1. DS4000 Storage Manager version 10.10
2. xservices must be operational

If you are installing Storage Manager 10.10 on AIX and your system does not meet the requirements for using the wizard, does not have a graphics card installed, or if you do not want to use the wizard to install the software, you can perform the installation without a GUI by typing the `sh <installer-package-name.bin> -i console` command in the command line interface. You can also skip this section and



install the stand-alone host software packages using the procedures described in “Installing Storage Manager packages manually.” All the packages are included with the installation CD.

**Notes:**

1. If you use the wizard to install Storage Manager, you might need to increase the size of some partitions to accommodate the installation. These partitions will be identified during the installation process.
2. Do not install the software packages in the same subsystem by using both the installation wizard and the manual installation method.

Complete the following steps to install the DS4000 Storage Manager software using the installation wizard. Adjust the steps as necessary for your specific installation.

1. Download the following file from the DS4000 Storage Manager CD, or from the DS4000 support Web site, to a directory on your system:  
SMIA-AIX-10.10.xx.xx.bin
2. Open the file on your system. The Storage Manager Installation wizard’s Introduction window opens.
3. Follow the instructions in each window of the wizard. When you select the installation type, you can choose one of the following options:
  - Typical (Full) Installation—Installs all Storage Manager software packages
  - Management Station—Installs SMruntime and SMclient
  - Host—Installs SMruntime, SMagent and SMutil
  - Custom—Allows you to select which packages you want to install

**Note:** During the installation, you will see the question **Automatically Start Monitor?**. This refers to the Event Monitor service. If you want to enable automatic ESM firmware synchronization, the Event Monitor must be enabled. To enable the Event Monitor, elect **Automatically Start Monitor**. For more information, see “Automatic ESM firmware synchronization” on page 232.

**Result:** The DS4000 Storage Manager software is installed on your system.

## Installing Storage Manager packages manually

Use the following procedures, in the order listed, to install the DS4000 Storage Manager software on an AIX storage management station.

1. “Installing the client software”
2. “Installing SMagent (optional)” on page 33

### Installing the client software

For the specific installation order, see Table 3 on page 5.

**Note:** SMclient is dependent on SMruntime, which is a Java compiler for SMclient. SMruntime must be installed first.

**Prerequisites:** Before installing the software, ensure that the following conditions are met:

- The AIX host on which you are installing SMruntime meets the minimum hardware and software requirements described in “Hardware, software and host system requirements” on page 27 and <http://www14.software.ibm.com/webapp/set2/sas/f/vios/home.html>.
- The correct file sets are present on the system.

**Note:** If the file sets are not present, check the Storage Manager readme file for AIX for the minimum file set versions required for your AIX operating system. (See “Readme files and concepts” on page 1.) Then, follow the instructions in “Steps for downloading the AIX file sets” on page 46 to download them from the appropriate Web site.

- The DS4000 Storage Manager files are available in a directory on the system.

**Steps for installing SMruntime software:** Modify the commands as needed for your installation. No restart is required during the installation process.

1. Install SMruntime by typing the following command:

```
# installp -a -d /path_name  
/SMruntime.AIX-10.10.xx.xx.bff SMruntime.aix.rte
```

where *path\_name* is the directory path to the SMruntime package.

2. Verify that the installation was successful by typing the following command:

```
# ls1pp -ah SMruntime.aix.rte
```

The verification process returns a table that describes the software installation, including the install package file name, version number, action and action status. If the verification process returns an error, contact your IBM service representative.

**Steps for installing SMesm software (required if installing SMclient):** Modify the commands as needed for your installation. No restart is required during the client installation process.

1. Install SMesm by typing the following command:

```
# installp -a -d /path_name/  
SMesm.AIX-10.10.xx.xx.bff SMesm.aix.rte
```

where *path\_name* is the directory path to the SMesm package.

2. Verify that the installation was successful by typing the following command:

```
# ls1pp -ah SMesm.aix.rte
```

The verification process returns a table that describes the software installation, including the install package file name, version number, action and action status. If the verification process returns an error, contact your support representative.

**Steps for installing SMclient software:** Modify the commands as needed for your installation. No restart is required during the client installation process.

1. Install SMclient by typing the following command:

```
# installp -a -d /path_name/  
SMclient.AIX-10.10.xx.xx.bff SMclient.aix.rte
```

where *path\_name* is the directory path to the SMclient package.

2. Verify that the installation was successful by typing the following command:

```
# ls1pp -ah SMclient.aix.rte
```

The verification process returns a table that describes the software installation, including the install package file name, version number, action, and action status. If the verification process returns an error, contact your support representative.

## Installing SMagent (optional)

SMagent is required for in-band management only. It is not required for out-of-band management.

**Prerequisites:** Before installing SMagent, ensure that the following conditions are met:

- This is the AIX server that you identified as the storage management station.
- This machine meets the minimum hardware and software requirements described in .
- SMruntime has been installed.

**Steps for installing SMagent software:** Modify these commands as needed for your installation. No restart is required during the client installation process.

**Note:** The installation process adds an entry to the /etc/inittab file that starts SMagent each time the system is booted.

1. Install SMagent by typing the following command:

```
# installp -a -d /path_name/  
SMagent.AIX-10.10.xx.xx.bff SMagent.aix.rte
```

where *path\_name* is the directory path to the SMagent package.

2. Verify that the installation was successful by typing the following command:

```
# ls1pp -ah SMagent.aix.rte
```

**Starting or stopping SMagent software:** Use the following command to manually start SMagent:

```
# SMagent start
```

Use the following command to manually stop SMagent:

```
# SMagent stop
```

**Steps for installing SMutil software:** Modify the commands as needed for your installation. No restart is required during the client installation process.

1. Install SMutil by typing the following command:

```
# installp -a -d /path_name/  
SMutil.AIX-10.10.xx.xx.bff SMutil.aix.rte
```

where *path\_name* is the directory path to the SMutil package.

2. Verify that the installation was successful by typing the following command:

```
# ls1pp -ah SMutil.aix.rte
```

The verification process returns a table that describes the software installation, including the install package file name, version number, action, and action status. If the verification process returns an error, contact your support representative.

---

## SAN boot with AIX

### Assumptions

This procedure assumes the following:

- No installation is present.
- After the installation is complete, the boot and swap devices will run on a DS4000 storage subsystem.
- For specific information about disk volume sizes, see “AIX restrictions” on page 28.

### Preparing for the SAN boot procedure

Complete the following steps before you begin the installation.

1. Be familiar with the following topics:
  - How to connect to and operate an IBM Series p server
  - How to create LUNs on the DS4000 storage subsystem
  - How to set up a SAN network or direct-attached SAN storage devices, so that the configured server can access the DS4000 LUNs
  - How the AIX kernel boot process functions, and what processes and procedures are used to boot an AIX distribution for a local storage device. For more information, see the AIX 5L™ 5.3 Installation Guide.  
<http://publib.boulder.ibm.com/infocenter/pseries/v5r3/topic/com.ibm.aix.install/doc/insgdrf/insgdrf.pdf>
2. Make sure your hardware installation is complete, including all external devices. (See the documentation provided with your system for installation instructions.)
3. Verify that the fibre channel HBAs are mapped to the correct DS4000 drives using the Smclient GUI.
4. In dual-path systems, IBM recommends that you have both paths available during the SAN boot operating system installation process.
5. Ensure that the size of the boot device that you plan to use is at least 2.2 GB. Future growth potential would dictate a minimum of 18GB.
6. Ensure that you have your AIX 5.2 or AIX 5.3 operating system installation CD.

**Note:** For simplicity, the procedure described in this document assumes that the boot, root, and swap devices are all located on the same device; however, this is not a requirement for the installation.

### Steps for performing the SAN boot procedure

The installation media (source for installation) that is used in the following steps is a set of release CDs.

#### Important:

Not all of the details about installation and partitioning are documented in this procedure. To determine which packages are needed for the type of system you are installing, you must refer to your system's installation procedures.

**Note:** Complete the following steps.

1. Ensure all external devices (i.e. storage) are powered on.
2. Power on server, and insert AIX Volume 1 CD into CDROM/DVD.
3. Boot to the System Management Services menu (SMS).
4. From the SMS menu, select your installation source (CD), and boot from the AIX Volume 1 Product CD . (See your server's installation manual for detailed instructions.)
5. When the Welcome to Base Operating System Installation and Maintenance window displays, type **2** in the Choice field to select Change/Show Installation Settings and Install, and press **Enter**.
6. When the Change Method of Installation window displays, select **1** for New and Complete Overwrite, and press **Enter**.
7. When the Change Disk(s) window displays, you can change/select the destination disk for the installation. At this point, you can select the appropriate DS4000 hdisk(s) and deselect any other drives (for example, SCSI).
8. When you have finished selecting the disk(s) and verified your choices are correct, type **0** in the Choice field, and press **Enter**. The Installation and Settings window displays with the selected disks listed under System Settings.
9. Make any other changes your OS installation requires and proceed with installation.
10. Refer to the AIX Installation Guide for completing the installation.

<http://publib.boulder.ibm.com/infocenter/pseries/v5r3/topic/com.ibm.aix.install/doc/insgdrf/insgdrf.pdf>

---

## Configuring storage subsystems

If you have purchased a Storage Partitioning premium feature, ensure that the premium feature is enabled. For more information, see “Enabling premium features” on page 18.

Complete the following procedures to configure DS4000 Storage Manager for an AIX system. This can be done from the DS4000 SMclient software running on either an AIX or a non-AIX system.

### Adding storage subsystems to SMclient

Complete the following steps to add storage subsystems to DS4000 SMclient:

1. To set up the storage subsystem for AIX and DS4000 SMclient, the subsystem must be physically configured for direct management through the Ethernet connections on each controller. Install SMclient before configuring the subsystem.

**Note:** See “Setting up IP addresses for DS4000 storage controllers” on page 13 for information about assigning IP addresses to the controllers.

2. After the disk subsystem is configured on the network, start SMclient on the host server by typing the following command:

```
# /usr/SMclient/SMclient
```

The Enterprise Management window opens.

3. Complete the following steps to specify the IP addresses of the controllers:

- a. In the Enterprise Management window, click **Edit → Add Storage Subsystem**.
- b. In the Add Storage Subsystem window, type the IP addresses of each controller in the storage subsystem, and click **Add**. The name of the storage subsystem displays in the Enterprise Management window. (If this is the first time the controller has been added to the Enterprise Management window, it will need to be assigned a name.)

**Note:** Failure to add both controllers results in a partially-managed system, where all functions may not be available.

The name of the storage subsystem displays in the Enterprise Management window.

4. Double-click the name of the storage subsystem to open its Subsystem Management window.

## Upgrading controller firmware and NVSRAM

The procedures in this section describe how to download and install DS4000 controller firmware and NVSRAM.

**Note:** If you are upgrading a DS4800, DS4700, or a DS4200 storage subsystem to controller firmware version 07.10.xx.xx, see Appendix D, “Using the IBM System Storage DS4000 Controller Firmware Upgrade Tool,” on page 235.

### Overview

Read the information in the following sections before you begin the download procedures:

- “Using concurrent download”
- “Using traditional or staged download” on page 37

**Using concurrent download:** Depending on your system’s current firmware and AIX device driver levels, you might be able to use *concurrent download*. Concurrent download is a method of downloading firmware to the controllers that does not require you to stop I/O to the controllers during the process.

### Attention:

1. Concurrent download is not supported with controller firmware versions 06.14.xx.xx or 06.15.xx.xx, and might not be supported with other firmware versions. Please see the latest Storage Manager readme file for AIX to find out which firmware versions support concurrent download.
2. You cannot use concurrent firmware download if you change the default setting of the Object Data Manager (ODM) attribute *switch\_retries*. The default is **5**. See “Viewing and setting Object Data Manager (ODM) attributes” on page 60 for more information.
3. If you do not have the correct firmware versions to use concurrent download, you must ensure that all I/O to the controllers is stopped before you upgrade the firmware.

To find out whether you can use concurrent download, see Table 7 on page 39 and the latest Storage Manager readme file for AIX.

4. Upgrading from pre-07.10.xx.xx to 07.10.xx.xx is not concurrent. You must use the upgrade utility and stop all I/O. See Appendix D, “Using the IBM System Storage DS4000 Controller Firmware Upgrade Tool,” on page 235.

**Using traditional or staged download:** There are two methods for downloading the firmware to the controllers:

- “Traditional download”
- “Staged download”

**Traditional download:** The traditional download process takes significantly longer and must be done in one phase, rather than in two phases as with the staged controller firmware download. Therefore the preferred method of controller firmware download is the staged controller firmware download.

**Staged download:** With staged firmware download, the download process occurs in two distinct phases: firmware transfer and firmware activation. You can perform the time-consuming task of loading the firmware online so that it is functionally transparent to the application. You can then defer the activation of the loaded firmware to a convenient time.

Some reasons for activating firmware files at a later time include the following:

- **Time of day**—Activating can take a long time, so you might want to wait until I/O loads are lighter because the controllers will go offline briefly to activate the new firmware.
- **Type of package**—You might want to test the new firmware package on one storage subsystem before activating it on other storage subsystems.
- **Multiple controllers**—You can download controller firmware from the storage management software to all storage subsystem controllers for later activation.

**Notes:**

1. You cannot use staged download to upgrade DS4000 controller firmware version 05.xx.xx.xx to version 06.1x.xx.xx. You can only use staged download if the DS4000 controller firmware version is already 06.1x.xx.xx, and you are downloading another version of 06.1x.xx.xx firmware.
2. Staged controller firmware download is not supported on DS4400 storage subsystems.
3. Staged download is not supported when upgrading to version 07.10.xx.xx. You must use the upgrade utility. See Appendix D, “Using the IBM System Storage DS4000 Controller Firmware Upgrade Tool,” on page 235.

**Important:** Do not perform other storage management tasks, such as creating or deleting logical drives, reconstructing arrays, and so on, while downloading the DS4000 storage subsystem controller firmware. It is recommended that you close all storage management sessions (except for the session that you use to upgrade the firmware) to the DS4000 storage subsystem that you plan to update.

## **Preparing for firmware or NVSRAM download**

To prepare for download, review and complete all of the steps in this section before you start the download procedures.

**Check current versions of controller firmware and NVSRAM:** Versions of controller firmware and NVSRAM that are provided with this product might be later releases than those described in this document.

To check the controller firmware and NVSRAM versions that are currently installed on your system, complete the following steps:

1. In the Subsystem Management window, click **Storage Subsystem → View Profile**. The Storage Subsystem Profile window displays.

2. In the Storage Subsystem Profile window, click the Controllers tab to view the current versions of controller firmware and NVSRAM.
3. Click **Close** to close the Storage Subsystem Profile window.
4. To find whether the versions of controller firmware and NVSRAM that are currently on your storage subsystem are the latest versions, see the Storage Manager readme file for AIX at the following Web site:  
[www-1.ibm.com/servers/storage/support/disk/](http://www-1.ibm.com/servers/storage/support/disk/)  
 Click the link for your storage subsystem. When the storage subsystem page opens, click the **Download** tab.  
 You can also find controller firmware versions listed in Table 2 on page 2.
5. If you find that you do not have the latest versions of the firmware and NVSRAM, download the correct versions from this Web site to a directory on your system, then follow the preparation and upgrade procedures that are described in this section.

**Save the storage subsystem configuration:** Saving the storage subsystem configuration to a script file is necessary in order to restore the configuration in the event of a catastrophic failure.

**Attention:** Do not use this option if the storage subsystem is undergoing an operation that changes any configuration settings. (If any logical drive listed in the Logical View of the Subsystem Management window has a clock icon, then a configuration change is occurring, and you must wait to save the configuration.)

You can also save the storage subsystem profile, by selecting **Storage Subsystem → View Profile** in the Subsystem Management window, and clicking **Save As**. Then, in the Save Profile window, select the sections of the profile that you want to save, specify a name and location for the text file, and click **Save**.

Save the storage subsystem configuration by completing the following steps:

1. In the Subsystem Management window, click **Storage Subsystem → Configuration → Save**. The Save Configuration window displays.
2. In the Save Configuration window, select the elements of the configuration that you want to save, and click **Yes**. A save dialog displays.
3. In the save dialog, specify a name for the script file and select its location.

**Notes<sup>®</sup>:**

- The .cfg extension is used by default for the script file if you do not specify a file extension.
  - Do not store your DS4000 Storage Subsystem configuration script file in the same location as the logical drives that are defined on your DS4000 Storage Subsystem. If you do, and the logical drives fail during the subsequent migration, you will lose data.
4. Click **Save**. The Configuration Saved window displays.
  5. Review the information in the Configuration Saved window, then click **OK** to return to the Subsystem Management window.

**Determine whether you can use concurrent download:** You can use concurrent download only if you are upgrading from one version of controller firmware to a later release of the same version. For example, if you are upgrading from 06.10.xx.xx to 06.12.xx.xx, you can use concurrent download; however, if you are upgrading from



05.xx.xx.xx to 06.1x.xx.xx or 06.xx.xx.xx to 07.10.xx.xx, you *cannot* use concurrent download. You need to stop I/O before upgrading controller firmware.

**Notes:**

1. You cannot use concurrent download to perform an upgrade from controller firmware version 06.xx.xx.xx to version 07.10.xx.xx. You *must* use the IBM System Storage DS4000 Controller Firmware Upgrade Tool to upgrade from version 06.xx.xx.xx to version 07.10.xx.xx. See Appendix D, “Using the IBM System Storage DS4000 Controller Firmware Upgrade Tool,” on page 235. Concurrent download is supported, once the upgrade to version 07.10.xx.xx has successfully completed.
2. Some controller firmware versions might not support concurrent download. See the latest Storage Manager readme file for AIX to find out which firmware versions support concurrent download.
3. Single-controller (SCU) storage subsystem models do not support concurrent download.

Table 7. Firmware versions that support concurrent download (AIX)

DS4000 storage subsystem:	Controller firmware version:
DS4100	06.10.xx.xx, 06.12.xx.xx
DS4200	06.16.88.xx, 06.23.xx.xx, 06.60.xx.xx, 07.10.xx.xx
DS4300 base and Turbo	06.10.xx.xx, 06.12.xx.xx, 06.19.xx.xx, 06.60.xx.xx
DS4400	06.10.xx.xx, 06.12.xx.xx
DS4500	06.10.xx.xx, 06.12.xx.xx, 06.19.xx.xx, 06.60.xx.xx
DS4700	06.16.xx.xx, 06.23.xx.xx, 06.60.xx.xx, 07.10.xx.xx
DS4800	06.16.xx.xx, 06.23.xx.xx, 06.60.xx.xx, 07.10.xx.xx
All other DS4000 storage subsystems	05.30.xx.xx, 06.10.xx.xx, 06.12.xx.xx

**Steps for upgrading the controller firmware**

Complete the following steps to install a new firmware version on the controllers:

1. Download the correct version of the firmware from the Web site that is listed in “Check current versions of controller firmware and NVSRAM” on page 37. Place the file in a designated directory on the host system.
2. Check your system’s current firmware and device driver levels to determine whether you need to stop I/O before upgrading the firmware, using the information that is listed in Table 7 and in the Storage Manager readme file for AIX.
 

**Attention:** If you do not have the correct firmware and device driver levels for concurrent download, you *must* stop I/O to the controllers before you upgrade the firmware.
3. Ensure that the array is in an Optimal state. If it is not, resolve the issue before continuing to the next step.
4. In the Subsystem Management window, click **Advanced** → **Maintenance** → **Download** → **Controller Firmware**. The Download Firmware window displays.
5. Click **Browse** to select the firmware file that you previously downloaded to a directory on the host.
6. If you want to perform a staged firmware download, select the check box next to “Transfer files but don’t activate them (activate later).” If you want to perform a traditional firmware download, do not select the check box, and the firmware will load immediately.

7. Click **Transfer**. The Confirm Download window displays.
8. Click **Yes** to start the download.
9. Verify that the firmware was successfully installed.

### Steps for upgrading the NVSRAM

Complete the following steps to install a new version of NVSRAM on the controllers. NVSRAM will be activated immediately.

1. Download the correct NVSRAM version from the Web site that is listed in “Check current versions of controller firmware and NVSRAM” on page 37. Place the file in a designated directory on the host system.
2. Stop I/O.
3. Ensure that the array is in an Optimal state. If it is not, resolve the issue before continuing to the next step.
4. In the Subsystem Management window, click **Advanced** → **Maintenance** → **Download** → **Controller NVSRAM**. The Download NVSRAM window displays.
5. Click **Browse** to select the NVSRAM file that you previously downloaded to a directory on the host.
6. Click **OK**. The Confirm Download window displays.
7. Click **Yes** to start the download.
8. Verify that the NVSRAM was successfully installed.
9. Start I/O.

---

## Creating storage partitions

To create storage partitions, you must complete the following procedures in this section:

1. “Steps for defining an AIX host group” on page 41
2. “Steps for defining the host and host port” on page 41
3. “Steps for verifying that the host ports match the host” on page 42
4. “Mapping LUNs to a storage partition” on page 43

## Storage partitioning overview

When you begin to create your storage partitions using the procedures in this section, be aware of the following information:

- If your subsystem is running controller firmware 06.12.00.00 or higher, the Storage Manager task assistant provides a Storage Partitioning wizard that you can use to define your host and host ports, and map LUNs to the storage partitions. If your subsystem is running controller firmware 05.xx.xx.xx, you cannot use the wizard. Both types of procedures are documented in this section.
- The procedures in this section assume that you have already created a physical connection between the host and the storage subsystem controllers, and that you have also connected and zoned the SAN switch (if any). If you have not completed these connections, please note that Storage Manager will *not* be able to list the WWPNs of the HBAs during these procedures. In this case you will need to type the WWPNs into the appropriate fields during the steps for defining a host and host ports.
- Create the AIX host group at the storage subsystem level. Do not create host groups at the default group level.

**Exceptions:** If you are running a DS4100 or a DS4300 configuration without partitioning enabled, you can use the default host group.

- In a cluster partition, perform logical drive mappings on the host group level so that all the hosts can see the same storage. In a normal partition, perform logical drive mappings on the host level.

## Steps for defining an AIX host group

A *host group* is an entity in the Storage Partitioning topology that defines a logical collection of host computers that require shared access to one or more logical drives. You can grant individual hosts in a defined host group access to storage partitions, independently of the host group.

Complete the following steps to define a host group:

1. Click the **Mappings View** tab on the Subsystem Management window.
2. In the Topology section of the Mappings window, highlight the name of the storage subsystem, and click **Mappings** → **Define** → **Host Group**.

**Note:** Make sure that the storage subsystem is highlighted in the left panel of the Subsystem Management window. Do not highlight Undefined Mappings.

3. Type the name of the new host group (for example, AIX). Click **Add**, and then click **Close**.

## Steps for defining the host and host port

Complete the steps that are appropriate for your storage subsystem controller firmware type:

- “Controller firmwares 07.10.xx.xx and 06.xx.xx.xx”
- “Controller firmware 05.xx.xx.xx” on page 42

### Controller firmwares 07.10.xx.xx and 06.xx.xx.xx

If your subsystem has controller firmware 07.10.xx.xx installed, complete the following steps to define the host and host ports by using the **Define a host and host ports** wizard:

1. In the Topology section of the Mappings view of the Subsystem Management window, right-click the new host group and select **Define Host**. The Introduction (Define Host) window opens.
2. Click **Next**. The Specify Host Name/HBA Attribute (Define Host) window opens.
3. Type the host name in the Specify Host Name/HBA Attribute (Define Host) window. In the left panel, select the correct WWPN of the HBA host port. Click **Add**.

**Note:** If you there is not yet a physical connection between the host and the DS4000 controllers, as described in the “Storage partitioning overview” on page 40, the WWPNs will not display. In this case, you must type the correct WWPN into the field.

4. You must now provide an alias name for the host port. Click **Edit**, then type an alias name (for example, Port1).
5. On configurations with two or more HBAs, repeat step 1 and step 2 for each host port that you need to define, then proceed to step 4.
6. Click **Next**. The **Specify Host Type** window opens.
7. Select the correct host type, AIX, from the drop down menu and click **Next**. The **Review** window opens.

Failure to change the host type from the default to AIX will cause undesired results.

8. Review the information for accuracy, and make any necessary changes. Then click **Next**.
9. After Storage Manager finishes defining the host and host ports, a dialog window opens. If you need to define another host, select **Define another host**. To finish, click **Exit**. The wizard closes.

### Controller firmware 05.xx.xx.xx

If your subsystem has controller firmware 05.xx.xx.xx installed, complete the following steps to define a host and host ports.

**Note:** IBM recommends upgrading your controllers to the latest controller firmware that is available for your storage subsystem.

1. In the Topology section of the Mappings view of the Subsystem Management window, highlight the new host group and click **Mappings** → **Define** → **Host**.
2. Define the new host. Type the name of the AIX host to which the storage subsystem is attached.
  - a. Click **Add**, and then click **Close**.
  - b. Highlight the host that you just added, then right-click and select **Define Host Port**.
  - c. Type or select the desired host port for the first HBA, and then change the host type to **AIX**. Click **Add**.

**Note:** Failure to change the host type from the default to AIX will cause undesired results.

- d. If you are configuring additional HBAs to this partition, choose the host port for the next HBA and click **Add**, and then click **Close**.

**Recommendation:** Before closing the window, record the name of each host port along with the WWPN of its corresponding HBA, and save the information to a file for future reference.

## Steps for verifying that the host ports match the host

After you set up an AIX host group, complete the following steps to verify that the host ports match the AIX host:

1. Type the following command:

```
lsdev -Cc adapter | grep fcs
```

A list that contains all the HBAs that are in the system is displayed, as shown in the following example:

```
# lsdev -Cc adapter | grep fcs
fcs0    Available 20-58    FC Adapter
fcs1    Available 30-70    FC Adapter
fcs2    Available 40-60    FC Adapter
fcs3    Available 90-58    FC Adapter
fcs4    Available B0-70    FC Adapter
fcs5    Available C0-60    FC Adapter
```

2. Identify the fcs number of the HBA that is connected to the DS4000.
3. Type the following command:

```
lscfg -vl fcs# | grep Network
```

where *fcs#* is the fcs number of the HBA that is connected to the DS4000. The network address number of the HBA is displayed, as in the following example:

```
# lscfg -v | fcs0 | grep Network
Network Address.....10000000C925514C
```

**Note:** A network address is also known as a worldwide port name (WWPN).

4. Verify that the network address number matches the host port number that displays in host partition table of the DS4000 SMclient.
5. Repeat this procedure to verify the second host port.

## Mapping LUNs to a storage partition

This section contains the following procedures:

- “Mapping LUNs to a new partition”
- “Adding LUNs to an existing partition” on page 44

### Mapping LUNs to a new partition

When mapping LUNs for the first time to a newly-created partition, complete the procedure in this section that is appropriate to your storage subsystem controller firmware type.

- “Controller firmwares 07.10.xx.xx and 06.xx.xx.xx”
- “Controller firmware 05.xx.xx.xx” on page 44

**Before you begin:** Read “DS4000 Storage Manager performance planning” on page 14 for information about planning the number of LUNs to map to each partition.

**Controller firmwares 07.10.xx.xx and 06.xx.xx.xx:** When mapping LUNs for the first time to a newly-created partition, complete the following steps to map LUNs to the partition.

**Before you begin:** Read “DS4000 Storage Manager performance planning” on page 14 for information about planning the number of LUNs to map to each partition.

**Important::** If your subsystem is running controller firmware 07.10.xx.xx, you can use the Storage Partitioning wizard feature of the Storage Manager task assistant, instead of this procedure, to map LUNs to a new storage partition.

1. Select the Mappings view of the Subsystem Management window.
2. In the Topology section, right-click the host on which you want to map LUNs, and select **Define Storage Partitioning**. The Define Storage Partitioning window opens.
3. In the Define Storage Partitioning window, select **Host**, then click **Next**.
4. Select the logical drive by name, on the right side of the window.
5. Accept the default LUN ID, or change it, then click **Add**.
6. Repeat step 5 for each LUN that you want to map to the partition.

**Controller firmware 05.xx.xx.xx:** Complete the following steps to map LUNs to a new partition:

1. In the Topology section of the Mappings view of the Subsystem Management window, right-click the host on which you want to map LUNs, and select **Define Storage Partitioning**. The Define Storage Partitioning window opens.
2. In the Define Storage Partitioning window, select **Host**, then click **Next**.
3. Select the logical drive by name, on the right side of the window.
4. Accept the default LUN ID, or change it, then click **Add**.
5. Repeat step 4 for each LUN that you want to map to the partition.

### Adding LUNs to an existing partition

When adding LUNs to an existing partition, complete the following steps to map the new LUNs to the partition.

**Before you begin:** Read “DS4000 Storage Manager performance planning” on page 14 for information about planning the number of LUNs to map to each partition.

1. Select the Mappings view of the Subsystem Management window.
2. In the Topology section, right-click the host on which you want to map LUNs, and select **Define Additional Mappings**. The Define Additional Mapping window opens.
3. In the Define Additional Mapping window, select the following options, and then click **Add**:
  - Host group or host
  - Logical unit number (LUN)(0-255)
  - Logical drive

Repeat these steps for each LUN that you want to add to the partition.

---

## Creating direct and SAN-attached configurations

DS4000 Storage Manager supports IBM DS4000 Fibre Channel Storage Subsystems in direct-attached AIX configurations or in a SAN environment through switches in AIX configurations.

### Creating a direct-attached configuration

**Before you begin:** Ensure that:

- One or two AIX servers can be connected to the DS4000 storage subsystems.
- No external hubs are being used.
- Two-server DS4400 or DS4500 configurations require four host-side minihubs, each with exactly one fibre channel connection from each HBA to a minihub.

**Note:** DS4800, DS4700, DS4300, DS4200 Express, and DS4100 storage subsystems do not have minihubs.

- Single HBA configurations are allowed. If you have a single HBA in a direct-attached configuration, both controllers in the DS4000 must be connected to the HBA through a daisy-chain.

**Attention:** Having a single HBA configuration can lead to loss of access data in the event of a path failure.

**Note:** DS4800, DS4700, DS4300, DS4200, and DS4100 storage subsystems do not support daisy-chain configurations.

Complete the following steps to set up a direct-attached configuration:

1. Connect the HBAs to each controller or minihub port of the DS4000 storage subsystem.
2. Configure and verify the configuration, using the procedures that are described in “Identifying devices on AIX hosts” on page 47 and “Verifying the installation and configuration” on page 50.

## Creating a SAN-attached configuration

**Before you begin:** Ensure that:

- Multiple fibre channel HBAs within the same server must not be able to discover the same DS4000 controller port.
- The IBM Fibre Channel HBAs are isolated from each other if they are connected to the same switch that is connected to the same DS4000 controller port.
- Each fibre channel HBA and controller port must be in its own fabric zone, if they are connecting through a single fibre channel switch, such as 2109-F16.

Multiple DS4000 devices can be configured to the same set of fibre channel HBAs through a fibre channel switch.

**Note:** Single HBA configurations are allowed. If you have a single HBA in a SAN-attached configuration, both controllers in the DS4000 must be fibre channel connected to the HBA through a switch, and both controllers must be within the same SAN zone as the HBA. For more information about zoning and enabling zones, see Appendix F, “Connecting HBAs in a FC switch environment,” on page 245.

**Attention:** Having a single HBA configuration can lead to loss of access data in the event of a path failure.

Complete the following steps to set up a SAN-attached configuration:

1. Connect the HBAs to the switch or switches.
2. Connect the DS4000 storage subsystems to the switch or switches.
3. Set the required zones on the fibre channel switch or switches, if applicable.

**Note:** For more information about zoning and enabling zones, see Appendix F, “Connecting HBAs in a FC switch environment,” on page 245.

4. Configure and verify the configuration.
5. Use the **cfgmgr** command to enable the HBAs to log in to the switch.

---

## Installing the RDAC failover driver

After you install the client software and configure your storage subsystems, use these instructions to install the appropriate DS4000 Storage Manager RDAC device driver.

You must install RDAC on all AIX hosts in your storage subsystem. This section describes how to check the current RDAC driver program driver version level, update the RDAC device driver, and verify that the RDAC update is complete.

## Prerequisites

This section lists the prerequisites for installing the RDAC driver version levels on an AIX system and describes how to verify the current RDAC drive driver version level.

## Installing the RDAC driver

Complete both procedures in this section to install the RDAC driver:

1. “Steps for downloading the AIX file sets”
2. “Steps for installing the RDAC driver” on page 47

### Steps for downloading the AIX file sets

The AIX file sets are not included on the DS4000 Storage Manager installation CD. You can install them from the AIX Operating System CD, if the correct versions are included, or use this procedure to download them from the IBM Fix Central Web site.

Table Table 8 shows file sets that are required for RDAC, for fibre channel host attachment, and for the HBAs that are attached to your system. In addition to the required file sets, optional file sets are also available at the download site.

Please consult your IBM technical support representative if you have any questions about required file sets.

*Table 8. AIX file sets required for RDAC, fibre channel attachment, and HBAs*

<b>RDAC</b>		devices.fcp.disk.array.rte
<b>Fibre channel attachment</b>		devices.pci.df1000f7.com
<b>HBAs</b>	FC 6227	devices.pci.df1000f7.rte
	FC 6228	devices.pci.df1000f9.rte
	FC 6239	devices.pci.df1080f9.rte
	FC 5716	devices.pci.df1000fa.rte
	FC 5758 or FC 5759	devices.pci.df1000fd.rte
<b>AIX</b>	5.2	devices.pci.df1000fd.rte 5.2.0.95
		devices.pci.df1000fa.rte 5.2.0.95
		devices.pci.df1000f9.rte 5.2.0.75
		devices.pci.df1000f7.rte 5.2.0.75
		devices.pci.df1080f9.rte 5.2.0.75
<b>AIX</b>	5.3	devices.pci.df1000f7.rte 5.3.0.30
		devices.pci.df1000fa.rte 5.3.0.50
		devices.pci.df1000fd.rte 5.3.0.50
		devices.pci.df1000f9.rte 5.3.0.30
		devices.pci.df1080f9.rte 5.3.0.30

**Before you begin:** Check the Storage Manager readme file for AIX for the minimum file set versions required for your AIX operating system. See “Readme files and concepts” on page 1 to learn how to find the readme files on the Web.

Complete the following steps to download the latest AIX file set.

1. Open the IBM Fix Central Web site by clicking the following link, or by copying and pasting the link into a browser window:



[www-912.ibm.com/eserver/support/fixes/fcgui.jsp](http://www-912.ibm.com/eserver/support/fixes/fcgui.jsp)

2. In the Product family drop down menu, select **UNIX servers**.
3. In the Product drop down menu, select **AIX operating system**.
4. Select your AIX version.
5. In the Fix type drop down menu, select **Specific fixes**. Click **Continue**.
6. In the Search string field, type or paste the name of the file set (for example, `devices.fcp.disk.array.rte`).
7. Select the latest version in the search results display, and follow the instructions on the Web site to download the file set.
8. Repeat these steps for each file set that you need to download.

**Important:**

1. With AIX 5.3, download the complete maintenance package and update all PTFs together. Do not install each PTF separately.
2. If you have 2102-F10 storage array devices connected to your system, do not install `devices.fcp.disk.array.rte` versions 5.1.0.58 or 5.2.0.17 or later. These versions do not support 2102-F10 devices. Contact your IBM technical support representative for assistance.

### Steps for installing the RDAC driver

Complete the following steps to update the RDAC driver version (`devices.fcp.disk.array.rte`) on an AIX system. Repeat these steps for all AIX systems that are connected to the storage subsystem.

**Before you begin:** Verify whether your AIX systems have the most recent RDAC file sets by checking the Storage Manager readme file for AIX, or by completing step 1 through step 6 of “Steps for downloading the AIX file sets” on page 46. You need to perform this installation only on AIX systems that do not have the most recent RDAC file sets.

1. Download the most recent file sets by completing the procedure described in “Steps for downloading the AIX file sets” on page 46.
2. Verify that the correct version of the software was successfully installed by typing the following command:

```
# ls1pp -ah <file set name>
```

**Example:** `# ls1pp -ah devices.fcp.disk.array.rte`

The verification process returns a table that describes the software installation, including the installation package file set name, version number, action, and action status. If the verification process returns an error, contact your IBM technical support representative. If it does not return an error, then you are finished installing the updated RDAC driver on this AIX system.

3. For each AIX host that is to be attached to a DS4000 storage subsystem, repeat the above steps in order to install and verify the RDAC driver.

After you have finished installing RDAC, you can perform the initial device discovery, which is described in the next section.

---

## Identifying devices on AIX hosts

The RDAC driver creates the following devices that represent the DS4000 storage subsystem configuration, as shown in Figure 5 on page 48:

- dar** The disk array router (dar) device represents the entire array, including the current and the deferred paths to all LUNs (hdisks).
- dac** The disk array controller (dac) devices represent a controller within the storage subsystem. There are two dacs in the storage subsystem.
- hdisk** Each hdisk device represents an individual LUN on the array.
- utm** The universal transport mechanism (utm) device is used only with in-band management configurations, as a communication channel between the SMagent and the DS4000.

**Note:** You might see the utm device listed in command output, whether or not you have an in-band management configuration. For example, a utm might be listed when you run the **lsattr** command on a dac.

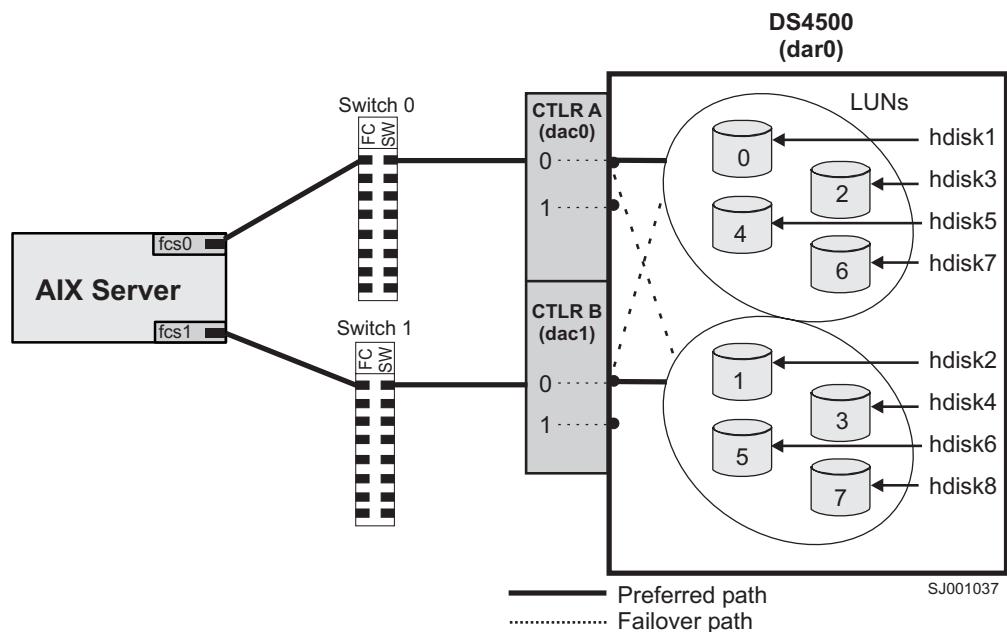

Figure 5. DS4000/AIX system configuration

## Performing initial device discovery

Complete these steps to perform the initial device discovery.

**Before you begin:** Ensure that the DS4000 storage subsystem has been set up, LUNs have been assigned to the host, and the RDAC driver has been installed.

1. Type the following command to probe for the new devices:

```
# cfmgr -v
```

**Note:** In a SAN configuration, the devices do not log into the SAN switch until you run **cfmgr**.

2. Type the following command:

```
# lsdev -Cc disk
```

3. Examine the output of the **lsdev -Cc disk** command to ensure that the RDAC software recognizes the DS4000 logical drives, as shown in the following list:
  - Each DS4200 logical drive is recognized as an “1814 DS4200 Disk Array Device.”
  - Each DS4300 logical drive is recognized as an “1722-600 (600) Disk Array Device.”
  - Each DS4400 logical drive is recognized as an “1742-700 (700) Disk Array Device.”
  - Each DS4500 logical drive is recognized as an “1742-900 (900) Disk Array Device.”
  - Each DS4700 logical drive is recognized as an “1814 DS4700 Disk Array Device.”
  - Each DS4800 logical drive is recognized as an “1815 DS4800 Disk Array Device.”

The following example shows the output of the **lsdev -Cc disk** command for a set of DS4500 LUNs:

```
# lsdev -Cc disk
hdisk0 Available 10-88-00-8,0 16 Bit LVD SCSI Disk Drive
hdisk58 Available 06-08-02 1742-900 (900) Disk Array Device
hdisk59 Available 0A-08-02 1742-900 (900) Disk Array Device
hdisk60 Available 06-08-02 1742-900 (900) Disk Array Device
hdisk62 Available 06-08-02 1742-900 (900) Disk Array Device
```

The following example shows the output of the **lsdev -Cc disk** command for a set of DS4000 LUNs on an AIX 5.3 system:

```
# lsdev -Cc disk
hdisk24 Available 06-08-02 1722-600 (600) Disk Array Device (DS4300)
hdisk25 Available 0A-08-02 1722-600 (600) Disk Array Device (DS4300)
hdisk26 Available 0A-08-02 1814 DS4700 Disk Array Device (DS4700)
hdisk27 Available 0A-08-02 1814 DS4700 Disk Array Device (DS4700)
hdisk77 Available 0A-08-02 1742-900 (900) Disk Array Device (DS4500)
hdisk78 Available 06-08-02 1742-900 (900) Disk Array Device (DS4500)
hdisk79 Available 06-08-02 1815 DS4800 Disk Array Device (DS4800)
hdisk80 Available 0A-08-02 1815 DS4800 Disk Array Device (DS4800)
hdisk142 Available 1V-08-02 1814 DS4200 Disk Array Device
hdisk143 Available 1V-08-02 1814 DS4200 Disk Array Device
```

**Important:** You might discover that the configuration process has created two dacs and two dars on one DS4000 subsystem. This situation can occur when your host is using a partition that does not have any associated LUNs. When that happens, the system cannot associate the two dacs under the correct dar. If there are no LUNs, the system generates two dacs as expected, but it also generates two dars.

The following list shows the most common causes:

- You create a partition and attach the LUNs to it, but you do not add the host ports to the partition. Therefore, the host ports remain in the default partition.
- You replace one or more HBAs, but do not update the worldwide name (WWN) of the partition for the HBA.
- You switch the DS4000 from one set of HBAs to another as part of a reconfiguration, and do not update the WWNs.

In each of these cases, resolve the problem, and run **cfgmgr** again. The system removes the extra dar, or moves it from the Available state to the Defined state. (If the system moves the dar into the Defined state, you can then delete it.)

**Note:** When you perform the initial device identification, the Object Data Manager (ODM) attributes of each device are updated with default values. In most cases and for most configurations, the default values are satisfactory. However, there are some values that can be modified for maximum performance and availability. See “Viewing and setting Object Data Manager (ODM) attributes” on page 60.

See “Using the **lsattr** command to view ODM attributes” on page 67 for information about using the **lsattr** command to view attribute settings on an AIX system.

---

## Verifying the installation and configuration

After you have performed the initial device identification, complete the following procedures to verify that all of your DS4000 device names and paths are correct and that AIX recognizes your dars, dacs, and hdisks.

- “Identifying the controller ID numbers”
- “Identifying device names and bus numbers” on page 51
- “Identifying logical drives by operating system device names” on page 57
- “Identifying FlashCopy logical drive types” on page 59

**Tip:** Verify your installation and configuration before you mount your file systems and install your applications.

## Identifying the controller ID numbers

Choose one of the following options to identify the controller ID number of a dac:

- “Using the **lsattr -El** command”
- “Using the SMclient Controller Properties window” on page 51

### Using the **lsattr -El** command

1. Type the **lsattr -El** command, as follows:

```
# lsattr -El dacname
```

where *dacname* is the name of the dac whose controller ID number you want to identify.

2. Find the value of the `controller_SN` attribute, as shown in the following example. This value is the controller ID number of `dac1`.

```
# lsattr -El dac1
GLM_type          low                GLM type          False
alt_held_reset    no                Alternate held in reset False
cache_size        1024             Cache Size in MBytes False
controller_SN    1T14148774       Controller serial number False
ctrl_type         1742-0900        Controller Type    False
location          location          Location Label     True
lun_id            0x0              Logical Unit Number False
node_name         0x200400a0b80f434d FC Node Name      False
passive_control   no                Passive controller False
scsi_id           0x11a00          SCSI ID            False
utm_lun_id        none             Logical Unit Number False
ww_name           0x200500a0b80f434e World Wide Name   False
```

## Using the SMclient Controller Properties window

1. In the Logical/Physical view of the Subsystem Management window, right-click a controller and select **Properties**. The Controller Properties window opens.
2. In the Controller Properties window, find the value of the Serial number attribute. In the example shown in Figure 6, the controller in slot A has the controller ID number (serial number) 1T14148774, and is represented by dac1.

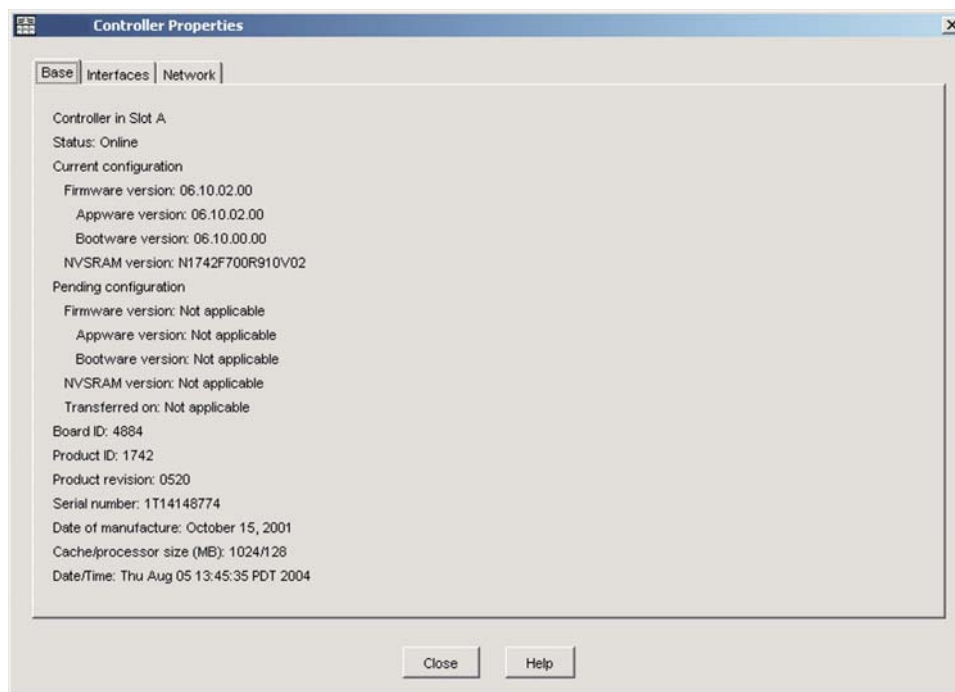

Figure 6. Controller Properties window

## Identifying device names and bus numbers

As mentioned previously in this chapter, the RDAC software uses *dars* to represent the disk array routers, *dacs* to represent the disk array controllers, and *hdisks* to represent the logical drives.

After these operating system device names are found, you can use one or more of the following methods in AIX to get information about device names, bus numbers, and other attributes. You can then use this information to correlate the device names with their logical drives and preferred and alternate paths:

### “Using the lsdev command”

The **lsdev** command displays devices and their characteristics. **lsdev** also shows the state of the devices at startup time, or the last time that the **cfgmgr -v** command was run.

### “Using the fget\_config command” on page 53

The **fget\_config** command displays controllers and hdisks that are associated with a specified DS4000 (dar). **fget\_config** also shows the current state and logical drive (hdisk) ownership.

### “Using the lsattr command” on page 56

The **lsattr** command displays device attributes and possible values. Attributes are only updated at startup time, or the last time that the **cfgmgr -v** command was run.

## Using the lsdev command

The examples in this section show you how to use the **lsdev** command to show the status of dars, dacs and hdisks.

**lsdev command, example 1:** Figure 7 shows the use of the **lsdev** command combined with the **grep** command to view the status of the dar, which represents a DS4000 storage subsystem.

In the example, dar0 is a machine type 1742, which is a DS4400. It is in the Available state, which is the state at the time when the device was last configured by AIX.

```
# lsdev -C |grep dar0
dar0      Available          1742      (700) Disk Array Router
```

Figure 7. **lsdev** command, example 1

**lsdev example 2:** Figure 8 shows the use of the **lsdev** command combined with the **grep** command to view the status of two dacs, which represent the DS4000 storage subsystem controllers.

In the example, as in the previous example, a DS4400 is shown in an Available state. Each dac has its own location code, or *path*, which are represented by the values 11-08-01 and 14-08-01. Each AIX system has its own set of location codes that describe the internal path of that device, including bus and host-adaptor locations.

See the service manual for your system type to identify device locations.

```
# lsdev -C |grep dac
dac0      Available 11-08-01    1742      (700) Disk Array Controller
dac1      Available 14-08-01    1742      (700) Disk Array Controller
```

Figure 8. **lsdev** command, example 2

**lsdev example 3:** Figure 9 on page 53 shows the use of the **lsdev** command combined with the **grep** command to view the status and location codes of eight DS4400 hdisks.

In the example, note that the location codes of the odd-numbered hdisks correspond to the location code of dac0 that is listed in the previous example, and that the location codes of the even-numbered hdisks correspond to the location code of dac1. This means that the preferred I/O path for hdisks 1, 3, 5, and 7 is through dac0, and the failover path is through dac1. Conversely, the preferred path for hdisks 2, 4, 6, and 8 is through dac1, and failover path is through dac0.

```
# lsdev -Cc |grep hdisk
hdisk0    Available 40-60-00-4,0 16 Bit LVD SCSI Disk Drive
hdisk1    Available 11-08-01      1742      (700) Disk Array Device
hdisk2    Available 14-08-01      1742      (700) Disk Array Device
hdisk3    Available 11-08-01      1742      (700) Disk Array Device
hdisk4    Available 14-08-01      1742      (700) Disk Array Device
hdisk5    Available 11-08-01      1742      (700) Disk Array Device
hdisk6    Available 14-08-01      1742      (700) Disk Array Device
hdisk7    Available 11-08-01      1742      (700) Disk Array Device
hdisk8    Available 14-08-01      1742      (700) Disk Array Device
```

Figure 9. **lsdev** command, example 3

**lsdev example 4:** Figure 10 shows the use of the **lsdev** command combined with the **grep** command to search for the first two numbers of the location code. The resulting display shows all the devices that are on the preferred fabric path from the HBA to the hdisk.

Figure 10. **lsdev** command, example 4

```
# lsdev -C|grep 11-08
fcs0      Available 11-08          FC Adapter
fscsi0    Available 11-08-01      FC SCSI I/O Controller Protocol Device
dac0      Available 11-08-01      1742      (700) Disk Array Controller
hdisk1    Available 11-08-01      1742      (700) Disk Array Device
hdisk3    Available 11-08-01      1742      (700) Disk Array Device
hdisk5    Available 11-08-01      1742      (700) Disk Array Device
hdisk7    Available 11-08-01      1742      (700) Disk Array Device
hdisk8    Available 11-08-01      1742      (700) Disk Array Device
```

## Using the **fget\_config** command

You can use the **fget\_config** command to display current configuration information for a DS4000 subsystem.

Use the following command syntax for the **fget\_config** command:

```
fget_config -A | -l | -v dar_name
```

- **A**     Displays output for all the configured dars in the subsystem. If you use this parameter, do not specify a dar name.
- **l**     Displays output only for the dar that you specify.
- **v**     Displays more information about the dar or dars, such as the user array names that were created when you configured the DS4000 subsystem.

**fget\_config example 1:** Figure 11 on page 54 shows a sample output from the **fget\_config -l dar3** command. A dac can be Active, Passive, or Offline. Only dacs that are in Active state are used for I/O. In the output, you can see that dar3

consists of dac6 and dac9.

```
# fget_config -l dar3

dac6 ACTIVE dac9 ACTIVE
hdisk26 dac9
hdisk27 dac6
hdisk28 dac9
hdisk29 dac6
hdisk30 dac9
hdisk31 dac6
hdisk32 dac9
hdisk33 dac9
hdisk83 dac6
```

Figure 11. **fget\_config** command, example 1

**fget\_config example 2:** Figure 12 shows a sample output from the **fget\_config -vl dar3** command. Note that using the **-v** parameter causes the user array name and the LUN names to be displayed:

```
# fget_config -vl dar3

User array name = 'D59 DS4500 #1'
dac6 ACTIVE dac9 ACTIVE

Disk    DAC    LUN Logical Drive
utm          10
hdisk26 dac9    1 multipart11
hdisk27 dac6    2 multipart12
hdisk28 dac9    3 multipart13
hdisk29 dac6    4 multipart14
hdisk30 dac9    5 multipart15
hdisk31 dac6    6 multipart16
hdisk32 dac9    7 multipart17
hdisk33 dac9    9 multipart19
hdisk83 dac6    8 multipart18
```

Figure 12. **fget\_config** command, example 2

**fget\_config example 3:** Figure 13 on page 55 shows a sample output from the **fget\_config -A** command. Note that using the **-A** parameter causes all the dars to be displayed:



```

# fget_config -A

---dar0---
dac3 ACTIVE dac0 ACTIVE
hdisk4 dac3
hdisk5 dac0
hdisk6 dac3
hdisk7 dac0
hdisk8 dac3
hdisk10 dac0
hdisk11 dac3
hdisk12 dac0
hdisk13 dac3
hdisk14 dac0

---dar1---
dac1 ACTIVE dac4 ACTIVE
hdisk15 dac1
hdisk16 dac1
hdisk17 dac4
hdisk18 dac1
hdisk19 dac4
hdisk20 dac1
hdisk21 dac4
hdisk22 dac1
hdisk23 dac4
hdisk24 dac1

---dar2---
dac2 ACTIVE dac5 ACTIVE
hdisk25 dac5

---dar3---
dac6 ACTIVE dac9 ACTIVE
hdisk26 dac9
hdisk27 dac6
hdisk28 dac9
hdisk29 dac6
hdisk30 dac9
hdisk31 dac6
hdisk32 dac9
hdisk33 dac9
hdisk83 dac6

```

Figure 13. **fget\_config** command, example 3

**fget\_config example 4:** Figure 14 on page 56 shows a sample output from the **fget\_config -Av** command. Note that using the **-v** parameter causes the user array names and the LUN names to display:

```

# fget_config -Av

---dar0---
User array name = 'D59S Flute-2
(DS4500) #1'
dac3 ACTIVE dac0 PASSIVE

Disk    DAC    LUN Logical Drive
hdisk4  dac3    0  dualpart0
hdisk5  dac3    1  dualpart1
hdisk6  dac3    2  dualpart2
hdisk7  dac3    4  dualpart4
hdisk8  dac3    5  dualpart5
hdisk10 dac3    8  dualpart8
hdisk11 dac3    9  dualpart9
hdisk12 dac3   10  dualpart10
hdisk13 dac3   11  dualpart11
hdisk14 dac3   12  dualpart12

---dar1---
User array name = 'D59 DS4500 #1'
dac1 ACTIVE dac4 ACTIVE

Disk    DAC    LUN Logical Drive
utm     DAC    LUN Logical Drive
utm     10
hdisk15 dac1    0  multipart20
hdisk16 dac1    1  multipart1
hdisk17 dac4    2  multipart2
hdisk18 dac1    3  multipart3
hdisk19 dac4    4  multipart4
hdisk20 dac1    5  multipart5
hdisk21 dac4    6  multipart6
hdisk22 dac1    7  multipart7
hdisk23 dac4    8  multipart8
hdisk24 dac1    9  multipart9

---dar2---
User array name = 'D59S DS4500 #2'
dac2 ACTIVE dac5 ACTIVE

Disk    DAC    LUN Logical Drive
utm     DAC    LUN Logical Drive
utm     31
hdisk25 dac5    0  1

---dar3---
User array name = 'D59 DS4500 #1'
dac6 ACTIVE dac9 ACTIVE

Disk    DAC    LUN Logical Drive
utm     DAC    LUN Logical Drive
utm     10
hdisk26 dac9    1  multipart11
hdisk27 dac6    2  multipart12
hdisk28 dac9    3  multipart13
hdisk29 dac6    4  multipart14
hdisk30 dac9    5  multipart15
hdisk31 dac6    6  multipart16
hdisk32 dac9    7  multipart17
hdisk33 dac9    9  multipart19
hdisk83 dac6    8  multipart18

```

Figure 14. `fget_config` command, example 4

### Using the `lsattr` command

You can also use the `lsattr` command to find out which controller owns a particular hdisk.

Figure 15 on page 57 shows portions of the outputs from several `lsattr` commands.

In the example, `hdisk1` belongs to the controller represented by `dac0`. The hdisk has the same SCSI ID as the controller (`dac`) that owns it.

```

# lsattr -El dac0
GLM_type          low                GLM type          False
alt_held_reset    no                 Alternate held in reset False
cache_size        1024              Cache Size in MBytes False
controller_SN     1T23559428        Controller serial number False
ctrl_type         1742-0900         Controller Type    False
location          Location Label     True
lun_id            0x0               Logical Unit Number False
node_name         0x200400a0b80f434d FC Node Name      False
passive_control   no                 Passive controller False
scsi_id           0x11100           SCSI ID           False
utm_lun_id        none              Logical Unit Number False
ww_name           0x200400a0b80f434e World Wide Name  False

# lsattr -El dac1
GLM_type          low                GLM type          False
alt_held_reset    no                 Alternate held in reset False
cache_size        1024              Cache Size in MBytes False
controller_SN     1T23559493        Controller serial number False
ctrl_type         1742-0900         Controller Type    False
location          Location Label     True
lun_id            0x0               Logical Unit Number False
node_name         0x200400a0b80f434d FC Node Name      False
passive_control   no                 Passive controller False
scsi_id           0x11a00           SCSI ID           False
utm_lun_id        none              Logical Unit Number False
ww_name           0x200500a0b80f434e World Wide Name  False

# lsattr -El hdisk1
----- Parts removed:
scsi_id           0x11100           SCSI ID           False
size              4096              Size in Mbytes    False
write_cache       yes               Write Caching enabled False

```

Figure 15. **lsattr** command example

## Identifying logical drives by operating system device names

The **lsattr** command provides detailed information about a logical drive, including information that allows you to map the system device name to the logical drive on the DS4000 storage subsystem.

The following example shows the output of an **lsattr** command for a LUN named **hdisk4**:

```

# lsattr -El hdisk4
pvid          none                Physical volume identifier      False
q_type        simple              Queuing Type                    False
queue_depth   30                            Queue Depth                     True
reserve_lock  yes                            RESERVE device on open         True
write_cache   yes                            Write Caching enabled          True
size          6062                          Size in Mbytes                  False
raid_level    0                            RAID Level                      False
rw_timeout    30                            Read/Write Timeout value       True
reassign_to   120                          Reassign Timeout value         True
scsi_id       0x11000                        SCSI ID                          False
lun_id        0x0002000000000000          Logical Unit Number             False
cache_method  fast_write                     Write Caching method           True
prefetch_mult 0                            Multiple of blocks to prefetch on read True
ieee_volname  600A0B80000F14AF000003D140C046A2 IEEE Unique volume name        False

```

In the example, you can see that hdisk4 is a 6 GB LUN of type RAID 0, with a LUN ID of 2, and an IEEE volume name of 600A0B80000F14AF000003D140C046A2.

You can make a more exact correlation using the distinctive *ieee\_volname* attribute. The value of this attribute on the AIX host is the same as the value of the *Logical Drive ID* on the DS4000 subsystem. You can see the *Logical Drive ID* in the Change Mapping window of DS4000 Storage Manager, which is shown in Figure 16 on page 59.

To view the Change Mapping window, click the **Mappings view** tab in the Subsystem Management window. Right-click the name of the logical drive whose attributes you want to see, and select **Change Mapping**.

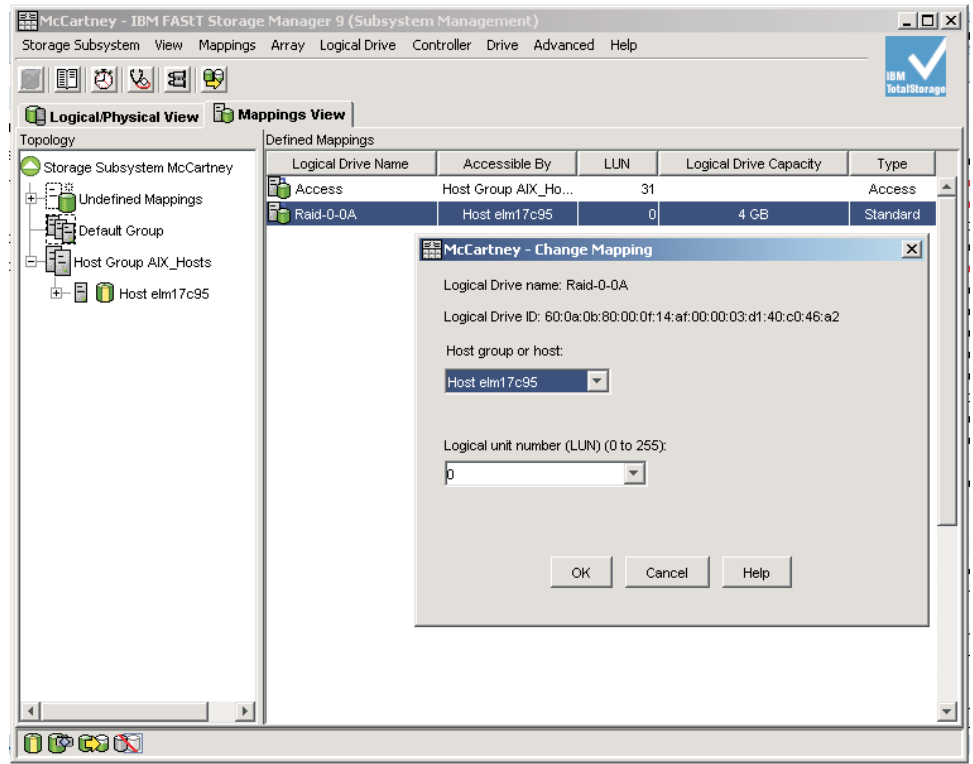

Figure 16. Change Mappings window

You can also identify the system disk name by viewing the *Subsystem ID (SSID)* attribute in the Logical Drive Properties window of DS4000 Storage Manager. The value of the *Subsystem ID (SSID)* attribute on the DS4000 subsystem is the same as the value of the *lun\_id* attribute on the AIX host.

To open the Logical Drive Properties window, right-click the name of the logical drive in the Logical/Physical view of the Subsystem Management window and select **Properties**.

## Identifying FlashCopy logical drive types

Complete the following steps to identify FlashCopy logical drive types:

1. Run the following command to list available logical drives:

```
# lsdev -Cc disk
```

A list of available logical drives displays, as shown in the following example:

```
[root@hostname] / # lsdev -Cc disk |pg
hdisk0 Available 40-60-00-4,0 16 Bit LVD SCSI Disk Drive
hdisk1 Available 40-60-00-8,0 16 Bit LVD SCSI Disk Drive
hdisk2 Available 11-08-01 1742-900 (900) Disk Array Device
hdisk3 Available 11-08-01 1742-900 (900) Disk Array Device
hdisk4 Available 11-08-01 1742-900 (900) Disk Array Snapshot
```

The FlashCopy array is identified by the term Disk Array Snapshot.

2. Run the following command to display the state of each controller in a DS4000 array:

```
# fget_config -Av
```

A list displays, as shown in the following example:

```
[root@hostname] / # fget_config -Av
---dar0---
User array name = 'DS4000 System 1'
dac0 ACTIVE dac1 ACTIVE
dac0-hdisk2      Raid-0-0B
dac1-hdisk3      Raid-0-1B
dac1-hdisk4      Raid-3-0A-1  Snapshot Volume
```

The FlashCopy logical drive is identified by the term Snapshot Volume.

For more information about the **lsdev** and **fget\_config** commands, see “Identifying device names and bus numbers” on page 51.

---

## Viewing and setting Object Data Manager (ODM) attributes

Some of the ODM attributes are for information purposes only. These information-only attributes show how the DS4000 storage subsystem is configured, or its current state. You can modify other attributes using SMIT or by using the AIX **chdev -p** command.

### Attribute definitions

The following tables list definitions and values of the ODM attributes for dars, dacs and hdisks:

- Table 9: *Attributes for dar devices*
- Table 10 on page 62: *Attributes for dac devices*
- Table 11 on page 63: *Attributes for hdisk devices*

#### Notes:

1. Attributes with True in the Changeable column can be modified from their default settings.
2. Attributes with False in the Changeable column are for informational or state purposes only. However, some attributes with False in the Changeable column can be modified using DS4000 Storage Manager.
3. The **lsattr -EI** (uppercase E, lowercase L) command is another way to determine which attributes can be modified. Attributes that can be modified display True in the last column of the **lsattr -EI** output. You can also display the default values by using the **lsattr -DI** command. See “Using the lsattr command to view ODM attributes” on page 67 for more information.

Table 9. *Attributes for dar devices*

Attribute	Definition	Changeable (T/F)	Possible value
<i>act_controller</i>	List of controllers in the active state at the time of configuration.	False	Set at configuration time by the RDAC software.
<i>all_controller</i>	List of controllers that comprise this array; usually there are two dac devices.	False	Set at configuration time by the RDAC software.

Table 9. Attributes for dar devices (continued)

Attribute	Definition	Changeable (T/F)	Possible value
<i>held_in_reset</i>	Name of the controller that was in the held-in-reset state at the time of configuration, or <b>none</b> if no controllers were in that state.	True	Set at configuration time by the RDAC software. Should not be changed.
<i>load_balancing</i>	Indicator that shows whether load balancing is enabled ( <b>yes</b> ) or disabled ( <b>no</b> ); see the definition of the <i>balance_freq</i> attribute for more information.	True	Yes or No. <b>Attention:</b> You should only set the <i>load_balancing</i> attribute to <b>yes</b> in single-host configurations.
<i>autorecovery</i>	Indicator that shows whether the device returns the array to dual-active mode when it detects proper operation of both paths and controllers ( <b>yes</b> ) or not ( <b>no</b> ).	True	Yes or No. See restrictions on use.
<i>hlthchk_freq</i>	Number that specifies how often health checks are performed, in seconds.	True	1 - 9999. Should not be changed
<i>aen_freq</i>	Number that specifies how often polled AEN checks are performed, in seconds.	True	1 - 9999. Should not be changed
<i>balance_freq</i>	If <i>load_balancing</i> is enabled, number that specifies how often the system performs load-balancing on the array, in seconds.	True	1 - 9999 - should not be changed
<i>fast_write_ok</i>	Indicator that shows whether fast-write write-caching is available for this system ( <b>yes</b> ) or not ( <b>no</b> ).	False	Yes or No. State of DS4000 configuration.
<i>cache_size</i>	Cache size for both controllers, in megabytes; <b>0</b> if the sizes do not match.	False	512 or 1024. Set by DS4000.

Table 9. Attributes for dar devices (continued)

Attribute	Definition	Changeable (T/F)	Possible value
<i>switch_retries</i>	Number that specifies how many times to retry failed switches, in integers.	True	0 - 255. Default: 5  For most configurations, the default is the best setting. If you are using HACMP™, it can be helpful to set the value to <b>0</b> . <b>Attention:</b> You cannot use concurrent firmware download if you change the default setting.

Table 10. Attributes for dac devices

Attribute	Definition	Changeable (T/F)	Possible value
<i>passive_control</i>	Indicator that shows whether this controller was in passive state at the time of configuration ( <b>yes</b> ) or not ( <b>no</b> ).	False	Yes or No. State of DS4000 configuration.
<i>alt_held_reset</i>	Indicator that shows whether the alternate controller was in the held-in-reset state at the time of configuration ( <b>yes</b> ) or not ( <b>no</b> ).	False	Yes or No. State of DS4000 configuration.
<i>controller_SN</i>	Serial number of this controller.	False	Set by DS4000.
<i>ctrl_type</i>	Type of array this controller belongs to. A value of value of <b>1722</b> indicates DS4300; a value of <b>1742</b> indicates DS4400; a value of <b>1742-900</b> indicates DS4500.	False	1742, 1722, 1742-900. Set by DS4000.
<i>cache_size</i>	Cache size of this controller, in megabytes.	False	512, 1024. Set by DS4000.
<i>scsi_id</i>	SCSI identifier of this controller.	False	Set by SAN, reported by AIX.
<i>lun_id</i>	Logical unit number of this controller.	False	Set by DS4000.



Table 10. Attributes for dac devices (continued)

Attribute	Definition	Changeable (T/F)	Possible value
<i>utm_lun_id</i>	Logical unit number of this controller, or <b>none</b> if UTM (access logical drives) is not enabled.	False	0 - 31. Set by DS4000 Storage Manager.
<i>node_name</i>	Name of the fibre channel node.	False	Set by DS4000
<i>location</i>	User-defined location label for this controller; the system does not use this value.	True	Set by DS4000 Storage Manager.
<i>ww_name</i>	Fibre channel worldwide name of this controller.	False	Set by DS4000.
<i>GLM_type</i>	GLM type used for this controller.	False	High or Low. Set by DS4000.

Table 11. Attributes for hdisk devices

Attribute	Definition	Changeable (T/F)	Possible value
<i>pvid</i>	AIX physical volume identifier, or <b>none</b> if not set.	False	Set by AIX.
<i>q_type</i>	Queueing type for this device; must be set to <b>simple</b> .	False	Set by AIX. Must be "simple".
<i>queue_depth</i>	Number that specifies the depth of the queue based on system configuration; reduce this number if the array is returning a BUSY status on a consistent basis.	True	1 - 64 <b>Note:</b> See "Setting the queue depth for hdisk devices" on page 65 for important information about setting this attribute.
<i>PR_key_value</i>	Required only if the device supports any of the persistent reserve policies. This attribute is used to distinguish between different hosts.	True	1-64, or None. <b>Note:</b> You must set this attribute to non-zero before the <i>reserve_policy</i> attribute is set.
<i>reserve_policy</i>	Persistent reserve policy, which defines whether a reservation methodology is employed when the device is opened.	True	<i>no_reserve</i> <i>PR_shared</i> , <i>PR_exclusive</i> , or <i>single_path</i>

Table 11. Attributes for hdisk devices (continued)

Attribute	Definition	Changeable (T/F)	Possible value
<i>max_transfer</i>	Maximum transfer size is the largest transfer size that can be used in sending I/O.	True	Numeric value; Default = 1 MB <b>Note:</b> Usually unnecessary to change default, unless very large I/Os require increasing the value.
<i>write_cache</i>	Indicator that shows whether write-caching is enabled on this device ( <b>yes</b> ) or not ( <b>no</b> ); see the definition of the <i>cache_method</i> attribute for more information.	False	Yes or No.
<i>size</i>	Size of this logical drive.	False	Set by DS4000.
<i>raid_level</i>	Number that specifies the RAID level of this device.	False	0, 1, 3, 5. Set by DS4000 Storage Manager.
<i>rw_timeout</i>	Number that specifies the read/write timeout value for each read/write command to this array, in seconds; usually set to 30.	True	30 - 180. Should not be changed from default.
<i>reassign_to</i>	Number that specifies the timeout value for FC reassign operations, in seconds; usually set to 120.	True	0 - 1000. Should not be changed from default.
<i>scsi_id</i>	SCSI identifier at the time of configuration.	False	Set by SAN, reported by AIX.
<i>lun_id</i>	Logical unit number of this device.	False	0 - 255. Set by DS4000 Storage Manager.

Table 11. Attributes for hdisk devices (continued)

Attribute	Definition	Changeable (T/F)	Possible value
<i>cache_method</i>	<p>If <i>write_cache</i> is enabled, the write-caching method of this array; set to one of the following:</p> <ul style="list-style-type: none"> <li>• <b>default.</b> Default mode; the word "default" is not seen if <i>write_cache</i> is set to yes.</li> <li>• <b>fast_write.</b> Fast-write (battery-backed, mirrored write-cache) mode.</li> <li>• <b>fw_unavail.</b> Fast-write mode was specified but could not be enabled; write-caching is not in use.</li> <li>• <b>fast_load.</b> Fast-load (non-battery-backed, non-mirrored write-cache) mode.</li> <li>• <b>fl_unavail.</b> Fast-load mode was specified but could not be enabled.</li> </ul>	False	Default, fast_write, fast_load, fw_unavail, fl_unavail.
<i>prefetch_mult</i>	Number of blocks to be prefetched into read cache for each block read.	False	0 - 100.
<i>ieee_volname</i>	IEEE unique logical drive name identifier for this logical drive.	False	Set by DS4000.

## Setting the queue depth for hdisk devices

Setting the *queue\_depth* attribute to the appropriate value is important for system performance. If you have a large DS4000 configuration with many logical drives and hosts attached, use this setting for high performance.

This section provides methods for calculating your system's maximum queue depth, which you can use as a guideline to help you determine the best queue depth setting for your configuration.

**Calculating maximum queue depth:** The formula for calculating the maximum queue depth for your system depends on which firmware version is installed on the controller. Use one of the following formulas to calculate the maximum queue depth for your system.

**Important:**

1. The maximum queue depth might not be an optimal setting in all cases. Use the maximum queue depth as a guideline, and adjust the setting as necessary for your specific configuration.
2. In systems with one or more SATA devices attached, you might need to set the queue depth attribute to a lower value than the maximum queue depth.

**• Formula for controller firmware versions 06.1x.xx.xx or 05.4x.xx.xx**

On DS4000 storage systems that are running DS4000 controller firmware versions 05.4x.xx.xx, 06.1x.xx.xx, or later, use the following formula to determine the maximum queue depth:

$$2048 / (\text{number-of-hosts} * \text{LUNs-per-host} )$$

For example, a system with four hosts, each with 32 LUNs, would have a maximum queue depth of **16**:

$$2048 / ( 4 * 32 ) = 16$$

**• Formulas for controller firmware version 07.10.xx.xx**

On DS4800 and DS4700/DS4200 storage systems that are running DS4000 controller firmware version 07.10.xx.xx, use the following formulas to determine the maximum queue depth:

**DS4800:** 
$$4096 / (\text{number-of-hosts} * \text{LUNs-per-host} )$$

For example, a DS4800 system with four hosts, each with 32 LUNs, would have a maximum queue depth of **32**:

$$4096 / ( 4 * 32 ) = 32$$

**DS4700/DS4200:** 
$$2048 / (\text{number-of-hosts} * \text{LUNs-per-host} )$$

For example, a DS4700 system or a DS4200 system with four hosts, either with 32 LUNs, would have a maximum queue depth of **16**:

$$2048 / ( 4 * 32 ) = 16$$

**• Formula for controller firmware versions 06.1x.xx.xx or 05.4x.xx.xx**

On DS4000 storage systems that are running DS4000 controller firmware versions 05.4x.xx.xx, 06.1x.xx.xx, or later, use the following formula to determine the maximum queue depth:

$$2048 / (\text{number-of-hosts} * \text{LUNs-per-host} )$$

For example, a system with four hosts, each with 32 LUNs, would have a maximum queue depth of **16**:

$$2048 / ( 4 * 32 ) = 16$$

**• Formula for controller firmware version 05.30.xx.xx**

On DS4000 storage systems that are running DS4000 controller firmware version 05.30.xx.xx or earlier, use the following formula to determine the maximum queue depth:

$$512 / (\text{number-of-hosts} * \text{LUNs-per-host} )$$

For example, a system with four hosts, each with 32 LUNs, would have a maximum queue depth of **4**:

$$512 / ( 4 * 32 ) = 4$$

**Setting queue depth attribute:** You can set the `queue_depth` attribute using the `chdev -l` command, as shown in the following example:

```
# chdev -l hdiskX -a queue_depth=y -P
```

where **X** is the name of the hdisk and **y** is the queue depth setting.

**Note:** Use the `-P` flag to make the changes permanent in the Customized Devices object class.

## Using the `lsattr` command to view ODM attributes

To view the Object Data Manager (ODM) attribute settings for `dars`, `dacs`, and `hdisks`, use the `lsattr` command, as follows:

- To view the default settings, type `lsattr -DI`.
- To view the attributes that are currently set on the system, type `lsattr -EI`.

The `lsattr -EI` output examples shown in Figure 17, Figure 18, and Figure 19 on page 68 display the ODM attribute settings for a `dar`, a `dac` and an `hdisk`.

```
# lsattr -EI dar0
act_controller dac0,dac1 Active Controllers           False
aen_freq      600      Polled AEN frequency in seconds           True
all_controller dac0,dac1 Available Controllers           False
autorecovery  no          Autorecover after failure is corrected       True
balance_freq  600      Dynamic Load Balancing frequency in seconds  True
cache_size    128      Cache size for both controllers             False
fast_write_ok yes       Fast Write available                         False
held_in_reset none     Held-in-reset controller                     True
hlthchk_freq  600      Health check frequency in seconds           True
load_balancing no       Dynamic Load Balancing                       True
switch_retries 5       Number of times to retry failed switches     True
```

Figure 17. **Example 1:** Displaying the attribute settings for a `dar`

```
# lsattr -EI dac0
GLM_type      low       GLM type                                       False
alt_held_reset no       Alternate held in reset                       False
cache_size    128      Cache Size in MBytes                          False
controller_SN 1T24594458 Controller serial number                     False
ctrl_type     1722-600 Controller Type                              False
location      location  Location Label                               True
lun_id        0x0      Logical Unit Number                          False
node_name     0x200200a0b80f14af FC Node Name                                False
passive_control no       Passive controller                           False
scsi_id       0x11000  SCSI ID                                       False
utm_lun_id    0x001f000000000000 Logical Unit Number                          False
ww_name       0x200200a0b80f14b0 World Wide Name                              False
```

Figure 18. **Example 2:** Displaying the attribute settings for a `dac`

cache_method	fast_write	Write Caching method	False
ieee_volname	600A0B8...1063F7076A7	IEEE Unique volume name	False
lun_id	0x0069...000000	Logical Unit Number	False
prefetch_mult	12	Multiple of blocks to prefetch on read	False
pvid	none	Physical volume identifier	False
q_type	simple	Queuing Type	False
queue_depth	2	Queue Depth	True
raid_level	5	RAID Level	False
reassign_to	120	Reassign Timeout value	True
reserve_lock	yes	RESERVE device on open	True
rw_timeout	30	Read/Write Timeout value	True
scsi_id	0x11f00	SCSI ID	False
size	2048	Size in Mbytes	False
write_cache	yes	Write Caching enabled	False

Figure 19. **Example 3:** Displaying the attribute settings for an hdisk

**Note:** In Figure 19, the **ieee\_volname** and **lun\_id** attribute values are shown abbreviated. An actual output would show the values in their entirety.

---

## Additional AIX configuration information

This section contains the following procedures:

- “Disabling DS4000 cache mirroring”
- “Using fast I/O failure for fibre channel devices” on page 69
- “Using dynamic tracking of fibre channel devices” on page 70
- “Using dynamic capacity expansion and dynamic volume expansion” on page 70

### Disabling DS4000 cache mirroring

Cache mirroring is enabled on the DS4000 storage subsystem by default. However, you might want to disable this function in certain environments where high performance is a critical factor (such as streaming media applications).

For most applications, cache mirroring should remain enabled.

**Attention:** You must be careful when you disable cache mirroring, particularly when the write cache function is enabled.

- If a controller failure or a power down occurs, data that is in the write cache (but not written to the physical disk media) might be lost. This can result in corrupted files, file systems, or databases.
- On AIX 5.2, and 5.3, cache mirroring is *not* automatically re-enabled the next time the system is restarted or when you run the **cfgmgr** command.

#### Steps for disabling cache mirroring

In DS4000 Storage Manager, complete the following steps to disable cache mirroring.

**Before you begin:** If write cache is enabled, make backups of all data before disabling cache mirroring.

1. In the Logical/Physical view of the Subsystem Management window, right-click the logical drive on which you want to disable cache mirroring, and select **Change** → **Cache Settings**.

2. In the Change Cache Settings window, clear the *Enable write caching with mirroring* check box.
3. Click **OK**.

**Notes:**

1. When a LUN is opened that is running with write cache enabled and cache mirroring disabled, an FCP array warning message displays. The warning displays again every 24 hours until cache mirroring is enabled again. See FCP\_ARRAY\_ERR25, which is described in “Resolving disk array errors” on page 79.

## Using fast I/O failure for fibre channel devices

I/O failover occurs when a fibre channel adapter driver detects a link failure on the fabric between the switch and the DS4000 storage subsystem. You can change the failover characteristics by setting the fscsi device attribute **fc\_err\_recov** to one of the following settings.

**fast\_fail** Enables fast I/O failure.

If the fibre channel adapter driver detects that a link was lost between the switch and the DS4000, it waits a few seconds to allow the fabric to stabilize. If **fast\_fail** is specified, the adapter then begins failing all I/O at the adapter driver if it detects that the device is not on the fabric. Any new I/O or future retries of the failed I/O are failed immediately.

Fast I/O failure can be useful in multipath configurations. It can decrease the I/O fail times due to the loss of a link between the storage device and the switch, and can allow faster failover to alternate paths.

**delayed\_fail** Default setting.

If **delayed\_fail** is specified, I/O failure proceeds as normal; retries are not immediately failed, and failover takes longer than it does if **fast\_fail** is specified.

In single-path configurations, especially configurations with a single path to a paging device, the **delayed\_fail** setting should be used.

**Example:** You can enable fast I/O failure by setting this attribute, as shown in the following example. Be sure to stop all I/O and put the fscsi device into a Defined state before you set the attribute.

```
chdev -l fscsi0 -a fc_err_recov=fast_fail
```

**Notes:**

1. The **fast\_fail** attribute only affects failover that occurs between the switch and the DS4000 storage subsystem. It does not affect failover that occurs between the host and the switch.
2. Set the **fast\_fail** attribute on each HBA that is configured to the DS4000 storage subsystem.
3. You can use fast I/O failure only in a SAN environment. You cannot use it in a direct-attach environment.

## Using dynamic tracking of fibre channel devices

You can dynamically track fibre channel devices, which allows the dynamic movement of a fibre channel path between the fabric switch and the DS4000 subsystem by suspending I/O for 15 seconds while the move occurs.

**Exception:** You can only use dynamic tracking on AIX 5.2 and 5.3.

You can enable or disable dynamic tracking by setting the fscsi device attribute **dyntrk** to one of the following settings:

**yes** Enables dynamic tracking.

If dynamic tracking is enabled, the fibre channel adapter detects when the fibre channel node port ID of a device changes. It reroutes the traffic that is destined for that device to the new worldwide port name (WWPN) while the devices are still online.

For example, you can move a cable from one switch port to another while the devices are still online, and no failover occurs if you complete the move within 15 seconds. After 15 seconds, failover occurs.

**Tip:** The ports must be in the same zone on the same switch.

**no** Default setting.

If dynamic tracking is not enabled, you must take the devices offline before you move a cable from one port to another. Otherwise, failover occurs.

**Example:** You can enable dynamic tracking by setting this attribute, as shown in the following example. Be sure to stop all I/O and put the fscsi device into a Defined state before you set the attribute.

```
chdev -l fscsi0 -a dyntrk=yes
```

### Notes:

1. Set the **dyntrk** attribute on each HBA that is configured to the DS4000 storage subsystem.
2. You can use dynamic tracking only in a SAN environment. You cannot use it in a direct-attach environment.

## Using dynamic capacity expansion and dynamic volume expansion

Dynamic volume expansion (DVE) is dynamic on the DS4000, but it requires manual intervention for AIX to recognize the new logical drive capacity. This section explains how to use DVE with AIX.

**Exception:** You can only use DVE on AIX 5.2 and 5.3.

**Before you begin:** Ensure that there is available free capacity within the array. You can check free capacity availability using DS4000 Storage Manager, in the Logical/Physical view of the Subsystem Management window. If there is not enough free capacity, and extra drives are available, perform a dynamic capacity expansion (DCE) operation before you perform the DVE operation. A DCE operation increases the capacity of the array by adding physical disks.

### Performing a dynamic capacity expansion operation

Complete the following steps to perform a DCE:



1. In the Logical/Physical view of the Subsystem Management window, right-click the logical drive whose capacity you want to increase, and select **Increase Capacity**. The Increase Logical Drive Capacity—Additional Instructions window opens.
2. Read the additional instructions and click **OK**. The Increase Logical Drive Capacity window opens.
3. Type the amount that you want to increase the logical drive, and click **OK**.

You see an hourglass on every logical drive within the array. You must wait for the process to complete before you can begin any AIX intervention.

**Tip:** If the DS4000 is busy, the process might take several hours to complete.

After you have ensured that there is sufficient free capacity within the array, you can perform DVE, as described in the next topic.

**Requirement:** You must either reboot the system or run the **cfgmgr** command before you can view the additional capacity using the ODM attribute.

### Performing a dynamic volume expansion operation

Complete the following steps to perform a DVE on the AIX host. For more information about expanding Logical VolumeManager (LVM) logical drives, see the man page for the **chvg** command .

1. Unmount the file systems from the LVM logical drive group that has been expanded, by typing the following command:

```
umount mount_point
```

where *mount\_point* is the name of the filesystem that is being unmounted.

2. Change the logical drive group by typing the following command:

```
chvg -g logical drive group name
```

where the *logical drive group name* is the name of the associated LVM logical drive group.

**Note:** If you see a warning that the logical drive group cannot be imported to AIX 5.1 or lower, ignore the warning. It is an error. You can import the logical drive group to AIX 5.1 (or lower.)

3. Mount the file systems.

#### Notes:

1. You might have to run the **varyoffvg** command, and then the **varyonvg** command, on the logical drive group for LVM to see the size change on the disk. However, the new capacity is available for use by the operating system.
2. You cannot resize while the logical drive group is activated in classic or enhanced concurrent mode.
3. You cannot resize the root logical drive group.

---

## Replacing hot swap HBAs

This section describes the procedure for hot-swapping fibre channel host bus adapters (HBAs) on an AIX host.

The hot swap procedure requires knowledge in the following areas:

- AIX administration
- AIX hardware procedures for PCI card replacement.
- IBM System Storage DS4000 Storage Manager
- Fibre channel zoning procedures (required if a switch is used to interconnect DS4000 storage subsystem and the AIX host, and zoning is based on WWPN)

**Caution:** If the procedures are not followed as they are documented in this section, loss of data availability can occur. IBM recommends that you read and understand all of the requirements and steps in this section before you begin the HBA hot swap procedure.

This section contains the following information:

- “Requirements”
- “Known issues and restrictions”
- “Preparing for the HBA hot swap” on page 73
- “Replacing the hot swap HBA” on page 76
- “Mapping the new WWPN to the DS4000 storage subsystem” on page 77
- “Completing the HBA hot swap procedure” on page 77

## Requirements

The following are the minimum AIX operating system and file set versions that are required to support hot swap:

*Table 12. Minimum AIX operating systems and file set versions required for supporting HBA hot swap*

Operating system	Package name	Minimum file set version
AIX 5.1	devices.fcp.disk.array.rte	5.1.0.65
AIX 5.2	devices.fcp.disk.array.rte	5.2.0.60
AIX 5.3	devices.fcp.disk.array.rte	5.3.0.20

## Known issues and restrictions

Please note the following known issues and restrictions when you perform a hot swap operation:

- Caution:** Any deviations from these notes and procedures might cause a loss of data availability.
- The autorecovery attribute of the dar must be set to no. Autorecovery is a dynamically set feature that can be turned back on after the hot swap procedure is complete. Failure to disable autorecovery mode during a hot swap procedure can cause loss of access to data.
  - Do not redistribute logical drives to the preferred path until you verify that the HBA replacement succeeded and that the subsequent configuration was performed correctly. Redistributing the logical drives before verifying successful hot swap and configuration can cause a loss of access to data.

- The only supported hot swap scenario is the following operation:
  - Replacing a defective HBA with the *same* model HBA, and in the *same* PCI slot.

Do not insert the defective HBA into any other system, even if the HBA is found not to actually be defective. Always return the HBA to IBM.

**Important:** No other variations of replacement scenarios are currently supported.

- Hot swap is not supported in single-HBA configurations.

## Preparing for the HBA hot swap

Complete the procedures in this section to prepare for the hot swap.

### Collecting system data

In preparation for the hot swap procedure, complete the following steps to collect data from the system:

1. Type the following command:

```
# lsdev -C |grep fcs
```

The output is similar to the following example:

fcs0	Available 17-08	FC Adapter
fcs1	Available 1A-08	FC Adapter

2. Type the following command:

```
# lsdev -C |grep dac
```

The output is similar to the following example:

dac0	Available 17-08-02	1815	DS4800 Disk Array Controller
dac1	Available 1A-08-02	1815	DS4800 Disk Array Controller

3. Type the following command for each of the fcs devices:

```
# lscfg -vp1 fcsX
```

where *X* is the number of the fcs device. The output looks similar to the following example:

```

iscfg -vpl fcs0
fcs0          U0.1-P1-I1/Q1  FC Adapter

Part Number.....09P5079
EC Level.....A
Serial Number.....1C21908D10
Manufacturer.....001C
Feature Code/Marketing ID...2765
FRU Number.....09P5080
Network Address.....10000000C92D2981
ROS Level and ID.....02C03951
Device Specific.(Z0).....2002606D
Device Specific.(Z1).....00000000
Device Specific.(Z2).....00000000
Device Specific.(Z3).....03000909
Device Specific.(Z4).....FF401210
Device Specific.(Z5).....02C03951
Device Specific.(Z6).....06433951
Device Specific.(Z7).....07433951
Device Specific.(Z8).....20000000C92D2981
Device Specific.(Z9).....CS3.91A1
Device Specific.(ZA).....C1D3.91A1
Device Specific.(ZB).....C2D3.91A1
Device Specific.(YL).....U0.1-P1-I1/Q1

PLATFORM SPECIFIC

Name: fibre-channel
Model: LP9002
Node: fibre-channel@1
Device Type: fcp
Physical Location: U0.1-P1-I1/Q1

```

4. Type the following command:

```
# lsdev -C |grep ^dar
```

The output looks similar to the following example:

```
# dar0      Available      1815      DS4800 Disk Array Router
dar1      Available      1815      DS4800 Disk Array Router
```

5. Type the following command to list the attributes of each dar found on the system:

```
# lsattr -El darX
```

where X is the number of the dar. The output looks similar to the following example:

```
lsattr -El dar0
act_controller   dac0,dac2   Active Controllers           False
all_controller   dac0,dac2   Available Controllers        False
held_in_reset    none        Held-in-reset controller     True
load_balancing   no          Dynamic Load Balancing       True
autorecovery     no          Autorecover after failure is corrected True
hlthchk_freq    600        Health check frequency in seconds True
aen_freq         600        Polled AEN frequency in seconds True
balance_freq     600        Dynamic Load Balancing frequency in seconds True
fast_write_ok    yes         Fast Write available         False
cache_size       1024       Cache size for both controllers False
switch_retries   5          Number of times to retry failed switches True
```

## Verifying that autorecovery is disabled

Before you perform the hot swap, you must complete the following steps to ensure that autorecovery is disabled on every dar that is involved with the HBA you want to hot swap:

1. Identify all the dac(s) that are involved with the HBA by typing the following command:

```
# lsdev -C|grep 11-08
```

The output looks similar to the following example:

```
# lsdev -C|grep 11-08
fcs0      Available 11-08      FC Adapter
fscsi0    Available 11-08-01    FC SCSI I/O Controller Protocol Device
dac0      Available 11-08-01    1742      (700) Disk Array Controller
hdisk1    Available 11-08-01    1742      (700) Disk Array Device
hdisk3    Available 11-08-01    1742      (700) Disk Array Device
hdisk5    Available 11-08-01    1742      (700) Disk Array Device
hdisk7    Available 11-08-01    1742      (700) Disk Array Device
hdisk8    Available 11-08-01    1742      (700) Disk Array Device
```

2. Consult the **lsattr** command output that you collected in step 5 on page 74 of the procedure “Collecting system data” on page 73. In the **lsattr** output, identify the dar(s) that list the dacs you identified in step 1 of this procedure.
3. For each dar that you identified in step 2, type the following command:

```
# lsattr -El darX |grep autorecovery
```

where *X* is the number of the dar. The output looks similar to the following example:

```
# lsattr -El dar0 |grep autorecovery
autorecovery no          Autorecover after failure is corrected True
```

4. In the **lsattr** command output, verify that the second word is **no**. If the second word is set to **yes**, then autorecovery is currently enabled.

**Important:** For each dar on which autorecovery is enabled, you must disable it by setting the autorecovery ODM attribute to **no**. See “Viewing and setting Object Data Manager (ODM) attributes” on page 60 to learn how to change attribute settings. Do not proceed with the hot swap procedure until you complete this step and verify that autorecovery is disabled.

## Replacing the hot swap HBA

After you complete the procedures in “Preparing for the HBA hot swap” on page 73, complete the following steps to replace the hot swap HBA:

1. Place the HBA that you want to replace into the `Defined` state by typing the following command:

```
# rmdev -Rl fcsX
```

where *X* is the number of the HBA. The output is similar to the following example:

```
rmdev -Rl fcs0
fcnet0 Defined
dac0 Defined
fscsi0 Defined
fcs0 Defined
```

2. In the AIX `smit` menu, initiate the process that is required for the HBA hot swap by selecting **smit → Devices → PCI Hot Plug Manager → Replace/Remove a PCI Hot Plug Adapter**.
3. In the Replace/Remove a PCI Hot Plug Adapter window, select targeted HBA. A window displays that contains instructions for replacing the HBA.
4. Replace the HBA by following the `smit` instructions.

**Note:** Do not reinstall the fibre channel cable at this time.

5. If the steps in this procedure are completed successfully up to this point, you obtain the following results:
  - The defective HBA is removed from the system.
  - The replacement FC HBA is powered on.
  - The associated `fcsX` device is in the `Defined` state.

Before continuing, verify that these results have been obtained.

6. Install the fibre channel loop back on the replacement HBA.
7. Place the HBA into the `Active` state by typing the following command:

```
# cfgmgr
```

**Note:** The new HBA is placed in the default group. If the default group has `hdisks` assigned to it then the HBA will generate a new `dar` and `dac`, which will cause a split. Issue the `rmdev` command to remove the new `dar` and `dac` after mapping the WWPN.

8. Verify that the `fcs` device is now available by typing the following command:

```
# lsdev -C |grep fcs
```

9. Verify or upgrade the firmware on the replacement HBA to the appropriate level by typing the following command:

```
# lscfg -vpl fcsX
```

where *X* is the number of the `fcs`.

**Note:** You can determine the HBA firmware level by referring to the `fcsX` device data that you gathered during the procedure at the start of this section, “Collecting system data” on page 73.

- Record the 16-digit number that is associated with Network Address, as it was displayed in the output of the command you used in step 9 on page 76. This Network Address number will be used in the next procedure, manually map the replacement HBA’s WWPN to the Storage subsystem(s).
- Place the HBA back into the Defined state by typing the following command:

```
# rmdev -Rl fcsX
```

When you have completed this procedure, continue to the next procedure, “Mapping the new WWPN to the DS4000 storage subsystem.”

## Mapping the new WWPN to the DS4000 storage subsystem

For each DS4000 storage subsystem that is affected by the hot swap, complete the following steps to map the worldwide port name (WWPN) of the HBA to the storage subsystem:

- Start DS4000 Storage Manager and open the Subsystem Management window.
- In the Mapping View of the Subsystem Management window, select **Mappings** → **Show All Host Port Information**. The Host Port Information window displays.
- Using the data that you collected during the procedure “Collecting system data” on page 73, find the entry in the Host Port Information window that matches the WWPN of the “defective” HBA (the HBA that you removed), and record the alias name. Then, close the Host Port Information window.
- In the Mapping View, select the alias name of the HBA host port that you just recorded.
- Select **Mappings** → **Replace Host Port**. The Replace Host Port window opens.
- In the Replace Host Port window, verify that the current HBA Host Port Identifier, which is listed at the top of the window, exactly matches the WWPN of the HBA that you removed.
- Type the 16-digit WWPN, without the : (colon), of the replacement HBA in the New Identifier field, and click **OK**.

When you have completed these steps continue to the next procedure, “Completing the HBA hot swap procedure.”

## Completing the HBA hot swap procedure

Complete the following steps to finish replacing the hot swap HBA:

- Remove the fibre channel loop back plug, and insert the fibre channel cable that was previously attached to the HBA that you removed.
- If HBA is attached to a fibre channel switch, *and* the zoning is based on WWPN, modify the zoning information to replace the WWPN of the former HBA with the WWPN of the replacement HBA. (Run **cfgmgr** at this time to allow the HBA to register its WWPN in the fibre channel switch.)

**Important:** Skip this step if the HBA is directly attached to the DS4000 subsystem, or if the fibre channel switch zoning is based on port numbers instead of WWPNs. If you do need to modify the zoning, failure to correctly do so will prevent the HBA from accessing the storage subsystem.

- Run the **cfgmgr** command.

4. Type the following commands to verify that the replaced fcsX device and its associated dac(s) are placed in the Available state:

```
# lsdev -C |grep fcs
lsdev -C |grep dac
```

5. Type the following step to verify that no additional dar(s) have been created and that the expected dar(s) are in the Available state. (Refer to the data that you collected during the procedure “Collecting system data” on page 73 to compare the original number of dar(s) to the number that is now reported by the system.)

```
# lsdev -C |grep dar
```

**Caution:** The presence of additional dar(s) in the **lsdev** output indicates a configuration problem. If this occurs, do *not* continue this procedure until you correct the problem, Loss of data availability can occur.

6. For each dar, type the following command to verify that affected dar attributes indicate the presence of two active dac(s):

```
# lsattr -El darX|grep act_controller
```

where X is the number of the dar. The output looks similar to the following:

```
lsattr -El dar0|grep act_controller
act_controller dac0,dac2 Active Controllers False
```

**Caution:** If two dacs are not reported for each affected dar, loss of data availability can occur. Do *not* continue this procedure if two dac(s) are not reported for each dar. Correct the problem before continuing.

7. Using the Storage Manager procedure that is described in “Redistributing logical drives in case of failure” on page 81, manually redistribute volumes to preferred paths.
8. Verify that disks stay on preferred path by using one or both of the following methods:

#### Using AIX system

Run the **fget\_config -Av** command, and verify that drives are on expected path

#### Using Storage Manager

In the Enterprise Management window, verify that the storage subsystem(s) are *Optimal*. If they are not *Optimal*, verify that any drives that are part of the subsystems involved with hot swap process are *not* listed in the Recovery GURU.

9. If necessary, enable autorecovery of the affected dar(s) at this time. (See “Viewing and setting Object Data Manager (ODM) attributes” on page 60 to learn how to change attribute settings.)

**Result:** The fibre channel HBA hot swap is now complete.



---

## Resolving disk array errors

This section shows a list of possible disk array errors that could be reported in the AIX error log. You can view the AIX error log by running the **errpt -a** command.

You can also check your DS4000 Storage Manager Major Event log (MEL) to find out whether there is any correlation between the host, SAN, and DS4000 storage subsystem.

You might need to validate your configuration or replace defective hardware to correct the situation.

**Note:** For more information about troubleshooting, see the Installation, User's and Maintenance Guide for your DS4000 storage subsystem.

- **FCP\_ARRAY\_ERR1** *ARRAY OPERATION ERROR*  
A permanent hardware error involving the disk array media.
- **FCP\_ARRAY\_ERR2** *ARRAY OPERATION ERROR*  
A permanent hardware error.
- **FCP\_ARRAY\_ERR3** *ARRAY OPERATION ERROR*  
A permanent error detected by the array adapter.
- **FCP\_ARRAY\_ERR4** *ARRAY OPERATION ERROR*  
A temporary error within the array, communications, adapter, and so on.
- **FCP\_ARRAY\_ERR5** *UNDETERMINED ERROR*  
An undetermined error has occurred.
- **FCP\_ARRAY\_ERR6** *SUBSYSTEM COMPONENT FAILURE*  
A degradation condition has occurred other than a disk drive.
- **FCP\_ARRAY\_ERR7** *CONTROLLER HEALTH CHECK FAILURE*  
A health check on the passive controller has failed.
- **FCP\_ARRAY\_ERR8** *ARRAY CONTROLLER SWITCH*  
One array controller has become unavailable, so I/O has moved to the other controller.
- **FCP\_ARRAY\_ERR9** *ARRAY CONTROLLER SWITCH FAILURE*  
An array controller switch has failed.
- **FCP\_ARRAY\_ERR10** *ARRAY CONFIGURATION CHANGED*  
A logical unit has been moved from one controller to the other (most likely by the action of an alternate host).
- **FCP\_ARRAY\_ERR11** *IMPROPER DRIVE TYPE FOR DUAL ACTIVE MODE*  
This error should not be possible on the 2102 array, and exists for history reasons only. FCP\_ARRAY\_ERR11 might be reused for a different error in the future.
- **FCP\_ARRAY\_ERR12** *POLLED AEN FAILURE*  
An automatic error notification has failed.
- **FCP\_ARRAY\_ERR13** *ARRAY INTER-CONTROLLER COMMUNICATION FAILURE*  
The controllers are unable to communicate with each other. This could result from one of the controllers being rebooted while the error log was being generated. However, it could be a much more serious error that indicates a problem with the fibre channel connections.
- **FCP\_ARRAY\_ERR14** *ARRAY DRIVE FAILURE*

A serious or unrecoverable error has been detected on a physical disk within the DS4000 subsystem. A system engineer might be able to obtain the exact cause from an analysis of the sense data.

- **FCP\_ARRAY\_ERR15** *CACHE BATTERY LOW/DATA LOSS POSSIBLE*  
If a controller card is replaced, it is likely that the cache batteries will be flat. It can take two days for the cache batteries to be fully recharged. During this time errors are logged in the error log. Do not replace the controller.
- **FCP\_ARRAY\_ERR16** *CACHE BATTERY CHARGE BELOW 87.5%*  
If a controller card is replaced, it is likely that the cache batteries will be flat. It can take two days for the cache batteries to be fully recharged. During this time errors are logged in the error log. Do not replace the controller.
- **FCP\_ARRAY\_ERR17** *WORLDWIDE NAME CHANGED*  
A controller has changed worldwide names (most likely either it was replaced without placing it in the reset state first, or the cabling was changed so that a different controller with the same SCSI ID is on the loop).
- **FCP\_ARRAY\_ERR18** *RESERVATION CONFLICT*  
An operation failed because the disk array logical drive (LUN) is reserved by another host.
- **FCP\_ARRAY\_ERR19** *SNAPSHOT VOLUME'S REPOSITORY FULL*  
The repository capacity limit has been reached. To resolve this error you can increase the repository capacity.
- **FCP\_ARRAY\_ERR20** *SNAPSHOT OPERATION STOPPED BY ADMIN*  
The FlashCopy (snapshot) operation has been disabled or stopped. To resolve this error you can recreate the FlashCopy.
- **FCP\_ARRAY\_ERR21** *SNAPSHOT REPOSITORY METADATA ERROR*  
There was a problem with the metadata of the FlashCopy (snapshot) repository during the FlashCopy operation. To resolve this error you can recreate the FlashCopy.
- **FCP\_ARRAY\_ERR22** *REMOTE VOL MIRRORING: ILLEGAL I/O ORIGIN*  
The primary logical drive received I/O from a remote array, or the secondary logical drive received I/O from other than the primary logical drive. To resolve this error you can try the operation again.
- **FCP\_ARRAY\_ERR23** *SNAPSHOT OPERATION NOT ALLOWED*  
The repository capacity limit has been reached, so the FlashCopy (snapshot) operation has failed. To resolve this error you can delete or recreate the FlashCopy.
- **FCP\_ARRAY\_ERR24** *SNAPSHOT VOLUME'S REPOSITORY FULL*  
The repository capacity limit has been reached. To resolve this error you can delete or recreate the FlashCopy (snapshot).
- **FCP\_ARRAY\_ERR25** *CACHED DATA WILL BE LOST IF CONTROLLER FAILS*  
This message is a warning that a disk array logical drive (LUN) is running with write cache enabled and cache mirroring disabled. The warning displays when the LUN is opened, and it displays again every 24 hours until cache mirroring is enabled again.  
  
If a controller failure or a power down occurs while the LUN is running in this mode, data that is in the write cache (but not written to the physical disk media) might be lost. This can result in corrupted files, file systems, or databases.
- **FCP\_ARRAY\_ERR26** *LOGICAL VOLUME IS WRITE PROTECTED*

The status of the logical drive is read-only. The probable reason is that it is a secondary logical drive of a FlashCopy, VolumeCopy, or remote mirror pair. Check which relationship applies to the logical drive.

- For FlashCopy, a status of read-only on the secondary logical drive usually indicates that the repository is full.
- For VolumeCopy, both the primary and secondary logical drives are read-only during the copy. The secondary logical drive is read-only when the copy is stopped but the copy pair had not been deleted.
- For remote mirroring, the secondary logical drive is always read-only, as long as the mirror is active.

• **FCP\_ARRAY\_ERR27 SINGLE CONTROLLER RESTARTED**

The subsystem is operating as a single controller, and an error has been repaired. The error might have been a communication or hardware problem, or it might have occurred because a LUN was moved to a controller that does not have a path to the current host

If this is a dual-controller subsystem, find the reason that the subsystem is operating in single-controller mode, and resolve the problem. Possible reasons include:

- An HBA, switch port, switch, DS4000 port or DS4000 controller was unavailable during the last system reboot or the last time the **cfgmgr** command was run.
- A user removed a path (dac) as part of a fibre channel adapter hot swap operation.

• **FCP\_ARRAY\_ERR28 SINGLE CONTROLLER RESTART FAILURE**

The subsystem is operating as a single controller, and the error has not been repaired. There is a problem with the path between this host and the subsystem or with the subsystem itself. The host has attempted to communicate with the subsystem and that communication has failed.

If the number of retries that is specified in the ODM attribute *switch\_retries* is reached, the I/O is failed back to the user.

Repair the error. Then, if this is a dual-controller subsystem, find the reason that the subsystem is operating in single-controller mode, and resolve that problem. Possible reasons include:

- An HBA, switch port, switch, DS4000 port or DS4000 controller was unavailable during the last system reboot or the last time the **cfgmgr** command was run.
- A user removed a path (dac) as part of a fibre channel adapter hot swap operation.

---

## Redistributing logical drives in case of failure

If you enabled autorecovery on the AIX host, you do not need to redistribute logical drives manually after a controller failover. However, if you have a heterogeneous host environment, you might need to redistribute logical drives manually. Hosts that do not support some form of autorecovery, or AIX hosts that have autorecovery disabled, will not automatically redirect logical drives to the preferred paths.

Complete the following steps to manually redistribute logical drives to their paths:

1. Repair or replace any faulty components. For more information, see the Installation, User's and Maintenance Guide for the appropriate DS4000 storage subsystem.

- Using the Subsystem Management window, redistribute logical drives to their preferred paths by clicking **Advanced** → **Recovery** → **Redistribute Logical Drives**.

**Note:** If a large number of LUNs is configured on the DS4000 system, redistributing logical drives might take 60 minutes or more to complete, depending on how busy the system is.

- Run the **fget\_config** command to verify the active paths, as shown in this example:

```
# fget_config -l dar0
dac0 ACTIVE dac1 ACTIVE
dac0-hdisk1
dac0-hdisk2
dac0-hdisk3
dac1-hdisk4
dac1-hdisk5
dac1-hdisk6
dac1-hdisk7
dac0-hdisk8
```

---

## Chapter 3. Installing and configuring storage management software on HP-UX host systems

This chapter provides the following information for HP-UX operating systems:

- “HP-UX system requirements”
- “Installing DS4000 Storage Manager” on page 84
- “Configuring storage subsystems” on page 90
- “Creating storage partitions” on page 95
- “Creating direct-attached and SAN-attached configurations” on page 99
- “Enabling multipath I/O with PV-links” on page 100
- “Redistributing logical drives in case of failure” on page 105

---

### HP-UX system requirements

This section lists the minimum hardware and software requirements for an HP-UX host in a DS4200, DS4300, DS4400, DS4500, DS4700 or DS4800 storage subsystem that is managed by DS4000 Storage Manager 10.10.

#### Hardware requirements

The HP-UX system must be an HP 9000/Series 800 server with:

- 440 MHz processor or faster
- 1 GB memory
- 0.7 MB available on /opt and root (or root-equivalent) privileges for installing SMutil and SMagent
- 47.5 MB available disk space on /opt and at least 95 MB available on /tmp for installation in an SMruntime environment

#### Software requirements

Ensure that the HP-UX host is running one of the following operating systems with the appropriate patches. Because patch levels can be superseded by more recent versions, refer to your operating system documentation or contact your operating system supplier to ensure that you have the correct patches.

- HP-UX 11.0 (64 bit) with the following patches, at minimum:
  - PHKL\_23939
  - PHKL-27003
  - PHKL\_24027
  - PHKL\_27364
  - To run HP-UX SDK for Java 2 Platform applications and applets using GUIs, you must also ensure that the HP C++ runtime libraries are installed on the HP-UX system; the latest version is available as patch PHSS\_1658
- HP-UX 11.i (64 bit):
  - Operating System base: B.11.11
  - Minimum patch level: December '04
- HP-UX 11.23:
  - Operating System base: B.11.13
  - Minimum patch level: September '04

- For high-availability clusters of HP 9000/Series 800 computers, install the HP MC/Service Guard software package.

Ensure that the following maximum kernel parameters are configured, as shown in Table 13.

*Table 13. HP-UX kernel parameter configuration requirements*

Parameter	Description	Configuration
max_thread_proc 64	Maximum threads per process	1024
maxfiles	Soft-file limit per process	2048
maxuser	Influences other parameters	256 or greater
ncallout	Number of pending timeouts	4144

**Note:** Updated readme files contain important configuration information that supersedes this document. To access the most recent DS4000 Storage Manager readme file for HP-UX, see “Finding the Storage Manager readme files online” on page 24.

---

## Installing DS4000 Storage Manager

The DS4000 Storage Manager software includes the following software packages:

### **SMruntime (required)**

SMruntime is a Java compiler for the DS4000 Storage Manager software packages. SMruntime must be installed before the other packages are installed.

### **SMesm (required if installing SMclient)**

SMesm is the mechanism for delivering ESM firmware, which contains a defined set of ESM firmware files that are used by the auto-sync mechanism.

### **SMclient (optional)**

SMclient is Storage Manager’s graphical user interface (GUI), which you use to manage your storage subsystems. If you are not using your HP-UX host as a storage management station (for example, if you are using a Windows management station with SMclient installed), then you do not need to install SMclient on your HP-UX host.

### **SMagent (optional)**

SMagent contains host-agent software, which you can use to manage your subsystems if you are using an in-band management configuration (managing the storage subsystems through the fibre channel I/O path to the host). If you are using an out-of-band management configuration, you do not need to install SMagent.

### **SMutil (required)**

SMutil is a utility that you can use to register and map new logical drives to the operating system. SMutil is required on HP-UX host systems.

You can install all of the DS4000 Storage Manager software packages automatically by using the Storage Manager installation wizard, or you can install each package manually. This section contains the following procedures:

- “Installing Storage Manager using the installation wizard” on page 85
- “Installing Storage Manager packages manually” on page 86 (original method)

## Installing Storage Manager using the installation wizard

The DS4000 Storage Manager installation wizard can install all of the Storage Manager software packages automatically. If you prefer, you can install just the following required packages onto your HP-UX host:

- SMruntime
- SMutil

To choose the packages that you want to install, select Custom Installation during the installation procedure, as described in “Steps for installing Storage Manager using the installation wizard.”

### Installation wizard requirements

To use the installation wizard, you must meet the following requirements:

- You are installing DS4000 Storage Manager 10.10
- Your HP-UX host has a graphics adapter card installed.

If you are installing Storage Manager 10.10 on HP-UX and your system does not meet the requirements for using the wizard, does not have a graphics card installed, or if you do not want to use the wizard to install the software, you can perform the installation without a GUI by typing the `sh <installer-package-name.bin> -i console` command in the command line interface. You can also skip this section and install the stand-alone host software packages using the procedures described in “Installing Storage Manager packages manually” on page 86. All the packages are included with the installation CD.

### Notes:

1. Installing Storage Manager 9.12, or a later version, can be done either with the installation wizard or manually. It is recommended, however, that for versions 9.12 or higher, you use the installation procedure described in “Installing Storage Manager using the installation wizard.”
2. Do not install the software packages in the same server by using both the installation wizard and the manual installation method.

### Steps for installing Storage Manager using the installation wizard

Complete the following steps to install the DS4000 Storage Manager software using the installation wizard. Adjust the steps as necessary for your specific installation.

1. Download the following file from the DS4000 Storage Manager CD, or from the DS4000 support Web site, to a directory on your system:  
SMIA-HPUX-10.10.xx.xx.bin
2. Open the file on your system. The Storage Manager Installation wizard's Introduction window opens.
3. Follow the instructions in each window of the wizard. When you select the installation type, you can choose one of the following options:
  - Typical (Full) Installation—Installs all Storage Manager software packages
  - Management Station—Installs SMruntime and SMclient
  - Host—Installs SMruntime, SMagent and SMutil
  - Custom—Allows you to select which packages you want to install
4. Restart the system.

**Result:** The DS4000 Storage Manager software is installed on your system.

## Installing Storage Manager packages manually

Use the following procedures, in the order listed, to install DS4000 Storage Manager 10.10 (or earlier) software on an HP-UX storage management station or on an HP-UX host acting as a storage management station.

1. “Installing the client software”
2. “Installing the host software” on page 88

### Installing the client software

For the specific installation order, see Table 3 on page 5.

**Note:** SMclient is dependent on SMruntime, which is a Java compiler for the SMclient. SMruntime must be installed first. If you do not install SMruntime you will receive errors during the software install analysis phase.

**Prerequisites:** Before installing the client software, ensure that the following conditions are met:

- This is the HP 9000-series server that you identified as the storage management station.
- This machine meets the minimum hardware and software requirements described in Appendix A, “MC/Service Guard configuration details,” on page 221.
- Neither the SMruntime software nor the SMclient software is installed on the host and you are ready to install them on this machine.
- The DS4000 Storage Manager installation files are available in a directory on the system.

**Steps for installing SMruntime software (required):** Modify the commands as needed for your installation. No restart is required during the SMruntime installation process.

1. Insert the HP-UX installation CD in the CD-ROM drive.
2. Start the installation process by typing the following command:

```
# mount -o cdcase -F cdfs /path_name /cdrom
# swinstall -s /cdrom/HP-UX/SMruntime_10xxxxx
```

where *path\_name* is the directory path to the SMruntime package.

The Software Selection window opens and displays this message:

```
SMruntime
```

3. Select **SMruntime**.
4. Click **Actions** → **Mark for installation**.
5. Click **Actions** → **Install (Analysis)**.
6. Click **OK** when the analysis is finished.
7. In the confirmation window, click **Yes** to start the installation.
8. When the application is finished, click **Done** in the Installation window and close the application.

**Note:** You must exit the **swinstall** command before running the **swverify** command to verify the installation.

9. Verify that the installation was successful by typing the following command:

```
# swverify -v SMruntime
```



If no failure is reported, the SMruntime installation has successfully completed.  
If a failure is reported, follow the instructions in the /var/adm/sw/swagent.log file.

**Result:** The SMruntime installation of this HP-UX storage management station is complete.

**Steps for installing SMesm software (required if installing SMclient):** If you are using your HP-UX host as a storage management station, then you must install SMesm on the host. If you are using a different computer as your storage management station, install SMesm on that computer.

Modify the commands as needed for your installation. No restart is required during the SMesm installation process.

1. Start the installation process by typing the following command:

```
# swinstall -s /cdrom/HP-UX/SMesm-HP-10xxxxx
```

The Software Selection window opens and displays the following message:

```
SMesm
```

2. Select **SMesm**.
3. Click **Actions** → **Mark for installation**.
4. Click **Actions** → **Install (Analysis)**
5. Click **OK** when the analysis is finished.
6. In the Confirmation window, click **Yes** to start the installation.
7. When the application is finished, click **Done** in the Installation window and close the application.

**Note:** You must exit the **swinstall** command before running the **swverify** command to verify installation.

8. Verify that the installation was successful by typing the following command:

```
# swverify -v SMesm
```

If no failure is reported, you are done installing SMesm. If a failure is reported, follow the instructions in the /var/adm/sw/swutil.log file.

**Result:** The SMesm installation of this HP-UX storage management station is complete.

**Note:** To ensure redundancy in a cluster environment, you must install SMesm on at least one additional storage management station or cluster server.

**Steps for installing SMclient software (optional):** If you are using your HP-UX host as a storage management station, then you must install SMclient on the host. If you are using a different computer as your storage management station, install SMclient on that computer.

Modify the commands as needed for your installation. No restart is required during the SMclient installation process.

1. Start the installation process by typing the following command:

```
# swinstall -s /cdrom/HP-UX/SMclient-HP-10xxxxx
```

The Software Selection window opens and displays the following message:

```
SMclient
```

2. Select **SMclient**.
3. Click **Actions** → **Mark for installation**.
4. Click **Actions** → **Install (Analysis)**
5. Click **OK** when the analysis is finished.
6. In the Confirmation window, click **Yes** to start the installation.
7. When the application is finished, click **Done** in the Installation window and close the application.

**Note:** You must exit the **swinstall** command before running the **swverify** command to verify installation.

8. Verify that the installation was successful by typing the following command:

```
# swverify -v SMclient
```

If no failure is reported, you are done installing SMclient. If a failure is reported, follow the instructions in the `/var/adm/sw/swutil.log` file.

**Result:** The SMclient installation of this HP-UX storage management station is complete.

**Note:** To ensure redundancy in a cluster environment, you must install SMclient on at least one additional storage management station or cluster server.

### Installing the host software

If you are installing the optional SMagent, install the host software in the following order. If you are not installing SMagent, then SMutil is the only DS4000 Storage Manager host software that you need to install.

- DS4000 SMagent software (optional—for in-band management only)
- DS4000 SMutil software (required)

**Note:** SMagent and SMutil are dependent on SMruntime, which is a Java compiler for the DS4000 Storage Manager software and must be installed first. If you do not install SMruntime you receive errors during the software install analysis phase.

**Prerequisites:** Before installing the host software, ensure that the following conditions are met:

- This is the HP 9000-series server that you identified as the storage management station.
- This machine meets the minimum hardware and software requirements described in Appendix A, “MC/Service Guard configuration details,” on page 221.
- SMruntime has been installed.

**Note:** SMagent is not supported with DS4000 controller firmware version 5.42.xx.xx.

**Steps for installing SMagent software (optional):** SMagent is required for in-band management only. It is not required for out-of-band management.

Modify the commands as needed for your installation. No restart is required during the SMagent installation process.

1. Start the installation process by typing the following command:

```
# swinstall -s /cdrom/HP-UX/SMagent-HP-10xxxxxx
```

The Software Selection window opens and displays this message:

```
SMagent
```

2. Select **SMagent**.
3. From the toolbar, click **Actions → Mark for installation**.
4. Click **Actions → Install (analysis)**.
5. Click **OK** when the analysis is finished.
6. In the Confirmation window, click **Yes** to start the installation.
7. When the installation is finished, click **Done** in the Installation window and close the application.

**Note:** You must exit the **swinstall** command before running the **swverify** command to verify the installation.

8. Verify that the installation was successful by typing the following command:

```
# swverify -v SMagent
```

If no failure is reported, you are done installing SMagent. If a failure is reported, follow the instructions in the `/var/adm/sw/swagent.log` file.

**Result:** The SMagent installation on this HP-UX storage management station is complete.

**Steps for installing SMutil software (required):** Modify the commands as needed for your installation. No restart is required during the SMutil installation process.

1. Start the installation process by typing the following command:

```
# swinstall -s /cdrom/HP-UX/SMutil_10xxxxxx
```

The Software Selection window opens and displays this message:

```
SMutil
```

2. Select **SMutils**.
3. Click **Actions → Mark for Installation**.
4. Click **Actions → Install (Analysis)**.
5. Click **OK** when the analysis is finished.
6. In the Confirmation window, click **Yes** to start the installation.
7. When the application is finished, click **Done** in the Installation window and close the application.

**Note:** You must exit the **swinstall** command before running the **swverify** command to verify the installation.

8. Verify that the installation was successful by typing the following command:

```
# swverify -v SMutil
```

If no failure is reported, you are done installing SMutil. If a failure is reported, follow the instructions in the `/var/adm/sw/swutil.log` file.

**Result:** The SMutil installation of this HP-UX storage management station is complete.

---

## Configuring storage subsystems

After you install DS4000 Storage Manager, you need to configure the subsystem. System configuration includes configuring logical drives and creating storage arrays using the Subsystem Management window of DS4000 Storage Manager.

See “Configuring storage subsystems” on page 201 for additional information about storage configuration.

**Before you begin:** Note the following information:

- All DS4000 storage subsystems have an access logical drive set to LUN 31.

**Note:** Do not delete the access LUN or the access logical drive.

- AVT/ADT is enabled by default; leave it in that state for HP-UX hosts.
- Versions of controller firmware and NVSRAM that come with this product might be later releases than those described in this document. To ensure that you have the latest versions of the firmware and the NVSRAM, read the Storage Manager readme file for HP-UX that is provided with the product. See “Finding the Storage Manager readme files online” on page 24.

**Note:** If you do not have the latest versions of controller firmware and NVSRAM, download them and complete the procedure described in “Upgrading controller firmware and NVSRAM” on page 91. If the version numbers are current, you can skip that procedure.

- If you have purchased a Storage Partitioning premium feature, ensure that the feature is enabled. See “Enabling premium features” on page 18 for more information.

Complete the following procedures to configure DS4000 Storage Manager for an HP-UX system.

## Adding storage subsystems to SMclient

Complete the following steps to add storage subsystems to SMclient:

1. To set up the storage subsystem for HP-UX, the subsystem must be physically configured, at least initially, for direct management through the Ethernet connections on each controller as well as through the fibre channel connection. Install the DS4000 Storage Manager software (SMruntime, SMclient, SMagent, and SMutil) before configuring the subsystem.
2. After the disk subsystem is configured on the network, type the following command to run SMclient on either the host server, if it is on the same network as the storage subsystem, or on another machine in the network that has the DS4000 Storage Manager software installed:

```
# SMclient
```

3. Complete the following steps to specify the IP addresses of the controllers:
  - a. In the Enterprise Management window, click **Edit → Add Storage Subsystem**.
  - b. In the Add Storage Subsystem window, type the IP addresses of each controller in the storage subsystem, and click **Add**. The name of the storage subsystem displays in the Enterprise Management window.

**Note:** Failure to add both controllers results in a partially-managed system.

4. In the Enterprise Management window, double-click the name of the storage subsystem to open its Subsystem Management window.
5. In the Subsystem Management window, click **Storage Subsystem → View Profile** and review the summary portion of the output.

## Upgrading controller firmware and NVSRAM

The procedures in this section describe how to download and install DS4000 controller firmware and NVSRAM.

### Notes:

1. If you are upgrading a DS4800, DS4700, or a DS4200 storage subsystem to controller firmware version 07.10.xx.xx, see Appendix D, “Using the IBM System Storage DS4000 Controller Firmware Upgrade Tool,” on page 235.
2. Upgrading to 07.10.xx.xx cannot be done concurrently.

### Overview

Read the information in the following sections before you begin the download procedures:

- “Using concurrent download”
- “Using traditional or staged download”

**Using concurrent download:** Depending on your system’s current firmware, you might be able to use *concurrent download*. Concurrent download is a method of downloading firmware to the controllers that does not require you to stop I/O to the controllers during the process.

**Note:** Some controller firmware versions might not support concurrent download. See the latest Storage Manager readme file for HP-UX to find out which firmware versions support concurrent download.

**Using traditional or staged download:** There are two methods for downloading the firmware to the controllers:

- “Traditional download”
- “Staged download”

**Traditional download:** The traditional download process takes significantly longer and must be done in one phase, rather than in two phases as with the staged controller firmware download. Therefore the preferred method of controller firmware download is the staged controller firmware download.

**Staged download:** With staged firmware download, the download process occurs in two distinct phases: firmware transfer and firmware activation. You can perform the time-consuming task of loading the firmware online so that it is functionally transparent to the application. You can then defer the activation of the loaded firmware to a convenient time.

Some reasons for activating firmware files at a later time include the following:

- **Time of day**—Activating can take a long time, so you might want to wait until I/O loads are lighter because the controllers will go offline briefly to activate the new firmware.
- **Type of package**—You might want to test the new firmware package on one storage subsystem before activating it on other storage subsystems.
- **Multiple controllers**—You can download controller firmware from the storage management software to all storage subsystem controllers for later activation.

**Notes:**

1. You cannot use staged download to upgrade DS4000 controller firmware version 05.xx.xx.xx to version 06.xx.xx.xx or version 07.10.xx.xx. You can only use staged download if the DS4000 controller firmware version is already 06.xx.xx.xx or higher, and you are downloading another version of 06.xx.xx.xx firmware or higher.
2. Staged controller firmware download is not supported on DS4400 storage subsystems.

**Important:** Do not perform other storage management tasks, such as creating or deleting logical drives, reconstructing arrays, and so on, while downloading the DS4000 storage subsystem controller firmware. It is recommended that you close all storage management sessions (except for the session that you use to upgrade the firmware) to the DS4000 storage subsystem that you plan to update. Also, the subsystem must be in Optimal state prior to loading firmware or NVSRAM.

## Preparing for firmware or NVSRAM download

To prepare for download, review and complete all of the steps in this section before you start the download procedures.

**Check current versions of controller firmware and NVSRAM:** Versions of controller firmware and NVSRAM that are provided with this product might be later releases than those described in this document.

To check the controller firmware and NVSRAM versions that are currently installed on your system, complete the following steps:

1. In the Subsystem Management window, click **Storage Subsystem → View Profile**. The Storage Subsystem Profile window displays.
2. In the Storage Subsystem Profile window, click the **Controllers** tab to view the current versions of controller firmware and NVSRAM.
3. Click **Close** to close the Storage Subsystem Profile window.
4. To find whether the versions of controller firmware and NVSRAM that are currently on your storage subsystem are the latest versions, read the Storage Manager readme file. The latest versions are listed in the readme file. (See “Finding the Storage Manager readme files online” on page 24.)
5. If you find that you do not have the latest versions of the firmware and NVSRAM, download the correct versions from this Web site to a directory on your system, then follow the preparation and upgrade procedures that are described in this section.

**Save the storage subsystem configuration:** Saving the storage subsystem configuration to a script file is necessary in order to restore the configuration in the event of a catastrophic failure.

**Attention:** Do not use this option if the storage subsystem is undergoing an operation that changes any configuration settings. (If any logical drive listed in the Logical View of the Subsystem Management window has a clock icon, then a configuration change is occurring, and you must wait to save the configuration.)

You can also save the storage subsystem profile, by selecting **Storage Subsystem** → **View Profile** in the Subsystem Management window, and clicking **Save As**. Then, in the Save Profile window, select the sections of the profile that you want to save, specify a name and location for the text file, and click **Save**.

Save the storage subsystem configuration by completing the following steps:

1. In the Subsystem Management window, click **Storage Subsystem** → **Configuration** → **Save**. The Save Configuration window displays.
2. In the Save Configuration window, select the elements of the configuration that you want to save, and click **Yes**. A save dialog displays.
3. In the save dialog, specify a name for the script file and select its location.

**Notes:**

- a. The .cfg extension is used by default for the script file if you do not specify a file extension.
  - b. Do not store your DS4000 Storage Subsystem configuration script file in the same location as the logical drives that are defined on your DS4000 Storage Subsystem. If you do this, and the logical drives fail during the subsequent migration, you will lose data.
4. Click **Save**. The Configuration Saved window displays.
  5. Review the information in the Configuration Saved window, then click **OK** to return to the Subsystem Management window.

**Determine whether you need to stop I/O:** You can use concurrent download only if you are upgrading from one version of controller firmware to a later release of the same version. For example, if you are upgrading from 06.10.xx.xx to 06.2x.xx.xx, you can use concurrent download. However, if you are upgrading from 05.xx.xx.xx to 06.2x.xx.xx, you *cannot* use concurrent download.

**Notes:**

1. Some controller firmware versions might not support concurrent download. See the latest Storage Manager readme file for HP-UX to find out which firmware versions support concurrent download.
2. Single-controller (SCU) storage subsystem models do not support concurrent download.

In addition, before you upgrade controller firmware, ensure that concurrent download is supported with your system's current firmware versions, using the information that is listed in Table 14.

Table 14. Firmware versions that support concurrent download (HP-UX)

DS4000 storage subsystem:	Controller firmware version:
DS4100	06.10.xx.xx, 06.12.xx.xx
DS4200	06.16.88.xx, 06.23.xx.xx, 06.60.xx.xx, 07.10.xx.xx
DS4300 base and Turbo	06.10.xx.xx, 06.12.xx.xx, 06.19.xx.xx, 06.60.xx.xx
DS4400	06.10.xx.xx, 06.12.xx.xx

Table 14. Firmware versions that support concurrent download (HP-UX) (continued)

DS4000 storage subsystem:	Controller firmware version:
DS4500	06.10.xx.xx, 06.12.xx.xx, 06.19.xx.xx, 06.60.xx.xx
DS4700	06.16.xx.xx, 06.23.xx.xx, 06.60.xx.xx, 07.10.xx.xx
DS4800	06.16.xx.xx, 06.23.xx.xx, 06.60.xx.xx, 07.10.xx.xx
All other DS4000 storage subsystems	05.30.xx.xx, 06.10.xx.xx, 06.12.xx.xx

## Steps for upgrading the controller firmware

Complete the following steps to install a new firmware version on the controllers:

1. Download the correct version of the firmware from the Web site that is listed in “Check current versions of controller firmware and NVSRAM” on page 92. Place the file in a designated directory on the host system.
2. Check your system’s current firmware versions to determine whether you need to stop I/O before upgrading the firmware, using the information that is listed in Table 14 on page 93.  
**Attention:** Some controller firmware versions might not support concurrent download. See the latest Storage Manager readme file for HP-UX to find out which firmware versions support concurrent download.
3. Ensure that the array is in an Optimal state. If it is not, resolve the issue before continuing to the next step.
4. In the Subsystem Management window, click **Advanced** → **Maintenance** → **Download** → **Controller Firmware**. The Download Firmware window displays.
5. Click **Browse** to select the firmware file that you previously downloaded to a directory on the host.
6. If you want to perform a staged firmware download, select the check box next to “Transfer files but don’t activate them (activate later).” If you want to perform a traditional firmware download, do not select the check box, and the firmware will load immediately.
7. Click **OK**. The Confirm Download window displays.
8. Click **Yes** to start the download.
9. Verify that the firmware was successfully installed.
10. After you verify that the firmware was successfully installed, then you can restart I/O to the subsystem.

## Steps for upgrading the NVSRAM

Complete the following steps to install a new version of NVSRAM on the controllers. NVSRAM will be activated immediately.

1. Download the correct NVSRAM version from the Web site that is listed in “Check current versions of controller firmware and NVSRAM” on page 92. Place the file in a designated directory on the host system.
2. Stop I/O.
3. Ensure that the array is in an Optimal state. If it is not, resolve the issue before continuing to the next step.
4. In the Subsystem Management window, click **Advanced** → **Maintenance** → **Download** → **Controller NVSRAM**. The Download NVSRAM window displays.
5. Click **Browse** to select the NVSRAM file that you previously downloaded to a directory on the host.
6. Click **OK**. The Confirm Download window displays.
7. Click **Yes** to start the download.



8. Verify that the NVSRAM was successfully installed.
9. Start I/O.

---

## Creating storage partitions

To create storage partitions, you must complete the following procedures in this section:

1. “Steps for defining an HP-UX host group”
2. “Steps for defining the host and host port” on page 96
3. “Mapping LUNs to a storage partition” on page 97

## Storage partitioning overview

When you begin to create your storage partitions using the procedures in this section, be aware of the following information:

- If your subsystem is running controller firmware 06.12.xx.xx or higher, the Storage Manager task assistant provides a Storage Partitioning wizard that you can use to define your host and host ports, and map LUNs to the storage partitions. If your subsystem is running controller firmware 05.xx.xx.xx, you cannot use the wizard. Both types of procedures are documented in this section.
- The procedures in this section assume that you have already created a physical connection between the host and the storage subsystem controllers, and that you have also connected and zoned the SAN switch (if any). If you have not completed these connections, please note that Storage Manager will *not* be able to list the WWPNs of the HBAs during these procedures. In this case you will need to type the WWPNs into the appropriate fields during the steps for defining a host and host ports.
- Create the HP-UX host group at the storage subsystem level. Do not create host groups at the default group level.

**Exceptions:** If you are running a DS4300 configuration without partitioning enabled, you can use the default host group.

**Before you begin:** Identify the worldwide port name for each of your HBAs. Look for the worldwide port name for the HBA and write down the number for future reference. Use the following command to find your HBAs listed in the dev directory as td0, td1, and so on, where *X* in the following example represents the td number.

```
#cd /dev/td
#tdutil /dev/tdX
```

## Steps for defining an HP-UX host group

A *host group* is an entity in the Storage Partitioning topology that defines a logical collection of host computers that require shared access to one or more logical drives. You can grant individual hosts in a defined host group access to storage partitions, independently of the host group.

Complete the following steps to define a host group:

1. Click the **Mappings View** tab on the Subsystem Management window.
2. In the Topology section of the Mappings window, highlight the name of the storage subsystem, and click **Mappings** → **Define** → **Host Group**.

**Note:** Make sure that the storage subsystem is highlighted in the left panel of the Subsystem Management window. Do not highlight Undefined Mappings.

3. Type the name of the new host group (for example, HP-UX). Click **Add**, and then click **Close**.

## Steps for defining the host and host port

Complete the steps that are appropriate for your storage subsystem controller firmware type:

- “Controller firmwares 07.10.xx.xx and 06.xx.xx.xx” on page 41
- “Controller firmware 06.12.xx.xx and later”
- “Controller firmware 05.xx.xx.xx” on page 97

### Controller firmware 07.10.xx.xx

If your subsystem has controller firmware 07.10.xx.xx installed, complete the following steps to define the host and host ports by using the **Define a host and host ports** wizard:

1. In the Mappings tab, right-click on the desired host group and select **Define → Host**.
2. Select **Yes**, if using the partitioning feature.
3. Select either the correct WWPN or the HBA host port(s) for the new host..
4. One-at-a-time, select the WWPNs for the host, and click **Edit** to give them aliases (for example, Host\_A, Host\_B).
5. Click **Next**.
6. If using the partitioning feature, click the dropdown box to select OS type.

**Note:** Failure to change the host type from the default to HP-UX will cause undesired results.

7. Click **Next**.
8. Select **Yes** if you intend host to share LUNS with others in a host group; otherwise, select **No**. (If you select Yes, you will be prompted to enter a new hostgroup name or to specify an existing one.)
9. Click **Next** and **Finish** to exit the wizard.

### Controller firmware 06.12.xx.xx and later

If your subsystem has controller firmware 06.12.xx.xx or later installed, complete the following steps to define the host and host ports by using the **Define a host and host ports** wizard:

1. In the Topology section of the Mappings view of the Subsystem Management window, right-click the new host group and select **Define Host**. The **Introduction (Define Host)** window opens.
2. Click **Next**. The **Specify Host Name/HBA Attribute (Define Host)** window opens.
3. Type the host name in the **Specify Host Name/HBA Attribute (Define Host)** window. In the left panel, select the correct WWPN of the HBA host port. Click **Add**.

**Note:** If you there is not yet a physical connection between the host and the DS4000 controllers, as described in the “Storage partitioning overview” on page 95, the WWPNs will not display. In this case, you must type the correct WWPN into the field.

4. You must now provide an alias name for the host port. Click **Edit**, then type an alias name (for example, Port1).
5. On configurations with two or more HBAs, repeat step 3 on page 96 and step 4 for each host port that you need to define, then proceed to step 6.
6. Click **Next**. The **Specify Host Type** window opens.
7. Select the correct host type, HP-UX, from the drop down menu and click **Next**. The **Review** window opens.

**Note:** Failure to change the host type from the default to HP-UX will cause undesired results.

8. Review the information for accuracy, and make any necessary changes. Then click **Next**.

**Recommendation:** Record the name of each host port along with the WWPN of its corresponding HBA, and save the information to a file for future reference.

9. After Storage Manager finishes defining the host and host ports, a dialog window opens. If you need to define another host, select **Define another host**. To finish, click **Exit**. The wizard closes.

### Controller firmware 05.xx.xx.xx

If your subsystem has controller firmware 05.xx.xx.xx installed, complete the following steps to define a host and host ports.

**Note:** IBM recommends upgrading your controllers to the latest controller firmware that is available for your storage subsystem.

1. In the Topology section of the Mappings view of the Subsystem Management window, highlight the new host group and click **Mappings** → **Define** → **Host**.
2. Define the new host. Type the name of the HP-UX host to which the storage subsystem is attached.
  - a. Click **Add**, and then click **Close**.
  - b. Highlight the host that you just added, then right-click and select **Define Host Port**.
  - c. Type or select the desired host port for the first HBA, and then change the host type to **HP-UX**. Click **Add**.

**Note:** Failure to change the host type from the default to HP-UX will cause undesired results.

- d. If you are configuring additional HBAs to this partition, choose the host port for the next HBA and click **Add**, and then click **Close**.

**Recommendation:** Before closing the window, record the name of each host port along with the WWPN of its corresponding HBA, and save the information to a file for future reference.

## Mapping LUNs to a storage partition

This section contains the following procedures:

- “Mapping LUNs to a new partition” on page 98
- “Adding LUNs to an existing partition” on page 98

## Mapping LUNs to a new partition

When mapping LUNs for the first time to a newly-created partition, complete the procedure in this section that is appropriate to your storage subsystem controller firmware type.

- “Controller firmware 06.12.xx.xx”
- “Controller firmware 05.xx.xx.xx”

**Before you begin:** Read “DS4000 Storage Manager performance planning” on page 14 for information about planning the number of LUNs to map to each partition.

**Note:** HP-UX operating systems do not currently support 256 LUNs per partition.

- HP-UX 11.10 supports up to 32 LUNs per partition.
- HP-UX 11.i supports up to 128 LUNs per partition.
- HP-UX 11v2 supports up to 128 LUNs per partition.

**Controller firmware 06.12.xx.xx:** When mapping LUNs to a newly created partition for the first time, complete the following steps.

**Before you begin:** Read “DS4000 Storage Manager performance planning” on page 14 for information about planning the number of LUNs to map to each partition.

**Important::** If your subsystem is running controller firmware 06.12.xx.xx or higher, you can use the Storage Partitioning wizard feature of the Storage Manager task assistant, instead of this procedure, to map LUNs to a new storage partition.

1. Select the Mappings view of the Subsystem Management window.
2. In the Topology section, right-click the host on which you want to map LUNs, and select **Define Storage Partitioning**. The Define Storage Partitioning window opens.
3. In the Define Storage Partitioning window, select **Host**, then click **Next**.
4. Select the logical drive by name, on the right side of the window.
5. Accept the default LUN ID, or change it, then click **Add**.
6. Repeat step 5 for each LUN that you want to map to the partition.

**Controller firmware 05.xx.xx.xx:** Complete the following steps to map LUNs to a new partition:

1. In the Topology section of the Mappings view of the Subsystem Management window, right-click the host on which you want to map LUNs, and select **Define Storage Partitioning**. The Define Storage Partitioning window opens.
2. In the Define Storage Partitioning window, select **Host**, then click **Next**.
3. Select the logical drive by name, on the right side of the window.
4. Accept the default LUN ID, or change it, then click **Add**.
5. Repeat step 4 for each LUN that you want to map to the partition.

## Adding LUNs to an existing partition

When adding LUNs to an existing partition, complete the following steps to map the new LUNs to the partition.

**Before you begin:** Read “DS4000 Storage Manager performance planning” on page 14 for information about planning the number of LUNs to map to each partition.

1. Select the Mappings view of the Subsystem Management window.
2. In the Topology section, right-click the host on which you want to map LUNs, and select **Define Additional Mappings**. The Define Additional Mapping window opens.
3. In the Define Additional Mapping window, select the following options, and then click **Add**:
  - Host group or host
  - Logical unit number (LUN)(0-255)
  - Logical drive

Repeat these steps for each LUN that you want to add to the partition.

---

## Creating direct-attached and SAN-attached configurations

DS4000 Storage Manager supports IBM DS4000 Storage Subsystems in direct-attached HP-UX configurations or in a SAN environment through switches in HP-UX configurations.

### Creating a direct-attached configuration

To create a direct-attached configuration, you must ensure that:

- One or two HP-UX servers can be connected to DS4000 storage subsystems.
- Two server DS4400 or DS4500 configurations require four host-side minihubs, each with exactly one fibre channel connection from each HBA to a minihub.

**Note:** DS4100, DS4200, DS4300, DS4700, and DS4800 storage subsystems do not have minihubs.

- There are two or four HBAs (HP A6795A or HP A5158A) per DS4000 storage subsystem. Each pair must be configured to one DS4000 partition.
- No external hubs are being used.

Complete the following steps to set up a direct-attached configuration:

1. Connect the HBAs to each controller or minihub port of the DS4000 storage subsystem.
2. Configure and verify the configuration.

### Creating a SAN-attached configuration

To create a SAN-attached configuration, you must ensure that:

- Multiple fibre channel HBAs within the same server must not be able to discover the same DS4000 controller port.
- The IBM Fibre Channel HBAs are isolated from each other if they are connected to the same switch that is connected to the same DS4000 controller port.
- Each fibre channel HBA and controller port must be in its own fabric zone, if they are connecting through a single fibre channel switch, such as a 2109-F16.

Multiple DS4000 devices can be configured to the same set of fibre channel HBAs through a fibre channel switch.

Complete the following steps to set up a SAN-attached configuration:

**Note:** For more information about zoning and enabling zones, see Appendix F, “Connecting HBAs in a FC switch environment,” on page 245.

1. Connect the HBAs to the switch or switches.
2. Connect the DS4000 storage subsystems to the switch or switches.
3. Set the required zones on the fibre channel switch or switches, if applicable.
4. Configure and verify the configuration.

---

## Enabling multipath I/O with PV-links

If the HP-UX system is attached with two host bus adapters to the DS4000 storage subsystem, you can establish redundant access to storage by using physical volume links (PV-links), a feature of the HP-UX operating system. PV-links achieve access redundancy by using devices with both primary and secondary paths to the same device.

### Important:

- There are two methods for establishing redundant access to storage using PV-links:
  - If you have DS4000 controller firmware version 06.1.xx.xx or 05.xx.xx.xx installed, use method 1.
  - If you have DS4000 controller firmware version 04.xx.xx.xx installed, use method 2.
- For both methods, you must have SMutil installed on the host.

## Using PV-links: Method 1

If you have DS4000 controller firmware version 06.1.xx.xx or higher, or 05.xx.xx.xx installed, use the following procedure to enable multipath I/O by using PV-links:

1. Run the **hot\_add** command from HP-UX at the shell prompt. This command updates any new devices that are created or added. A dump is generated. When the **hot\_add** command runs, each new logical drive that is created in the Subsystem Management window represents a disk device to the operating system.

```
#hot_add
```

2. Run the **SMdevices** command. The system provides a dump similar to the example in Figure 20 on page 101. Notice that every logical drive and logical drive access unit has been assigned a logical unit number (LUN). Each logical drive has two paths. Each DS4000 controller has one logical drive access. For example, a subsystem that contains two DS4000 controllers has two logical drive accesses.

```
#SMdevices
```

```

/dev/rdisk/c166t0d0 [Storage Subsystem DS4000, Logical Drive Accounting, LUN 0,
Logical Drive WWN <600a0b80000f56d00000001e3eaead2b>,
Preferred Path (Controller-B): In Use]
/dev/rdisk/c166t0d1 [Storage Subsystem DS4000, Logical Drive HR, LUN 1,
Logical Drive WWN <600a0b80000f5d6c000000273eaeae30>,
Alternate Path (Controller-B): Not In Use]
/dev/rdisk/c166t0d2 [Storage Subsystem DS4000, Logical Drive Finance,
LUN 2, Logical Drive WWN <600a0b80000f5d6c000000253eaeadf8>,
Alternate Path (Controller-B): Not In Use]
/dev/rdisk/c166t0d3 [Storage Subsystem DS4000, Logical Drive Purchasing,
LUN 3, Logical Drive WWN <600a0b80000f5d6c000000243eaeadbe>,
Alternate Path (Controller-B): Not In Use]
/dev/rdisk/c166t0d4 [Storage Subsystem DS4000, Logical Drive Development,
LUN 4, Logical Drive WWN <600a0b80000f56d00000001d3eaeacef>,
Preferred Path (Controller-B): In Use]
/dev/rdisk/c166t3d7 [Storage Subsystem DS4000, Logical Drive Access, LUN 31,
Logical Drive WWN <600a0b80000f56d00000001b00000000>]

/dev/rdisk/c172t0d0 [Storage Subsystem DS4000, Logical Drive Accounting, LUN 0,
Logical Drive WWN <600a0b80000f56d00000001e3eaead2b>,
Alternate Path (Controller-A): Not In Use]
/dev/rdisk/c172t0d1 [Storage Subsystem DS4000, logical Drive HR, LUN 1,
Logical Drive WWN <600a0b80000f5d6c000000273eaeae30>,
Preferred Path (Controller-A): In Use]
/dev/rdisk/c172t0d2 [Storage Subsystem DS4000, Logical Drive Finance, LUN 2,
Logical Drive WWN <600a0b80000f5d6c000000253eaeadf8>,
Preferred Path (Controller-A): In Use]
/dev/rdisk/c172t0d3 [Storage Subsystem DS4000, Logical Drive Purchasing, LUN 3,
Logical Drive WWN <600a0b80000f5d6c000000243eaeadbe>,
Preferred Path (Controller-A): In Use]
/dev/rdisk/c172t0d4 [Storage Subsystem DS4000, Logical Drive Development, LUN 4,
Logical Drive WWN <600a0b80000f56d00000001d3eaeacef>,
Alternate Path (Controller-A): Not In Use]
/dev/rdisk/c172t3d7 [Storage Subsystem DS4000, Logical Drive Access, LUN 31,
Logical Drive WWN <600a0b80000f5d6c0000002200000000>]

```

Figure 20. Sample **SMdevices** command output (method 1)

**Note:** If you do not see the logical drives and logical drive accesses after running the **hot\_add** and **SMdevices** commands, restart the HP-UX host by running the **reboot** command.

```
#reboot
```

- Determine the preferred and alternate path for each logical drive by examining the output from the **SMdevices** command, as shown in the example in Figure 20. Notice that each device is listed twice; one instance is the preferred path and one instance is the alternate path.

#### Preferred path

In the sample output that is shown in Figure 20, the preferred path is **/dev/rdsk/c166t0d0**:

```

/dev/rdsk/c166t0d0 [Storage Subsystem DS4000, Logical Drive
Accounting, LUN 0, Logical Drive WWN <600a0b80000f56d00000001e3eaead2b>,
Preferred Path (Controller-B): In Use]

```

#### Alternate path

In the sample output that is shown in Figure 20, the alternate path is **/dev/rdsk/c172t0d0**:

```
/dev/rdisk/c172t0d0 [Storage Subsystem DS4000, Logical Drive
Accounting, LUN 0, Logical Drive WWN <600a0b80000f56d00000001e3eaead2b>,
Alternate Path (Controller-A): NotIn Use]
```

## Using PV-links: Method 2

If you have DS4000 controller firmware version 4.xx.xx.xx installed, use the following procedures to enable multipath I/O by using PV-links:

- Determine the preferred and alternate paths
- Create the logical drives and logical drive groups

### Determining preferred and alternate paths

Complete the following steps to determine the preferred and alternate paths.

1. Run the **hot\_add** command from HP-UX at the shell prompt. This command updates any new devices that are created or added. A dump is generated. When the **hot\_add** command runs, each new logical drive that is created in the Subsystem Management window represents a disk device to the operating system.

```
#hot_add
```

2. Run the **SMdevices** command. The system provides a dump similar to the example in Figure 21. Notice that every logical drive and logical drive access unit has been assigned a logical unit number (LUN). Each logical drive has two paths. Each DS4000 controller has one logical drive access. For example, a subsystem that contains two DS4000 controllers has two logical drive accesses.

```
#SMdevices
```

```
/dev/rdisk/c166t0d0 [Storage Subsystem DS4000, Logical Drive Accounting, LUN 0,
Logical Drive WWN <600a0b80000f56d00000001e3eaead2b>]
/dev/rdisk/c166t0d1 [Storage Subsystem DS4000, Logical Drive HR, LUN 1,
Logical Drive WWN <600a0b80000f5d6c000000273eaeae30>]
/dev/rdisk/c166t0d2 [Storage Subsystem DS4000, Logical Drive Finance, LUN 2,
Logical Drive WWN <600a0b80000f5d6c000000253eaeadf8>]
/dev/rdisk/c166t0d3 [Storage Subsystem DS4000, Logical Drive Purchasing, LUN 3,
Logical Drive WWN <600a0b80000f5d6c000000243eaeadbe>]
/dev/rdisk/c166t0d4 [Storage Subsystem DS4000, Logical Drive Development, LUN 4,
Logical Drive WWN <600a0b80000f56d00000001d3eaeacef>]
/dev/rdisk/c166t3d7 [Storage Subsystem DS4000, Logical Drive Access, LUN 31,
Logical Drive WWN <600a0b80000f56d00000001b00000000>]

/dev/rdisk/c172t0d0 [Storage Subsystem DS4000, Logical Drive Accounting, LUN 0,
Logical Drive WWN <600a0b80000f56d00000001e3eaead2b>]
/dev/rdisk/c172t0d1 [Storage Subsystem DS4000, logical Drive HR, LUN 1,
Logical Drive WWN <600a0b80000f5d6c000000273eaeae30>]
/dev/rdisk/c172t0d2 [Storage Subsystem DS4000, Logical Drive Finance, LUN 2,
Logical Drive WWN <600a0b80000f5d6c000000253eaeadf8>]
/dev/rdisk/c172t0d3 [Storage Subsystem DS4000, Logical Drive Purchasing, LUN 3,
Logical Drive WWN <600a0b80000f5d6c000000243eaeadbe>]
/dev/rdisk/c172t0d4 [Storage Subsystem DS4000, Logical Drive Development, LUN 4,
Logical Drive WWN <600a0b80000f56d00000001d3eaeacef>]
/dev/rdisk/c172t3d7 [Storage Subsystem DS4000, Logical Drive Access, LUN 31,
Logical Drive WWN <600a0b80000f5d6c0000002200000000>]
```

Figure 21. Sample SMdevices command output (method 2)



**Note:** If you do not see the logical drives and logical drive accesses after running the **hot\_add** and **SMdevices** commands, restart the HP-UX host by running the **reboot** command.

```
#reboot
```

- Determine the preferred and alternate path for each logical drive by examining the output from the **SMdevices** command, as shown in the example in Figure 21 on page 102.

Notice that each device is listed twice; one instance is the preferred path and one instance is the alternate path. Also, notice that each device has a worldwide name (WWN). Part of the WWN of each logical drive is unique for each controller in the DS4000 storage subsystem. If you examine the WWNs for the logical drive access in Figure 21 on page 102, you notice that they differ in only five digits, f56d0 and f5d6c.

The devices in Figure 21 on page 102 are viewed through the controllers c166 and c172. To determine the preferred path of a specific logical drive seen by the operating system perform the following steps:

- Find the WWN for each logical drive access. In this case, Logical Drive Access 1 is associated with **c166** and has the WWN of **f56d0**.

```
/dev/rdisk/c166t3d7 [Storage Subsystem DS4000, Logical Drive Access, LUN 31, Logical Drive WWN <600a0b80000f56d0000001b00000000>]
```

Logical Drive Access 2 is associated with **c172** and has the WWN of **f5d6c**:

```
/dev/rdisk/c172t3d7 [Storage Subsystem DS4000, Logical Drive Access, LUN 31, Logical Drive WWN <600a0b80000f5d6c0000002200000000>]
```

- Identify the preferred device path name for the attached storage device by matching the logical drive WWN to a logical drive access WWN. In this case, the WWN for **LUN 0** is associated with controller **c166** and **c172**. Therefore, the preferred path for **LUN 0** is **/dev/rdisk/c166t0d0**, which is controller **c166**:

```
/dev/rdisk/c166t0d0 [Storage Subsystem DS4000, Logical Drive Accounting, LUN 0, Logical Drive g<600a0b80000f56d00000001e3eaead2b>]
```

The alternate path is **/dev/rdisk/c172t0d0**, which is controller **c172**:

```
/dev/rdisk/c172t0d0 [Storage Subsystem DS4000, Logical Drive Accounting, LUN 0, Logical Drive WWN <600a0b80000f56d00000001e3eaead2b>]
```

- To keep a record for future reference, enter this path information for LUN 0 into a matrix (similar to the one in Table 15).

Table 15. Sample record of logical drive preferred and alternate paths

LUN	Logical drive name	Preferred path	Alternate path
0	Accounting	/dev/rdisk/c166t0d0	/dev/rdisk/c172t0d0
1	HR	/dev/rdisk/c172t0d1	/dev/rdisk/c166t0d1
2	Finance	dev/rdisk/c172t0d2	/dev/rdisk/c166t0d2
3	Purchasing	/dev/rdisk/c172t0d3	/dev/rdisk/c166t0d3
4	Development	/dev/rdisk/c166t0d4	/dev/rdisk/c172t0d4

- d. Repeat step 3a on page 103 through step 3c on page 103 for each logical drive that is seen by the operating system.

Continue to the next procedure.

### Creating volumes and volume groups

After you have determined the preferred and alternate paths, and have recorded them in a matrix for future reference, perform the following steps to create volumes and volume groups.

**Important:** Do not use SAM for DS4000 storage configuration. If you do, you might get unexpected results.

**Note:** The steps in this procedure refer to LUN 0 in Table 15 on page 103.

1. Create a physical volume and define the primary paths for the attached storage devices. The primary path will be the preferred path. Type the following command at the shell prompt:

```
#pvcreate /dev/rdisk/c166t0d0
```

The system confirms the creation of the new physical volume.

2. Create volume groups.

**Note:** For more information on how to create volume groups, refer to HP-UX documentation or to man pages.

- a. Make a directory for volume group by typing the following commands. This directory must reside in the /dev directory.

```
#cd /dev  
#mkdir /vg1
```

- b. Create the group special file in the /dev directory for the volume group by typing the following command:

```
#mknod /dev/vg1/group c 64 0x010000
```

- c. Create a volume group and define physical volume names (primary link) for the attached storage device by typing the following command:

```
#vgcreate /dev/vg1/ /dev/dsk/c166t0d0
```

- d. Define the secondary path name (alternate path) for the attached-storage device by typing the following command:

```
#vgextend vg1 /dev/dsk/c172t0d0
```

**Note:** You can also use the **vgextend** command to add additional storage devices to an existing volume group. Add the primary path first, then add the alternate path, as shown in the following example:

- 1) Add the primary path for LUN1.

```
#vgextend vg1 /dev/dsk/c172t0d1
```

2) Add the secondary path for LUN1.

```
#vgextend vg1 /dev/dsk/c166t0d1
```

3. Create logical volumes. For more information, refer to HP-UX documentation.
4. Create file systems for the logical volumes.
5. Repeat step 1 on page 104 through step 4 to create additional volume groups. For more information, refer to HP-UX documentation.
6. Verify the primary (preferred) and secondary (alternate) paths for each device by typing the following command:

```
#vgdisplay -v vgname
```

where *vgname* is the volume group name.

---

## Redistributing logical drives in case of failure

Auto Volume Transfer (AVT) is enabled, by default, on HP-UX hosts. If a failure occurs that initiates a controller failover, AVT redirects I/O to the available controller. AVT does not require manual redistribution.

**Important:** If a failure occurs in a heterogeneous host environment, the HP-UX host with AVT enabled will automatically redistribute its LUNs when the path becomes available. However, you will need to manually redistribute logical drives on any host that does not have AVT enabled. Failure to do so will leave the subsystem in a *Needs Attention* state, because hosts that do not support AVT or have AVT disabled will not automatically redirect I/O to the preferred controller. In this case, Storage Manager Recovery Guru will indicate which host platform is associated with the LUN that is in a failover state.



---

## Chapter 4. Installing and configuring storage management software on Solaris host systems

This chapter provides the following information for Solaris operating systems:

- “Installing DS4000 Storage Manager” on page 108
- “Configuring storage subsystems” on page 115
- “Creating storage partitions” on page 119
- “Creating direct-attached and SAN-attached configurations” on page 123
- “Configuring the host bus adapter cards” on page 123
- “Installing a failover driver on Solaris” on page 134
- “Verifying external storage” on page 148
- “Redistributing logical drives in case of failure” on page 149

---

### Solaris system requirements

This section lists the minimum hardware and software requirements for a Solaris host in a DS4000 storage subsystem that is managed by DS4000 Storage Manager 10.10.

#### Hardware requirements

The Solaris system must be a SPARC S20 processor with:

- 1 GB system memory
- CD-ROM drive
- Mouse or similar pointing device
- Ethernet network interface card
- 2 GB available on /opt and root (or root-equivalent) privileges for installing RDAC

#### Software requirements

Use the following software:

##### Operating system

Ensure that the Solaris host is running one of the following operating systems with the appropriate patches:

##### Solaris 8

Maintenance update 7, including the latest patch

##### Solaris 9

Maintenance update 4, including the latest patch

##### Solaris 10

Including the latest patch

##### Notes:

1. See your Solaris operating system documentation or contact your operating system supplier to ensure that you have the correct patches. In addition, review the device driver readme files for other Solaris patches that you might need.
2. Updated DS4000 Storage Manager readme files contain important configuration information that supersedes this document. To access the most recent DS4000 Storage Manager readme file for Solaris, see “Finding the Storage Manager readme files online” on page 24.
3. Solaris 10 does not support the RDAC failover driver or JNI host bus adapters.

---

## Installing DS4000 Storage Manager

The DS4000 Storage Manager software includes the following software packages:

### **SMruntime (required)**

SMruntime is a Java compiler for the DS4000 Storage Manager software packages. SMruntime must be installed before the other packages are installed.

### **SMesm (required with SMclient)**

SMesm is the mechanism for delivering ESM firmware, which contains a defined set of ESM firmware files that are used by the auto-sync mechanism.

### **SMclient (optional)**

SMclient is Storage Manager's graphical user interface (GUI), which you use to manage your storage subsystems. If you are not using your Solaris host as a storage management station (for example, if you are using a Windows management station with SMclient installed), then you do not need to install SMclient on your Solaris host.

### **SMagent (optional)**

SMagent contains host-agent software, which you can use to manage your subsystems if you are using an in-band management configuration (managing the storage subsystems through the fibre channel I/O path to the host). If you are using an out-of-band management configuration, you do not need to install SMagent.

### **SMutil (required)**

SMutil is a utility that you can use to register and map new logical drives to the operating system. SMutil is required on Solaris host systems.

You can install all of the DS4000 Storage Manager software packages automatically by using the Storage Manager installation wizard, or you can install each package manually. This section contains the following procedures:

- "Installing Storage Manager using the installation wizard"
- "Installing Storage Manager packages manually" on page 109 (original method)

## Installing Storage Manager using the installation wizard

The DS4000 Storage Manager installation wizard can install all of the Storage Manager software packages automatically. If you prefer, you can install just the following **required** packages onto your Solaris host:

- SMruntime
- SMutil

To choose the packages that you want to install, select Custom Installation during the installation procedure, as described in "Steps for installing Storage Manager using the installation wizard" on page 109.

### **Installation wizard requirements**

To use the installation wizard, you must meet the following requirements:

- You are installing DS4000 Storage Manager 10.10.
- Your Solaris host has a graphics adapter card installed.

If you are installing Storage Manager 10.10 on Solaris, and your system does not meet the requirements for using the wizard, does not have a graphics card installed, or if for any reason you do not want to use the wizard to install the

software, you can perform the installation without a GUI by typing the `sh <installer-package-name.bin> -i console` command in the command line interface. You can also skip this section and install the stand-alone host software packages using the procedures described in “Installing Storage Manager packages manually.” All the packages are included with the installation CD.

**Note:** Do not install the software packages in the same server by using both the installation wizard and the manual installation method.

### Steps for installing Storage Manager using the installation wizard

Complete the following steps to install the DS4000 Storage Manager software using the installation wizard. Adjust the steps as necessary for your specific installation.

1. Download the following file from the DS4000 Storage Manager CD, or from the DS4000 support Web site, to a directory on your system:  
SMIA-SOL-10.10.xx.xx.bin
2. Open the file on your system. The Storage Manager Installation wizard's Introduction window opens.
3. Follow the instructions in each window of the wizard. When you select the installation type, you can choose one of the following options:
  - Typical (Full) Installation—Installs all Storage Manager software packages
  - Management Station—Installs SMruntime and SMclient
  - Host—Installs SMruntime, SMagent and SMutil
  - Custom—Allows you to select which packages you want to install

**Important:** If you plan to use VERITAS DMP or Solaris MPxIO as a failover driver instead of RDAC, you must select **Custom Installation** as the installation type. Then, when you select the components you want to install, make sure that RDAC is *not* selected. This is a *requirement* for Solaris 10, which does not support RDAC.

4. Restart the system.

**Result:** The DS4000 Storage Manager software is installed on your system.

## Installing Storage Manager packages manually

If you are installing Storage Manager 10.10, use the following procedures in the order listed to install the DS4000 Storage Manager software on a Solaris storage management station.

1. “Installing the client software” on page 110
2. “Installing the host software” on page 113

**Note:** If you are installing Storage Manager 9.12 or higher, do not install the software manually. Instead, use the installation procedure that is described in “Installing Storage Manager using the installation wizard” on page 108.

### Prerequisites

Before installing the client software, ensure that the following conditions are met:

- This is the SUN SPARCstation workstation that you have identified as the storage management station.
- This machine is running Solaris 8, 9, or 10, and meets the minimum hardware and software requirements described in “Solaris system requirements” on page 107.
- Neither DS4000 SMruntime software nor DS4000 SMclient software is installed on the host, and you are ready to install them on this machine.

- The DS4000 Storage Manager installation files are available in a directory on the system.

## Installing the client software

For the specific installation order, see Table 3 on page 5.

**Note:** The SMclient is dependent on SMruntime, which is a Java compiler for the SMclient. SMruntime must be installed first.

**Steps for installing SMruntime software (required):** Modify these commands as needed for your installation. No restart is required during the client installation process.

**Before you begin:** Visit the Web site that is listed in “Finding the Storage Manager readme files online” on page 24 to ensure you have the most recent version of the software.

1. Insert the Solaris installation CD in the CD-ROM drive.
2. Start the installation process by typing the following command:

```
pkgadd -d path/filename.pkg
```

where *path/filename* is the directory path and name of the package that you want to install. Information about packages that can be installed in the specified directory is displayed on the command line. The following is an example of what you might see displayed.

```
The following packages are available:
1 SMruntime
IBM DS4000 Storage Manager 10 Runtime (sparc)
version number Select package(s) you wish to process (or 'all'
to process all Packages). (default:all) [?,?,q]:
```

3. Press **Enter** to select the default (all). The installation process begins. The following prompt is displayed:

```
This package contains scripts which will be executed with super-user
Permission during the process of installing this package.
Do you want to continue with the installation of <SMruntime>
[y, n, ?]
```

4. Type *y* and press **Enter**. The installation process continues. When the SMruntime software has been successfully installed, the following message is displayed:

```
Installation of <SMruntime> was successful.
```

5. Type the following command to verify that the installation is successful:

```
# pkginfo -l SMruntime
```

The installation is successful if the following message displays:

```
INSTDATE: date/time
STATUS: completely installed
```

where *date/time* is today's installation date and time.

**Steps for installing SMesm software (required if installing SMclient):** If you are using your Solaris host as a storage management station, then you must install



SMesm on the host. If you are using a different computer as your storage management station, install SMesm on that computer.

Modify these commands as needed for your installation. No restart is required during the esm installation process.

1. Insert the Solaris installation CD in the CD-ROM drive.
2. Start the installation process by typing the following command:

```
# pkgadd -d path/filename.pkg
```

where *path/filename* is the directory path and name of the package that you want to install.

Information about packages that can be installed in the specified directory is displayed on the command line. The following is an example of what you might see displayed.

```
The following packages are available:
```

```
1 SMesm                IBM DS4000 Storage Manager 10 Esm
                        (sparc) version number
```

```
Select package(s) you wish to process (or 'all' to process all
packages). (default:all) [?,??,q]:
```

3. Press **Enter** to select the default (all).

The installation process begins. The following prompt is displayed:

```
This package contains scripts which will be executed with super-user
permission during the process of installing this package.
```

```
Do you want to continue with the installation of <SMesm>
```

```
[y, n, ?]
```

4. Type **y** and press **Enter**.

The installation process continues. When the SMesm software has been successfully installed, the following message is displayed:

```
Installation of <SMesm> was successful.
```

5. Type the following command to verify that the installation is successful:

```
# pkginfo -l SMesm
```

The installation is successful if the following message displays:

```
INSTDATE: date/time
STATUS: completely installed
```

where *date/time* is today's installation date and time.

**Result:** The esm software installation on this Solaris storage management station is complete. Remove the installation CD from the CD-ROM drive.

**Note:** To ensure redundancy in a cluster environment, you must install the esm software on at least one additional storage management station or cluster server. To install the esm software on additional storage management

stations, repeat the installation procedure. Use the corresponding installation profile for each storage management station as a guide.

To find out which cluster services are currently supported with DS4000 on Solaris operating systems, see the latest DS4000 interoperability matrix at the following Web page:

[www-1.ibm.com/servers/storage/disk/ds4000/interop-matrix.html](http://www-1.ibm.com/servers/storage/disk/ds4000/interop-matrix.html)

**Steps for installing SMclient software (optional):** If you are using your Solaris host as a storage management station, then you must install SMclient on the host. If you are using a different computer as your storage management station, install SMclient on that computer.

Modify these commands as needed for your installation. No restart is required during the client installation process.

1. Insert the Solaris installation CD in the CD-ROM drive.
2. Start the installation process by typing the following command:

```
# pkgadd -d path/filename.pkg
```

where *path/filename* is the directory path and name of the package that you want to install.

Information about packages that can be installed in the specified directory is displayed on the command line. The following is an example of what you might see displayed.

```
The following packages are available:
1 SMclient                      IBM DS4000 Storage Manager 10 Client
                                (sparc) version number
Select package(s) you wish to process (or 'all' to process all
packages). (default:all) [?,??,q]:
```

3. Press **Enter** to select the default (all).

The installation process begins. The following prompt is displayed:

```
This package contains scripts which will be executed with super-user
permission during the process of installing this package.
Do you want to continue with the installation of <SMclient>
[y, n, ?]
```

4. Type **y** and press **Enter**.

The installation process continues. When the SMclient software has been successfully installed, the following message is displayed:

```
Installation of <SMclient> was successful.
```

5. Type the following command to verify that the installation is successful:

```
# pkginfo -l SMclient
```

The installation is successful if the following message displays:

```
INSTDATE: date/time
STATUS: completely installed
```

where *date/time* is today's installation date and time.

**Result:** The client software installation on this Solaris storage management station is complete. Remove the installation CD from the CD-ROM drive.

**Note:** To ensure redundancy in a cluster environment, you must install the client software on at least one additional storage management station or cluster server. To install the client software on additional storage management stations, repeat the installation procedure. Use the corresponding installation profile for each storage management station as a guide.

To find out which cluster services are currently supported with DS4000 on Solaris operating systems, see the latest DS4000 interoperability matrix at the following Web page:

[www-1.ibm.com/servers/storage/disk/ds4000/interop-matrix.html](http://www-1.ibm.com/servers/storage/disk/ds4000/interop-matrix.html)

### Installing the host software

If you are installing the optional SMagent, install the host software in the following order. If you are not installing SMagent, then SMutil is the only DS4000 Storage Manager host software that you need to install.

- DS4000 SMagent software (optional—for in-band management only)
- DS4000 SMutil software (required)

**Prerequisites:** Before installing the host software, ensure that the following conditions are met:

- This is the Sun SPARCstation workstation that you have identified as the storage management station.
- This machine is running Solaris 8, 9 or 10, and meets the minimum hardware and software requirements described in Appendix B, “JNI and QLogic host bus adapter settings,” on page 223.
- The SMagent and SMutil software packages are not installed, and you are ready to install them on this machine.
- RDAC or DMP is not installed.

**Note:** SMagent is not supported with DS4000 controller firmware version 05.42.xx.xx.

**Steps for installing SMagent software (optional):** SMagent is required for in-band management only. It is not required for out-of-band management.

Complete the following steps to install SMagent:

1. Type the following command to start installing the SMagent package:

```
pkgadd -d path/filename.pkg
```

where *path/filename* is the directory path and name of the package that you want to install.

The installation process begins.

Information about packages that can be installed in the specified directory is displayed on the command line. The following is an example of what you might see displayed.

```
The following packages are available:

1 SMagent                               IBM DS4000 Storage Manager 10 Agent
                                         (sparc) version number

Select package(s) you wish to process (or 'all' to process all
packages). (default:all) [?,??,q]:
```

2. Press **Enter** to select the default (all).

The installation process begins. The following prompt is displayed:

```
This package contains scripts which will be executed with super-user
Permission during the process of installing this package.
Do you want to continue with the installation of <SMagent>
[y n, ?]
```

3. Type **y** and press **Enter**.

The installation process continues. When the SMagent software has been successfully installed, the following message is displayed:

```
Installation of <SMagent> was successful.
```

4. Type the following command to verify that the installation is successful:

```
# pkginfo -l SMagent
```

The installation is successful if the following message displays:

```
INSTDATE: date/time
STATUS: completely installed
```

where *date/time* is today's installation date and time.

5. Remove the installation CD from the CD-ROM drive.

**Steps for installing SMutil software (required):** Complete the following steps to install SMutil:

1. Type the following command to start installing the SMutil package:

```
pkgadd -d path/filename.pkg
```

where *path/filename* is the directory path and name of the package that you want to install.

The installation process begins.

When the SMutil has been successfully installed, the following message is displayed:

```
Installation of <SMutil> was successful.
```

2. Type the following command to verify that the installation is successful:

```
# pkginfo -l SMutil
```

The installation is successful if the following message displays:

```
INSTDATE: date/time
STATUS: completely installed
```

where *date/time* is today's installation date and time.

**Result:** You have finished installing the host software on this Solaris host.

---

## Configuring storage subsystems

To configure DS4000 Storage Manager for a Solaris system, complete the following procedures in the order that they are described in this section:

- Add storage subsystems to DS4000 SMclient
- Update NVSRAM and DS4000 firmware (if necessary)

**Before you begin:** Read the following information:

- All DS4000 storage subsystems have an access logical drive set to LUN 31.

**Note:** Do not delete the access LUN or the access logical drive.

- If you have purchased a Storage Partitioning premium feature, ensure that the feature is enabled. See “Enabling premium features” on page 18 for more information.
- Versions of controller firmware and NVSRAM that are provided with this product might be later releases than those described in this document. To ensure that you have the latest versions of the firmware and the NVSRAM, read the Storage Manager readme file for Solaris that is provided with the product. See “Finding the Storage Manager readme files online” on page 24.

**Note:** If you do not have the latest versions of controller firmware and NVSRAM, download them and complete the procedure described in “Upgrading controller firmware and NVSRAM.” If the version numbers are current, you can skip that procedure.

## Adding storage subsystems to SMclient

Complete the following steps to specify the IP addresses of the controllers:

1. In the Enterprise Management window, click **Edit → Add Storage Subsystem**.
2. In the Add Storage Subsystem window, type the IP addresses of each controller in the storage subsystem, and click **Add**. The name of the storage subsystem displays in the Enterprise Management window.

**Important:** Failure to add both controllers results in a partially-managed system.

## Upgrading controller firmware and NVSRAM

The procedures in this section describe how to download and install DS4000 controller firmware and NVSRAM.

**Note:** If you are upgrading a DS4800, DS4700, or a DS4200 storage subsystem to controller firmware version 07.10.xx.xx, see Appendix D, “Using the IBM System Storage DS4000 Controller Firmware Upgrade Tool,” on page 235.

### Overview

Read the information in the following sections before you begin the download procedures:

- “Using concurrent download” on page 116
- “Using traditional or staged download” on page 116

**Using concurrent download:** Depending on your system's current firmware version, you might be able to use *concurrent download*. Concurrent download is a method of downloading firmware to the controllers that does not require you to stop I/O to the controllers during the process.

**Note:** Some controller firmware versions might not support concurrent download. See the latest Storage Manager readme file for Solaris to find out which firmware versions support concurrent download.

**Using traditional or staged download:** There are two methods for downloading the firmware to the controllers:

- "Traditional download"
- "Staged download"

*Traditional download:* The traditional download process takes significantly longer and must be done in one phase, rather than in two phases as with the staged controller firmware download. Therefore the preferred method of controller firmware download is the staged controller firmware download.

*Staged download:* With staged firmware download, the download process occurs in two distinct phases: firmware transfer and firmware activation. You can perform the time-consuming task of loading the firmware online so that it is functionally transparent to the application. You can then defer the activation of the loaded firmware to a convenient time.

Some reasons for activating firmware files at a later time include the following:

- **Time of day**—Activating can take a long time, so you might want to wait until I/O loads are lighter because the controllers will go offline briefly to activate the new firmware.
- **Type of package**—You might want to test the new firmware package on one storage subsystem before activating it on other storage subsystems.
- **Multiple controllers**—You can download controller firmware from the storage management software to all storage subsystem controllers for later activation.

**Notes:**

1. You cannot use staged download to upgrade DS4000 controller firmware version 05.xx.xx.xx to version 6.2x.xx.xx or version 06.xx to version 07.10. You can only use staged download if the DS4000 controller firmware version is already 6.1x.xx.xx, and you are downloading another version of 6.1x.xx.xx firmware or higher.
2. Staged controller firmware download is not supported on DS4400 storage subsystems.

**Important:** Do not perform other storage management tasks, such as creating or deleting logical drives, reconstructing arrays, and so on, while downloading the DS4000 storage subsystem controller firmware. It is recommended that you close all storage management sessions (except for the session that you use to upgrade the firmware) to the DS4000 storage subsystem that you plan to update. Also, the subsystem must be in Optimal state prior to loading firmware or NVSRAM.

### **Preparing for firmware or NVSRAM download**

To prepare for download, review and complete all of the steps in this section before you start the download procedures.

**Check current versions of controller firmware and NVSRAM:** Versions of controller firmware and NVSRAM that are provided with this product might be later releases than those described in this document.

To check the controller firmware and NVSRAM versions that are currently installed on your system, complete the following steps:

1. In the Subsystem Management window, click **Storage Subsystem → View Profile**. The Storage Subsystem Profile window displays.
2. In the Storage Subsystem Profile window, click the Controllers tab to view the current versions of controller firmware and NVSRAM.
3. Click **Close** to close the Storage Subsystem Profile window.
4. To find whether the versions of controller firmware and NVSRAM that are currently on your storage subsystem are the latest versions, read the Storage Manager readme file for Solaris. See “Finding the Storage Manager readme files online” on page 24.
5. If you find that you do not have the latest versions of the firmware and NVSRAM, download the correct versions from this Web site to a directory on your system, then follow the preparation and upgrade procedures that are described in this section.

**Save the storage subsystem configuration:** Saving the storage subsystem configuration to a script file is necessary in order to restore the configuration in the event of a catastrophic failure.

**Attention:** Do not use this option if the storage subsystem is undergoing an operation that changes any configuration settings. (If any logical drive listed in the Logical View of the Subsystem Management window has a clock icon, then a configuration change is occurring, and you must wait to save the configuration.)

You can also save the storage subsystem profile, by selecting **Storage Subsystem → View Profile** in the Subsystem Management window, and clicking **Save As**. Then, in the Save Profile window, select the sections of the profile that you want to save, specify a name and location for the text file, and click **Save**.

Save the storage subsystem configuration by completing the following steps:

1. In the Subsystem Management window, click **Storage Subsystem → Configuration → Save**. The Save Configuration window displays.
2. In the Save Configuration window, select the elements of the configuration that you want to save, and click **Yes**. A save dialog displays.
3. In the save dialog, specify a name for the script file and select its location.

**Notes:**

- a. The .cfg extension is used by default for the script file if you do not specify a file extension.
  - b. Do not store your DS4000 Storage Subsystem configuration script file in the same location as the logical drives that are defined on your DS4000 Storage Subsystem. If you do, and the logical drives fail during the subsequent migration, you will lose data.
4. Click **Save**. The Configuration Saved window displays.
  5. Review the information in the Configuration Saved window, then click **OK** to return to the Subsystem Management window.

**Determine whether you need to stop I/O:** You can use concurrent download *only* if you are upgrading from one version of controller firmware to a later release of the same version.

**Example:** For example, if you are upgrading from **06.10.xx.xx** to **6.12.xx.xx**, you can use concurrent download. However, if you are upgrading from **05.xx.xx.xx** to **06.1x.xx.xx**, you *cannot* use concurrent download.

In addition, before you upgrade controller firmware, ensure that concurrent download is supported with your system's current firmware versions, using the information that is listed in Table 16.

**Notes:**

1. Some controller firmware versions might not support concurrent download. See the latest Storage Manager readme file for Solaris to find out which firmware versions support concurrent download.
2. Single-controller (SCU) storage subsystem models do not support concurrent download.

*Table 16. Firmware versions that support concurrent download (Solaris)*

<b>DS4000 storage subsystem:</b>	<b>Controller firmware version:</b>
DS4100	06.10.xx.xx, 06.12.xx.xx
DS4200	06.16.88.xx, 06.23.xx.xx, 06.60.xx.xx, 07.10.xx.xx
DS4300 base and Turbo	06.10.xx.xx, 06.12.xx.xx, 06.19.xx.xx, 06.60.xx.xx
DS4400	06.10.xx.xx, 06.12.xx.xx
DS4500	06.10.xx.xx, 06.12.xx.xx, 06.19.xx.xx, 06.60.xx.xx
DS4700	06.16.xx.xx, 06.23.xx.xx, 06.60.xx.xx, 07.10.xx.xx
DS4800	06.16.xx.xx, 06.23.xx.xx, 06.60.xx.xx, 07.10.xx.xx
All other DS4000 storage subsystems	05.30.xx.xx, 06.10.xx.xx, 06.12.xx.xx

**Steps for upgrading the controller firmware**

Complete the following steps to install a new firmware version on the controllers:

1. Download the correct version of the firmware from the Web site that is listed in "Check current versions of controller firmware and NVSRAM" on page 117. Place the file in a designated directory on the host system.
2. Check your system's current firmware versions to determine whether you need to stop I/O before upgrading the controller firmware, using the information that is listed in Table 16 and in the latest Storage Manager readme file for Solaris.  
**Attention:** If you do not have the latest firmware levels for concurrent download, you *must* stop I/O to the controllers before you upgrade the controller firmware.
3. Ensure that the array is in an Optimal state. If it is not, resolve the issue before continuing to the next step.
4. In the Subsystem Management window, click **Advanced** → **Maintenance** → **Download** → **Controller Firmware**. The Download Firmware window displays.
5. Click **Browse** to select the firmware file that you previously downloaded to a directory on the host.
6. If you want to perform a staged firmware download, select the check box next to "Transfer files but don't activate them (activate later)." If you want to perform a traditional firmware download, do not select the check box, and the firmware will load immediately.



7. Click **OK**. The Confirm Download window displays.
8. Click **Yes** to start the download.
9. Verify that the firmware was successfully installed.
10. After you verify that the firmware was successfully installed, then you can restart I/O to the subsystem.

### Steps for upgrading the NVSRAM

Complete the following steps to install a new version of NVSRAM on the controllers. NVSRAM will be activated immediately.

1. Download the correct NVSRAM version from the Web site that is listed in “Check current versions of controller firmware and NVSRAM” on page 117. Place the file in a designated directory on the host system.
2. Stop I/O.
3. Ensure that the array is in an Optimal state. If it is not, resolve the issue before continuing to the next step.
4. In the Subsystem Management window, click **Advanced** → **Maintenance** → **Download** → **Controller NVSRAM**. The Download NVSRAM window displays.
5. Click **Browse** to select the NVSRAM file that you previously downloaded to a directory on the host.
6. Click **OK**. The Confirm Download window displays.
7. Click **Yes** to start the download.
8. Verify that the NVSRAM was successfully installed.
9. Start I/O.

---

## Creating storage partitions

To create storage partitions, you must complete the following procedures in this section:

- “Steps for defining a Solaris host group” on page 120
- “Steps for defining the host and host port” on page 120
- “Mapping LUNs to a storage partition” on page 121

## Storage partitioning overview

When you begin to create your storage partitions using the procedures in this section, be aware of the following information:

- If your subsystem is running controller firmware 06.1x.xx.xx or higher, the Storage Manager task assistant provides a Storage Partitioning wizard that you can use to define your host and host ports, and map LUNs to the storage partitions. If your subsystem is running controller firmware 05.xx.xx.xx, you cannot use the wizard. Both types of procedures are documented in this section.
- The procedures in this section assume that you have already created a physical connection between the host and the storage subsystem controllers, and that you have also connected and zoned the SAN switch (if any). If you have not completed these connections, please note that Storage Manager will *not* be able to list the WWPNs of the HBAs during these procedures. In this case you will need to type the WWPNs into the appropriate fields during the steps for defining a host and host ports.
- Create the Solaris host group at the storage subsystem level. Do not create host groups at the default group level.

**Exceptions:** If you are running a DS4300 configuration without partitioning enabled, you can use the default host group.

## Steps for defining a Solaris host group

A *host group* is an entity in the Storage Partitioning topology that defines a logical collection of host computers that require shared access to one or more logical drives. You can grant individual hosts in a defined host group access to storage partitions, independently of the host group.

Complete the following steps to define a host group:

1. Click the **Mappings View** tab on the Subsystem Management window.
2. In the Topology section of the Mappings window, highlight the name of the storage subsystem, and click **Mappings** → **Define** → **Host Group**.

**Note:** Make sure that the storage subsystem is highlighted in the left panel of the Subsystem Management window. Do not highlight Undefined Mappings.

3. Type the name of the new host group (for example, Solaris). Click **Add**, and then click **Close**.

## Steps for defining the host and host port

Complete the steps that are appropriate for your storage subsystem controller firmware type.

- “Controller firmware 06.12.xx.xx or higher”
- “Controller firmware 05.xx.xx.xx” on page 121

### Controller firmware 06.12.xx.xx or higher

If your subsystem has controller firmware 06.12.xx.xx or higher installed, complete the following steps to define the host and host ports by using the **Define a host and host ports** wizard:

1. In the Topology section of the Mappings view of the Subsystem Management window, right-click the new host group and select **Define Host**. The **Introduction (Define Host)** window opens.
2. Click **Next**. The **Specify Host Name/HBA Attribute (Define Host)** window opens.
3. Type the host name in the **Specify Host Name/HBA Attribute (Define Host)** window. In the left panel, select the correct WWPN of the HBA host port. Click **Add**.

**Note:** If you there is not yet a physical connection between the host and the DS4000 controllers, as described in the “Storage partitioning overview” on page 119, the WWPNs will not display. In this case, you must type the correct WWPN into the field.

4. You must now provide an alias name for the host port. Click **Edit**, then type an alias name (for example, Port1).
5. On configurations with two or more HBAs, repeat step 3 and step 4 for each host port that you need to define, then proceed to step 6.
6. Click **Next**. The **Specify Host Type** window opens.
7. Select the correct host type, Solaris or Solaris with DMP, from the drop down menu and click **Next**. The **Review** window opens.

**Note:** Failure to change the host type from the default will cause undesired results. If you are using RDAC or MPxIO as your failover driver, select the Solaris host type. If you are using DMP, select Solaris with DMP.

8. Review the information for accuracy, and make any necessary changes. Then click **Next**.

**Recommendation:** Record the name of each host port along with the WWPN of its corresponding HBA, and save the information to a file for future reference.

9. After Storage Manager finishes defining the host and host ports, a dialog window opens. If you need to define another host, select **Define another host**. To finish, click **Exit**. The wizard closes.

### Controller firmware 05.xx.xx.xx

If your subsystem has controller firmware 05.xx.xx.xx installed, complete the following steps to define a host and host ports.

**Note:** IBM recommends upgrading your controllers to the latest controller firmware that is available for your storage subsystem.

1. In the Topology section of the Mappings view of the Subsystem Management window, highlight the new host group and click **Mappings** → **Define** → **Host**.
2. Define the new host. Type the name of the Solaris host to which the storage subsystem is attached.
  - a. Click **Add**, and then click **Close**.
  - b. Highlight the host that you just added, then right-click and select **Define Host Port**.
  - c. Type or select the desired host port for the first HBA, and then change the host type to Solaris or Solaris with DMP. Click **Add**.

**Note:** Failure to change the host type from the default will cause undesired results. If you are using RDAC or MPxIO as your failover driver, select the Solaris host type. If you are using DMP, select Solaris with DMP.

- d. If you are configuring additional HBAs to this partition, choose the host port for the next HBA and click **Add**, and then click **Close**.

**Recommendation:** Before closing the window, record the name of each host port along with the WWPN of its corresponding HBA, and save the information to a file for future reference.

## Mapping LUNs to a storage partition

This section contains the following procedures:

- “Mapping LUNs to a new partition”
- “Adding LUNs to an existing partition” on page 122

### Mapping LUNs to a new partition

When mapping LUNs for the first time to a newly-created partition, complete the procedure in this section that is appropriate to your storage subsystem controller firmware type.

- “Controller firmware 06.12.xx.xx” on page 122
- “Controller firmware 05.xx.xx.xx” on page 122

**Before you begin:** Read “DS4000 Storage Manager performance planning” on page 14 for information about planning the number of LUNs to map to each partition.

**Controller firmware 06.12.xx.xx:** When mapping LUNs for the first time to a newly-created partition, complete the following steps to map LUNs to the partition.

**Before you begin:** Read “DS4000 Storage Manager performance planning” on page 14 for information about planning the number of LUNs to map to each partition.

**Important::** If your subsystem is running controller firmware 06.12.xx.xx or higher, you can use the Storage Partitioning wizard feature of the Storage Manager task assistant, instead of this procedure, to map LUNs to a new storage partition.

1. Select the Mappings view of the Subsystem Management window.
2. In the Topology section, right-click the host on which you want to map LUNs, and select **Define Storage Partitioning**. The Define Storage Partitioning window opens.
3. In the Define Storage Partitioning window, select **Host**, then click **Next**.
4. Select the logical drive by name, on the right side of the window.
5. Accept the default LUN ID, or change it, then click **Add**.
6. Repeat step 5 for each LUN that you want to map to the partition.

**Controller firmware 05.xx.xx.xx:** Complete the following steps to map LUNs to a new partition:

1. In the Topology section of the Mappings view of the Subsystem Management window, right-click the host on which you want to map LUNs, and select **Define Storage Partitioning**. The Define Storage Partitioning window opens.
2. In the Define Storage Partitioning window, select **Host**, then click **Next**.
3. Select the logical drive by name, on the right side of the window.
4. Accept the default LUN ID, or change it, then click **Add**.
5. Repeat step 4 for each LUN that you want to map to the partition.

## Adding LUNs to an existing partition

When adding LUNs to an existing partition, complete the following steps to map the new LUNs to the partition.

**Before you begin:** Read “DS4000 Storage Manager performance planning” on page 14 for information about planning the number of LUNs to map to each partition.

1. Select the Mappings view of the Subsystem Management window.
2. In the Topology section, right-click the host on which you want to map LUNs, and select **Define Additional Mappings**. The Define Additional Mapping window opens.
3. In the Define Additional Mapping window, select the following options, and then click **Add**:
  - Host group or host
  - Logical unit number (LUN)(0-255)
  - Logical drive

Repeat these steps for each LUN that you want to add to the partition.

---

## Creating direct-attached and SAN-attached configurations

DS4000 Storage Manager supports IBM DS4000 Storage Subsystems in direct-attached Solaris configurations or in a SAN environment through switches in Solaris configurations.

### Creating a direct-attached configuration

In a direct-attached configuration, one or two Solaris servers can be connected to DS4000 storage subsystems.

**Requirements:**

- Two-server DS4400 or DS4500 configurations require four host-side minihubs, each with exactly one fibre channel connection from each HBA to a minihub.

**Note:** DS4100, DS4200, DS4300, DS4700, and DS4800 storage subsystems do not have minihubs.

- No external hubs can be used.

Complete the following steps to set up a direct-attached configuration:

1. Connect the HBAs to each controller or minihub port of the DS4000 storage subsystem.
2. Configure and verify the configuration.

### Creating a SAN-attached configuration

Use the following procedure to create a SAN-attached configuration.

**Requirements:**

- Multiple HBAs within the same server must be isolated from each other if they are connected to the same switch that is connected to the same DS4000 controller port.
- Each HBA and controller port must be in its own fabric zone, if they are connecting through a single switch, such as a 2109-F16.

See the documentation provided by the switch manufacturer for more information about zoning. Multiple DS4000 devices can be configured to the same set of HBAs through a fibre channel switch.

Complete the following steps to set up a SAN-attached configuration:

1. Connect the HBAs to the switch or switches.
2. Connect the DS4000 storage subsystems to the switch or switches.
3. Set the required zones on the fibre channel switch or switches, if applicable.
4. Configure and verify the configuration.

**Note:** For more information about zoning and enabling zones, see Appendix F, “Connecting HBAs in a FC switch environment,” on page 245.

---

## Configuring the host bus adapter cards

Before you can install the failover driver, you must install the HBA driver package and modify the configuration file settings using the following procedures.

- **JNI**
  - “Installing the JNI adapter driver package” on page 124

- “Modifying the HBA settings and binding the HBAs” on page 125 (SAN-attached only)

**Note:** JNI host bus adapters are supported only on Solaris 8 and 9. They are not supported on Solaris 10.

- **QLogic**

- “Installing the QLogic adapter driver package” on page 132
- “Modifying the QLogic HBA settings” on page 134

- **Emulex**

- “Changing the Emulex configuration files” on page 132

**Note:** Find the latest information about operating system and HBA support, clustering support, storage area network (SAN) fabric support, and DS4000 Storage Manager feature support:

<http://www-1.ibm.com/servers/storage/support/fastt/index.html>

## Installing the JNI adapter driver package

The procedures for installing the JNI adapter driver package and modifying the JNI HBA settings both refer to Table 17.

*Table 17. JNI model numbers and configuration files*

JNI HBA model numbers	Configuration files
FC64-1063-N	/kernel/drv/fcaw.conf
FCI-1063-N	/kernel/drv/fca-pci.conf
FCE2-1063, FCE2-1063, FCE-6410, FCE2-6412	/kernel/drv/jnic.conf
FCE-1473, FCE2-1473, FCE-6412 (2 GB), FCE-6460	/kernel/drv/jnic146x.conf

### Before you begin:

1. Ensure that the JNI HBAs have been installed and attached directly to the controllers or to a SAN fabric switch.
2. If attached to SAN fabric switch, ensure that the zones for the DS4000 storage subsystem have been created and enabled.

#### Notes:

- a. All fabric switches must be zoned in such a way that a single HBA can access only one controller per storage array.
  - b. For more information about zoning and enabling zones, see Appendix F, “Connecting HBAs in a FC switch environment,” on page 245.
  - c. JNI host bus adapters are supported only on Solaris 8 and 9. They are not supported on Solaris 10.
3. In the Storage Manager readme file for Solaris, identify the correct driver packages for the installed HBAs. (See “Finding the Storage Manager readme files online” on page 24.)

Complete the following steps to install the JNI adapter driver package:

1. Download the most current HBA driver package, as listed in the Storage Manager readme file for Solaris, from the following Web site:

<http://www.amcc.com/drivers/notice.html>

2. Run the following command to install the JNI adapter driver package:

```
# pkgadd -d adapter_driver_package
```

where *adapter\_driver\_package* is the name of the adapter driver package that you want to install, as in the following example:

```
# pkgadd -d JNIC146x.pkg
```

3. Run the following command to verify that the JNI adapter drive package is installed:

```
# pkginfo adapter_driver_package
```

where *adapter\_driver\_package* is the name of the adapter driver package that you installed, as in the following example:

```
# pkginfo -l JNIC146x.pkg
```

4. Type the following command to reboot the Solaris host:

```
# shutdown -g0 -y -i6
```

## Modifying the HBA settings and binding the HBAs

The loop settings in the JNI configuration file are set by default to private loop for direct-attach configurations. For a SAN-attached configuration that uses a fabric switch, modify the loop settings to bind the HBAs to the DS4000 storage controller before you install the failover driver on the host.

This section contains the following procedures:

- “Modifying the JNI HBA settings for McData, Cisco, CNT, and IBM SAN 1 GB switches”
- “Modifying the JNI HBA settings for a IBM SAN 2 GB switch” on page 128

**Attention:** If you have a direct-attached configuration, skip this section and proceed to “Installing the RDAC failover driver” on page 142 or “Installing the DMP failover driver” on page 144. You do not need to modify JNI HBA settings if you have a direct-attached configuration.

### Modifying the JNI HBA settings for McData, Cisco, CNT, and IBM SAN 1 GB switches

**Before you begin:** Table 17 on page 124 lists the configuration file for each JNI adapter driver package. Also, some of the steps in these procedures refer to Appendix G, “DS4000 Diagnostic Data Capture (DDC),” on page 247.

Complete the following procedures to modify the JNI HBA settings.

#### **Modifying the loop settings:**

1. Run the following commands.

```
# cd /kernel/drv  
# vi JNI_configuration_file
```

where *JNI\_configuration\_file* is the JNI configuration file whose HBA settings you want to modify, as in the following example:

```
# cd /kernel/drv
# vi jnic146x.conf
```

2. In the vi Editor, uncomment and modify the loop attributes using the information that is listed in Appendix G, “DS4000 Diagnostic Data Capture (DDC),” on page 247.
3. Run the following command to save changes made to the JNI configuration file.

```
# :wq
```

4. Run the following command to reboot the Solaris host.

```
# shutdown -g0 -y -i6
```

### **Gathering the binding information:**

1. After the host reboots, run the following commands to gather binding information in the messages log.

```
# cd /var/adm
# more messages
```

The messages log displays, as in the following example:

```
Jul 18 14:33:50 sunburn jnic146x: [ID 550325 kern.notice] jnic146x0:
Hba: JNI,FCR      Model: FCX2-6562
Jul 18 14:33:50 sunburn jnic146x: [ID 277434 kern.notice] jnic146x0:
FCode: Version 3.8.9 [BAFA]
Jul 18 14:33:50 sunburn jnic146x: [ID 188160 kern.notice] jnic146x0:
IRQ: 1 Channel: 1
Jul 18 14:33:50 sunburn jnic146x: [ID 428106 kern.notice] jnic146x0:
SubVend: 1242 Sub: 6562 Rev: b100 Vend: 124 2 Dev: 1560
Jul 18 14:33:50 sunburn jnic146x: [ID 904290 kern.notice] jnic146x0:
WWNN: 1000000173008A2E WWPN: 2000000173008A2E
Jul 18 14:33:51 sunburn jnic146x: [ID 695386 kern.notice] jnic146x0:
Auto-negotiating link speed
Jul 18 14:33:51 sunburn jnic146x: [ID 873028 kern.notice] jnic146x0:
Configured as Private Loop port
Jul 18 14:33:52 sunburn jnic146x: [ID 245684 kern.notice] jnic146x0:
JNIC v5.2.3 (03042900)

Jul 18 14:33:50 sunburn jnic146x: [ID 550325 kern.notice] jnic146x1:
Hba: JNI,FCR      Model: FCX2-6562
Jul 18 14:33:50 sunburn jnic146x: [ID 277434 kern.notice] jnic146x1:
FCode: Version 3.8.9 [BAFA]
Jul 18 14:33:50 sunburn jnic146x: [ID 188160 kern.notice] jnic146x1:
IRQ: 1 Channel: 1
Jul 18 14:33:50 sunburn jnic146x: [ID 428106 kern.notice] jnic146x1:
SubVend: 1242 Sub: 6562 Rev: b100 Vend: 124 2 Dev: 1560
Jul 18 14:33:50 sunburn jnic146x: [ID 904290 kern.notice] jnic146x1:
WWNN: 1000000173009A2E WWPN: 2000000173009A2E
Jul 18 14:33:51 sunburn jnic146x: [ID 695386 kern.notice] jnic146x1:
Auto-negotiating link speed
Jul 18 14:33:51 sunburn jnic146x: [ID 873028 kern.notice] jnic146x1:
Configured as Private Loop port
Jul 18 14:33:52 sunburn jnic146x: [ID 245684 kern.notice] jnic146x1:
JNIC v5.2.3 (03042900)
```

2. Search the messages log for the most recent HBA information. You can do this with a backwards search for the installed HBAs.



```
# /SunOS
```

3. Record the following information about the installed HBAs:

- The JNI driver instances
- The WWPNs

For example, for the output listed above, you would record the following information:

JNI driver instance	WWPN
jnic146x0	2000000173008A2E
jnic146x1	2000000173009A2E

After you finish gathering the binding information, continue to the next procedure, “Binding the HBAs to storage controllers.”

**Binding the HBAs to storage controllers:** The examples in this procedure assume that you are binding two JNIC FCE-6460 HBAs to the DS4000 controllers. Adjust the steps for your specific configuration.

1. Run the following commands to open the JNI configuration file.

```
# cd /kernel/drv  
# vi JNI_configuration_file
```

where *JNI\_configuration\_file* is the name of the JNI configuration file of the HBA that you want to modify.

For example, the following commands open the jnic146x.conf file.

```
# cd /kernel/drv  
# vi jnic146x.conf
```

2. In the file, search for a section called Configuration parameters for target to FC device mappings, as shown in the following example:

```
#####
#
# Configuration parameters for target to FC device mapping:
#
#   targetX_hba,
#   targetX_lunY_hba,
#   targetX_wwnn,
#   targetX_wwpn,
#   targetX_port,
#
# Type: string
# Default:
#
# Example usage: Replace the 'x' characters with actual WWNN, WWPN, or port ID.
#
# target0_hba      = "jnic146x0";
# target0_lun0_hba = "jnic146x0";
# target0_wwnn    = "xxxxxxxxxxxxxxxx";
# target0_wwpn    = "xxxxxxxxxxxxxxxx";
# target0_port     = "xxxxxx";
# jnic146x0-target0_lun0_hba="jnic146x0";
# jnic146x0-target0_wwnn="xxxxxxxxxxxxxxxx";

# Example usage: Replace the 'x' characters with actual WWNN, WWPN, or port ID.
#
# target0_hba      = "jnic146x0";
# target0_lun0_hba = "jnic146x0";
# target0_wwnn    = "xxxxxxxxxxxxxxxx";
# target0_wwpn    = "xxxxxxxxxxxxxxxx";
# target0_port     = "xxxxxx";
# jnic146x0-target0_lun0_hba="jnic146x0";
# jnic146x0-target0_wwnn="xxxxxxxxxxxxxxxx";
```

3. Using the information that you recorded in the previous procedure, “Gathering the binding information” on page 126, add the following parameters to the file for each HBA:

- Targetx\_hba = JNI driver instance
- Targetx\_wwpn = Controller WWPN

For example:

```
Target0_hba = jnic146x0
Target0_wwpn = 2000000173008A2E

Target1_hba = jnic146x1
Target1_wwpn = 2000000173009A2E
```

4. Run the following command to save the changes to the JNI configuration file.

```
# :wq
```

5. Run the following command to reboot the Solaris host.

```
# shutdown -g0 -y -i6
```

### Modifying the JNI HBA settings for a IBM SAN 2 GB switch

If you are using a IBM SAN 2 GB switch, you need to force the HBA (FCC-6460, FCE-1473, or FCE2-1473 operating in 2 GB mode) to be a public loop device.

If you are using any other switch, see “Modifying the JNI HBA settings for McData, Cisco, CNT, and IBM SAN 1 GB switches” on page 125 for the correct modification procedures.

Complete the following procedures to modify the JNI HBA settings.

**Gathering the binding information:**

1. Open the `/var/adm/messages` file by typing the following command:

```
# more /var/adm/messages
```

2. Perform a backwards search of the `/var/adm/messages` file by typing the following command:

```
# /SunOS
```

3. Look for the HBAs in the `/var/adm/messages` file. For example, you might see the following information in the `/var/adm/messages` file:

```
May 6 10:02:11 solar unix: jnic146x0: Port 011000  
(WWN 200200a0b80f478e:200300a0b80f478f) online.  
May 6 10:02:11 solar unix: jnic146x3: Port 610300  
(WWN 200200a0b80f478e:200200a0b80f478f) online.
```

4. Record the following information about the installed HBAs:
  - The JNI driver instances
  - The WWPNs

For example, for the output listed above, you would record the following information:

JNI driver instance	WWPN
jnic146x0	200300a0ba0f478F
jnic146x3	200200a0ba0f478F

5. Record the WWPN for each FCE-6460-N adapter that is installed on the host. In this example, the WWPN is 200300a0ba0f478F for an adapter on target 0, and would be 200200a0ba0f478F for an adapter on target 3:

**Attention:** In the messages file, notice that each adapter has a network port and a port. Do not use the WWPN for the network port; only use the WWPN for the port.

**Opening the JNI configuration file:** The examples in this procedure assume that you are binding two JNIC FCE-6460 HBAs to the controllers.

**Before you begin:** See Appendix G, “DS4000 Diagnostic Data Capture (DDC),” on page 247 and modify settings accordingly.

1. Type the following command:

```
vi /kernel/drv/jnic146x.conf
```

2. In the file, look for the section titled `Parameters: FcLoopEnabled` and `FcFabricEnabled`. Highlight and copy the following text:

```
-jnic 146x0-FcLoopEnabled=1;  
-jnic 146x0-FcFabricEnabled=0;
```

3. Paste the copy immediately following the text that you copied in step 2 on page 129, as shown in the following example:

```
-jnic 146x0-FcLoopEnabled=1;  
-jnic 146x0-FcFabricEnabled=0;  
-jnic 146x0-FcLoopEnabled=1;  
-jnic 146x0-FcFabricEnabled=0;
```

4. Change the target values according to the information that you gathered from the /var/adm/messages file. In this example, one controller is on target 0 and the other controller is on target 3:

```
-jnic 146x0-FcLoopEnabled=1;  
-jnic 146x0-FcFabricEnabled=0;  
-jnic 146x3-FcLoopEnabled=1;  
-jnic 146x3-FcFabricEnabled=0;
```

5. Set the FcLoopEnabled and FcFabricEnabled attributes, as shown in the following example, in which both controllers are attached to a 2 GB switch:

```
-jnic 146x0-FcLoopEnabled=1;  
-jnic 146x0-FcFabricEnabled=1;  
-jnic 146x3-FcLoopEnabled=1;  
-jnic 146x3-FcFabricEnabled=1;
```

**Note:** IBM SAN 2 GB switches (public):

- FcLoopEnable=1
- FcFabricEnable=1

**Binding the HBAs to the storage controllers:** Complete the following steps to set and change the target variables to the specified values:

1. In the jnic146x.conf file, search for a section called Configuration parameters for target to FC device mappings, as shown in the following example:

```
#####
#
# Configuration parameters for target to FC device mapping:
#
#   targetX_hba,
#   targetX_lunY_hba,
#   targetX_wwnn,
#   targetX_wwpn,
#   targetX_port,
#
# Type: string
# Default:
#
# Example usage: Replace the 'x' characters with actual WWNN, WWPN, or port ID.
#
# target0_hba      = "jnic146x0";
# target0_lun0_hba = "jnic146x0";
# target0_wwnn    = "xxxxxxxxxxxxxxxx";
# target0_wwpn    = "xxxxxxxxxxxxxxxx";
# target0_port     = "xxxxxx";
# jnic146x0-target0_lun0_hba="jnic146x0";
# jnic146x0-target0_wwnn="xxxxxxxxxxxxxxxx";

# Example usage: Replace the 'x' characters with actual WWNN, WWPN, or port ID.
#
# target0_hba      = "jnic146x0";
# target0_lun0_hba = "jnic146x0";
# target0_wwnn    = "xxxxxxxxxxxxxxxx";
# target0_wwpn    = "xxxxxxxxxxxxxxxx";
# target0_port     = "xxxxxx";
# jnic146x0-target0_lun0_hba="jnic146x0";
# jnic146x0-target0_wwnn="xxxxxxxxxxxxxxxx";
```

2. Using the information that you recorded in the previous procedure, “Gathering the binding information” on page 129, add the following parameters to the file for each HBA:

- Targetx\_hba = JNI driver instance
- Targetx\_wwpn = Controller WWPN

For example:

```
Target0_hba = jnic146x0
Target0_wwpn = 200300a0ba0f478F

Target1_hba = jnic146x3
Target1_wwpn = 200200a0ba0f478F
```

3. Type the following command to save the changes to the JNI configuration file:

```
# :wq
```

4. Type the following command to reboot and configure the Solaris host:

```
# shutdown -g0 -y -i6
```

When you are finished, install the failover driver on the host. See “Installing the RDAC failover driver” on page 142 or “Installing the DMP failover driver” on page 144 for more information.

## Changing the Emulex configuration files

For more detailed information about using Emulex HBAs, see the DS4000 Storage Manager readme file for Solaris. For steps for finding the readme file on the Web, see “Finding the Storage Manager readme files online” on page 24.

Also, you can find the latest information about operating system and HBA support, clustering support, storage area network (SAN) fabric support, and DS4000 Storage Manager feature support:

<http://www-1.ibm.com/servers/storage/support/fastt/index.html>

### Before you begin:

- Ensure that the Emulex HBAs have been installed, and are attached either directly to the controllers or to the SAN fabric switch.
- If the HBAs are attached to a SAN fabric switch, ensure that the zones for the DS4000 storage subsystem are created and enabled.

### Notes:

1. All fabric switches must be zoned in such a way that a single HBA can access only one controller per storage array.
2. For more information about zoning and enabling zones, see Appendix F, “Connecting HBAs in a FC switch environment,” on page 245.

Ensure that the following `/kernel/drv/lpfc.conf` file parameters are set to the correct values:

Table 18. `/kernel/drv/lpfc.conf` settings for using Emulex HBAs

<code>/kernel/drv/lpfc.conf</code> parameter	Value
No-device-delay	0
Network-on	0
Linkdown-tmo	60
Nodev-tmo	60

## Installing the QLogic adapter driver package

This section describes how to install the QLogic adapter driver package.

### Before you begin:

- Ensure that the QLogic HBAs have been installed, and are attached either directly to the controllers or to the SAN fabric switch.
- If the HBAs are attached to a SAN fabric switch, ensure that the zones for the DS4000 storage subsystem are created and enabled.

### Notes:

1. All fabric switches must be zoned in such a way that a single HBA can access only one controller per storage array.
2. For more information about zoning and enabling zones, see Appendix F, “Connecting HBAs in a FC switch environment,” on page 245.

Complete the following steps to install the QLogic adapter driver package.

1. Download the most current adapter driver package from the following Web site to a local directory on the host:

www.QLogic.com

2. Un-compress the QLogic adapter driver package, by typing the following command:

```
# unzip qlogic_adapter_driver.
```

where *qlogic\_adapter\_driver* is the name of the compressed adapter driver (for example, *qla2300\_pkg\_v408.Z*).

3. Install the QLogic adapter driver package, by typing the following command:

```
# pkgadd -d adapter_driver_pkg
```

where *adapter\_driver\_pkg* is the name of the package that you want to install (for example, *qla2300\_pkg\_408*). A package installation menu displays.

4. From the package installation menu, select package 3:

```
3. QLA2300-3 QLogic QLA23000 driver
   (Sparc) Solaris 8-9, Rev=4.08
```

**Note:** You do not need to install any of the QLSDDLIB packages that display in the package installation menu.

5. Follow the instructions in the package installation utility to install the QLogic adapter driver package.

**Note:** When the following screen displays, press **Enter** to install the driver object in the default directory (*/kernel/drv*):

```
Where do you want the driver object installed?
[default = /kernel/drv]
```

6. Verify that the QLogic adapter package is installed, by typing the following command:

```
# pkginfo -l pkg_version
```

where *pkg\_version* is the name of the adapter driver package that you installed (for example, *QLA2300-3*).

7. The following screen displays. Type *y*, then press **Enter**.

```
Do you want to continue with the installation of the pkg_version?
[y, n, ?]
```

where *pkg\_version* is the name of the adapter driver package that you installed (for example, *QLA2300-3*).

8. Reboot the Solaris host, by typing the following command:

```
# shutdown -g0 -y -i6
```

When you are done, go to the next procedure, “Verifying the HBA installation.”

## Verifying the HBA installation

Complete the following steps to verify that the HBAs are installed:

1. Type the following command:

```
# view /var/adm/messages
```

- A list of administrative messages displays.
2. Scroll down the list until you see the HBAs listed.
  3. Record the WWPN and the HBA number for each of the two HBA cards.

When you are done, go to the next procedure, “Modifying the QLogic HBA settings.”

## Modifying the QLogic HBA settings

Complete the following steps to modify the QLogic HBA settings:

1. Open the QLogic configuration file, by typing the following commands:

```
# cd /kernel/drv
# vi QLogic_conf_file.conf
```

where *QLogic\_conf\_file.conf* is the name of the QLogic configuration file (for example, *qla2300.conf*).

2. In the vi Editor, uncomment and modify the loop attributes on each of the two QLogic HBA cards, using the information that is listed in Appendix G, “DS4000 Diagnostic Data Capture (DDC),” on page 247.
3. Save the changes to the QLogic configuration file, by typing the following command:

```
# :wq
```

4. Reboot the Solaris host, by typing the following command:

```
# shutdown -g0 -y -i6
```

When you are finished, install the failover driver, as described in the next section.

---

## Installing a failover driver on Solaris

A failover driver monitors I/O paths. If a component failure occurs in one of the fibre channel paths, the failover driver reroutes all I/O to another path.

Solaris host systems require one of the following failover drivers:

- Solaris Multiplexed I/O (MPxIO)
- RDAC
- VERITAS VolumeManager with Dynamic Multipathing (DMP)

### Notes:

1. RDAC is not supported on Solaris 10. You must use either Solaris MPxIO or the VERITAS DMP failover driver.
2. With Solaris 10, MPxIO capability is built in. If you want to use MPxIO with previous versions of Solaris, you must install SUN StorEdge SAN Foundation Suite.

This section includes the following procedures:

- “Enabling the MPxIO failover driver” on page 135
- “Installing the RDAC failover driver” on page 142
- “Installing the DMP failover driver” on page 144



## Enabling the MPxIO failover driver

Multiplexed I/O (MPxIO) is a Sun Solaris multipath driver architecture. This failover driver enables storage arrays to be accessed through multiple host controller interfaces from a single instance of the storage array. MPxIO helps protect against storage subsystem outages because of controller failures. If one controller fails, MPxIO automatically switches to an alternate controller.

MPxIO is fully integrated within the Solaris 10 operating system. For Solaris 8 and 9 operating systems, MPxIO is available as part of the Sun StorEdge SAN Foundation Suite (version 4.4.11 or later), and must be installed separately.

For the latest supported version of Sun StorEdge SAN Foundation Suite, the latest Solaris kernel patches, and the most recent updates to information about using MPxIO, check the DS4000 Storage Manager readme file for Solaris. (See “Readme files and concepts” on page 1 for steps for finding the readme file on the Web.)

This section contains the following topics:

- “Device name change considerations for MPxIO”
- “Acquiring the latest MPxIO driver version”
- “Steps for enabling the MPxIO failover driver” on page 136
- “Disabling the MPxIO multipath driver” on page 142

**Note:** For more information, please refer to the following Sun documents, which you can find at the Sun Web site:

<http://docs.sun.com>

- *Sun StorEdge SAN Foundation Software Installation Guide*
- *Sun StorEdge SAN Foundation Software Configuration Guide*
- *Sun Solaris Fibre Channel and Storage Multipathing Administration Guide*

### Device name change considerations for MPxIO

In the `/dev` and `/devices` trees, devices are named differently from their original names when MPxIO is enabled. For example:

#### Device name with MPxIO disabled

`/dev/dsk/c1t1d0s0`

#### MPxIO-enabled device name

`/dev/rdisk/c0t600A0B800011121800006B31452CC6A0d0s2`

Therefore, you must configure applications that directly consume device to use the new names whenever the MPxIO configuration is enabled or disabled.

In addition, the `/etc/vfstab` file and the dump configuration also contain references to device names. When you use the `stmsboot` command to enable or disable MPxIO, as described in the next sections, `/etc/vfstab` and the dump configuration are automatically updated with the new device names.

### Acquiring the latest MPxIO driver version

The method of acquiring MPxIO depends upon which version of Solaris you have installed, as described in the following list:

#### Solaris 10

MPxIO is fully-integrated within the Solaris 10 operating system, and does

not need to be installed separately. MPxIO with Solaris 10 is updated using regular Solaris 10 patches, which are available at the following Sun Technical Support Web site:

<http://sunsolve.sun.com>

**Note:** It is recommended that you install the regular kernel jumbo patch, because there are dependencies between the various patches that make up the driver stack.

### **Solaris 8 and 9**

Because MPxIO is not included with Solaris 8 and 9, you must download the required SAN suite (Sun StorEdge SAN Foundation Suite) from the Sun Technical Support Web site:

<http://sunsolve.sun.com>

On this page, click **SAN 4.4 release Software/Firmware Upgrades & Documentation**.

**Note:** Install the software using the provided `install_it.ksh` script.

### **Steps for enabling the MPxIO failover driver**

This section describes how to enable MPxIO by using the `stmsboot` command. In addition to enabling MPxIO, this command also updates the device names in the `/etc/vfstab` file and the dump configuration files during the next reboot.

**Note:** In Solaris 10, the `stmsboot` command is used to enable or disable MPxIO on all devices.

#### **Before you begin:**

1. Install the Solaris operating system, and the latest patches.
2. Ensure that the Solaris host type was selected when the host was defined. See “Steps for defining the host and host port” on page 120 for more information.

#### **Steps for enabling MPxIO on Solaris 8 and 9:**

1. Install the latest version of Sun StorEdge SAN Foundation Suite and required patches, using the Sun StorEdge `install_it` script. For more information, see the Sun StorEdge SAN Foundation Suite *x.xx* Installation Guide (where *x.xx* is the version of StorEdge software).
2. Edit the `/kernel/drv/scsi_vhci.conf` configuration file to ensure that the VID/PID is not specified in this file. Also, ensure that the following entries exist in the file:

```
mpxio-disable="no";  
load-balance="none";  
auto-failback="enable";
```

**Exception:** In a cluster environment where logical drives (LUNs) are shared between multiple Sun servers, you might need to set the `auto-failback` parameter to `disable` to prevent the following phenomenon, which can occur when one of the servers has a failed path to one of the shared LUNs:

If a host in a cluster server configuration loses a physical path to a DS4000 storage subsystem controller, LUNs that are mapped to the cluster group can periodically failover and then failback between cluster nodes until the failed path is restored. This behavior is the result of the automatic logical drive failback feature of the multipath driver. The cluster node with a failed path to a DS4000 controller issues a failover command for all LUNs that were mapped to the cluster group to the controller that it can access. After a programmed interval, the nodes that did not have a failed path will issue a failback command for the

LUNs because they can access the LUNs on both controllers, resulting in the cluster node with the failed path not being able to access certain LUNs. This cluster node will then issue a failover command for all LUNs, repeating the LUN failover-failback cycle.

**Note:** See the latest DS4000 interoperability matrix at the following Web page for supported cluster services:

[www-1.ibm.com/servers/storage/disk/ds4000/interop-matrix.html](http://www-1.ibm.com/servers/storage/disk/ds4000/interop-matrix.html)

3. If you made any changes to the `/kernel/drv/scsi_vhci.conf` file in the previous step, save the file and reboot the server using the following command:

```
# shutdown -g0 -y -i6
```

4. If needed, update the fibre channel HBA firmware.
5. Create the DS4000 logical drives and map them to the fibre channel HBA ports in the Sun servers.

**Steps for enabling MPxIO on Solaris 10: Before you begin:** Keep in mind the following considerations for `stmsboot -e [enable] -d [disable] and -u [update]`:

- When you run the `stmsboot` command, it is recommended that you accept the default to Reboot the system now.
- The `stmsboot` command saves copies of the original `/kernel/drv/fp.conf` and `/etc/vfstab` files before modifying them, so you can use the saved files to recover from any unexpected problems.
- Ensure that the `eprom` boot device is set to boot from the current boot device.

Complete the following steps to enable MPxIO on all fibre channel devices:

1. Run the `stmsboot -e` command, and select the default `[y]` to reboot the system:

```
# stmsboot -e

WARNING: This operation will require a reboot.
Do you want to continue ? [y/n] (default: y) y
The changes will come into effect after rebooting the system.
Reboot the system now ? [y/n] (default: y) y
```

**Note:** During the reboot, `/etc/vfstab` and the dump configuration are updated to reflect the device name changes.

2. After the reboot, configure your applications to use new device names, as explained in “Device name change considerations for MPxIO” on page 135.
3. If necessary, edit the `/kernel/drv/fp.conf` configuration file to verify that the following parameter is set as follows:

```
mpxio-disable="no";
```

Edit the `/kernel/drv/scsi_vhci.conf` configuration file to verify that the following parameters are set as follows:

```
load-balance="none";
auto-failback="enable";
```

4. If you made any changes to configuration files in the previous step, save the file, and reboot the server using the following command:

```
# shutdown -g0 -y -i6
```

5. If needed, update the fibre channel HBA firmware.
6. Create the DS4000 logical drives and map them to the fibre channel HBA ports in the Sun servers.

### Verifying devices and configuring failover/failback path for the mapped LUNs

1. Verify devices using the **cfgadm -al** command to display about the host ports and their attached devices:

```
# cfgadm -al
Ap_Id                Type                Receptacle  Occupant  Condition
PCI0                 vgs8514/hp         connected   configured ok
PCI1                 unknown            empty       unconfigured unknown
PCI2                 unknown            empty       unconfigured unknown
PCI3                 mult/hp            connected   configured ok
PCI4                 unknown            empty       unconfigured unknown
PCI5                 unknown            empty       unconfigured unknown
PCI6                 unknown            empty       unconfigured unknown
PCI7                 mult/hp            connected   configured ok
PCI8                 mult/hp            connected   configured ok
c0                   scsi-bus            connected   configured unknown
c0::dsk/c0t6d0       CD-ROM              connected   configured unknown
c1                   fc-private          connected   configured unknown
c1::500000e0106fca91 disk                 connected   configured unknown
c1::500000e0106fcde1 disk                 connected   configured unknown
c1::500000e0106fcf31 disk                 connected   configured unknown
c1::500000e0106fd061 disk                 connected   configured unknown
c1::500000e0106fd7b1 disk                 connected   configured unknown
c1::500000e0106fdaa1 disk                 connected   configured unknown
c1::50800200001d9841 ESI                  connected   configured unknown
c2                   fc-fabric           connected   configured unknown
c2::201400a0b811804a disk                 connected   configured unusable
c2::201400a0b8118098 disk                 connected   configured unusable
c2::201700a0b8111580 disk                 connected   configured unusable
c3                   fc-fabric           connected   configured unknown
c3::201500a0b8118098 disk                 connected   configured unusable
c3::201600a0b8111580 disk                 connected   configured unusable
c3::202500a0b811804a disk                 connected   configured unusable
c4                   fc-fabric           connected   configured unknown
c4::200400a0b80f1285 disk                 connected   configured unknown
c4::200400a0b8127a26 disk                 connected   configured unusable
c5                   fc-fabric           connected   configured unknown
c5::200400a0b82643f5 disk                 connected   unconfigured unknown
c5::200500a0b80f1285 disk                 connected   configured unknown
c5::200500a0b8127a26 disk                 connected   configured unusable
c5::200c00a0b812dc5a disk                 connected   configured unknown
usb0/1               usb-kbd             connected   configured ok
usb0/2               usb-mouse           connected   configured ok
usb0/3               unknown             empty       unconfigured ok
usb0/4               unknown             empty       unconfigured ok
#
```

2. You can also display information about the attachment points on a system. In the following example, c0 represents a fabric-connected host port, and c1 represents a private, loop-connected host port. (Use the **cfgadm** command to manage the device configuration on fabric-connected host ports.)

By default, the device configuration on private, loop-connected host ports is managed by Solaris host.

**Note:** The **cfgadm -l** command displays information about fibre channel host ports. Also use the **cfgadm -al** command to display information about fibre channel devices. The lines that include a port World Wide Name

(WWN) in the Ap\_Id field associated with c0 represent a fabric device. Use the **cfgadm configure** and **cfgadm unconfigure** commands to manage those devices and make them available to Solaris hosts.

```
# cfgadm -l
Ap_Id      Type      Receptacle  Occupant  Condition
c0         fc-fabric connected  unconfigured unknown
c1         fc-private connected  configured unknown
```

3. Configure the device using the following command:

```
cfgadm -c configure Ap-Id
```

The Ap\_ID argument specifies the attachment point ID of the configured fibre channel devices. This ID can be the controller number and WWN of a device (for example, c3::50020f230000591d).

See the output example in step 1. Also, see the `cfgadm` man page for an explanation of attachment points.

**Note:** An Ap\_Id with type `fc-private` cannot be unconfigured. Only type `fc-fabric` can be configured and unconfigured.

4. Use the **luxadm probe** command to list all mapped LUNs:

```
# luxadm probe
luxadm probe
No Network Array enclosures found in /dev/es

Node WWN:200400a0b8111218 Device Type:Disk device
  Logical Path:/dev/rdisk/c0t600A0B80001121800006ADE452CBC62d0s2
Node WWN:200400a0b8111218 Device Type:Disk device
  Logical Path:/dev/rdisk/c0t600A0B80001121800006ADF452CBC6Ed0s2
Node WWN:200400a0b8111218 Device Type:Disk device
  Logical Path:/dev/rdisk/c0t600A0B80001121800006AE0452CBC7Ad0s2
Node WWN:200400a0b8111218 Device Type:Disk device
  Logical Path:/dev/rdisk/c0t600A0B80001121800006AE1452CBC88d0s2
Node WWN:200400a0b8111218 Device Type:Disk device
  Logical Path:/dev/rdisk/c0t600A0B80001121800006AE2452CBC94d0s2
Node WWN:200400a0b8111218 Device Type:Disk device
  Logical Path:/dev/rdisk/c0t600A0B80001121800006AE3452CBCA0d0s2
Node WWN:200400a0b8111218 Device Type:Disk device
  Logical Path:/dev/rdisk/c0t600A0B80001121800006AE4452CBCACd0s2
Node WWN:200400a0b8111218 Device Type:Disk device
  Logical Path:/dev/rdisk/c0t600A0B80001121800006AE5452CBCB8d0s2
Node WWN:200400a0b8111218 Device Type:Disk device
  Logical Path:/dev/rdisk/c0t600A0B80001121800006AE6452CBC4d0s2
Node WWN:200400a0b8111218 Device Type:Disk device
  Logical Path:/dev/rdisk/c0t600A0B80001121800006AE7452CBCD2d0s2
Node WWN:200400a0b8111218 Device Type:Disk device
  Logical Path:/dev/rdisk/c0t600A0B80001121800006AE8452CBCDEd0s2
Node WWN:200400a0b8111218 Device Type:Disk device
  Logical Path:/dev/rdisk/c0t600A0B80001121800006AE9452CBCEAd0s2
Node WWN:200400a0b8111218 Device Type:Disk device
  Logical Path:/dev/rdisk/c0t600A0B80001121800006AEA452CBCF8d0s2
Node WWN:200400a0b8111218 Device Type:Disk device
  Logical Path:/dev/rdisk/c0t600A0B80001121800006AEB452CBD04d0s2
Node WWN:200400a0b8111218 Device Type:Disk device
  Logical Path:/dev/rdisk/c0t600A0B80001121800006AEC452CBD10d0s2
Node WWN:200400a0b8111218 Device Type:Disk device
  Logical Path:/dev/rdisk/c0t600A0B80001121800006AED452CBD1Ed0s2
Node WWN:200400a0b8111218 Device Type:Disk device
  Logical Path:/dev/rdisk/c0t600A0B80001121800006B2A452CC65Cd0s2
Node WWN:200400a0b8111218 Device Type:Disk device
  Logical Path:/dev/rdisk/c0t600A0B80001121800006B2B452CC666d0s2
Node WWN:200400a0b8111218 Device Type:Disk device
  Logical Path:/dev/rdisk/c0t600A0B80001121800006B2C452CC670d0s2
Node WWN:200400a0b8111218 Device Type:Disk device
  Logical Path:/dev/rdisk/c0t600A0B80001121800006B2D452CC67Ad0s2
Node WWN:200400a0b8111218 Device Type:Disk device
  Logical Path:/dev/rdisk/c0t600A0B80001121800006B31452CC6A0d0s2
Node WWN:200400a0b8111218 Device Type:Disk device
  Logical Path:/dev/rdisk/c0t600A0B80001121800006B32452CC6ACd0s2
Node WWN:200400a0b8111218 Device Type:Disk device
  Logical Path:/dev/rdisk/c8t201400A0B8111218d7s2
```

5. You can then use the **luxadm display logical path** command to list more details on each mapped LUN, including the number of paths to each LUN. The following example uses a logical path from the previous example:

```

# luxadm display /dev/rdisk/c0t600A0B800011121800006B31452CC6A0d0s2
DEVICE PROPERTIES for disk: /dev/rdisk/c0t600A0B800011121800006B31452CC6A0d0s2
Vendor:                IBM
Product ID:            1742-900
Revision:              0914
Serial Num:            1T51207691
Unformatted capacity: 1024.000 MBytes
Write Cache:           Enabled
Read Cache:            Enabled
  Minimum prefetch:    0x0
  Maximum prefetch:    0x0
Device Type:           Disk device
Path(s):

/dev/rdisk/c0t600A0B800011121800006B31452CC6A0d0s2
/devices/scsi_vhcsi/ssd@g600a0b800011121800006b31452cc6a0:c,raw
Controller             /devices/pci@7c0/pci@0/pci@8/SUNW,q1c@0,1/fp@0,0
Device Address         201400a0b8111218,1e
Host controller port WWN 210100e08ba0fca0
Class                  secondary
State                  STANDBY
Controller             /devices/pci@7c0/pci@0/pci@8/SUNW,q1c@0,1/fp@0,0
Device Address         201500a0b8111218,1e
Host controller port WWN 210100e08ba0fca0
Class                  primary
State                  ONLINE
Controller             /devices/pci@7c0/pci@0/pci@8/SUNW,q1c@0/fp@0,0
Device Address         201400a0b8111218,1e
Host controller port WWN 210000e08b80fca0
Class                  secondary
State                  STANDBY
Controller             /devices/pci@7c0/pci@0/pci@8/SUNW,q1c@0/fp@0,0
Device Address         201500a0b8111218,1e
Host controller port WWN 210000e08b80fca0
Class                  primary
State                  ONLINE
#

```

## Unconfiguring a failover/failback path

Before you unconfigure a fabric device, stop all activity to the device and unmount any file systems on the fabric device. (See your Solaris administration documentation for unmounting procedures.)

To unconfigure a failover/failback path, complete the following steps:

1. Run the **cfgadm -al** command to display information about the host ports and their attached devices.
2. Unconfigure the LUN by running the following command:

```
cfgadm -c unconfigure Ap-Id
```

Where Ap\_Id is the LUN that you want to unconfigure.

3. Run the **cfgadm -al** command again, to verify that the LUN is now unconfigured.
4. If necessary, define the file structure using the **newfs** command. Add entries to the `/etc/vfstab` file.
5. Reboot the server using the following command:

```
# shutdown -g0 -y -i6
```

## Disabling the MPxIO multipath driver

For Solaris 10, unconfigure all devices using the **cfgadm -c unconfigure AP-id Ap-id** command. Then, run the **stmsboot -d** command, and accept the default to Reboot the system now.

For Solaris 8 and 9, unconfigure all devices using the **cfgadm -c unconfigure AP-id Ap-id** command, and edit the `/kernel/drv/scsi_vhci.conf` configuration file to set the value of the `mpxio-disable` parameter to `yes`. Then, reboot the system.

To learn how to revert the patches or the StorEdge software, please see the *Sun StorEdge SAN Foundation Installation Software Guide* at

<http://docs.sun.com>.

## Installing the RDAC failover driver

This section describes how to install RDAC on a Solaris host.

### Before you begin::

1. Because you cannot run both RDAC and MPxIO, make sure that MPxIO is disabled. Check the configuration files (`/kernel/drv/scsi_vhci.conf` and/or `/kernel/drv/fp.conf`) and make sure that the value of the `mpxio-disable` parameter is set to `Yes`.
2. You must install an HBA driver package before you install RDAC. If you have a SAN-attached configuration, you must also modify the HBA's configuration file before you install RDAC. If you fail to follow the procedures in this order, problems can occur.

For information about how to install the HBA driver packages and modify the settings, see "Configuring the host bus adapter cards" on page 123.

### Notes:

1. RDAC is only supported on Solaris 8 and 9. (RDAC is *not* supported on Solaris 10.)
2. Modifying failover settings in the HBA's configuration file after installing RDAC requires the removal of the RDAC from the host.

## Steps for installing the RDAC failover driver

**Important:** In some configurations, a patch is required for RDAC to function properly. Before you begin the RDAC installation, check the DS4000 Storage Manager readme file for Solaris to find out whether the patch is required for your specific configuration. In addition, you can find the latest RDAC versions and other important information in the readme file. (For steps for finding the readme file on the Web, see "Finding the Storage Manager readme files online" on page 24.)

Complete the following steps to install RDAC:

1. Insert the Solaris installation CD in the CD-ROM drive.

**Note:** In this procedure, the installation CD is mounted at `/cdrom/SM91`. Modify these commands as needed for your installation.

2. Type the following command to start installing the RDAC package:

```
# pkgadd -d path/filename.pkg
```

where *path/filename* is the directory path and name of the package that you want to install.



The installation process begins.

Information about packages that can be installed in the specified directory is displayed on the command line, as in the following example:

```
The following packages are available:

1 RDAC                               Redundant Disk Array Controller
                                   (sparc) version number

Select package(s) you wish to process (or 'all' to process all
packages). (default:all) [?,??,q]:
```

3. Type the value of the package you are installing and press **Enter**.

The installation process begins.

4. The software automatically checks for package conflicts. If any conflicts are detected, a message is displayed indicating that some files are already installed and are in use by another package.

The following prompt is displayed:

```
Do you want to install these conflicting files [y, n, ?]
```

Type **y** and press **Enter**.

5. The following prompt is displayed:

```
This package contains scripts which will be executed with super-user
permission during the process of installing this package.

Do you want to continue with the installation of <RDAC>

[y, n, ?]
```

Type **y** and press **Enter**.

The installation process continues.

6. When the RDAC package has been successfully installed, the following message is displayed:

```
Installation of <RDAC> was successful.
```

Ensure that the variables in the configuration files for the JNI adapter cards have been set to the correct values. For information about these configuration files and their variables, see “Modifying the HBA settings and binding the HBAs” on page 125.

7. Reboot the Solaris host by typing the following command:

```
# shutdown -g0 -y -i6
```

**Attention:** Any modifications to the persistent bindings in the `jnic146x.conf` configuration file requires the removal of RDAC. After the RDAC is removed you can modify the persistent bindings in the `jnic146x.conf` file, and then reinstall RDAC.

Complete the following steps to modify the `sd.conf` or `jnic146x.conf` files:

1. Remove RDAC by typing the following command:

```
# pkgrm RDAC_driver_pkg_name
```

where *RDAC\_driver\_pkg\_name* is the name of the RDAC driver package that you want to remove.

2. Verify RDAC drive package removal by typing the following command:

```
# pkginfo RDAC_driver_pkg_name
```

where *RDAC\_driver\_pkg\_name* is the name of the RDAC driver package that you removed.

3. Reboot the Solaris host by typing the following command:

```
# shutdown -g0 -y -i6
```

4. Modify persistent bindings in the *sd.conf* or edit the *sd.conf* file by typing the following command:

```
# vi /kernel/drv/jnic146x.conf or sd.conf
```

When you have finished making changes, run the following command to save the changes:

```
# :wq
```

5. Install the RDAC driver package by typing the following command:

```
# pkgadd -d RDAC_driver_pkg_name
```

where *RDAC\_driver\_pkg\_name* is the name of the RDAC driver package that you want to install.

6. Verify package installation by typing the following command:

```
# pkginfo RDAC_driver_pkg_name
```

where *RDAC\_driver\_pkg\_name* is the name of the RDAC driver package that you installed.

7. Reboot the Solaris host by typing the following command:

```
# shutdown -g0 -y -i6
```

**Note:** You must reboot the host after modifying the *jnic146x.conf* file, because the *jnic146x.conf* driver is only read during the boot process. Failure to reboot the host might result in some devices being inaccessible.

## Installing the DMP failover driver

This section describes how to install VERITAS Dynamic Multipathing (DMP), which is a failover driver for Solaris hosts. While RDAC allows you to have only 32 LUNs, DMP allows you to have up to 256 LUNs.

**Important** This section refers to the following Web site for some installation procedures:

[www.veritas.com](http://www.veritas.com)

### System requirements

Ensure that your system meets the following requirements for installing DMP:

- Solaris operating system

- VERITAS VolumeManager 4.0, 4.1
- SMibmasl.pkg (enables Solaris to recognize the DS4000 machine type)

### DMP installation overview

Ensure that your system meets the following prerequisites for installing DMP:

- The HBAs are installed on the Solaris host.
- The parameter settings in the HBA configuration file (for example, jnic146x.conf) are modified.
- In a SAN environment, bindings are configured.
- The zones are created and enabled for the Solaris partition.
- Storage is mapped to the Solaris partition.

**Note:** For more information about zoning and enabling zones, see Appendix F, “Connecting HBAs in a FC switch environment,” on page 245.

Perform the following procedures, in the order listed, to complete the DMP installation:

1. “Preparing for VERITAS DMP installation”
2. “Installing VERITAS VolumeManager packages for DMP” on page 147
3. “Installing the SMibmasl software package” on page 147
4. “Configuring VERITAS VolumeManager” on page 147
5. “Starting the VERITAS Enterprise Administrator” on page 147

### Preparing for VERITAS DMP installation

Complete the following steps to prepare the host for installing VERITAS DMP:

1. Choose the Solaris host on which you want to install DMP.
2. Manually define the targets and LUNs in the `/kernel/drv/sd.conf` file, by completing the following steps.

By default, the `/kernel/drv/sd.conf` file defines targets 0, 1, 2, and 3. LUN0 also is defined for targets 0, 1, 2, and 3.

**Notes:**

- Each target represents a controller to a subsystem, and each LUN represents a logical drive.
- If you are adding additional target or LUN definitions to the `/kernel/drv/sd.conf` file for an existing DMP configuration, be sure to reboot the Solaris host.
  - a. Open the `/kernel/drv/sd.conf` file with the vi Editor, by typing the following command:

```
# vi /kernel/drv/sd.conf
```

The file looks similar to the following example:

```
#
# Copyright (c) 1992, Sun Microsystems, Inc.
#
# ident "@(#)sd.conf 1.9 98/01/11 SMI"

name="sd" class="scsi" class_prop="atapi"
target=0 lun=0;

name="sd" class="scsi" class_prop="atapi"
target=1 lun=0;

name="sd" class="scsi" class_prop="atapi"
target=2 lun=0;

name="sd" class="scsi" class_prop="atapi"
target=3 lun=0;
```

- b. Add additional target and LUN definitions, using the vi Editor. In the following example, it is assumed that the Solaris host is attached to one DS4000 subsystem with three LUNs mapped to the DS4000 storage partition. In addition, the access LUN must be mapped to the partition.

```
#
# Copyright (c) 1992, Sun Microsystems, Inc.
#
# ident "@(#)sd.conf 1.9 98/01/11 SMI"

name="sd" class="scsi" class_prop="atapi"
target=0 lun=0;

name="sd" class="scsi" class_prop="atapi"
target=1 lun=0;

name="sd" class="scsi" class_prop="atapi"
target=2 lun=0;

name="sd" class="scsi" class_prop="atapi"
target=3 lun=0;

name="sd" class="scsi" target=0 lun=1;
name="sd" class="scsi" target=0 lun=2;
name="sd" class="scsi" target=0 lun=3;
name="sd" class="scsi" target=0 lun=31;
name="sd" class="scsi" target=1 lun=1;
name="sd" class="scsi" target=1 lun=2;
name="sd" class="scsi" target=1 lun=3;
name="sd" class="scsi" target=1 lun=31;
```

- c. Save the new entries in the /kernel/drv/sd.conf file, by typing the following command:

```
# :wq
```

3. Verify that RDAC is not installed on the host, by typing the following command:

```
# pkginfo -l RDAC
```

4. If RDAC is installed, remove it by typing the following command:

```
# pkgrm RDAC
```

5. Verify that a host partition has been created. If not, create one by following the procedure that is described in “Creating storage partitions” on page 119.

**Attention:** Set the host port type to Solaris with DMP. Failure to do so results in an inability to map for more than the RDAC limit of 32 LUNs and causes other undesired results.

6. Ensure that all of the paths are optimal and are in a preferred path state from the SMclient.
7. Reboot the host and ensure that the devices show up by typing the following command:

```
# SMdevices
```

8. Verify that you have a 1 GB logical drive available for the rootdg.
9. Label the logical drive that you are using for the rootdg, by typing the following command:

```
# format
```

10. Reboot the Solaris host, by typing the following command:

```
# shutdown -g0 -y -i6
```

## Installing VERITAS VolumeManager packages for DMP

Before you begin to install VERITAS VolumeManager packages for DMP, ensure that you have the VERITAS VolumeManager license key and any other VERITAS licenses that you want to install available during the installation process. This document does not describe how to install the VERITAS product.

For VERITAS VolumeManager installation procedures, see the VERITAS product documentation for Solaris at the following Web site:

[www.veritas.com](http://www.veritas.com)

## Installing the SMibmasl software package

Complete the following steps to install the SMibmasl software package:

1. Install the SMibmasl package, by typing the following command:

**Tip:** You can select either the default (all), or select option 1.

```
# pkgadd -d SMibmasl_pkg
```

2. Reboot the Solaris host, by typing the following command:

```
# shutdown -g0 -y -i6
```

## Configuring VERITAS VolumeManager

This document does not describe how to configure the VERITAS product. For VERITAS VolumeManager configuration procedures, see the VERITAS product documentation for Solaris at the following Web site:

[www.veritas.com](http://www.veritas.com)

## Starting the VERITAS Enterprise Administrator

After you have installed the VERITAS packages, and configured the rootdg, you must stop and restart the VERITAS Enterprise Administrator (VEA).

**Tip:** VEA starts automatically after a reboot.

For these procedures, see the VERITAS product documentation for Solaris at the following Web site:

www.veritas.com

In addition, see the VERITAS documentation for information about how to complete the following tasks:

- Start VERITAS
- Set up disk groups
- Create volumes
- Create file systems
- Mount file systems

---

## Verifying external storage

After you install the failover driver, complete the following steps to verify that the host recognizes the external storage.

**Before you begin:** SMutil must be installed on the host to enable the **SMdevices** and **hot\_add** commands, which you use in the following procedure. For information about how to install SMutil, see “Steps for installing SMutil software (required)” on page 114.

**Restriction:** Do not delete the access LUN or the access logical drive. RDAC uses the access LUN for communication between controllers and DS4000 Storage Manager. Therefore, a storage subsystem with two controllers would require two access LUNs. The access LUN is typically assigned the LUN number 31, by default.

1. Run the following command to verify that the host recognizes the external DS4000 storage:

```
# /opt/IBM_FAStT/util/SMdevices
```

You must see two access LUNs, and all the configured storage (logical drives). If any of these are missing, run the following command:

```
# /etc/raid/bin/hot_add
```

2. Run the following command to verify that SMutil and the host both recognize all the configured storage:

```
# format
```

You must see two access LUNs, and all configured storage (logical drives). If you still do not see all the storage, check the following:

- Recheck the zones.
- Ensure that the zones have been enabled.
- Recheck the targets and WWPNs.
- Check to see if the DS4000 Controllers and expansion drawers are powered on.
- Check to see if the switch or switches are powered on.
- Check fibre channel cables.

---

## Redistributing logical drives in case of failure

If you select Solaris as the host type when you define the host and host port, Auto Volume Transfer (AVT) is disabled on Solaris hosts. In this case, if a failure occurs that initiates a controller failover, you must manually redistribute logical drives to their preferred paths.

Complete the following steps to manually redistribute logical drives to their preferred paths:

1. Repair or replace any faulty components. For more information, see the Installation, User's and Maintenance Guide for the appropriate DS4000 storage subsystem.
2. Using the Subsystem Management window, redistribute logical drives to their preferred paths by clicking **Advanced** → **Recovery** → **Redistribute Logical Drives**.

See "Steps for defining the host and host port" on page 120 for more information about setting host types.





---

## Chapter 5. Installing and configuring storage management software on POWER-based Linux host systems

You can use DS4000 Storage Manager 10.10 with the following Linux distributions for POWER-based host operating systems:

- SUSE Enterprise Linux Server 9 (SLES 9)
- SUSE Enterprise Linux Server 10 (SLES 10)
- Red Hat Enterprise Linux 4
- Red Hat Enterprise Linux 5 (SMclient only)

**Note:** Before you begin any of the tasks in this chapter, see “Host operating system requirements” for the system requirements that are listed for your Linux distribution. For host I/O attachment to Red Hat Enterprise Linux 5 (storage management only), contact IBM.

This chapter contains the following topics:

- “Before Storage Manager installation: Configuring the host” on page 156
- “Storage Manager installation and configuration” on page 162
- “After Storage Manager installation: Completing the host configuration” on page 175
- “Performing common maintenance tasks” on page 181
- “Remotely installing Linux (SAN boot)” on page 191

For additional Linux on POWER/Series p support, see the following Web sites:

**Linux on POWER resource center**

[www.ibm.com/servers/enable/linux/power/](http://www.ibm.com/servers/enable/linux/power/)

**Linux on Series p support**

[www.ibm.com/servers/eserver/pseries/linux/](http://www.ibm.com/servers/eserver/pseries/linux/)

---

### Host operating system requirements

This section lists the requirements and restrictions for POWER-based Linux host operating systems:

- “SUSE Enterprise Linux Server system requirements”
- “Red Hat Enterprise Linux 4 (RHEL 4) system requirements” on page 153

### SUSE Enterprise Linux Server system requirements

This section lists the minimum hardware and software requirements for a POWER-based host running SLES 9 or SLES 10 attached to a DS4200 Express, DS4300 Turbo, DS4400, DS4500, DS4700, or DS4800 storage subsystem that is managed by DS4000 Storage Manager.

**Important:** See the Storage Manager readme file for Linux on POWER for information about UTM LUN limitations. For steps that will help you find the readme files on the Web, see “Finding the Storage Manager readme files online” on page 24.

### Host hardware requirements

At a minimum, the following hardware is required:

- **Host:** IBM  Series p or POWER server with 64-bit PowerPC<sup>®</sup> architecture<sup>™</sup>
- **Management station for DS4000 Storage Manager**  
You can use the SLES host as the management station for DS4000 Storage Manager.
- For AIX, HP-UX, Solaris, or RHEL management stations, see the minimum requirements listed in the appropriate chapters in this document.

## Software requirements

Check the Storage Manager readme file for Linux on POWER for the latest supported versions of each item listed in this section.

**Note:** See “Finding the Storage Manager readme files online” on page 24 for steps that will help you find the readme files on the Web.

### SUSE Linux Enterprise Server 10

- **Version:** SLES 10.1
- **Kernel:** 2.6.16.46-0.12-ppc64

#### QLogic driver

**Version:** 8.01.07-k3

#### Emulex driver

**Version:** 8.1.10.9

### SUSE Linux Enterprise Server 9

- **Version:** SP3
- **Kernel:** 2.6.5-7.xx-pseries64

#### Emulex driver

**Version:** 8.0.16.27

#### Emulex Application Kit

**Version:** elxlinuxapps-3.0a14-8.0.16.27-1-1

#### QLogic drivers

- **QLogic device driver version:** 8.01.06
- **QLogic device driver (for BladeCenter<sup>®</sup> only), version:** 8.01.06 or later

#### IBM Storage Manager RDAC MPP driver

- rdac-LINUX-09.02.B5.yy-source.tar.gz for SLES 9 and RHEL 4
- rdac-LINUX-09.02.C5.xx-source.tar.gz for SLES 10.1

#### IBM Storage Manager software packages

SMIA-LINUXPPC-10.10.A5.xx.bin

The following individual software packages are included in the SMIA package. You can install them with the SMIA package, or they can be installed individually:

- SMruntime-LINUX-10.10.A5.01.ppc64.rpm
- SMclient-LINUX-10.10.G5.00-1.noarch.rpm
- SMutil-LINUX-10.00.A5.xx-1.ppc64.rpm
- SMagent-LINUX-10.00.A5.xx-1.ppc64.rpm
- SMesm-LINUX-10.10.G5.xx-1.noarch.rpm

## Red Hat Enterprise Linux 4 (RHEL 4) system requirements

This section lists the minimum hardware and software requirements for a POWER-based host running RHEL 4 on a DS4300 Turbo, DS4400, DS4500, DS4700 or DS4800 storage subsystem that is managed by DS4000 Storage Manager.

### Host hardware requirements

The following hardware is required at minimum:

**Host:** IBM @server Series p or POWER server with 64-bit PowerPC architecture.

### Software requirements

Check the Storage Manager readme file for Linux on POWER for the latest supported versions of each item listed in this section.

**Note:** See “Finding the Storage Manager readme files online” on page 24 for steps that will help you find the readme files on the Web.

### Red Hat Enterprise Linux

- Version 4.5
- Kernel 2.6.9-55.EL

### Emulex HBA driver and application kit

- **Emulex driver:** 8.0.16.27 or later
- **Emulex Application Kit:** elxlinuxapps-3.0a14-8.0.16.27-1-1

### QLogic device driver (for BladeCenter only)

Version 8.01.06 or later

### IBM Storage Manager RDAC MPP driver

rdac-LINUX-09.01.B5.xx-source.tar.gz

### IBM Storage Manager software packages

SMIA-LINUXPPC-10.10.A5.xx.bin

The following individual software packages are included in the SMIA package. You can install them with the SMIA package, or separately:

- SMruntime-LINUX-10.10.A5.01.ppc64.rpm
- SMclient-LINUX-10.10.G5.00-1.noarch.rpm
- SMutil-LINUX-10.00.A5.xx-1.ppc64.rpm
- SMagent-LINUX-10.00.A5.xx-1.ppc64.rpm
- SMesm-LINUX-10.10.G5.xx-1.noarch.rpm

**Note:** Updated readme files contain important configuration information that supersede this document. To access the most recent DS4000 Storage Manager readme file for Linux on POWER, see “Finding the Storage Manager readme files online” on page 24.

---

## Linux host restrictions

Before you begin working with DS4000 Storage Manager, read the following list of restrictions. These restrictions apply to both SLES and RHEL operating systems, except as otherwise noted.

**Important:** See the Storage Manager readme file for Linux on POWER for up-to-date restrictions and limitations on supported configurations. For

steps for finding the readme files on the Web, see “Finding the Storage Manager readme files online” on page 24.

### **SAN and connectivity restrictions**

- Dual-path configurations are supported only with the IBM RDAC failover driver.
- Linux on POWER-based hosts can support the following number of host bus adapters (HBAs):
  - **Single-path:** Single-path configurations can support up to two HBAs per controller. You can configure one HBA to each miniHUB on the DS4000 controller. Each HBA-to-controller relationship must reside in a separate zone and a separate partition.
  - **Dual-path (RDAC):** Dual-path configurations can support two HBAs per partition, and one partition per host, per DS4000 storage subsystem.
- Direct-attached single-path configurations are restricted to single-initiator configurations only. You can only make one connection to each minihub on a DS4000 storage subsystem.

**Note:** DS4100, DS4200 Express, DS4300 Turbo, DS4700, and DS4800 storage subsystems do not have minihubs.

- Single-switch configurations are allowed, but each HBA and DS4000 controller combination must be in a separate SAN zone.
- Other storage devices, such as tape devices or other disk storage, must be connected through separate HBAs and SAN zones.
- Clustering is not currently supported.

**Note:** For more information about zoning and enabling zones, see Appendix F, “Connecting HBAs in a FC switch environment,” on page 245.

### **Linux RDAC restrictions (AVT/ADT)**

- This Linux RDAC release does not support auto-volume transfer/auto-disk transfer (AVT/ADT) mode. AVT/ADT is automatically enabled in the Linux storage partitioning host type. Use the Linux host type for Linux partitions, and run the AVT disable script to disable AVT/ADT.

### **Partitioning restrictions**

- Dual-path configurations are supported only with the IBM RDAC failover driver.
- The maximum number of partitions per POWER-based Linux host, per DS4000 storage subsystem, is as follows:
  - **Without RDAC:** Four partitions
  - **With RDAC:** One partition
- Map the host type as follows:
  - **Without RDAC:** All logical drives in single-path configurations must be mapped as host type Linux (AVT is enabled in this host type).
  - **With RDAC:** All logical drives in dual-path configurations must be mapped as host type Linux with AVT disabled, using the AVT disable script.

**Important:** See the Storage Manager readme file for Linux on POWER for up-to-date information about using AVT/ADT. To find the readme files on the Web, see “Finding the Storage Manager readme files online” on page 24.

- On each partition, you must map a LUN 0.
- On each controller, you must configure at least one partition with an LUN between 0 and 31 that is not a UTM or access logical drive.

---

## Direct-attached and SAN-attached configurations

POWER-based Linux hosts support DS4000 storage subsystems in direct-attached and SAN-attached configurations.

### Creating a direct-attached configuration

The following types of direct-attached configurations are supported:

- One to four POWER-based Linux host servers, in single-path configurations, can be connected to each DS4000 storage subsystem.
- One or two POWER-based Linux servers, in dual-path RDAC configurations, can be connected to each DS4000 storage subsystem. Each server must have exactly one HBA connected to each controller port.
- Single and dual HBA configurations are supported.

**Note:** Two-server, dual-path DS4400 or DS4500 configurations require four host-side minihubs, each with exactly one fibre channel connection from each HBA to a minihub.

Complete the following steps to set up a direct-attached configuration:

1. Ensure that no external hubs are being used.
2. Connect the HBAs to each controller or minihub port of the DS4000 storage subsystem.
3. Configure and verify the configuration.

### Creating a SAN-attached configuration

**Before you begin:** To create a SAN-attached configuration, you must ensure that:

- Multiple fibre channel HBAs within the same server must not be able to discover the same DS4000 controller port.
- The IBM Fibre Channel HBAs in a host system must be isolated from each other if they are connected to the same switch that is connected to the same DS4000 controller port.
- An RDAC configuration requires two HBAs or two ports on a single HBA per host system, each port must be in a separate fabric, or zone, that is connected to one of the two controllers.
- Each fibre channel HBA on each host, and controller port on each DS4000 subsystem, must be in its own fabric zone, if they are connecting through a single fibre channel switch.

**Note:** Single HBA configurations are allowed. If you have a single HBA in a SAN-attached configuration, the controller must be fibre channel connected to the HBA through a switch.

**Attention:** Having a single HBA configuration can lead to loss of access data in the event of a path failure.

Complete the following steps to set up a SAN-attached configuration:

1. Connect the HBAs to the switch or switches.
2. Connect the DS4000 storage subsystems to the switch or switches.
3. Set the required zones on the fibre channel switch or switches, if applicable.
4. Configure, then verify the configuration by logging into the switch to view the system.

**Important:** See the Storage Manager readme file for Linux on POWER for up-to-date information about supported configurations. For steps for finding the readme files on the Web, see “Finding the Storage Manager readme files online” on page 24.

**Note:** For more information about zoning and enabling zones, see Appendix F, “Connecting HBAs in a FC switch environment,” on page 245.

---

## Before Storage Manager installation: Configuring the host

Before you install the Storage Manager software, complete the procedures that are described in this section to configure your Linux host for the DS4000 storage subsystem.

**Best practice:** When you boot the host in preparation for installation of the Storage Manager software packages, IBM recommends that you ensure that DS4000 devices are not yet attached to the host system. Attaching DS4000 devices before you configure the host increases system boot time, and can complicate the installation process. Attach the DS4000 devices after you complete the steps in this section, and before you install the Storage Manager software.

## Configuring the SLES host

After you install SLES on your host, and before you begin to install the Storage Manager software and configure your subsystems, complete the steps in this section, as needed.

**Note:** The correct HBA driver is not always included in the Linux kernel. You may need to download the correct version of the HBA and application packages.

### Downloading the Series p HBA driver utility packages

The type of HBA driver that you need depends on your configuration:

- **For a BladeCenter configuration:** Complete the steps described in “Downloading the QLogic HBA driver (for BladeCenter servers only)” on page 158.
- **For all other SLES configurations:** Complete the steps described in the next section, “Downloading the Emulex driver/utility packages.”

**Downloading the Emulex driver/utility packages:** Check the DS4000 Storage Manager readme file for Linux on POWER for the latest supported versions of the following packages. For steps for finding the readme files on the Web, see “Finding the Storage Manager readme files online” on page 24.

#### Application package

Monitors HBAs and facilitates downloading of HBA firmware

#### Driver package

Compiles changes in the configuration file (/etc/lpfc.conf)

## Release notes

Instructions for upgrading the device driver

Then, download the packages from the Emulex Web site, if needed:<http://www.emulex.com/ibm/support/index.jsp>

**Note:** You can use the **lputil** utility to check current HBA firmware levels or to download firmware.

*Installing the lpfc driver:* If you want to install the lpfc driver, complete the following steps to install it now.

1. Create a directory for the lpfc driver package.
2. Download the appropriate driver package to the directory that you just created.
3. Uncompress the file by typing the following command:

```
# tar -zxvf package_name.tgz
```

4. The following is the recommended procedure to update physical HBA driver.
  - a. Get the latest HBA drivers supported by MPP.
  - b. Install the drivers, using the package installation instructions.
  - c. After the driver is installed, change back to the initial Linux RDAC installation directory, and reinstall the RDAC driver using the following commands:

```
# make clean  
# make uninstall  
# make  
# make install
```

5. Reboot the server.

*Installing the optional lpfc application kit:* If you want to install the optional lpfc application kit, complete the following steps to install it now.

1. Create a directory for the lpfcdfc driver package.
2. Download the appropriate driver package to the directory that you just created.
3. Uncompress the file by typing the following command:

```
# tar -zxvf package_name.tgz
```

4. In the directory, find the readme.txt file, and follow the instructions for installing the driver package.

**Note:** If the RDAC driver is already installed, you will need to unload the mppVhba and mppUpper modules before proceeding with the upgrade. See the readme file in the appropriate linuxrdac directory for more information. For example,

```
rmmod mppVhba  
rmmod lpfcdfc  
# or lpfcdfc then lpfc if the HBA  
# application package is installed  
rmmod mppUpper
```

5. After the driver is installed, change back to the initial Linux RDAC installation directory and reinstall the RDAC driver using the following commands:

```
# make clean
# make uninstall
# make
# make install
```

6. Reboot the server.

**Downloading the QLogic HBA driver (for BladeCenter servers only):** Complete the following steps to install the HBA driver for BladeCenter servers, if necessary.

**Note:** In most cases, the driver is included in the Linux distribution.

1. Check the DS4000 Storage Manager readme file for Linux on POWER for the latest supported version of the following package. (For steps for finding the readme files on the Web, see “Finding the Storage Manager readme files online” on page 24.)

**qla2xxx-v8.01.xx-dist.tgz**

2. Direct your Internet browser to the following IBM Web page:  
[www.ibm.com/servers/storage/support/disk/](http://www.ibm.com/servers/storage/support/disk/)
  - a. From the “Support for disk systems” page, click on the link for your specific storage device.
  - b. On the next page, select the Download tab.
  - c. Under “Fixes and drivers,” click on “Storage Manager, firmware, HBA and tools (including readmes).”
  - d. Select the HBA tab.
  - e. Locate the driver for your specific HBA, and click on the link under the column entitled, **Current version and readmes**.
3. Download the driver into a directory on your system.
4. Uncompress the file.
5. The uncompressed QLogic files include a readme. Follow the installation procedures in the readme file to install the HBA driver and utilities.

**Note:** If the RDAC driver is already installed, you will need to unload the mppVhba and mppUpper modules before proceeding with the upgrade. See the readme file in the appropriate linuxrdac directory for more information. For example,

```
rmmod mppVhba
rmmod qla2300
# then
qla2xxx
rmmod mppUpper
```

6. After the driver is installed, change back to the initial Linux RDAC installation directory and reinstall the RDAC driver using the following commands:

```
# make clean
# make uninstall
# make
# make install
```

7. Reboot the server.



## Modifying the configuration file

Add the following options to the appropriate configuration file, if they are not already there.

**Note:** Later versions of the RDAC driver automatically add the required or preferred configuration options to the `initrd` on installation. These options, and any still listed in the `modprobe` configuration file, will be configured on reboot, with preference given to the options in the `modprobe` configuration file, if there are duplicate option values listed. For example, the RDAC recommended value for the `lpfc_nodev_tmo` is 60 seconds; if the `modprobe` configuration file has the `lpfc_nodev_tmo=60` option value listed, and `mppUpdate` or the RDAC driver is installed after the setting is entered into the `modprobe` configuration file, then on a system reboot, the `lpfc_nodev_tmo` value will be 60 seconds.

```
options lpfc lpfc_nodev_tmo=60 lpfc_lun_queue_depth=xx
```

Explanation of new lines:

- `lpfc_lun_queue_depth=xx` Setting the `queue_depth` attribute to the appropriate value is important for system performance. If you have a large DS4000 configuration with many logical drives and hosts attached, use this setting for high performance. See “Viewing or changing queue depth” on page 184 to learn how and when to adjust the queue depth for your system.
- `lpfc lpfc_nodev_tmo=60` The setting must be 60 for proper error handling on RDAC configurations only. Do not use this setting for single-path configurations. See the Emulex readme file for information about preferred settings for non-RDAC configurations.

QLogic HBA driver options (for BladeCenter servers only)

```
options qla2xxx ql2xfailover=0 ql2xmaxqdepth=xx
```

- `ql2xfailover=0` This setting ensures that the QLogic failover driver is not installed. The IBM RDAC driver is incompatible with any other failover driver. QLogic drivers included with the Linux distribution may not include this option. Refer to the driver documentation to determine that this option is supported.
- `ql2xmaxqdepth=8` Setting the `queue_depth` attribute to the appropriate value is important for system performance. If you have a large DS4000 configuration with many logical drives and hosts attached, use this setting for high performance.

**Warning:** If the HBA options are not manually added to the `modprobe` configuration file, and the HBA modules are manually unloaded, then (`rmmod/modprobe/insmod` commands used) the appropriate options will not be configured unless they are stated on the `modprobe` command line. For example, the QLogic HBA driver needs to be upgraded and the `ql2xfailover=0` option is not in the `/etc/modprobe.conf` file. To upgrade the driver, the `mppVhba` and `mppUpper` modules are unloaded via `rmmod`. The new driver is installed and then all of the modules are reloaded using the `modprobe` command. The QLogic driver that is actually loaded is the failover driver, which is not supported with RDAC.

## Recording the HBA worldwide port names

During the installation process, you need to know the HBA worldwide port names. Complete the following steps to view and record the HBA WWPNs:

1. Type the following command to view the HBAs:

```
# ls /proc/scsi/lpfc
```

**Result:** A list displays that contains assigned numbers for all of the HBAs discovered on the system.

2. In the list, identify the host number of the HBA that is connected to the DS4000, and go to that directory by typing the following command:

```
# cd /sys/class/scsi_host/host#
```

where # is the assigned HBA number that you found in step 1 on page 159.

3. Type the following command to view the WWPN of the HBA, and connected DS4000 controllers:

```
# cat port_name
```

where *port\_name* is the assigned HBA number.

Note that the *port\_name* value is equivalent to the WWPN.

**Note:** For additional methods of getting the WWPN information for an HBA, refer to vendor-specific documentation for your Linux distribution.

**Recording the WWPNs for Blades only:** Complete the following steps to view and record the Qlogic WWPNs:

1. Type the following command:

```
# ls /proc/scsi/qla2*
```

**Result:** A list displays that contains assigned numbers for each HBA discovered on the system.

2. For each HBA, type the following command:

```
# cat /proc/scsi/qla2300/x
```

where x is the assigned HBA number that you found in the previous step.

**Result:** You see the following display:

```
scsi-qla#-adapter-port-xxxxxxxxxxxxxx
```

The adapter port value, xxxxxxxxxxxxxxxx, is the WWPN.

## Configuring the RHEL 4 host

After you install RHEL 4 on your host, and before you begin to install the Storage Manager software and configure your subsystems, complete the steps in this section.

### Downloading the RHEL 4 Series p HBA driver utility packages

The type of HBA driver that you need depends on your configuration:

- **For a BladeCenter configuration:** Complete the steps described in “Downloading the QLogic HBA driver (for BladeCenter servers only)” on page 161.
- **For all other RHEL 4 configurations:** Complete the steps described in the next section, “Downloading the Emulex HBA driver utility packages.”

**Downloading the Emulex HBA driver utility packages:** Download the following packages from the Emulex Web site:

<http://www.emulex.com/ibm/support/index.jsp>

Utility package	Compressed package filenames
Emulex device driver	See the DS4000 Storage Manager readme file for Linux on POWER for the latest supported versions. For steps for finding the readme files on the Web, see “Finding the Storage Manager readme files online” on page 24.
Emulex Application Kit	

**Note:** You need the **lputil** utility, which is included in the Emulex Application Kit, to check current HBA firmware levels or to download firmware.

*Installing the lpfc application kit on the RHEL 4 host:* Complete the following steps to install lpfc application kit:

1. Create a directory for the lpfc application kit.
2. Download the application kit package file to the directory you just created.
3. Uncompress the file by typing the following command:

```
# tar -zxvf package_name.tgz
```

4. In the directory, find the readme.txt file, and follow the instructions for installing the application kit.

**Downloading the QLogic HBA driver (for BladeCenter servers only):** Complete the following steps to install the HBA driver for BladeCenter servers:

1. Check the DS4000 Storage Manager readme file for Linux on POWER for the latest supported version of the following package. (For steps for finding the readme files on the Web, see “Finding the Storage Manager readme files online” on page 24.)

#### **qla2xxx-v8.01.xx-dist.tgz**

2. Direct your Internet browser to the following IBM Web page:  
[www.ibm.com/servers/storage/support/disk/](http://www.ibm.com/servers/storage/support/disk/)
  - a. From the “Support for disk systems” page, click on the link for your specific storage device.
  - b. On the next page, select the Download tab.
  - c. Under “Fixes and drivers,” click on “Storage Manager, firmware, HBA and tools (including readmes).”
  - d. Select the HBA tab.
  - e. Locate the driver for your specific HBA, and click on the link under the column entitled, **Current version and readmes**.
3. Download the driver into a directory on your system.
4. Uncompress the file.
5. The uncompressed QLogic files include a readme. Follow the installation procedures in the readme file to install the HBA driver and utilities.

### **Modifying the configuration file**

Add the following lines to the configuration file, if they are not already there.

```
options lpfc lpfc_nodev_tmo=60 lpfc_lun_queue_depth=xx
```

**Note:** Later versions of the lpfc and RDAC drivers automatically add the required or preferred configuration options on installation.

Explanation of new lines:

- `lpfc_lun_queue_depth=xx`—Setting the `queue_depth` attribute to the appropriate value is important for system performance. If you have a large DS4000 configuration with many logical drives and hosts attached, use this setting for high performance. See “Viewing or changing queue depth” on page 184 to learn how and when to adjust the queue depth for your system.
- `lpfc lpfc_nodev_tmo=60`—The setting must be set to 60 for proper error handling on RDAC configurations only. Do not use this setting for single-path configurations. See the Emulex readme file for information about preferred settings for non-RDAC configurations.

## Recording the HBA worldwide port names

During the installation process, you need to know the HBA worldwide port names. Complete the following steps to view and record the HBA WWPNs:

1. Type the following command to view a the HBAs:

```
# ls /proc/scsi/lpfc
```

**Result:** A list displays that contains assigned numbers for all of the HBAs discovered on the system.

2. In the list, identify the host number of the HBA that is connected to the DS4000, and go to that directory by typing the following command:

```
# cd /sys/class/scsi_host/host#
```

where `#` is the assigned HBA number that you found in step 1.

3. Type the following command to view the WWPN of the HBA, and connected DS4000 controllers:

```
cat port_name
```

where `port_name` is the assigned HBA number.

Note that the `port_name` value is equivalent to the WWPN.

**Recording the WWPNs for JS20 Blades only:** Complete the following steps to view and record the Qlogic WWPNs:

1. Type the following command:

```
# ls /proc/scsi/qla2*
```

**Result:** A list displays that contains assigned numbers for each HBA discovered on the system.

2. For each HBA, type the following command:

```
# cat /proc/scsi/qla2300/x
```

where `x` is the assigned HBA number that you found in the previous step.

**Result:** You see the following display:

```
scsi-qla#-adapter-port-xxxxxxxxxxxxxx
```

The adapter port value, `xxxxxxxxxxxxxx`, is the WWPN.

---

## Storage Manager installation and configuration

After you complete the host configuration procedures that are described in “Before Storage Manager installation: Configuring the host” on page 156, you can install and configure Storage Manager following the steps in this section.

**Note:** Before you begin the Storage Manager installation, ensure that the DS4000 devices are attached to the host.

With Storage Manager 10.10, the Storage Manager client software and utilities are available for POWER-based SLES 9, SLES 10, and RHEL 4 hosts.

**Note:** RHEL 5 is supported *only* for SMclient.

- For host I/O attachment to Red Hat Enterprise Linux 5 (storage management only), contact IBM.
- For information about installing DS4000 Storage Manager on an AIX, Solaris, or HP-UX management station, see the appropriate installation chapter in this document:
  - Chapter 4, “Installing and configuring storage management software on Solaris host systems,” on page 107
  - Chapter 5, “Installing and configuring storage management software on POWER-based Linux host systems,” on page 151
  - Chapter 6, “Completing the software configuration,” on page 197
- For information about installing DS4000 Storage Manager on a Windows or i386 processor-based Linux management station, see *IBM System Storage DS4000 Storage Manager Installation and Host Support Guide for Intel-based Operating System Environments*.
- For information about installing DS4000 Storage Manager on a POWER-based RHEL 4 management station, see the appropriate sections in this chapter.

## Requirements

- DS4000 Storage Manager 10.10
- Graphics adapter card or a remote graphical console program (such as VNC or Exceed)
- Graphical Interface X Configuration (such as XFree86) installed and configured on the host
- The DS4000 storage subsystem must be attached to the host

### Opening a remote Xwindows or VNC connection

The Storage Manager SMIA package must be installed in a graphics environment, as indicated in the listed requirements. If the local console does not have a graphics card, you can install the package remotely through VNC or Xwindows connections, as follows:

#### Xwindows connection

Complete the following steps to open a remote Xwindow connection:

1. Ensure that an Xwindows program is installed and running on your server.
2. Open a remote Xwindow from your PC using Exceed by typing the following command line in the Exceed Client Startup window with appropriate other selections:

```
xterm -display PC-IP-ADDR:0 -T remote-IPADDR  
-r -ls +sb -sl 2000 -n remote-IPADDR -geom 80x24+0+0
```

#### VNC connection

Complete the following steps to open a VNC connection:

1. Open the VNC Web browser by typing the following commands:

```
# cd /root
# vncserver
```

2. When you are asked for a password, type a new password and write it down. A message displays a session number, as in the following example:

```
hostIP:1
```

where 1 is the session number.

3. Open a local browser window and enter *<host IP:580 session number>*, as shown in the following example:

```
http://192.168.1.1:5809
```

where the host IP is 192.168.1.1, and the session number is 1.

## Installing DS4000 Storage Manager and utilities

Use the procedures in this section to install DS4000 Storage Manager on your SLES 9, SLES 10, or RHEL 4 host.

You can install all of the DS4000 Storage Manager software packages automatically by using the Storage Manager installation wizard, or you can install each package manually. This section contains the following procedures.

- “Installing Storage Manager using the installation wizard”
- “Installing Storage Manager packages manually” on page 165 (original method)

### Prerequisites

If you are installing SMclient on the host, ensure that the following conditions are met.

- The host on which you are installing SMclient meets the minimum hardware and software requirements described in “Host hardware requirements” on page 153.
- The Graphical Interface X Configuration is installed and configured. If this was not completed at Linux installation, configure it now using one of the following tools:

**SLES 9**            Use xfree86.

**SLES 10**          Use sax2.

**RHEL 4 and 5**    Use redhat-config-xfree86.

- The DS4000 Storage Manager files have been downloaded to a directory on the host.

**Note:** If you do not have the files, you can find them at the following Web site:

[www-1.ibm.com/servers/storage/support/disk/](http://www-1.ibm.com/servers/storage/support/disk/) Click the link for your storage subsystem. When the storage subsystem page opens, click the **Download** tab, and follow the links to the Storage Manager files.

### Installing Storage Manager using the installation wizard

The DS4000 Storage Manager installation wizard is a Java-based interactive method of choosing which packages to automatically install on your host system. The installation wizard installs the following software packages on the host:

- SMruntime
- SMesm
- SMclient
- SMagent
- SMutil

If you are installing Storage Manager 10.10 on Linux on POWER, and your system does not meet the requirements for using the wizard, does not have a graphics card installed, or if for any reason you do not want to use the wizard to install the software, you can perform the installation without a GUI by typing the `sh <installer-package-name.bin> -i console` command in the command line interface. You can also skip this section and install the stand-alone host software packages using the procedures described in “Installing Storage Manager packages manually.” All the packages are included with the installation CD.

**Steps for installing DS4000 Storage Manager software using the installation wizard:** Complete the following steps to install the DS4000 Storage Manager software using the installation wizard. Adjust the steps as necessary for your specific installation.

1. Download the Storage Manager SMIA package file from the DS4000 Storage Manager CD, or from the DS4000 support Web site, to a directory on your system.
2. Open the file on your system by typing the following command:

```
# sh SMIA-LINUXPPC-09.xx.A5.xx.bin
```

The Storage Manager Installation Wizard’s Introduction window opens.

3. Follow the instructions in each window of the wizard. When you select the installation type, you can choose one of the following options:
  - Typical (Full) Installation—Installs all Storage Manager software packages
  - Management Station—Installs SMruntime and SMclient
  - Host—Installs SMruntime, SMagent and SMutil
  - Custom—Allows you to select which packages you want to install

**Result:** The DS4000 Storage Manager software is installed on your system.

### Installing Storage Manager packages manually

Use the following procedures, in the order listed, to install the DS4000 Storage Manager software on a POWER-based Linux storage management station.

Install the Storage Manager software in the following order.

1. “Steps for installing SMruntime software”
2. “Steps for installing SMclient software” on page 166
3. “Steps for installing SMutil” on page 167
4. “Steps for installing SMagent (optional)” on page 167

**Note:** SMclient is dependent on SMruntime, which is a Java compiler for SMclient and must be installed first.

**Steps for installing SMruntime software:** Modify the following commands as needed for your installation. No restart is required during the installation process.

1. Install SMruntime by typing the following command:

```
# rpm -ihv SMruntime-LINUX-10.xx.A5.xx-1.ppc64.rpm
```

2. Verify that the installation was successful by typing the following command:

```
# rpm -qa | grep SMruntime
```

**Steps for installing SMesm software (required if installing SMclient):** Modify the following commands as needed for your installation. No restart is required during the client installation process.

1. Install SMesm by typing the following command:

```
# rpm -ihv SMesm-LINUX-10.xx.G5.xx-1.noarch.rpm
```

2. Verify that the installation was successful by typing the following command:

```
# rpm -qa |grep SMesm
```

**Result:** The verification process shows the package name and version.

After completing the installation of the esm software, you can launch the SMesm on the host by typing the following command:

```
# /opt/IBM_DS4000/SMesm
```

**Result:** The Storage Manager Enterprise Management window opens.

**Note:** If the Enterprise Management window does not open, verify that the Storage Manager software packages listed in the installation procedures completed their installation without error, and that the X Graphical Interface is configured and running on the server.

(The SMesm is a Java-based program that must run in a graphical interface or remote graphical window. See “Opening a remote Xwindows or VNC connection” on page 163.)

If the verification process returns an error, contact your support representative.

**Steps for installing SMclient software:** Modify the following commands as needed for your installation. No restart is required during the client installation process.

1. Install SMclient by typing the following command:

```
# rpm -ihv SMclient-LINUX-10.xx.G5.xx-1.noarch.rpm
```

2. Verify that the installation was successful by typing the following command:

```
# rpm -qa |grep SMclient
```

**Result:** The verification process shows the package name and version.

After completing the installation of the client software, you can launch the SMclient on the host by typing the following command:



```
# /opt/IBM_DS4000/SMclient
```

**Result:** The Storage Manager Enterprise Management window opens.

**Note:** If the Enterprise Management window does not open, verify that the Storage Manager software packages listed in the installation procedures completed their installation without error, and that the X Graphical Interface is configured and running on the server.

(The SMclient is a Java-based program that must run in a graphical interface or remote graphical window. See “Opening a remote Xwindows or VNC connection” on page 163.)

If the verification process returns an error, contact your support representative.

**Steps for installing SMutil:** Modify the commands as needed for your installation. No restart is required during the installation process.

1. Install SMutil by typing the following command:

```
# rpm -ihv SMutil-LINUX-10.xx.A5.xx-1.ppc64.rpm
```

2. Verify that the installation was successful by typing the following command:

```
# rpm -qa |grep SMutil
```

**Result:** The verification process shows the package name and version.

**Steps for installing SMagent (optional):** SMagent is required for in-band management only. It is not required for out-of-band management.

**Note:** SMagent is not supported with DS4000 controller firmware version 05.42.xx.xx.

Modify the commands as needed for your installation. No restart is required during the installation process.

1. Install SMagent by typing the following command:

```
# rpm -ihv SMagent-LINUX-10.xx.A5.xx-1.ppc64.rpm
```

2. Verify that the installation was successful by typing the following command:

```
# rpm -qa |grep SMagent
```

**Result:** The verification process shows the package name and version.

**Note:** If no UTM LUNs are assigned on the DS4000, SMagent stops with a warning message that there are no UTM LUNs available. This is normal. After a UTM LUN is assigned, start the SMagent program by typing SMagent start.

**Starting or stopping SMagent software:** Use the following command to manually start SMagent:

```
# SMagent start
```

Use the following command to manually stop SMagent:

```
# SMagent stop
```

## Configuring storage subsystems using DS4000 Storage Manager

If you have purchased a Storage Partitioning premium feature, ensure that the premium feature is enabled. For more information, see “Enabling premium features” on page 18.

**Note:** Before you configure storage subsystems, be sure to read the following sections in the Introduction chapter:

- “Storage subsystem management methods” on page 8
- “Setting up IP addresses for DS4000 storage controllers” on page 13

This section contains the following topics:

- “Adding storage subsystems to SMclient”
- “Storage Partitioning: Defining a host group” on page 172

### Adding storage subsystems to SMclient

After the disk subsystem is configured on the network, perform the following steps to add storage subsystems to DS4000 SMclient.

#### Notes:

1. If the Enterprise Management window does not open, verify that the Storage Manager software packages listed in the installation procedures completed their installation without error, and that the X Graphical Interface is configured and running on the server.

(The SMclient is a Java-based program that must run in a graphical interface or remote graphical window. See “Opening a remote Xwindows or VNC connection” on page 163.)

If the verification process returns an error, contact your support representative.

2. Storage Manager client software version 10.10 is supported on SLES 9, SLES 10, RHEL 4, and for the SMclient *only*, RHEL 5.
1. Start SMclient on the management station by typing the following command:

```
# /opt/IBM_DS4000/SMclient
```

The Enterprise Management window opens.

2. Complete the following steps to add the storage subsystems to the SMclient:
  - a. In the Enterprise Management window, click **Edit → Add Storage Subsystem**.
  - b. In the Add Storage Subsystem window, type the IP addresses of each controller in the storage subsystem, and click **Add**. The name of the storage subsystem displays in the Enterprise Management window.

**Note:** Failure to add both controllers results in a partially-managed system.

3. Double-click the name of the storage subsystem to open its Subsystem Management window.

### Upgrading controller firmware and NVSRAM

The procedures in this section describe how to download and install DS4000 controller firmware and NVSRAM.

**Note:** If you are upgrading a DS4800, DS4700, or a DS4200 storage subsystem to controller firmware version 07.10.xx.xx, see Appendix D, “Using the IBM System Storage DS4000 Controller Firmware Upgrade Tool,” on page 235. After upgrading to controller firmware version 07.10.xx.xx, use the SMclient for maintenance releases and future code levels.

**Overview:** Read the information in the following sections before you begin the download procedures:

- “Using concurrent download”
- “Upgrading controller firmware and NVSRAM” on page 168
- “Using traditional or staged download”

*Using concurrent download:* Depending on your system’s current firmware version, you might be able to use *concurrent download*. Concurrent download is a method of downloading firmware to the controllers that does not require you to stop I/O to the controllers during the process.

**Note:** Concurrent download is not supported with controller firmware version 06.14.xx.xx and might not be supported on other versions. Check the Storage Manager readme file for Linux on POWER to find out which firmware versions currently support concurrent download.

*Using traditional or staged download:* There are two methods for downloading the firmware to the controllers:

- Traditional download
- Staged download

#### **Traditional download**

The traditional download process takes significantly longer and must be done in one phase, rather than in two phases as with the staged controller firmware download. Therefore the preferred method of controller firmware download is the staged controller firmware download.

#### **Staged download**

With staged firmware download, the download process occurs in two distinct phases: firmware transfer and firmware activation. You can perform the time-consuming task of loading the firmware online so that it is functionally transparent to the application. You can then defer the activation of the loaded firmware to a convenient time.

Some reasons for activating firmware files at a later time include the following:

- **Time of day**—Activating can take a long time, so you might want to wait until I/O loads are lighter because the controllers will go offline briefly to activate the new firmware.
- **Type of package**—You might want to test the new firmware package on one storage subsystem before activating it on other storage subsystems.
- **Multiple controllers**—You can download controller firmware from the storage management software to all storage subsystem controllers for later activation.

#### **Notes:**

1. You cannot use staged download to upgrade DS4000 controller firmware version 05.xx.xx.xx to 06.xx.xx.xx or 6.xx.xx.xx to 07.10.xx.xx. You can only use staged download if the DS4000 controller firmware

version is already 06.xx.xx.xx or higher, and you are downloading another version of 06.xx.xx.xx firmware or higher.

2. Staged controller firmware download is not supported on DS4400 storage subsystems.

**Important:** Do not perform other storage management tasks, such as creating or deleting logical drives, reconstructing arrays, and so on, while downloading the DS4000 storage subsystem controller firmware. It is recommended that you close all storage management sessions (except for the session that you use to upgrade the firmware) to the DS4000 storage subsystem that you plan to update.

**Preparing for firmware or NVSRAM download:** To prepare for download, review and complete all of the steps in this section before you start the download procedures.

**Check current versions of controller firmware and NVSRAM:** Versions of controller firmware and NVSRAM that are provided with this product might be later releases than those described in this document.

To check the controller firmware and NVSRAM versions that are currently installed on your system, complete the following steps:

1. In the Subsystem Management window, click **Storage Subsystem → View Profile**. The Storage Subsystem Profile window displays.
2. In the Storage Subsystem Profile window, click the Controllers tab to view the current versions of controller firmware and NVSRAM.
3. Click **Close** to close the Storage Subsystem Profile window.
4. To find whether the versions of controller firmware and NVSRAM that are currently on your storage subsystem are the latest versions, check the Storage Manager readme file for Linux on POWER online. (See “Finding the Storage Manager readme files online” on page 24 for details.)
5. If you find that you do not have the latest versions of the firmware and NVSRAM, download the correct versions from this Web site to a directory on your system, then follow the preparation and upgrade procedures that are described in this section.

**Save the storage subsystem configuration:** Saving the storage subsystem configuration to a script file is necessary in order to restore the configuration in the event of a catastrophic failure.

**Attention:** Do not use this option if the storage subsystem is undergoing an operation that changes any configuration settings. (If any logical drive listed in the Logical View of the Subsystem Management window has a clock icon, then a configuration change is occurring, and you must wait to save the configuration.)

You can also save the storage subsystem profile by selecting **Storage Subsystem → View Profile** in the Subsystem Management window, and clicking **Save As**. Then, in the Save Profile window, select the sections of the profile that you want to save, specify a name and location for the text file, and click **Save**.

Save the storage subsystem configuration by completing the following steps:

1. In the Subsystem Management window, click **Storage Subsystem → Configuration → Save**. The Save Configuration window displays.
2. In the Save Configuration window, select the elements of the configuration that you want to save, and click **Yes**. A save dialog displays.
3. In the save dialog, specify a name for the script file and select its location.

**Notes:**

- The .cfg extension is used by default for the script file if you do not specify a file extension.
  - Do not store your DS4000 Storage Subsystem configuration script file in the same location as the logical drives that are defined on your DS4000 Storage Subsystem. If you do, and the logical drives fail during the subsequent migration, you will lose data.
4. Click **Save**. The Configuration Saved window displays.
  5. Review the information in the Configuration Saved window, then click **OK** to return to the Subsystem Management window.

*Determine whether you can use concurrent download:* You can use concurrent download only if you are upgrading from one version of controller firmware to a later release of the same version. For example, if you are upgrading from 06.10.xx.xx to 06.12.xx.xx, you can use concurrent download. However, if you are upgrading from 05.xx.xx.xx to 06.1x.xx.xx, you *cannot* use concurrent download, and you need to stop I/O before upgrading controller firmware.

**Notes:**

1. Concurrent download is not supported with controller firmware version 06.14.xx.xx and might not be supported with other firmware versions. See the latest Storage Manager readme file for Linux on POWER to find out which firmware versions currently support concurrent download.
2. You can only use concurrent download if an RDAC driver is installed on the host.
3. Single-controller (SCU) storage subsystem models do not support concurrent download.

*Table 19. Firmware versions that support concurrent download (Linux on POWER)*

<b>DS4000 storage subsystem:</b>	<b>Controller firmware version:</b>
DS4100	06.10.xx.xx, 06.12.xx.xx
DS4200	06.16.88.xx, 06.23.xx.xx, 06.60.xx.xx, 07.10.xx.xx
DS4300 base and Turbo	06.10.xx.xx, 06.12.xx.xx, 06.19.xx.xx, 06.60.xx.xx
DS4400	06.10.xx.xx, 06.12.xx.xx
DS4500	06.10.xx.xx, 06.12.xx.xx, 06.19.xx.xx, 06.60.xx.xx
DS4700	06.16.xx.xx, 06.23.xx.xx, 06.60.xx.xx, 07.10.xx.xx
DS4800	06.16.xx.xx, 06.23.xx.xx, 06.60.xx.xx, 07.10.xx.xx
All other DS4000 storage subsystems	05.30.xx.xx, 06.10.xx.xx, 06.12.xx.xx

**Steps for upgrading the controller firmware:** Complete the following steps to install a new firmware version on the controllers:

1. Download the correct version of the firmware from the Web site that is listed in “Check current versions of controller firmware and NVSRAM” on page 170. Place the file in a designated directory on the host system.

2. Check your system's current firmware versions to determine whether you need to stop I/O, using the information that is listed in "Using concurrent download" on page 169 and in the latest Storage Manager readme file for Linux on POWER. In addition, verify that an RDAC driver is installed on the host.  
**Attention:** If you do not have the correct firmware versions for concurrent download, or if an RDAC driver is not installed, you *must* stop I/O to the controllers before you upgrade the firmware.
3. Ensure that the array is in an Optimal state. If it is not, resolve the issue before continuing to the next step.
4. In the Subsystem Management window, click **Advanced** → **Maintenance** → **Download** → **Controller Firmware**. The Download Firmware window displays.
5. Click **Browse** to select the firmware file that you previously downloaded to a directory on the host.
6. If you want to perform a staged firmware download, select the check box next to "Transfer files but don't activate them (activate later)." If you want to perform a traditional firmware download, do not select the check box, and the firmware will load immediately.
7. Click **Transfer**. The Confirm Download window displays.
8. Click **Yes** to start the download.
9. Verify that the firmware was successfully installed.

**Steps for upgrading the NVSRAM:** Complete the following steps to install a new version of NVSRAM on the controllers. NVSRAM will be activated immediately.

1. Download the correct NVSRAM version from the Web site that is listed in "Check current versions of controller firmware and NVSRAM" on page 170. Place the file in a designated directory on the host system.
2. Stop I/O.
3. Ensure that the array is in an Optimal state. If it is not, resolve the issue before continuing to the next step.
4. In the Subsystem Management window, click **Advanced** → **Maintenance** → **Download** → **Controller NVSRAM**. The Download NVSRAM window displays.
5. Click **Browse** to select the NVSRAM file that you previously downloaded to a directory on the host.
6. Click **Transfer**. The Confirm Download window displays.
7. Click **Yes** to start the download.
8. Verify that the NVSRAM was successfully installed. If using Linux host profile, run the AVT disable script, again, to disable AVT.
9. Start I/O.

### **Storage Partitioning: Defining a host group**

A *host group* is an entity in the Storage Partitioning topology that defines a logical collection of host computers that require shared access to one or more logical drives. You can grant individual hosts in a defined host group access to storage partitions, independently of the host group. You can make logical drive-to-LUN mappings to the host group or to an individual host in a host group.

If you have purchased a Storage Partitioning premium feature, ensure that the premium feature is enabled.

**Steps for defining a host group, host, and host ports:** Complete the following steps to define a host group.

**Before you begin:** Note the following information.

- If your subsystem is running controller firmware 06.1x.xx.xx or higher, after you define your host group you can use the Storage Partitioning wizard feature of the Storage Manager task assistant to define hosts, host ports, and storage partitions.
- Create the host group at the storage subsystem level. Do not create host groups at the default group level.

**Exception:** If you are running a DS4000 configuration without partitioning enabled, you can use the default host group.

- If using Linux host profile, run the AVT disable script, again, to disable AVT.

**Important::** See the Storage Manager readme file for Linux on POWER for up-to-date information about using AVT/ADT. For steps to find the readme files on the Web, see “Finding the Storage Manager readme files online” on page 24.

1. Click the **Mappings View** tab on the Subsystem Management window.
2. In the Topology section of the Mappings window, highlight the name of the storage subsystem, and click **Mappings** → **Define** → **Host Group**.

**Note:** Make sure that the storage subsystem is highlighted in the left panel of the Subsystem Management window. Do not highlight Undefined Mappings.

3. Type the name of the new host group (for example, RHEL 4). Click **Add**, and then click **Close**.
4. Highlight the new host group and click **Mappings** → **Define** → **Host**.
5. Type the name of the host to which the storage subsystem is attached (for example, redhatserver). Click **Add**, and then click **Close**.
6. Highlight the host that you just added, then right-click and select **Define Host Port**.
7. Select the first HBA’s host port identifier (for example, 10:00:00:00:c9:24:0c:3f.). If you do not see the identifier that you are looking for, see the “Important” note at the end of this procedure.
8. Change the host type, as follows, according to your configuration:
  - **Single-path:** Select **Linux**.
  - **Dual-path (RDAC):** Dual-path (RDAC): select Linux host profile and run the AVT disable script to disable AVT.

**Important::** See the Storage Manager readme file for Linux on POWER for up-to-date information about using AVT/ADT. For steps for finding the readme files on the Web, see “Finding the Storage Manager readme files online” on page 24.

Click **Add**.

**Important::** Failure to change the host type from the default might cause undesired results.

9. If you are configuring an additional HBA to this partition, choose the host port for the next HBA and click **Add**, and then click **Close**.

**Note:** You must configure two HBAs per partition if you are using RDAC.

**Recommendation::** Before closing the window, record the name of each host port along with the WWPN of its corresponding HBA, and save the information to a file for future reference.

10. Verify that the WWPN matches the Host Port Identifier number assigned to the host port in the host partition table of the DS4000 SMclient.
11. Repeat this procedure to verify the second host port, if configuring for RDAC.

**Important::** The host port identifier is the worldwide port name (WWPN) of the host bus adapter. If you do not see the one you want in the host port identifier drop down menu, check the following:

**Fibre channel cable**

You might not be using the correct cable. Verify that you are using the correct fibre channel cable, and that it is connected properly.

**Switch zoning**

If you are connected to a switch, ensure that it is zoned correctly.

**Note:** For more information about zoning and enabling zones, see Appendix F, “Connecting HBAs in a FC switch environment,” on page 245.

**lpfc module**

You might not have initialized the lpfc module (verify with the **lsmmod** command). Load the appropriate module by typing **modprobe lpfc** or **modprobe lpfcdfc** for the subsystem that does not display in the menu.

## Mapping LUNs to a storage partition

This section contains the following procedures:

- “Mapping LUNs to a new partition”
- “Adding LUNs to an existing partition” on page 175

**Important:**

1. It is recommended that you always map the LUNs using consecutive numbers, starting with LUN 0. For example, map LUNs to numbers 0; 1; 2; 3; 4; 5; and so on, without skipping any numbers. (For RHEL 4 hosts, this is *required*.)
2. It is recommended that you do not map at the host group level. If you do, every attached host can see all the LUNs.
3. On each partition, you must map a LUN 0. (It is recommended that LUN 0 is not a UTM LUN.)
4. You must map at least one non-UTM LUN on each partition.

**Mapping LUNs to a new partition:** When mapping LUNs for the first time to a newly-created partition, complete the following steps to map LUNs to the partition.

**Before you begin:** Read “DS4000 Storage Manager performance planning” on page 14 for information about planning the number of LUNs to map to each partition.

**Important::** If your subsystem is running controller firmware 06.1x.xx.xx or higher, you can use the Storage Partitioning wizard feature of the Storage Manager task assistant, instead of this procedure, to map LUNs to a new storage partition.



1. Select the Mappings view of the Subsystem Management window.
2. In the Topology section, right-click the host on which you want to map LUNs, and select **Define Storage Partitioning**. The Define Storage Partitioning window opens.
3. In the Define Storage Partitioning window, select **Host**, then click **Next**.
4. Select the logical drive by name, on the right side of the window.
5. Accept the default LUN ID, or change it, then click **Add**.
6. Repeat step 5 for each LUN that you want to map to the partition.

**Adding LUNs to an existing partition:** When adding LUNs to an existing partition, complete the following steps to map the new LUNs to the partition.

**Before you begin:** Read “DS4000 Storage Manager performance planning” on page 14 for information about planning the number of LUNs to map to each partition.

1. Select the Mappings view of the Subsystem Management window.
2. In the Topology section, right-click the host on which you want to map LUNs, and select **Define Additional Mappings**. The Define Additional Mapping window opens.
3. In the Define Additional Mapping window, select the following options, and then click **Add**:
  - Host group or host
  - Logical unit number (LUN)(0-255)
  - Logical drive

Repeat these steps for each LUN that you want to add to the partition.

## Failover drivers

A Linux on POWER host system requires either the RHEL or the SLES Redundant Disk Array Controller (RDAC) failover driver for fibre channel path redundancy.

The failover driver monitors I/O paths. If a component failure occurs in one of the fibre channel paths, the failover driver reroutes all I/O to another path.

---

## After Storage Manager installation: Completing the host configuration

After you install the Storage Manager software, complete the host configuration procedures that are described in this section.

### Installing the RDAC Multipath driver

This section describes how to install the RDAC driver for a dual-path POWER-based Linux configuration.

**Important::** Before you install RDAC, make sure that the partitions and LUNs are configured and assigned and that the correct HBA driver is installed.

Complete the following steps to install RDAC:

1. Download the RDAC driver package from the IBM DS4000 support Web site.

**RDAC package for SLES 9, SLES 10, and RHEL 4:**

`rdac_LINUX_09.01.B5.xx_source_tar_gz`

2. Create a directory on the host and download the RDAC driver package to that directory.
3. Uncompress the file by typing the following command:

```
# tar -zxvf rdac-LINUX-package_version-source.tar.gz
```

where *package\_version* is the SLES 9, SLES 10, or RHEL 4 package version number that is specified in step 1 on page 175.

**Result:** A directory called **linuxrdac-*version*#** (SLES 9, SLES 10, and RHEL 4) or **linuxrdac** (RHEL 4) is created.

4. Open the Readme.txt that is included in the *linuxrdac-*version*#* directory.
5. In the Readme.txt, find the instructions for building and installing the driver and complete the steps, which include rebooting the server.

**Note:** Make sure you reboot the server before you proceed to step 6.

6. Type the following command to list the installed modules:

```
# lsmod
```

7. Verify that module entries are included in the **lsmod** list, as follows:

**Module entries for SLES 9, SLES 10, and RHEL 4:**

- mppVhba
- mppUpper
- lpfc (or qla2xxx for BladeCenter configurations)
- lpfcdfc (if ioctl module is installed)

**Note:** If you do not see the *mpp\_Vhba* module, the likely cause is that the server was rebooted before the LUNs were assigned, so the *mpp\_Vhba* module was not installed. If this is the case, assign the LUNs now, reboot the server, and then repeat step 7.

8. Type the following command to verify the driver version:

```
# mppUtil -V
```

**Result:** The Linux multipath driver version displays.

9. Type the following command to verify that devices are configured with the RDAC driver

```
# ls -lR /proc/mpp
```

**Result:** An output similar to the following example displays:

```

# ls -lR /proc/mpp
/proc/mpp:
total 0
dr-xr-xr-x  4 root  root          0 Oct 24 02:56 DS4100-sys1
crwxrwxrwx  1 root  root      254,  0 Oct 24 02:56 mppVBusNode

/proc/mpp/ DS4100-sys1:
total 0
dr-xr-xr-x  3 root  root          0 Oct 24 02:56 controllerA
dr-xr-xr-x  3 root  root          0 Oct 24 02:56 controllerB
-rw-r--r--  1 root  root          0 Oct 24 02:56 virtualLun0
-rw-r--r--  1 root  root          0 Oct 24 02:56 virtualLun1
-rw-r--r--  1 root  root          0 Oct 24 02:56 virtualLun2
-rw-r--r--  1 root  root          0 Oct 24 02:56 virtualLun3
-rw-r--r--  1 root  root          0 Oct 24 02:56 virtualLun4
-rw-r--r--  1 root  root          0 Oct 24 02:56 virtualLun5

/proc/mpp/ DS4100-sys1/controllerA:
total 0
dr-xr-xr-x  2 root  root          0 Oct 24 02:56 lpfc_h6c0t2

/proc/mpp/ DS4100-sys1/controllerA/lpfc_h6c0t2:
total 0
-rw-r--r--  1 root  root          0 Oct 24 02:56 LUN0
-rw-r--r--  1 root  root          0 Oct 24 02:56 LUN1
-rw-r--r--  1 root  root          0 Oct 24 02:56 LUN2
-rw-r--r--  1 root  root          0 Oct 24 02:56 LUN3
-rw-r--r--  1 root  root          0 Oct 24 02:56 LUN4
-rw-r--r--  1 root  root          0 Oct 24 02:56 LUN5

/proc/mpp/ DS4100-sys1/controllerB:
total 0
dr-xr-xr-x  2 root  root          0 Oct 24 02:56 lpfc_h5c0t0

/proc/mpp/ DS4100-sys1/controllerB/lpfc_h5c0t0:
total 0
-rw-r--r--  1 root  root          0 Oct 24 02:56 LUN0
-rw-r--r--  1 root  root          0 Oct 24 02:56 LUN1
-rw-r--r--  1 root  root          0 Oct 24 02:56 LUN2
-rw-r--r--  1 root  root          0 Oct 24 02:56 LUN3
-rw-r--r--  1 root  root          0 Oct 24 02:56 LUN4
-rw-r--r--  1 root  root          0 Oct 24 02:56 LUN5

```

**Note:** After you install the RDAC driver, the following commands and man pages are available:

- mppUtil
- mppBusRescan
- mppUpdate
- RDAC

## Performing initial device identification

The initial device identification procedures in this section apply to all distributions: SLES 9, SLES 10, and RHEL 4. Exceptions are noted.

Complete the steps in this section, in the order they are listed:

1. “Probing the scsi bus” on page 178
2. “Associating each HBA WWPN with its assigned host port” on page 178
3. “Viewing the LUNs” on page 179

4. “Associating the system LUN devices with DS4000 LUNs” on page 180

### Probing the scsi bus

Probe the scsi bus by completing one of the following procedures, according to whether RDAC is installed on your system.

- **With RDAC installed:**

Type the following command:

```
# mppBusRescan
```

- **Without RDAC installed:**

You need to remove modules and reload them. Type the following commands to remove the modules:

```
# rmmmod hba_device_driver
```

Type the following commands to reload the modules:

```
# modprobe hba_device_driver
```

### Associating each HBA WWPN with its assigned host port

Associate each HBA WWPN with its assigned host port by completing the following steps:

1. Type the following commands:

```
#cd /sys/class/fc_host/host#  
#ls
```

A list of HBAs is displayed, as shown in the following example:

```
. .. 10 11 7 8 9
```

2. For each HBA in the directory, type the following command:

```
#cat cat port_name  
#cat node_name
```

where *hba#* is an HBA in the directory. The HBA's properties display, as shown in the following example:

```
hostname:/ # cat /proc/scsi/lpfc/10  
Emulex LightPulse FC SCSI 2.10h  
HBA: Emulex LightPulse LP9802 (2 Gigabit) on PCI bus 01 device 08 irq 179  
SerialNum: 1E402065E2  
Firmware Version: 1.90 (H2D1.90X2)  
Hdw: 2003806d  
VendorId: 0xf98010df  
Portname: 10:00:00:00:c9:3b:5c:7b   Nodename: 20:00:00:00:c9:3b:5c:7b  
  
Link Up - Ready:  
  PortID 0x1  
  Private Loop  
  Current speed 2G  
  
lpfc0t00 DID 0000dc WWPN 20:35:00:a0:b8:11:15:a6 WWNN 20:04:00:a0:b8:11:15:a6
```

**Note:** This display is representative of Linux 2.4 kernels. For 2.6 kernels, you see only the recognized target WWPNs, as shown in the following example:

```
1pfc0t00 DID 0000dc WWPN 20:35:00:a0:b8:11:15:a6 WWNN 20:04:00:a0:b8:11:15:a6
```

3. Check the output to verify connectivity with the storage controllers. The output in this example shows that one DS4000, with WWPN **DID 0000dc WWPN 20:35:00:a0:b8:11:15:a6**, is attached to the HBA.

## Viewing the LUNs

View the LUNs by typing the following command:

```
# cat/proc/scsi/scsi
```

The LUN properties display, as shown in the following example:

```
Host: scsi10 Channel: 00 Id: 00 Lun: 00
Vendor: IBM      Model: 1815      FASTT  Rev: 0914
Type:  Direct-Access                      ANSI SCSI revision: 03
Host: scsi10 Channel: 00 Id: 00 Lun: 01
Vendor: IBM      Model: 1815      FASTT  Rev: 0914
Type:  Direct-Access                      ANSI SCSI revision: 03
Host: scsi10 Channel: 00 Id: 00 Lun: 02
Vendor: IBM      Model: 1815      FASTT  Rev: 0914
Type:  Direct-Access                      ANSI SCSI revision: 03
.....
Host: scsi12 Channel: 00 Id: 00 Lun: 00
Vendor: IBM      Model: 1815      FASTT  Rev: 0914
Type:  Direct-Access                      ANSI SCSI revision: 03
Host: scsi12 Channel: 00 Id: 00 Lun: 01
Vendor: IBM      Model: 1815      FASTT  Rev: 0914
Type:  Direct-Access                      ANSI SCSI revision: 03
Host: scsi12 Channel: 00 Id: 00 Lun: 02
Vendor: IBM      Model: 1815      FASTT  Rev: 0914
Type:  Direct-Access                      ANSI SCSI revision: 03
....
Host: scsi13 Channel: 00 Id: 00 Lun: 00
Vendor: IBM      Model: VirtualDisk  Rev: 0914
Type:  Direct-Access                      ANSI SCSI revision: 03
Host: scsi13 Channel: 00 Id: 00 Lun: 01
Vendor: IBM      Model: VirtualDisk  Rev: 0914
Type:  Direct-Access                      ANSI SCSI revision: 03
Host: scsi13 Channel: 00 Id: 00 Lun: 02
Vendor: IBM      Model: VirtualDisk  Rev: 0914
Type:  Direct-Access                      ANSI SCSI revision: 03
```

The example shows three LUNs, which are assigned to a partition with two HBAs for dual-path, with RDAC installed.

### Notes:

1. Each LUN is displayed on both of its configured paths. The active, assigned HBAs are numbers 10 and 12.
2. The **VirtualDisk** is RDAC's logical disk. There is one VirtualDisk for each LUN, regardless of number of paths available.
3. If RDAC is installed but you do not see any VirtualDisks in the output, the most likely cause is that the mpp\_Vhba module did not get installed. (This happens if the RDAC driver was installed before any LUNs were configured.) Use the

**lsmod** command to verify whether the `mpp_Vhba` module is installed. If it is missing from the list of modules, make sure that the LUNs are configured, then reboot the host.

**SLES 9 and SLES 10:** On SLES operating systems only, you can use the **lsscsi** command to view LUNs, instead of **cat/proc/scsi/scsi**. The advantage of using **lsscsi** is that the output is easier to read, as follows:

```
# lsscsi
[10:0:0:0] disk IBM 1815 FASTT 0914 -
[10:0:0:1] disk IBM 1815 FASTT 0914 -
[10:0:0:2] disk IBM 1815 FASTT 0914 -
...
[12:0:0:0] disk IBM 1815 FASTT 0914 -
[12:0:0:1] disk IBM 1815 FASTT 0914 -
[12:0:0:2] disk IBM 1815 FASTT 0914 -
...
[13:0:0:0] disk IBM VirtualDisk 0914 /dev/sdb
[13:0:0:1] disk IBM VirtualDisk 0914 /dev/sdc
[13:0:0:2] disk IBM VirtualDisk 0914 /dev/sdd
```

The fourth column shows the DS4000 model type and the sixth column shows the Linux assigned device number. In this example, only the Virtual RDAC devices are assigned a system device name. If RDAC is not installed, however, system device names display for all of the devices listed in the output.

### Associating the system LUN devices with DS4000 LUNs

Type the following command:

```
# SMdevices
```

The device properties display, as shown in the following example:

```
IBM TotalStorage DS4000/FASTT Storage Manager Devices, Version 09.14.A5.00
Built Mon Mar 28 20:52:15 CST 2005
(C) Copyright International Business Machines Corporation, 2003-2005 Licensed Ma
terial - Program Property of IBM. All rights reserved.

/dev/sdb (/dev/sg5) [Storage Subsystem subsystem_name, Logical Drive Raid-1-2C,
LUN 0, Logical Drive ID <600a0b800011162000000f61423cc8ae>, Preferred Path (Contro
ller-A): In Use]
/dev/sdc (/dev/sg6) [Storage Subsystem subsystem_name, Logical Drive Raid-1-3C,
LUN 1, Logical Drive ID <600a0b80001115ae00000828423cc8db>, Preferred Path (Contro
ller-B): In Use]
/dev/sdd (/dev/sg7) [Storage Subsystem subsystem_name, Logical Drive Raid-1-4C,
LUN 2, Logical Drive ID <600a0b800011162000000f67423cc8f6>, Preferred Path (Contro
ller-A): In Use]
```

The example shows the assigned system device numbers that are associated with the DS4000 storage subsystem name, and storage assigned LUN ID, as they are displayed on the DS4000 storage unit.

**SLES 9, SLES 10, and RHEL 4:** On SLES and RHEL 4 operating systems only, you can use the following steps instead of using **SMdevices**:

**Note:** You might want to do this if you do not have **SMutil** installed.

Type the following command from the linuxrdac directory:

```
# lsvdev
```

The following is an example of the lsvdev output:

```
[root@ibm-sys linuxrdac-09.01.B5.34]# ./lsvdev
```

Array Name	Lun	sd device
DS4500-test-sys	0	-> /dev/sdd
DS4500-test-sys	1	-> /dev/sde
DS4500-test-sys	2	-> /dev/sdf
DS4500-test-sys	3	-> /dev/sdg
DS4500-test-sys	4	-> /dev/sdh
DS4500-test-sys	5	-> /dev/sdi
DS4500-test-sys	6	-> /dev/sdj
DS4500-test-sys	7	-> /dev/sdk
DS4500-test-sys	8	-> /dev/sdl
DS4300-test-sys	0	-> /dev/sdad
DS4300-test-sys	1	-> /dev/sdae
DS4300-test-sys	2	-> /dev/sdaf
DS4300-test-sys	3	-> /dev/sdag
DS4300-test-sys	4	-> /dev/sdah
DS4300-test-sys	5	-> /dev/sdai
DS4300-test-sys	6	-> /dev/sdaj

---

## Performing common maintenance tasks

This section describes some common system administration tasks. The procedures in this section apply to all three distributions: SLES 9, SLES 10, and RHEL 4. Exceptions are noted.

- “Checking LUN size”
- “Using dynamic capacity expansion and dynamic volume expansion” on page 182
- “Using the SMdevices utility to find information about LUNs” on page 183
- “Viewing or changing queue depth” on page 184
- “Replacing IBM host bus adapters on a system” on page 186

### Checking LUN size

This procedure is for SLES 9, SLES 10, and RHEL 4 only. Do *not* use this procedure with RHEL 3, which is no longer supported.

Complete the following steps to check the size of a LUN:

1. Type the following commands:

```
#cd /sys/block/sdXX
# cat size
```

where *XX* is the device name. **Result:** A number displays, as in the following example:

```
8388608
```

2. Multiply this number by 512 (bytes) to calculate the size of the LUN, as shown in the following example:

```
8388608 * 512 = 4294967296 (~ 4GB)
```

**Result:** The result of the calculation is the size of the LUN. In the example, the LUN size is approximately 4 GB.

## Using dynamic capacity expansion and dynamic volume expansion

Dynamic volume expansion (DVE) increases the size of a logical drive. In order to perform a DVE, there must be free capacity available on the array. If there is not, you can first perform a dynamic capacity expansion (DCE) to increase the array's capacity by adding drives.

### Performing a dynamic capacity expansion operation

**Before you begin:** You can find more information about this procedure in the Storage Manager online help.

Complete the following steps to increase the capacity on the array by performing a DCE:

1. In the Logical/Physical view of the Subsystem Management window, right-click on an array and select **Add Free Capacity (Drives)**.
2. In the Add Free Capacity (Drives) window, select one or two available drives and click **Add**.

After you have ensured that there is sufficient free capacity within the array, you can perform a DVE operation, as described in the next topic.

### Performing a dynamic volume expansion operation

**Before you begin:** Ensure that there is available free capacity within the array. You can check free capacity availability using DS4000 Storage Manager, in the Logical/Physical view of the Subsystem Management window. If there is not enough free capacity, and extra drives are available, you can add one or more to the array by performing a dynamic capacity expansion (DCE) operation before you perform the DVE operation.

You can find more information about this procedure in the Storage Manager online help.

#### Restrictions:

1. You cannot resize the logical drive while the logical drive group is activated in classic or enhanced concurrent mode.
2. You cannot resize the root logical drive group.
3. Dynamic Volume Expansion is not supported on 2.4 kernels.



Complete the following steps to increase the size of a logical drive by performing a DVE:

1. Stop I/O to the logical drive whose size you want to increase.
2. Unmount the logical drive, if it is mounted.
3. From the Logical/Physical window of the Subsystem Management window, right-click the logical drive and select **Increase Capacity**. The Increase Logical Drive Capacity—Additional Instructions window opens.
4. Read the additional instructions and click **OK**. The Increase Logical Drive Capacity window opens.
5. Type the amount that you want to increase the logical drive, and click **OK**.  
You see a clock icon on every logical drive within the array. You must wait for the process to complete before you can begin any host intervention.

**Tip:** If the storage subsystem is busy, the process might take several hours to complete.

6. On the host, rescan the logical drive by typing the following commands:

```
# cd /sys/block/sdXX/device
# echo 1 > rescan
```

where *XX* is the device name.

7. Check the size of the logical drive using the steps that are described in “Checking LUN size” on page 181.
8. Remount the logical drive.

## Using the SMdevices utility to find information about LUNs

SMutil features an excellent utility, **SMdevices**, which you can use to map the host-assigned device name for each LUN back to its corresponding DS4000 storage subsystem device.

In the **SMdevices** output, you can view the following DS4000 storage subsystem information, as it is shown on SMclient.

**Note:** The examples in the list refer to the sample **SMdevices** output.

- Host assigned name (/dev/sdh)
- DS4000 storage subsystem name (DS4500\_Storage\_Server-A)
- Logical drive name Raid-5-0A
- LUN ID (LUN 4)
- Preferred controller owner, and whether that controller is currently controlling the logical drive

The following example shows a sample **SMdevices** output for the subsystem **DS4500\_Storage\_Server-A**:

```

# SMdevices
IBM FASTT Storage Manager Devices, Version 09.12.A5.00
Built Fri Jan 14 16:42:15 CST 2005
(C) Copyright International Business Machines Corporation,
2004 Licensed Material - Program Property of IBM. All rights reserved.

/dev/sdh (/dev/sg10) [Storage Subsystem DS4500_Storage_Server-A,
Logical Drive Raid-5-0A, LUN 4, Logical Drive ID
<600a0b80000f0fc300000044412e2dbf>, Preferred Path (Controller-A): In Use]
/dev/sdd (/dev/sg6) [Storage Subsystem DS4500_Storage_Server-A,
Logical Drive Raid-5-1A, LUN 0, Logical Drive ID
<600a0b80000f13ec00000016412e2e86>, Preferred Path (Controller-B): In Use]
/dev/sde (/dev/sg7) [Storage Subsystem DS4500_Storage_Server-A,
Logical Drive Raid-0-0A, LUN 1, Logical Drive ID
<600a0b80000f0fc30000003c412e2d59>, Preferred Path (Controller-A): In Use]
/dev/sdf (/dev/sg8) [Storage Subsystem DS4500_Storage_Server-A,
Logical Drive Raid-1-0A, LUN 2, Logical Drive ID
<600a0b80000f0fc30000003e412e2d79>, Preferred Path (Controller-A): In Use]
/dev/sdg (/dev/sg9) [Storage Subsystem DS4500_Storage_Server-A,
Logical Drive Raid-3-0A, LUN 3, Logical Drive ID
<600a0b80000f13ec00000012412e2e4c>, Preferred Path (Controller-A): In Use]

```

## Viewing or changing queue depth

Setting the *queue\_depth* attribute to the appropriate value is important for system performance. If you have a large DS4000 configuration with many logical drives and hosts attached, use this setting for high performance.

This section provides methods for calculating your system's maximum queue depth, which you can use as a guideline to help you determine the best queue depth setting for your configuration.

**Note:** Changing queue depths for firmware version 07.10.xx.xx is *not* required. The default queue depths for the HBAs are allowed without restriction.

### Calculating maximum queue depth

The formula for calculating the maximum queue depth for your system depends on which firmware version is installed on the controller. Use one of the following formulas to calculate the maximum queue depth for your system.

#### Important::

1. The maximum queue depth might not be an optimal setting in all cases. Use the maximum queue depth as a guideline, and adjust the setting as necessary for your specific configuration.
2. In systems with one or more SATA devices attached, you might need to set the queue depth attribute to a lower value than the maximum queue depth.

#### Formula for controller firmware version 07.10.xx.xx

On DS4000 storage systems that are running DS4000 controller firmware version 07.10.xx.xx, use the following formula to determine the maximum queue depth:

For DS4800:  $4096 / (\text{number-of-hosts} * \text{LUNs-per-host})$

For example, a system with four hosts, each with 32 LUNs, would have a maximum queue depth of **32**:

$$4096 / ( 4 * 32 ) = 32$$

For DS4700/DS4200:  $2048 / (\text{number-of-hosts} * \text{LUNs-per-host})$

For example, a system with four hosts, each with 32 LUNs, would have a maximum queue depth of **16**:

$$2048 / ( 4 * 32 ) = 16$$

#### Formula for controller firmware versions 06.xx.xx.xx or 05.4x.xx.xx

On DS4000 storage systems that are running DS4000 controller firmware versions 05.4x.xx.xx, 06.xx.xx.xx, or later, use the following formula to determine the maximum queue depth:

$$2048 / (\text{number-of-hosts} * \text{LUNs-per-host})$$

For example, a system with four hosts, each with 32 LUNs, would have a maximum queue depth of **16**:

$$2048 / ( 4 * 32 ) = 16$$

#### Formula for controller firmware version 05.30.xx.xx

On DS4000 storage systems that are running DS4000 controller firmware version 05.30.xx.xx or earlier, use the following formula to determine the maximum queue depth:

$$512 / (\text{number-of-hosts} * \text{LUNs-per-host} )$$

For example, a system with four hosts, each with 32 LUNs, would have a maximum queue depth of **4**:

$$512 / ( 4 * 32 ) = 4$$

### Viewing the current queue depth

To see the queue depth of each LUN, type the following command:

```
# cat /proc/scsi/sg/{device_hdr,devices}
```

**Note:** If RDAC is installed, the queue depth number that is displayed in the output is not the same as the host setting for queue depth, because the RDAC driver takes two queues for each LUN. For example, in the following sample output, the queue depth of LUNs mapped to host 11 is set to 10; because RDAC is installed, the output shows a queue depth of 8.

```
#cat /proc/scsi/sg/device_hdr devices
host  chan  id  lun  type  opens  qdepth  busy  online
0      0      1   0    5     0      2       0     1
0      0      8   0    0     3      8       0     1
11     0      4   0    0     0      8       0     1
11     0      4   1    0     0      8       0     1
11     0      4   2    0     0      8       0     1
11     0      4   3    0     0      8       0     1
11     0      4   4    0     0      8       0     1
```

### Changing the queue depth

Complete the following steps to change the queue depth:

1. Using the vi editor, open one of the following configuration files for editing, according to your operating system:
  - **SLES 9 and SLES 10:** /etc/modprobe.conf.local
  - **RHEL 4:** /etc/modprobe.conf
2. Add one of the following options parameters to the configuration file, according to your type of HBA:

- **Emulex HBA:** lpfc\_lun\_queue\_depth=xx
- **JS20 BladeCenter HBA:** ql2xmaxqdepth=xx

where xx is the new queue depth value.

3. Set the new queue depth value, as follows:

- **With RDAC installed:** Type the **mppUpdate** command, then reboot the server.
- **Without RDAC installed:** Uninstall the appropriate HBA driver, then reload it.

**Example:** To change the queue depth value to 10 on an RHEL 4 system with an Emulex HBA and a JS20 BladeCenter HBA, you would type the following commands:

```
# vi /etc/modprobe.conf
options lpfc lpfc_lun_queue_depth=10
options qla2xxx ql2xmaxqdepth=10
```

## Replacing IBM host bus adapters on a system

This section provides requirements and procedures for replacing IBM host bus adapters in Series p servers on your SLES 9 SP3 or RHEL 4 host system using PCI Hotplug tools.

**Important::** This procedure is specific for SLES 9 and RHEL 4 host operating systems only. Do not use this procedure with any other operating system.

### Requirements

#### Operating system:

See one of the following sections for operating system requirements:

- “SUSE Enterprise Linux Server system requirements” on page 151
- “Red Hat Enterprise Linux 4 (RHEL 4) system requirements” on page 153

#### PCI Hotplug tools:

Ensure that the following tools are installed in the /usr/sbin directory:

- **lsslot**
- **drslot\_chrp\_pci**

If these tools are not installed, complete the following steps to install them:

1. Ensure that rdist-6.1.5-792.1 and compat-2004.7.1-1.2 are installed from the SLES 9 media.
2. Download the PCI Hotplug Tools rpm files from the following Web site:  
<https://www14.software.ibm.com/webapp/set2/sas/f/lopdiags/suselinux/hmcmanaged/sles10.html>
3. On the Web page, select **SLES 9 Tools**. Download and install the following rpm files:
  - librtas-1.3.1-0.ppc64.rpm
  - rpa-pci-hotplug-1.0-29.ppc64.rpm
4. Type the following command to install each rpm file:

```
# rpm -Uvh <filename>.rpm
```

where <filename> is the name of the rpm file.

### Host bus adapters:

The following host bus adapters are supported with this procedure:

- FC 6228
- FC 6239
- FC 5716
- FC 5758
- FC 5759

**Note:** See the Storage Manager readme file for Linux on POWER for information about additional supported HBAs.

### PCI core:

The PCI core must be loaded on the system. Type the following command to verify:

```
# ls -l /sys/bus/pci/slots
```

If the PCI core is loaded, the output will look similar to the following:

```
e1m17c224:/usr/sbin # ls -l /sys/bus/pci/slots
total 0
drwxr-xr-x  8 root root 0 Sep  6 04:29 .
drwxr-xr-x  5 root root 0 Sep  6 04:29 ..
drwxr-xr-x  2 root root 0 Sep  6 04:29 0000:00:02.0
drwxr-xr-x  2 root root 0 Sep  6 04:29 0000:00:02.4
drwxr-xr-x  2 root root 0 Sep  6 04:29 0000:00:02.6
drwxr-xr-x  2 root root 0 Sep  6 04:29 0001:00:02.0
drwxr-xr-x  2 root root 0 Sep  6 04:29 0001:00:02.6
drwxr-xr-x  2 root root 0 Sep  6 04:29 control
```

If the `/sys/bus/pci/slots` directory does not exist, then the PCI core is not loaded.

### rpaphp driver:

The rpaphp driver must be loaded on the system. Type the following command to verify:

```
ls -l /sys/bus/pci/slots/*
```

If the rpaphp driver is loaded, the output will look similar to the following:

```
e1m17c224:/usr/sbin # ls -l /sys/bus/pci/slots/*
/sys/bus/pci/slots/0000:00:02.0:
total 0
drwxr-xr-x  2 root root  0 Sep  6 04:29 .
drwxr-xr-x  8 root root  0 Sep  6 04:29 ..
-r--r--r--  1 root root 4096 Sep  6 04:29 adapter
-rw-r--r--  1 root root 4096 Sep  6 04:29 attention
-r--r--r--  1 root root 4096 Sep  6 04:29 max_bus_speed
-r--r--r--  1 root root 4096 Sep  6 04:29 phy_location
-rw-r--r--  1 root root 4096 Sep  6 04:29 power
```

### Listing information about the I/O slots

Before you replace an HBA using PCI Hotplug, you can use the `lsslot` tool to list information about the I/O slots. This section describes how to use `lsslot`, and provides examples.

**Syntax for the `lsslot` command:** Use the `lsslot` tool as follows:

- Syntax: `lsslot [ -c slot | -c pci [ -a | -o] ] [ -s drc-name ] [ -F delimiter ]`

- Options:

- No options**      Displays all DR slots
- c slot**            Displays all DR slots
- c pci**              Displays all PCI Hotplug slots
- c pci -a**          Displays all available (empty) PCI Hotplug slots
- c pci -o**          Displays all occupied PCI Hotplug slots
- F**                  Uses delimiter to delimit columns

**Listing PCI Hotplug slots using the lsslot command:** This section shows the command lines you can use to list PCI Hotplug slots.

**Note:** In the Device(s) columns of the command-line outputs, the PCI devices in the slots are listed as follows: *xxxx:yy:zz.t*. (For example: 0001:58:01.1)

*List all PCI Hotplug slots:* Type the following command to list all PCI Hotplug slots:

```
# lsslot -c pci -a
```

The resulting output looks similar to the following:

# Slot	Description	Device(s)
U7879.001.DQD014E-P1-C1	PCI-X capable, 64 bit, 133MHz slot	Empty
U7879.001.DQD014E-P1-C2	PCI-X capable, 64 bit, 133MHz slot	0002:58:01.0
U7879.001.DQD014E-P1-C3	PCI-X capable, 64 bit, 133MHz slot	0001:40:01.0
U7879.001.DQD014E-P1-C4	PCI-X capable, 64 bit, 133MHz slot	Empty
U7879.001.DQD014E-P1-C5	PCI-X capable, 64 bit, 133MHz slot	Empty
U7879.001.DQD014E-P1-C6	PCI-X capable, 64 bit, 133MHz slot	0001:58:01.0
0001:58:01.1		

*List all empty PCI Hotplug slots:* Type the following command to list all empty PCI Hotplug slots:

```
# lsslot -c pci -a
```

The resulting output looks similar to the following:

# Slot	Description	Device(s)
U7879.001.DQD014E-P1-C1	PCI-X capable, 64 bit, 133MHz slot	Empty
U7879.001.DQD014E-P1-C4	PCI-X capable, 64 bit, 133MHz slot	Empty
U7879.001.DQD014E-P1-C5	PCI-X capable, 64 bit, 133MHz slot	Empty

*List all occupied PCI Hotplug slots:* Type the following command to list all occupied PCI Hotplug slots:

```
# lsslot -c pci -o
```

The resulting output looks similar to the following:

# Slot	Description	Device(s)
U7879.001.DQD014E-P1-C2	PCI-X capable, 64 bit, 133MHz slot	0002:58:01.0
U7879.001.DQD014E-P1-C3	PCI-X capable, 64 bit, 133MHz slot	0001:40:01.0
U7879.001.DQD014E-P1-C6	PCI-X capable, 64 bit, 133MHz slot	0001:58:01.0
0001:58:01.1		

*Show detailed information about a particular device:* Select a device number from the output of `# lsslot -c pci -o`, as seen in the previous output example, and type the following command to show detailed information about that particular device:

```
# lspci | grep xxxx:yy:zz.t
```

where `xxxx:yy:zz.t` is the number of the PCI Hotplug device. The resulting output looks similar to the following:

```
0001:40:01.0 Ethernet controller: Intel Corp. 82545EM Gigabit  
Ethernet Controller (Copper) (rev 01)
```

## Replacing a PCI Hotplug HBA

**Syntax for the `drsslot_chrp_pci` command:** Use the `drsslot_chrp_pci` tool as follows:

- Syntax: `drsslot_chrp_pci -c slot {-r | -a | -R | -i } -s slot-name`
- Options:
  - r Remove
  - a Add
  - R Replace
  - i Identify

**Replacing an HBA:** Complete the following procedures to replace a PCI Hotplug HBA by using the `drsslot_chrp_pci` command.

**Note:** In these procedures, the variable `slot-name` refers to the slot that contains the HBA that you are replacing.

**Attention:** Before you remove the HBA, you will need to remove the fibre channel cable that is attached to the HBA. The fibre channel cable must remain unattached for at least five minutes to ensure that all I/O activity is transferred to the alternate path. Failure to remove the fibre channel cable can lead to undesirable results.

**1. Identify the PCI Hotplug slot:** Type the following command to identify the PCI Hotplug slot:

```
# drsslot_chrp_pci -i -s slot-name
```

where `slot-name` is the name of the slot for the HBA you are replacing. (Example: U7879.001.DQD014E-P1-C3)

The light at slot `slot-name` begins flashing, and this message displays:

```
The visual indicator for the specified  
PCI slot has been set to the identify  
state. Press Enter to continue or  
enter x to exit.
```

2. *Hot unplug the HBA from the slot:* Complete the following steps to hot unplug (remove) the HBA:

1. Remove the fibre channel cable that is connected to this HBA, and wait for failover to complete.
2. After failover is complete, type the following command:

```
# drslot_chrp_pci -r -s slot-name
```

This message displays:

```
The visual indicator for the specified
PCI slot has been set to the identify
state. Press Enter to continue or
enter x to exit.
```

3. Press **Enter**. This message displays:

```
The visual indicator for the specified
PCI slot has been set to the action state.
Remove the PCI card from the identified slot
and press Enter to continue.
```

4. Press **Enter**.
5. Physically remove the HBA from the slot.
6. Type the following command to verify that the slot is empty:

```
# lsslot -c pci -s slot-name
```

If the slot is empty, the resulting output looks similar to the following:

# Slot	Description	Device(s)
U7879.001.DQD014E-P1-C3	PCI-X capable, 64 bit, 133MHz slot	Empty

3. *Hot plug the HBA into the slot:* Complete the following steps to hot plug the HBA into the slot.

1. Type the following command:

```
# drslot_chrp_pci -a -s slot-name
```

This message displays:

```
The visual indicator for the specified
PCI slot has been set to the identify
state. Press Enter to continue or
enter x to exit.
```



2. Press **Enter**. This message displays:

```
The visual indicator for the specified
PCI slot has been set to the action state.
Insert the PCI card into the identified slot,

connect any devices to be configured
and press Enter to continue. Enter x to exit.
```

3. Insert the new HBA into the slot.
4. Type the following command to verify that the slot is no longer empty:

```
# lsslot -c pci -s slot-name
```

If the slot is not empty, the resulting output looks similar to the following:

```
# Slot          Description          Device(s)
U7879.001.DQD014E-P1-C3  PCI-X capable, 64 bit, 133MHz slot  0001:40:01.0
```

### Reassigning the WWPN on the DS4000 storage subsystem

After you replace the HBA, you must reassign its new WWPN on the DS4000 storage subsystem. Complete the following steps:

1. If RDAC is installed, type the following command to recognize the new HBA:

```
# mppBusRescan
```

2. Start Storage Manager.
3. In the Mappings View of the Storage Manager Subsystem Management window, select the HBA Host Port that was previously assigned to the HBA that you replaced.
4. Right-click the HBA Host Port, then select **Replace....** A new Storage Manager window opens.
5. In the new window, select the new host WWPN from the pull-down menu, or type the WWPN in the New Identifier field.
6. Click **OK** to close the window.
7. Type **mppBusRescan** again. Verify that the newly-replaced HBA recognizes the LUNs by checking the **lsscsi** output.

---

## Remotely installing Linux (SAN boot)

This section describes how to remotely install (SAN boot) a SLES or RHEL Linux operating system onto a Series p host server that is connected by fibre channel to a DS4000 storage subsystem.

### Software requirements

See the following sections for operating system requirements:

- “SUSE Enterprise Linux Server system requirements” on page 151
- “Red Hat Enterprise Linux 4 (RHEL 4) system requirements” on page 153

## Hardware requirements

The following hardware is required:

- IBM @server Series p server(s)
- Supported IBM Series p host bus adapters (HBAs)
- DS4000 storage subsystem

## Assumptions

This procedure assumes the following:

- No installation is present.
- After the installation is complete, the boot and swap devices will run on a DS4000 storage subsystem.

## Preparing for the SAN boot procedure

Complete the following steps before you begin the installation:

1. Be familiar with the following topics:
  - How to connect to and operate an IBM Series p server
  - How to create LUNs on the DS4000 storage subsystem
  - How to set up a SAN network or direct-attached SAN storage devices, so that the configured server can access the DS4000 LUNs
  - How the Linux kernel boot process functions, and what processes and procedures are used to boot a Linux distribution for a local storage device
2. Ensure that you have a copy of your RHEL 4, SLES 9, or SLES 10 operating system installation file available, either on CD or on an accessible network.
3. Verify that the BOOT BIOS is enabled on the HBA devices that are configured for the server. (The BOOT BIOS setting enables discovery and use of SAN disk devices during the installation process.)
4. It is required to remove all but one path to the primary controller for the LUN that will be used for installation. This can be done by pulling a fibre channel cable or by disabling or blocking a fibre channel switch port.
5. Ensure that the size of the boot device that you plan to use is at least 20 GB. (This is the minimum size for installing all packages from the installation media to the boot devices.)

In addition, ensure that the size of the swap device is equivalent to or larger than the size of the server's physical memory.

### Notes:

- a. Disks that are used during the installation process must have their preferred paths set to the DS4000 controller that is attached to the active fibre channel path in the system (and not to the one that you deconfigured in step 4).
- b. For simplicity, the procedure described in this document assumes that the boot, root, and swap devices are all located on the same device. However, this is not a requirement for the installation.

## Steps for performing the SAN boot procedure

The installation media (source for installation) that is used in the following steps is an NFS-exported set of CDs. However, you can use any of the following installation sources:

- CD
- NFS

- HTTP
- FTP
- Other source

**Important:**

1. The initial release of SLES 9 does not adequately support the SAN boot process. When you initially boot the system, boot from one of the currently available service packs before installing the SLES 9 base code.
2. Not all of the details about installation and partitioning are documented in this procedure. To determine which packages are needed for the type of system you are installing, you must refer to your system's installation procedures.

**Note:**

Complete the following steps.

1. From the System Management Services menu (SMS), select your installation source, and boot from the media. (See your server's installation manual for further instructions.)
2. Verify that the HBA module is loaded. (For RHEL, the module is **lpfc**; for SLES, the module is **lpfcdd**.)
3. Verify that the SAN devices you are using for the installation have been detected successfully.

**Note:** If the SAN devices are already configured for multiple path access, Linux discovers the same physical device multiple times—once for each logical path to the device.

4. Note which SAN device will be used for the installation (for example, /dev/sdh.) Also, note which HBA device is used to discover the SAN device. (You will need this information later in the procedure.)
5. **For RHEL:** Select the installation options that are appropriate for your configuration. For partitioning options, select *Autopartition* then select the drive you are using as the installation target. Then, continue to the steps listed in "Completing the RHEL procedure" on page 194.

**For SLES:** Select the installation options that are appropriate for your configuration until the Installation Settings dialog displays. Then complete the following steps:

- a. In the Installation Settings dialog, select *Change*.
- b. In the next dialog that displays, select *Partitioning*.

**Note:** For SLES, partitioning is necessary to ensure that the device that you noted in step 4 is used as the root/boot installation target.

- c. In the Custom Partitioning dialog, select the device, then select *Custom partitioning for experts*.
- d. Ensure that there is a PReP boot partition on the root/boot device, and that it is the first partition.
- e. Continue to partition devices as required to complete this configuration.
- f. Finish the installation.

**Note:** When attempting to create the yaboot boot loader, an error occurs that states that the 'fcp' device type is unknown. Click **OK**, and then select *No* when asked to retry.

- g. Open the SMS menu to reboot from the installation source media. (If you are booting from a CD, continue to a point where you can abort the installation and return to the command-line menu. If you are booting from the network, the command-line menu is already present.)
- h. Select the option to boot from an installed system, select the root device that you just installed, and continue.
- i. When the YaST installation wizard displays, use the wizard to finish the installation.
- j. Continue to “Completing the SLES procedure.”

## Completing the SLES procedure

After you finish the previous steps, you must complete the following steps to finish the SAN boot procedure for the SLES system:

1. Use YaST to upgrade the installed system to the latest SLES 9 service pack. (As of this writing, the latest service pack is SP 3. SLES 10 service packs have not been released yet.)
2. Run the **cat /etc/yaboot.conf** command, and verify that the data in this file looks correct for the boot and root partitions.
3. Run the **yaboot** command. This permits the installation of the yaboot loader to the PReP boot partition of the drive (resolving the installation error that occurred in the previous steps).
4. Reboot again and open the SMS menu. This time, the boot device that you set up in the previous steps is ready to be used. Select the option to boot from a hard drive/SAN, and select the HBA that is associated with the SAN disk device on which the installation was completed.
5. The installation boot device should now be listed in the “bootable” devices that are discovered on the selected HBA. Select the appropriate device, and boot.
6. Set the installed boot device as the default boot device for the system.

**Note:** This step is not required. However, it is recommended to enable unattended reboots after this procedure is complete.

If all of the preceding steps were completed accurately, the SLES system is now booted in single-path mode from the SAN. Complete the following steps to verify the installation:

1. Use the **df** command to check the mounted devices and verify that the root is mounted in the appropriate location.
2. Use the **swapon -s** command to verify that the swap device is correctly mounted.
3. Verify that the other configured partitions are also correctly mounted.

This completes the single-path SAN boot procedure for SLES systems.

**Note:** With dual-path systems, you can now reconfigure the second fibre channel connection that you deconfigured in step 4 of “Preparing for the SAN boot procedure” on page 192, and proceed to “Installing the RDAC Multipath driver” on page 175.

## Completing the RHEL procedure

After you finish the previous steps, you must complete the following steps to finish the SAN boot procedure for the RHEL 4 system:

1. Reboot again and open the SMS menu. This time, the boot device that you set up in the previous steps is ready to be used. Select the option to boot from a hard drive/SAN, and select the HBA that is associated with the SAN disk device on which the installation was completed.
2. The installation boot device should now be listed in the “bootable” devices that are discovered on the selected HBA. Select the appropriate device, and boot.
3. Set the installed boot device as the default boot device for the system.

**Note:** This step is not required. However, it is recommended to enable unattended reboots after this procedure is complete.

If all of the preceding steps were completed accurately, the RHEL system is now booted in single-path mode from the SAN. Complete the following steps to verify the installation:

1. Check the mounted devices, and verify that the root is mounted in the appropriate location.
2. Verify that the swap device and other configured partitions are correctly mounted.

This completes the single-path SAN boot procedure for RHEL systems.

**Note:** With dual-path systems, you can now reconfigure the second fibre channel connection that you deconfigured in step 4 of “Preparing for the SAN boot procedure” on page 192, and proceed to “Installing the RDAC Multipath driver” on page 175.



---

## Chapter 6. Completing the software configuration

After you finish installing DS4000 Storage Manager, you must complete your configuration. This chapter describes how to complete the DS4000 Storage Manager configuration by performing the following tasks:

- “Configuring storage subsystems” on page 201
- “Configuring alert notifications” on page 205
- “Renaming storage subsystems” on page 206
- “Creating a storage subsystem profile” on page 206
- “Performing other storage subsystem management tasks” on page 207

If your subsystem is running at controller firmware version 6.1x.xx.xx or later, you can use the Storage Manager Task Assistant to complete many of the procedures described in this section. See “Using the Task Assistant” for more information.

**Attention:** For cluster configurations, complete all applicable configuration procedures for each storage subsystem *before* installing the storage management software on a second host or cluster server.

---

### Overview of heterogeneous host configurations

The heterogeneous hosts feature enables hosts that are running different operating systems to access a single storage subsystem. DS4000 Storage Manager 9.1x or higher supports up to 64 storage partitions, which enables a multiple host-type subsystem to share storage capacity, consolidate storage, and reduce storage management costs.

Host computers can run on completely different operating systems (for example, AIX and Solaris) or variants of the same operating system (for example, Solaris running in a cluster environment). When you define a host type in the Define New Host Port window, the heterogeneous hosts feature enables the controllers in the storage subsystem to tailor their behavior (such as LUN reporting and error conditions) to the needs of the operating system or variant of the host that is sending the information.

**Important:** When you define host types in a heterogeneous environment, you must set each host type to its appropriate operating system so that the firmware on each controller can respond correctly for the appropriate operating system.

Before you begin setting up the configuration for you heterogeneous host, see the *IBM DS4000 Storage Manager Concepts Guide*.

---

### Using the Task Assistant

The Task Assistant provides a convenient, central location from which you can choose to perform the most common tasks in the Enterprise Management window and in the Subsystem Management window.

If your subsystem is running at controller firmware version 6.1x.xx.xx or later, you can use the Storage Manager Task Assistant to complete many of the procedures described in this section.

In the Enterprise Management window, the Task Assistant provides shortcuts to these tasks:

- Adding storage subsystems
- Naming or renaming storage subsystems
- Setting up alert destinations
- Managing storage subsystems

In the Subsystem Management window, the Task Assistant provides shortcuts to these tasks:

- Configuring storage subsystems
- Saving configurations
- Defining hosts
- Creating a new storage partition
- Mapping additional logical drives

If there is a problem with the storage subsystem, a shortcut to the Recovery Guru appears, where you can learn more about the problem and find solutions to correct the problem.

To open the Task Assistant, choose **View → Task Assistant** from either the Enterprise Management window or the Subsystem Management window, or click the Task Assistant button in the toolbar:



The Task Assistant window opens. See Figure 22 on page 199 for the Enterprise Management window Task Assistant or Figure 23 on page 200 for the Subsystem Management window Task Assistant.



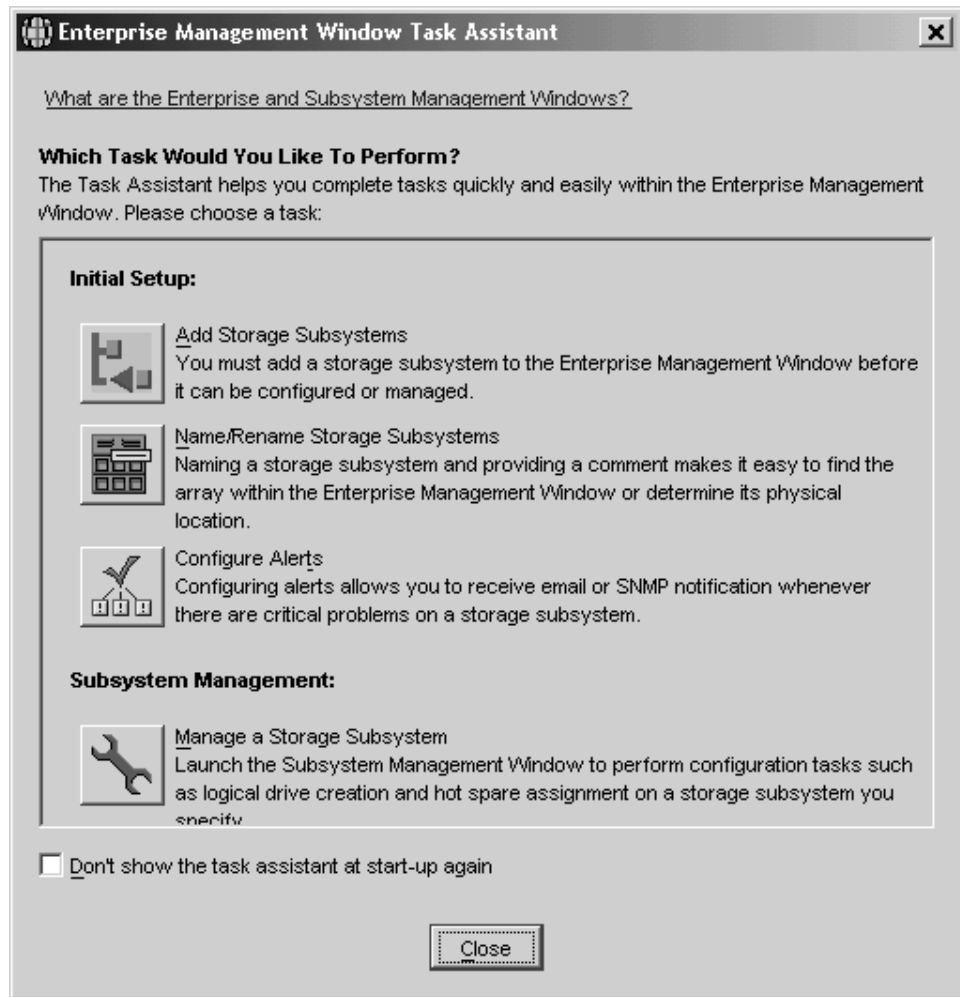

Figure 22. The task assistant in the Enterprise Management window

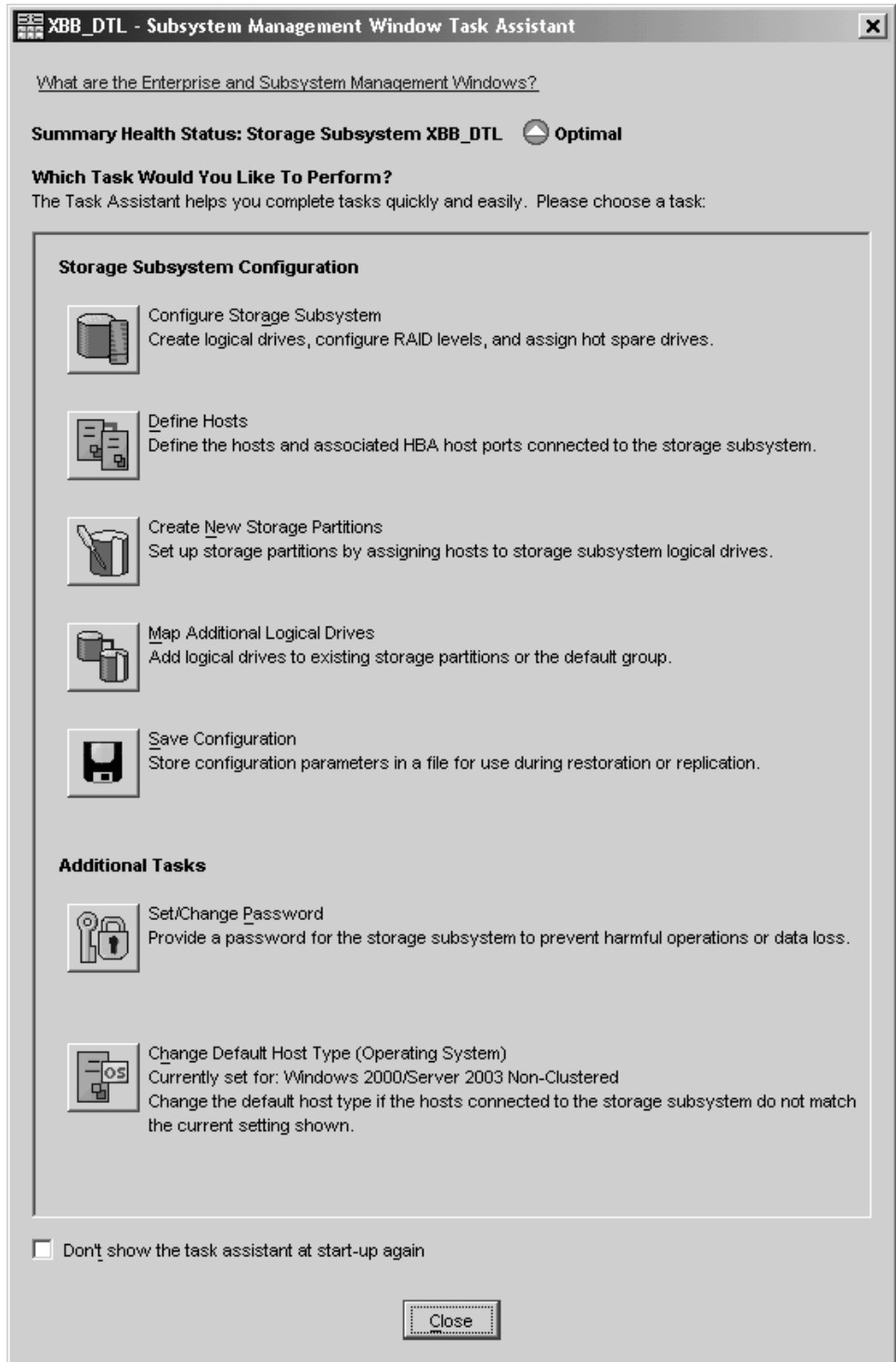

Figure 23. The task assistant in the Subsystem Management window

**Note:** The Task Assistant is automatically invoked every time you open the Subsystem Management window unless you check the **Don't show the task assistant at startup again** check box at the bottom of the window.

## Configuring storage subsystems

Use the following procedures to start the DS4000 SMclient from either the storage management station or from a host that is acting as a storage management station (a host with the client software installed). Use the SMclient to discover and configure each attached storage subsystem.

### Performing an initial automatic discovery of storage subsystems

Complete the following steps to begin an initial automatic discovery of all the attached hosts and storage subsystems:

1. If you are running the DS4000 SMclient from AIX, first change to the /SMclient directory and then type `SMclient`. (For more information about initial automatic discovery on AIX systems, see “Identifying devices on AIX hosts” on page 47.) If you are running the client software from Solaris 8 or 9, type `SMclient`.
2. Click **Yes** to begin the initial automatic discovery.

**Note:** It can take up to one minute for the Enterprise Management window to refresh after an initial automatic discovery. If you need to stop the automatic discovery operation for any reason, close the Enterprise Management window.

When the initial automatic discovery is finished, all attached hosts and attached storage subsystems are displayed in the Subsystem Management window, as shown in Figure 24.

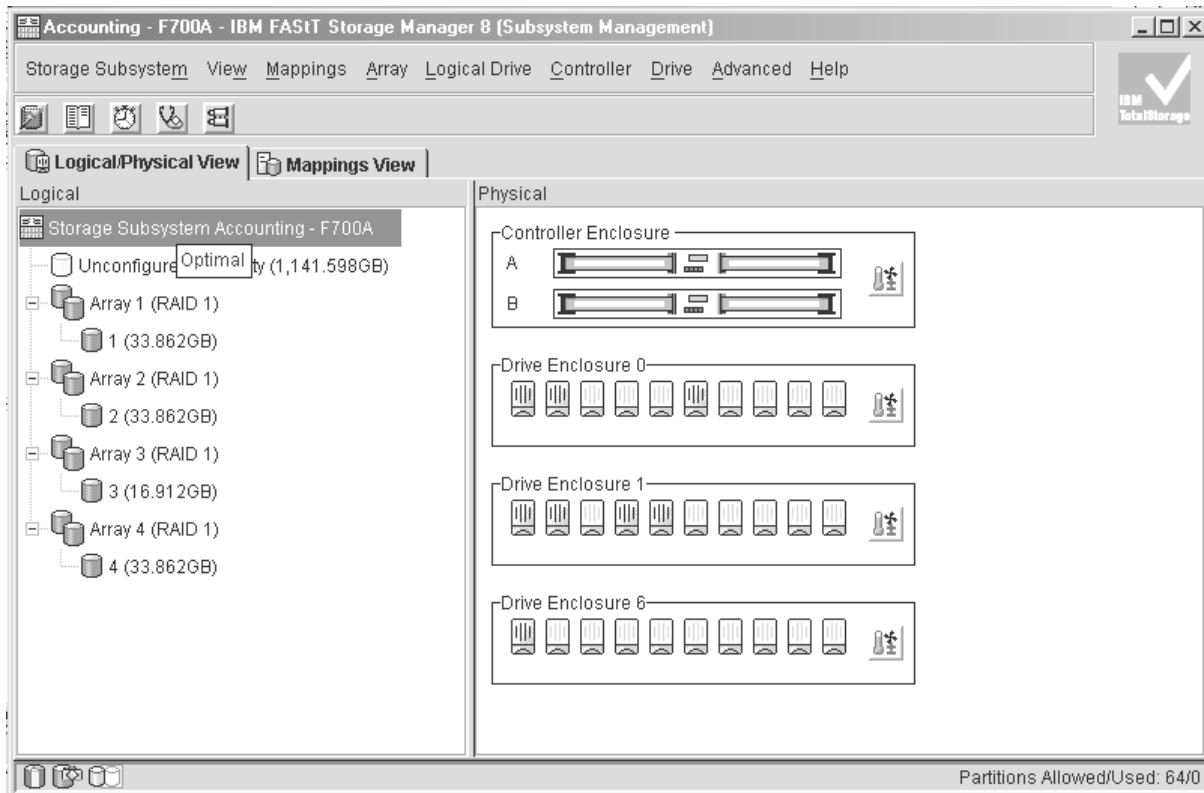

SJ001148

Figure 24. Subsystem Management window

3. Ensure that all of the attached hosts and storage subsystems are displayed as expected. If they are not, complete the following steps:
  - a. Check the hardware and connections for possible problems (see the hardware documentation for specific procedures).
  - b. See the Enterprise Management window help topic on discovering storage subsystems and take the appropriate action that is indicated.
  - c. Ensure that the storage subsystem is on the local subnetwork. If it is not, click **Edit → Add Storage Subsystem** to add it. See the Enterprise Management window help topic on adding devices.

**Note:** Failure to add both controllers results in a partially-managed subsystem.
  - d. If a storage subsystem is duplicated in the device tree after an automatic discovery, remove the duplicate storage subsystem icon from the device tree by clicking **Edit → Remove...** in the Enterprise Management window. Click **Yes** when the dialog window appears.
4. Ensure that the status of each storage subsystem is **Optimal**:
  - If any device shows a status of **Unresponsive**, remove the device from the management domain, and then add it again. See the Enterprise Management window help topic on removing and adding devices.
  - If the device still shows an unresponsive status, contact your IBM technical-support representative.
5. Go to “Configuring alert notifications” on page 205.

## Creating arrays and logical drives

**Important:** You should create a storage subsystem profile and save it in a safe place whenever you modify the arrays and logical drives in your storage subsystem. This saved profile contains detailed controller information, including logical and physical disk configuration information that can help you recover the configuration in the event of a catastrophic failure. Do *not* save the profile *in* the logical drives for which you create this configuration information backup.

To create a storage subsystem profile, select **Storage Subsystem → View Profile** in the Storage Subsystem Management window and click the **Save As** button when the Storage Subsystem Profile window opens. In addition, using firmware version 07.10.xx.xx, you can also select **Advanced → Troubleshooting → Collect All Support Data** as shown in Figure 25 on page 203 to collect all the various types of inventory, status, diagnostic and performance data from this storage subsystem and save them to a single compressed file.

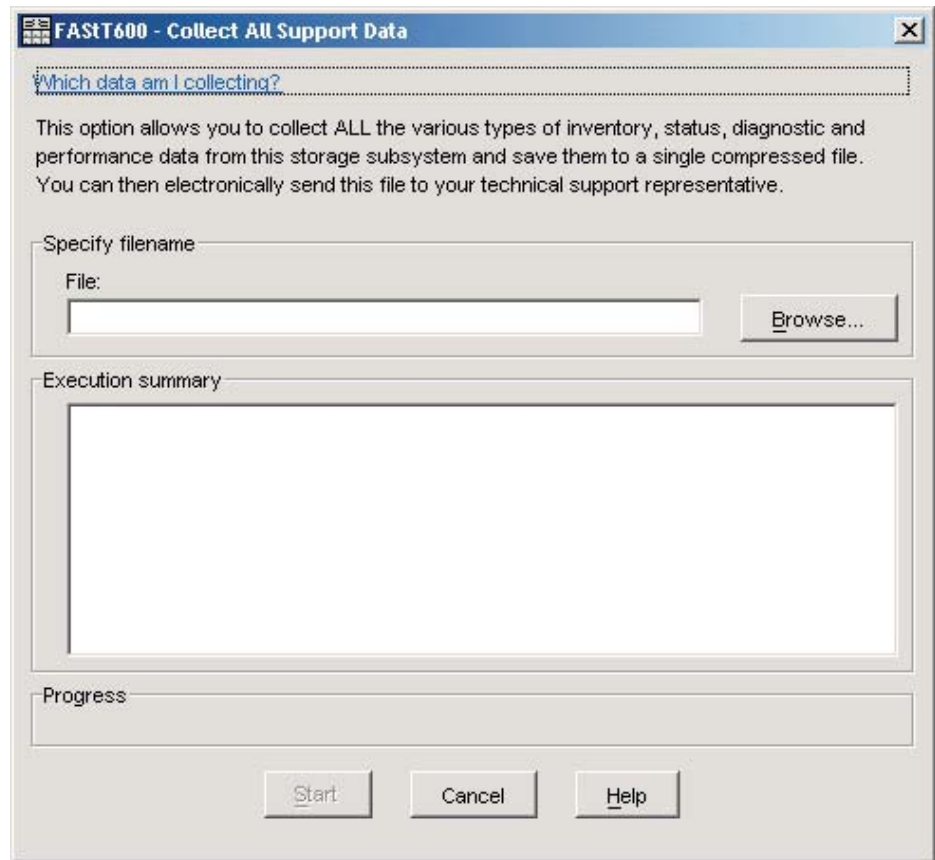

Figure 25. Collect All Support Data window

An *array* is a set of fibre channel or SATA hard drives that are logically grouped together to form a Redundant Array of Independent Disks (RAID).

A *logical drive* is a logical structure, which is the basic structure that you create to store data on the storage subsystem. The operating system recognizes a logical drive as a single drive. Choose a RAID level to meet application needs for data availability and maximize fibre channel I/O performance.

**Maximum number of drives:**

1. For firmware level 06.xx.xx.xx, the maximum number of drives supported in an array is 30, regardless of the hard drive capacity. Each array can be divided into from 1 to 256 logical drives.
2. For firmware levels 05.4x.xx.xx and later, the maximum number of drives supported in an array is 30, regardless of the hard drive capacity. Each array can be divided into from 1 to 256 logical drives.
3. For firmware levels 05.3x.xx.xx and lower, the maximum number of hard drives supported for each array is 30 if the hard drive capacities are 73.4GB or less and 14 if the hard drive capacities are 146GB.

**Note:** For cluster configurations, if you add or delete logical drives, you must make them known to both nodes A and B.

**Creating an array**

In the DS4000 Storage Manager Subsystem Management window, perform the following steps to create an array from unconfigured capacity nodes.

1. Use either of the following two methods to create a new array:
  - Select **Total Unconfigured Capacity** node, and click **Array → Create**, or;
  - Select and right-click **Total Unconfigured Capacity** node, and click **Create Array**.

The Introduction (Create Array) window opens.
2. Click **Next** to continue.
3. The Array Name & Drive Selection (Create Array) window opens.
  - Array name—Enter a name for the new array. This name can be a maximum of 30 characters.
  - Drive selection choices—Select one of the two options.
    - Automatic (Recommended)—Choose from a list of automatically generated drive and capacity options. (This option is preselected by default.)
    - Manual (Advanced)—Choose specific drives to obtain capacity for the new array.
  - Click **Next** to continue.
4. The RAID Level and Capacity (Create Array) window opens. Specify the RAID level (redundancy protection).
5. Select the number of drives (overall capacity) for the new array.
6. Click **Finish**.
7. The Array Created window opens. If, at this point, you want continue the process to create a logical drive, click **Yes**; if you want to wait to create a logical drive at another time, click **No**.

## Creating a logical drive

In the DS4000 Storage Manager Subsystem Management window, perform the following steps to create a logical drive.

1. In the Logical/Physical View tab of the Introduction (Create Logical Drive) window, you will see how much Free Capacity is available for all existing arrays. Select the **Free Capacity** of an array for which you want to create a new logical drive; then, right-click and select **Create Logical Drive**.
2. Click **Next**.
3. In the Specify Capacity/Name (Create Logical Drive) window, specify the following parameters for the logical drive you are creating.

### New logical drive capacity

The capacity can either be the entire unconfigured capacity in an array or a portion of the array's capacity.

**Units** Choose GB, MB, or TB, depending upon the capacity available.

**Name** Choose a name that is unique in the storage subsystem, up to a maximum of 30 characters.

4. Under Advanced logical drive parameters, select from one of the options.
  - Use recommended settings
  - Customize settings (I/O characteristics and controller ownership)

You can create the logical drive using the DS4000 storage subsystem recommended settings, or you can customize your I/O characteristics, controller ownership, and logical-drive-to-LUN mapping settings. To use the recommended (default) settings, select **Use recommended settings**, and click

**Next**, then proceed to step 6. If you want to customize your settings, select **Customize settings**, and click **Next**, then proceed to step 5.

5. In the Advanced logical drive parameters window, specify the appropriate I/O characteristics (characteristics type, segment size, and cache read-ahead multiplier).

The I/O characteristics settings can be set automatically or they can be manually specified, based on one of the following logical drive usages—file system, database, or multimedia. Click **Next**. The Specify Logical Drive-to-LUN Mapping (Create Logical Drive) window opens.

6. In the Specify Logical Drive-to-LUN Mapping (Create Logical Drive) window, specify the logical drive-to-LUN mapping.

The logical drive-to-LUN mapping preference can be one of the following two settings:

#### **Default mapping**

The Automatic setting specifies that a LUN is automatically assigned to the logical drive using the next available LUN within the default host group. This setting grants logical drive access to host groups or host computers that have no specific logical drive-to-LUN mappings (those that were designated by the default host group node in the Topology view). If the Storage Partition feature is not enabled, you must specify the Automatic setting. In addition, you can also change the host type to match the host operating system.

#### **Map later using the Mappings View**

This setting specifies that you are not going to assign a LUN to the logical drive during creation. This setting enables you to define a specific logical drive-to-LUN mapping and create storage partitions using the Mappings Defined option. When you enable storage partitioning, specify this setting.

7. Click **Finish** to create the logical drive. The Creation Successful (Create Logical Drive) window opens and states that the logical drive was successfully created.
8. In the Creation Successful (Create Logical Drive) window, click **Yes** and proceed to step 9, if you want to create another logical drive; otherwise, click **No**. When the Completed (Create Logical Drive) window opens, click **OK**, and continue with step 10.
9. In the Allocate Capacity (Create Logical Drive) window, choose to create the new logical drive from free capacity on the same array, free capacity on a different array, or from unconfigured capacity (create a new array). Then continue with step 1 on page 204.
10. The Completed (Create Logical Drive) window opens. Click **OK**.
11. Register the logical drive with the operating system.

After you create logical drives with automatic logical drive-to-LUN mappings, follow the appropriate instructions in the Installation and Support Guide for your operating system to allow it to discover the new logical drive.

---

## **Configuring alert notifications**

After you have added devices to the management domain, you should set up alert notification options to report critical events on the storage subsystems. The following alert notification options are available:

- Alert notifications are sent to a designated network management station (NMS) using simple network management protocol (SNMP) traps.
- Alert notifications are sent to a designated e-mail address. See the Enterprise Management window help for specific procedures. To send e-mail to IBM, contact your customer service representative.
- Alert notifications are sent to a designated alphanumeric pager when third-party software is used to convert e-mail messages. See the Enterprise Management window help for specific procedures.

For more information about notification options, see the *IBM DS4000 Storage Manager Concepts Guide*.

Complete the following steps to set up alert notifications using SNMP traps. You need to set up the designated management station only once.

1. Ensure that the installation CD is inserted in the CD-ROM drive on your designated NMS.
2. From the installation CD, copy the SM9.MIB file from the SM9mib directory to the NMS.
3. Follow the steps required by your NMS to compile the MIB. For details, contact your network administrator or see the documentation for the storage management product you are using.

---

## Renaming storage subsystems

When you start the storage management software for the first time, the storage subsystems are unnamed. In the Subsystem Management window, click **Storage Subsystem** → **Rename**. Rename each storage subsystem from <unnamed> to a name that is appropriate for your network.

---

## Creating a storage subsystem profile

Create a storage subsystem profile and save it in a safe place whenever you modify the arrays and logical drives in your storage subsystem. This profile contains detailed controller information, including logical and physical disk configuration information. In the event of a catastrophic failure, you can use the storage subsystem profile to help recover the configuration.

Complete the following steps to create a storage subsystem profile:

1. In the Storage Subsystem Management window, click **Storage Subsystem** → **View Profile**. The Storage Subsystem Profile window opens.
2. Click **Save As**.
3. Type a file name for the storage subsystem profile and save it to a directory.

If you have a storage subsystem with firmware 04.01.xx.xx or earlier, you must also perform a controller state capture in addition to saving the storage subsystem profile. To use the Capture State Information feature, upgrade your controller to the latest firmware available for your storage subsystem.

Complete the following steps to create a storage subsystem profile by using the Capture State Information feature.

1. Click **Advanced** → **Troubleshooting** → **Capture State Information**. The State Capture window opens.
2. Click **Browse** to specify the file name for the state capture information.



3. Click **Start** to start the capture process.
4. Click **Cancel** to close the State Capture window when the capture is complete.

---

## Performing other storage subsystem management tasks

You can also perform other storage subsystem management tasks at this time. To perform the following tasks and other storage subsystem management tasks, see the appropriate topics in the Subsystem Management window online help:

- Locate a storage subsystem
- View a storage subsystem profile
- Configure a storage subsystem password
- Create and manage arrays and array groups
- Use the performance monitor
- Create storage partitions (if Storage Partitioning is enabled on your system)
- Download drive firmware

If you are installing the storage management software in a cluster environment, repeat all applicable client software installation procedures for a second storage management station and for all applicable host software on a second host. See the following sections for installation instructions:

- Chapter 4, “Installing and configuring storage management software on Solaris host systems,” on page 107
- Chapter 5, “Installing and configuring storage management software on POWER-based Linux host systems,” on page 151
- Chapter 6, “Completing the software configuration,” on page 197



---

## Chapter 7. Using DS4000 Storage Manager with high-availability cluster services

The high-availability clustering services provided by DS4000 Storage Manager allow application services to continue when a hardware or software failure occurs. This system protects you from software failures as well as from the failure of a CPU, disk, or LAN component. If a component fails, its redundant partner component takes over cluster services and coordinates the transfer between components.

---

### General information

This document does not describe how to install or configure cluster services. Refer to documentation that is provided with your cluster service products for this information.

**Important:**

The information in this document might not include up-to-date cluster software version levels.

For the latest requirements and user information about using DS4000 Storage Manager with cluster services, see the readme file that is located in the DS4000 Installation CD for your host operating system, or check the most recent readme files online.

See “Readme files and concepts” on page 1 for instructions on finding the readme files online.

You can also find more information on the DS4000 Interoperability matrix, which is maintained at the following Web site:

[www-1.ibm.com/servers/storage/disk/ds4000/interop-matrix.html](http://www-1.ibm.com/servers/storage/disk/ds4000/interop-matrix.html)

---

### Using cluster services on HP-UX systems

The information in this document might not show up-to-date cluster software version levels. Check the Storage Manager readme file for HP-UX for up-to-date information about clustering requirements. See “Readme files and concepts” on page 1 for instructions on finding the readme file online.

You can also refer to the DS4000 Interoperability Matrix at the following Web site:

[www-1.ibm.com/servers/storage/disk/ds4000/interop-matrix.html](http://www-1.ibm.com/servers/storage/disk/ds4000/interop-matrix.html)

You can choose among many configurations when you set up clustering on an HP-UX system. A minimum configuration consists of two servers that are configured with both a primary and two standby LANs to establish a heartbeat LAN.

Provide fibre channel connections to the storage subsystem through two switches that provide the necessary redundant data path for the hosts. Ensure that each server has two HP Tachyon host bus adapters.

For more information, see Appendix E, “Limitations,” on page 241.

---

## Using cluster services on Solaris systems

The following sections contain general hardware requirements and additional information about the cluster services.

### Important:

The information in this document might not show up-to-date cluster software version levels. Check the Storage Manager readme file for Solaris for up-to-date information about clustering requirements, including the latest supported versions of VERITAS Cluster Server. See “Readme files and concepts” on page 1 for instructions on finding the readme file online.

You can also refer to the DS4000 Interoperability Matrix at the following Web site:

[www.ibm.com/servers/storage/disk/ds4000/interop-matrix.html](http://www.ibm.com/servers/storage/disk/ds4000/interop-matrix.html)

## General hardware requirements

Each Solaris system in the cluster requires the following hardware:

- At least three Ethernet ports:
  - Two for the private network connections
  - At least one for the public network connection
- Two fibre channel host bus adapters for connection to the storage subsystem
- A SCSI connection for operating system disks
- Each VERITAS Cluster Server system requires at least 128 MB of RAM and 35 MB of free disk space

## System dependencies

This section provides information about VERITAS VolumeManager, RDAC IDs, and single points of failure.

### VERITAS VolumeManager and Data Multipathing

If you are using RDAC as your failover driver, and you are using the VERITAS VolumeManager, you must disable Data Multipathing (DMP). Complete one of the following procedures, according to your version of VERITAS VolumeManager.

**Note:** If you are using the VERITAS Cluster Server, you must change the stack size parameters. Open the `/etc/system` file in the Vi text editor and make the following changes:

- Change the default value for `set lwp_default_stksize` to `0x8000`
- Change the default value for `set rcpcmod:svc_default_stksize` to `0x8000`

**VERITAS VolumeManager 3.1 or earlier:** For VERITAS VolumeManager 3.1 or earlier, you must disable DMP for all devices.

Complete the following steps:

1. Open the `/etc/system` file in the vi Editor by typing the following command:

```
# vi /etc/system
```

2. Comment out the `forceload: drv/vxdmp` line.

3. Save and close the /etc/system file.

### RDAC IDs

Add up to eight additional IDs to the /etc/symsm/rmparams file. Complete the following steps to add them:

1. Open the /etc/symsm/rmparams file in the vi Editor by typing the following command:

```
# vi /etc/symsm/rmparams
```

2. Modify the Rdac\_HotAddIDs line as follows:

```
Rdac_HotAddIDs:0:1:2:3:4:5:6:7:8
```

3. Save and close the /etc/symsm/rmparams file.

### Single points of failure

When setting up cluster services, it is important to eliminate single points of failure because a single point of failure makes a cluster only as strong as its weakest component. Set up the storage subsystem for shared storage; for example, all the nodes in the cluster must recognize the same storage and the host types must be set correctly.

---

## Using cluster services on AIX systems

The following sections contain general hardware requirements and additional information about the cluster services.

### Important:

The information in this document might not show up-to-date cluster software version levels. Check the Storage Manager readme file for AIX for up-to-date information about clustering requirements. See “Readme files and concepts” on page 1 for instructions on finding the readme file online.

You can also refer to the following Web sites for the most current information about AIX and clustering:

[www-1.ibm.com/servers/storage/disk/ds4000/interop-matrix.html](http://www-1.ibm.com/servers/storage/disk/ds4000/interop-matrix.html)

<http://publib.boulder.ibm.com/infocenter/clresctr/index.jsp>

## General hardware requirements

For hardware, software, firmware and RDAC requirements, see Appendix C, “Downloading ESM firmware and drive firmware,” on page 229.

## High Availability Cluster Multi-Processing

This section contains general requirements and usage notes for High Availability Cluster Multi-Processing (HACMP) support with DS4000 Storage Manager.

### Software requirements

For the latest supported HACMP versions, see the DS4000 Interoperability Matrix at the following Web site:

## Configuration limitations

The following limitations apply to HACMP configurations:

- HACMP C-SPOC cannot be used to add a DS4000 disk to AIX using the *Add a Disk to the Cluster* facility.
- HACMP C-SPOC does not support enhanced concurrent mode volume groups.
- Single-HBA configurations are allowed, but each single-HBA configuration requires that both controllers in the DS4000 be connected to a switch, within the same SAN zone as the HBA.

**Attention::** Although single-HBA configurations are supported, they are not recommended for HACMP environments because they introduce a single point-of-failure in the storage I/O path.

- Switched fabric connections between the host nodes and the DS4000 storage subsystem are recommended. However, direct attachment from the host nodes to the DS4000 storage subsystem in an HACMP environment is supported, *only* if all the following restrictions and limitations are met:
  - Only dual-controller DS4000 storage subsystem versions are supported for direct attachment in a high-availability (HA) configuration.
  - The AIX operating system must be version 05.2 or later.
  - The HACMP clustering software must be version 05.1 or later.
  - All host nodes that are directly attached to the DS4000 storage subsystem must be part of the same HACMP cluster.
  - All logical drives (LUNs) that are surfaced by the DS4000 storage subsystem are part of one or more enhanced concurrent-mode volume groups.
  - The volume group **varyon** is in the active state *only* on the host node that owns the HACMP non-concurrent resource group (which contains the enhanced concurrent-mode volume group or groups). For all other host nodes in the HACMP cluster, the enhanced concurrent-mode volume group **varyon** is in the passive state.
  - Direct operations on the logical drives in the enhanced concurrent-mode volume groups cannot be performed, from any host nodes in the HACMP cluster, if the operations bypass the Logical VolumeManager (LVM) layer of the AIX operating system. For example, you cannot use a DD command while logged in as the root user.
  - Each host node in the HACMP cluster must have two fibre channel connections to the DS4000 storage subsystem. One direct fibre channel connection must be to controller A in the DS4000 storage subsystem, and the other direct fibre channel connection must be to controller B in the DS4000 storage system.
  - You can directly attach a maximum of two host nodes in an HACMP cluster to a dual-controller version of a DS4100 or DS4300 storage subsystem.
  - You can directly attach a maximum of two host nodes in an HACMP cluster to a DS4000 storage subsystem. Each host node must have two direct fibre channel connections to the storage subsystem.

**Note:** In a DS4400 or DS4500 storage subsystem, the two direct fibre channel connections from each host node must to independent miniHUBs. Therefore, this configuration requires that four host miniHUBs (feature code 3507) be installed in the DS4400 or DS4500 storage subsystem—two host miniHUBs for each host node in the HACMP cluster.

## Other HACMP usage notes

The following notations are specific to HACMP environments:

- HACMP clusters can support from two to 32 servers on each DS4000 partition. If you run this kind of environment, be sure to read and understand the AIX device drivers queue depth settings that are described in Chapter 4, “Installing and configuring storage management software on Solaris host systems,” on page 107.
- You can attach non-clustered AIX hosts to a DS4000 that is running DS4000 Storage Manager and is attached to an HACMP cluster. However, you must configure the non-clustered AIX hosts on separate host partitions on the DS4000.

## Parallel System Support Programs and General Parallel File System

This section contains general requirements and usage notes for Parallel System Support Programs (PSSP) and General Parallel File System™ (GPFS™) support with DS4000 Storage Manager.

### Software requirements

For the latest supported PSSP and GPFS versions, see the DS4000 Interoperability Matrix at the following Web site:

[www.ibm.com/servers/storage/disk/ds4000/interop-matrix.html](http://www.ibm.com/servers/storage/disk/ds4000/interop-matrix.html)

### Configuration limitations

The following limitations apply to PSSP and GPFS configurations:

- Direct connection is not allowed between the host node and a DS4000 storage subsystem. Only switched fabric connection is allowed.
- RVSD clusters can support up to two IBM Virtual Shared Disk and RVSD servers for each DS4000 partition.
- Single node quorum is not supported in a dual-node GPFS cluster with DS4000 disks in the configuration.
- Heterogeneous configurations are not supported.

### Other PSSP and GPFS usage notes

In GPFS file systems, the following DS4000 cache settings are supported:

- Read cache enabled or disabled
- Write cache enabled or disabled
- Cache mirroring enabled or disabled (depending upon the write cache mirroring setting)

The performance benefits of read or write caching depends on the application.

## GPFS, PSSP, and HACMP cluster configuration diagrams

The diagrams in this section show both the preferred and failover paths from an HBA pair to a given volume or set of volumes.

A preferred path to a volume is determined when the volume is created and distributed across a DS4000 controller. The controller to which it is assigned determines which path is preferred or active for I/O transfer. Volumes can, and in most cases should, be assigned to both controllers, balancing the I/O load across HBAs and DS4000 controllers.

Figure 26 shows a cluster configuration that contains a single DS4000 storage subsystem, with one to four partitions.

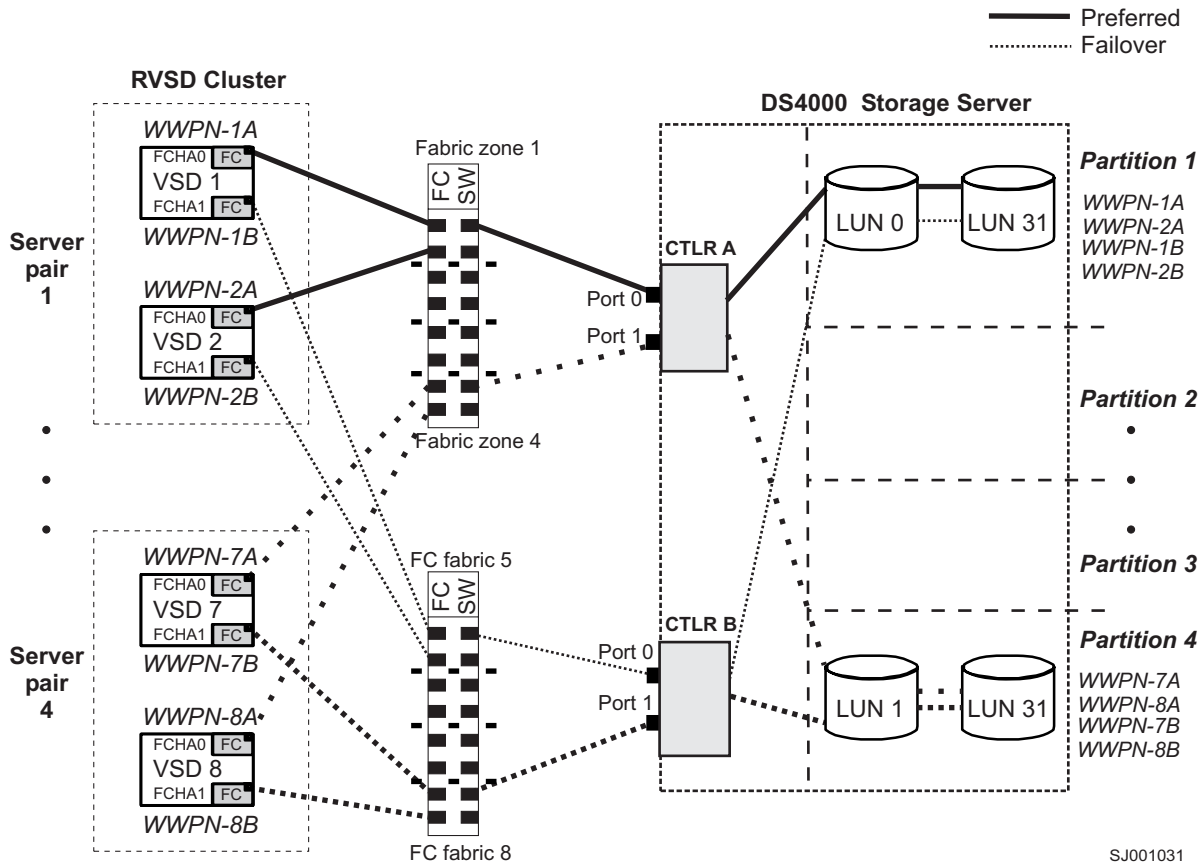

Figure 26. Cluster configuration with single DS4000 storage subsystem—one to four partitions

Figure 27 on page 215 shows a cluster configuration that contains three DS4000 storage subsystems, with one partition on each storage subsystem.



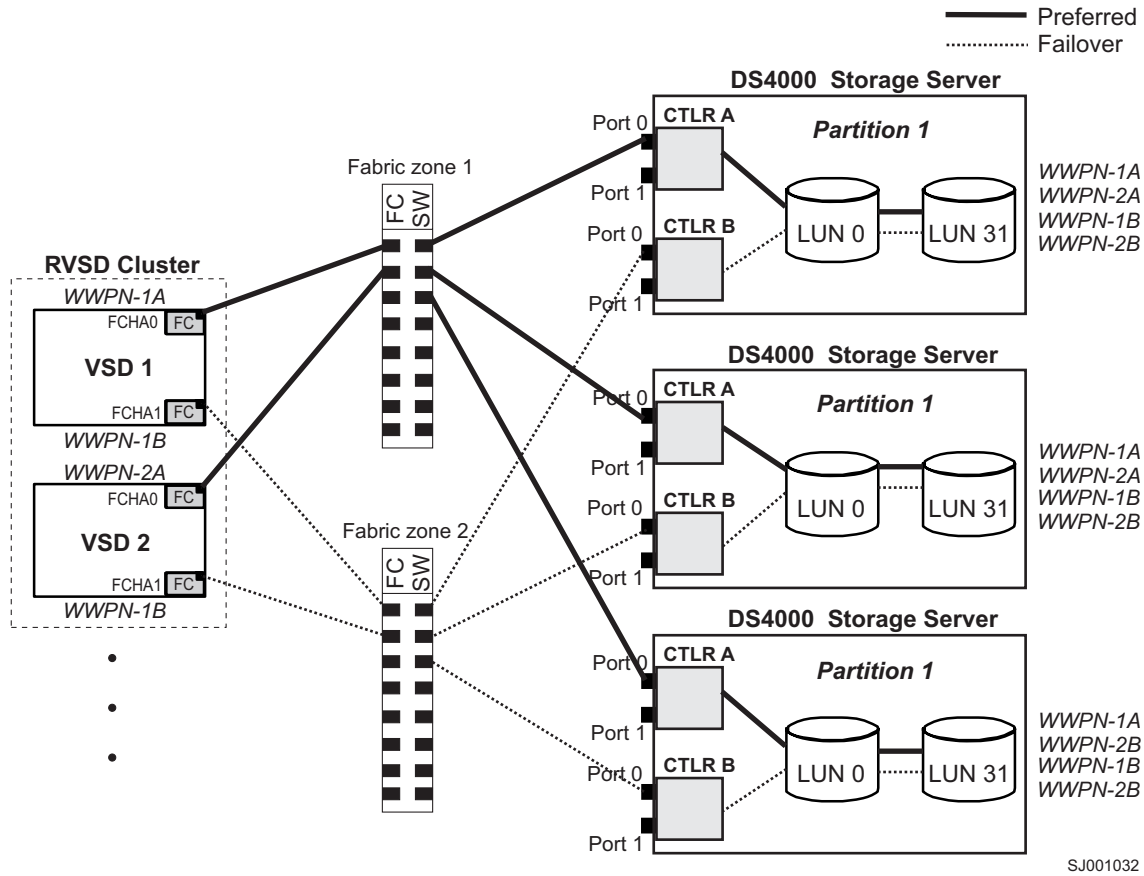

Figure 27. Cluster configuration with three DS4000 storage subsystems—one partition per DS4000

Figure 28 on page 216 shows a cluster configuration that contains four DS4000 storage subsystems, with one partition on each storage subsystem.

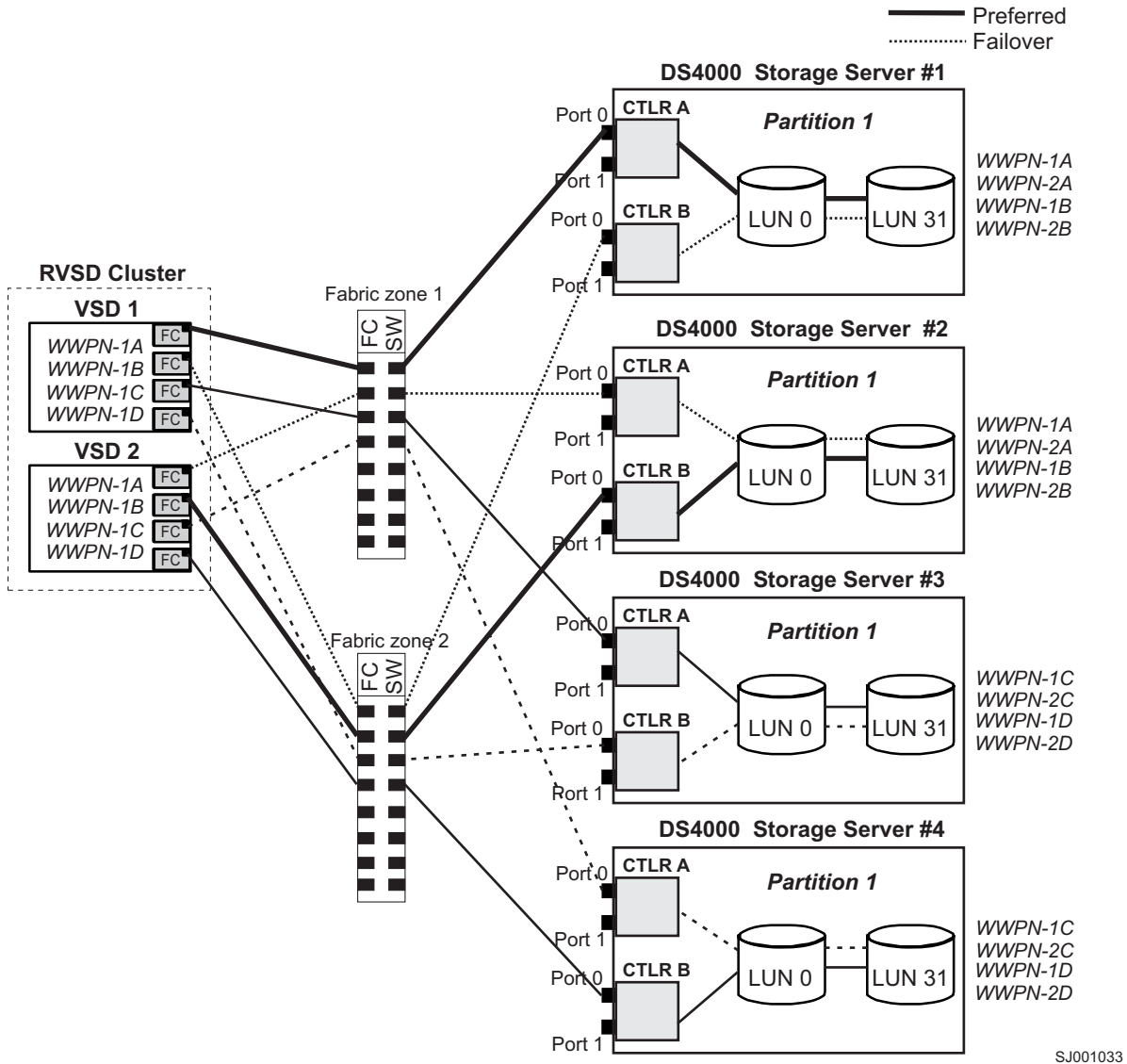

Figure 28. Cluster configuration with four DS4000 storage subsystems—one partition per DS4000

Figure 29 on page 217 shows a cluster configuration that contains two DS4000 storage subsystems, with two partitions on each storage subsystem.

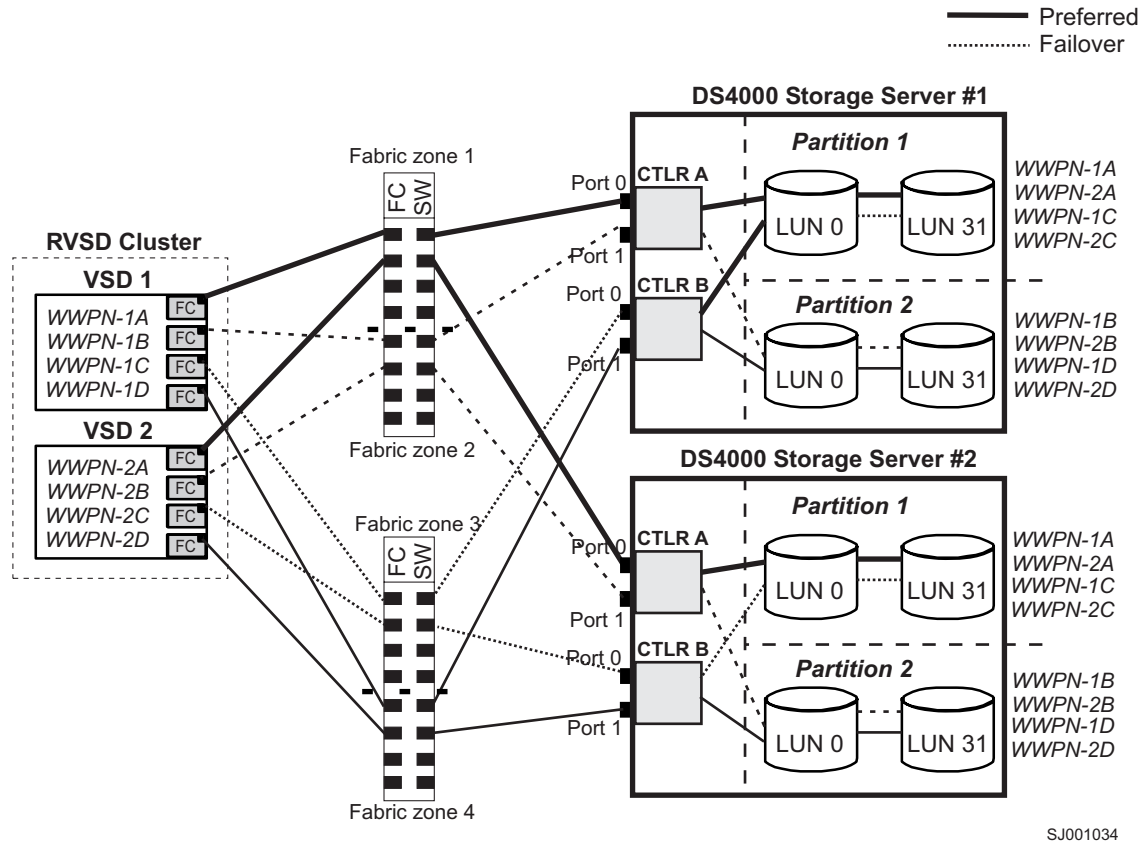

Figure 29. RVSD cluster configuration with two DS4000 storage subsystems—two partitions per DS4000

Figure 30 on page 218 shows an HACMP/GPFS cluster configuration that contains a single DS4000 storage subsystem, with one partition.

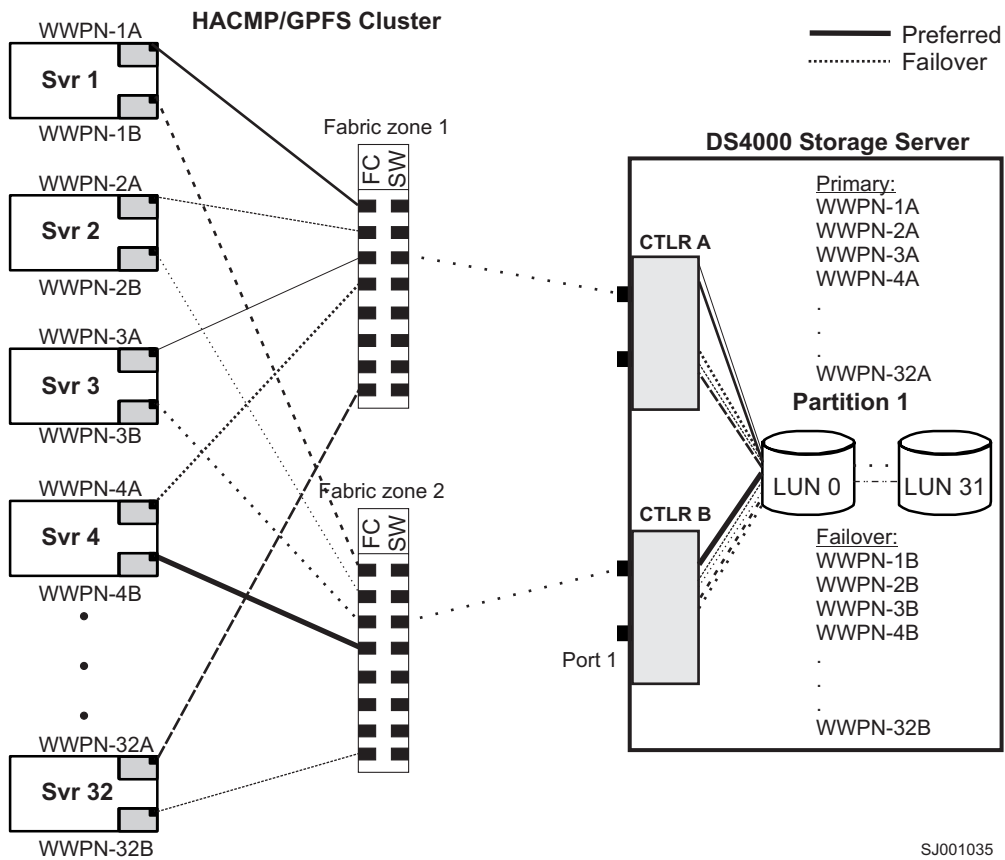

Figure 30. HACMP/GPFS cluster configuration with one DS4000 storage subsystem—one partition

Figure 31 on page 219 shows an HACMP/GPFS cluster configuration that contains two DS4000 storage subsystems, with two partitions on each storage subsystem.

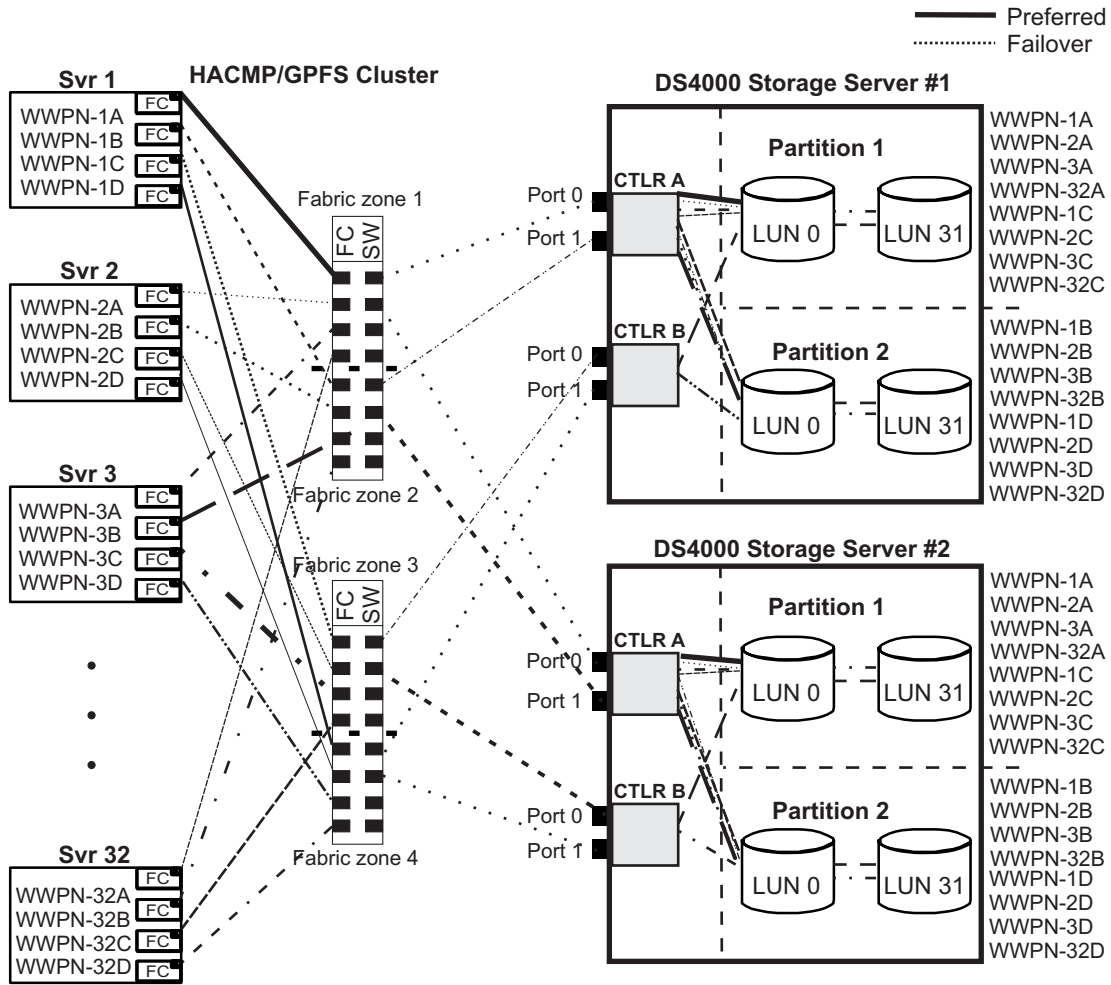

Figure 31. HACMP/GPFS cluster configuration with two DS4000 storage subsystems—two partitions per DS4000



---

## Appendix A. MC/Service Guard configuration details

**Note:** The Hewlett-Packard publication *Managing MC/ServiceGuard* suggests using **vgimport -m -s** with LVM commands during the configuration distribution process. It is important to consider, however, that the **vgimport** command does not preserve the primary and alternate paths of the imported volume groups.

When **vgimport** reconstructs the newly imported volume groups, entries are made in the `/etc/lvmtab` file. In this process of reconstruction, the system reorders disks in the file. The revised order of LUNs on the list causes LUNs to remain on non-preferred paths after failover. You might expect this condition to occur during distribution of the volume groups using the following LVM command:

```
vgimport -s -m /tmp/vg_group_name.map /dev/vg_group_name
```

where `vg_group_name` is the name of the volume group that is being distributed.

This precaution applies only when you use the `-s` option to import devices or disks with redundant paths. The condition occurs because the `-s` option causes a search on the system for each disk when used with **vgimport**.

When the new list is prepared, the links that were previously designated as primary and alternate might not remain as they had been configured on node *A*.

Complete the following steps to correct the paths that were changed in this way when using **vgimport -m -s** with LVM commands.

**Note:** The following instructions are for a two-node cluster. You can easily expand or adapt these instructions to accommodate a cluster which has more than two nodes.

1. Identify and note the primary and alternate paths for each device by typing the following command:

```
# SMdevices
```

2. Compare the primary and alternate paths for each device on node *A* to Node *B* by using the **vgdisplay -v** command. As previously noted, an expected behavior of the **vgimport -m -s** command is that the primary and alternate paths change during export.

On node *A*:

```
#vgdisplay -v volume_group_name
```

where `vg_group_name` is the name of the volume group whose paths you want to display.

On node *B*:

```
#vgdisplay -v volume_group_name
```

where `vg_group_name` is the name of the volume group whose paths you want to display.

3. If the original primary path of a disk becomes an alternate path after the newly imported volume group entry is created in `/etc/lvmtab`, the order can be easily reverted by using **vgreduce** to remove the wrong primary path and then using

**vgextend** to add the path back again:

```
#vgreduce  
vg1 /dev/dsk/device_name#vgextend  
vg1 /dev/dsk/device_name
```



## Appendix B. JNI and QLogic host bus adapter settings

The following tables detail settings for the various host bus adapter (HBA) cards for Sun Solaris.

**Note:** JNI host bus adapters are supported only on Solaris 8 and 9. They are not supported on Solaris 10.

### JNI HBA card settings

The JNI cards are not plug-and-play with autoconfiguration. Instead, you might need to change the settings or bindings.

### Configuration settings for FCE-1473/FCE-6460/FCX2-6562/FCC2-6562

These JNI HBAs (FCE-1473, FCE-6460, FCX2-6562, and FCC2-6562) are supported with all currently-supported levels of DS4000 controller firmware.

**Important:** For all settings that are listed in Table 20, you must uncomment the line. This is true for both default settings and for settings that you must change.

For more information about setting the attributes for JNI HBAs, see “Modifying the HBA settings and binding the HBAs” on page 125.

Table 20. Configuration settings for FCE-1473/FCE-6460/FCX2-6562/FCC2-6562

Original value	New value
FcLoopEnabled = 1	FcLoopEnabled = 0 (for non-loop; auto-topology) FcLoopEnabled = 1 (for loop) <b>Note:</b> See “Modifying the JNI HBA settings for a IBM SAN 2 GB switch” on page 128 for more information about setting these parameters.
FcFabricEnabled = 0	FcFabricEnabled = 0 (for non-fabric; auto-topology) FcFabricEnabled = 1 (for fabric) <b>Note:</b> See “Modifying the JNI HBA settings for a IBM SAN 2 GB switch” on page 128 for more information about setting these parameters.
FcEngHeartbeatInterval = 5	Same as original value (in seconds).
FcLinkUpRecoveryTime = 1000	Same as original value (in milliseconds).
BusRetryDelay = 5000	Same as original value (in milliseconds).
TargetOfflineEnable = 1	TargetOfflineEnable = 0 (Disable) TargetOfflineEnable = 1 (Enable)
FailoverDelay = 30;	FailoverDelay = 60 (in seconds)
FailoverDelayFcTape = 300	Same as original value (seconds).
TimeoutResetEnable = 0	Same as original value.
QfullRetryCount = 5	Same as original value
QfullRetryDelay = 5000	Same as original value (in milliseconds).
LunRecoveryInterval = 50	Same as original value (in milliseconds).
FcLinkSpeed = 3	Same as original value. (This value [auto-negotiate] is the recommended setting.)
JNICreationDelay = 1	JNICreationDelay = 10 (in seconds)

Table 20. Configuration settings for FCE-1473/FCE-6460/FCX2-6562/FCC2-6562 (continued)

Original value	New value
FlugiRetryCount = 3	Same as original value.
FcFlugiTimeout = 10	Same as original value (in seconds).
PlogiRetryCount = 3	Same as original value.
PlogiControlSeconds = 30	Same as original value (in seconds).
LunDiscoveryMethod = 1	Same as original value (LUN reporting).
CmdTaskAttr = 0	CmdTaskAttr = 0 (Simple Queue) CmdTaskAttr = 1 (Untagged)
automap = 0	automap = 1 (Enable)
FclpEnable = 1	FclpEnable = 0 (Disable)
OverrunFailoverCount = 0	Same as original value.
PlogiRetryTime = 50	Same as original value.
SwitchGidPtSyncEnable = 0	Same as original value.
target_throttle = 256	Same as original value.
lun_throttle = 64	Same as original value.
Add these settings. (See “Modifying the HBA settings and binding the HBAs” on page 125 for procedures.)	target0_hba = “jnic146x0”;
	target0_wwpn = “<controller wwpn>”
	target1_hba = “jnic146x1”;
	target1_wwpn = “<controller wwpn>”

**Note:** You might need to run the `/etc/raid/bin/genjnicnf` reconfigure script from the Solaris shell.

```
# /etc/raid/bin/genjnicnf
```

## Configuration settings for FCE-1063/FCE2-1063/FCE-6410/FCE2-6410

These JNI HBAs (FCE-1063, FCE2-1063, FCE-6410, and FCE2-6410) are supported with all currently-supported levels of DS4000 controller firmware.

**Important:** For all settings that are listed in Table 21, you must uncomment the line. This is true for both default settings and for settings that you must change.

For more information about setting the attributes for JNI HBAs, see “Modifying the HBA settings and binding the HBAs” on page 125.

Table 21. Configuration settings for FCE-1063/FCE2-1063/FCE-6410/FCE2-6410

Original value	New value
FcLoopEnabled = 1	FcLoopEnabled = 0 (for non-Loop) FcLoopEnabled = 1 (for Loop) <b>Note:</b> See “Modifying the JNI HBA settings for a IBM SAN 2 GB switch” on page 128 for more information about setting these parameters.
FcFabricEnabled = 0	FcFabricEnabled = 0 (for non-fabric) FcFabricEnabled = 1 (for fabric) <b>Note:</b> See “Modifying the JNI HBA settings for a IBM SAN 2 GB switch” on page 128 for more information about setting these parameters.

Table 21. Configuration settings for FCE-1063/FCE2-1063/FCE-6410/FCE2-6410 (continued)

Original value	New value
FcPortCfgEnable = 1	FcPortCfgEnable = 0 (port reconfiguration not required) FcPortCfgEnable = 1 (port reconfiguration required)
FcEngHeartbeatInterval = 5	Same as original value (in seconds).
FcLrrTimeout = 100	Same as original value (in milliseconds).
FcLinkUpRecoverTime = 1000	Same as original value (in milliseconds).
BusyRetryDelay = 5000	Same as original value (in milliseconds).
FailoverDelay = 30;	FailoverDelay = 60;
TimeoutResetEnable = 0	Same as original value.
QfullRetryCount = 5	Same as original value.
QfullRetryDelay = 5000	Same as original value (in milliseconds).
IoRecoveryDelay = 50	Same as original value (in milliseconds).
JniCreationDelay = 5;	JniCreationDelay = 10;
FlogiRetryCount = 3	Same as original value.
PlogiRetryCount = 5	Same as original value.
FcEmldEndTcbTimeCount = 1533	Same as original value.
target_throttle = 256	Same as original value. (Default throttle for all targets.)
lun_throttle = 64	Same as original value. (Default throttle for all LUNs.)
automap = 0	automap = 0 (persistence binding) automap = 1 (automapping)
Add these settings. (See “Modifying the HBA settings and binding the HBAs” on page 125 for procedures.)	target0_hba = “jnic146x0”;
	target0_wwpn = “controller_wwpn”
	target1_hba = “jnic146x1”;
	target1_wwpn = “controller_wwpn”

- You might need to run the `/etc/raid/bin/genjnicnf` reconfigure script from the Solaris shell.

```
# /etc/raid/bin/genjnicnf
```

- Set `portEnabled = 1`; only when you see JNI cards entering non-participating mode in the `/var/adm/messages` file. Under that condition:
  1. Set `FcPortCfgEnabled = 1`;
  2. Restart the host.
  3. Set `FcPortCfgEnabled = 0`;
  4. Restart the host again.

When you have done so, check `/var/adm/messages` to be sure that it sets the JNI cards to Fabric or Loop mode.

## Configuration settings for FCI-1063

This JNI HBA (FCI-1063) is supported *only* in configurations with DS4000 controller firmware versions 05.4x.xx.xx, or earlier.

**Important:** For all settings that are listed in Table 22, you must uncomment the line. This is true for both default settings and for settings that you must change.

For more information about setting the attributes for JNI HBAs, see “Modifying the HBA settings and binding the HBAs” on page 125.

Table 22. Configuration settings for FCI-1063

Original value	New value
scsi_initiator_id = 0x7d	Same as original value.
fca_nport = 0;	fca_nport = 1 (for the fabric) / fca_nport = 0 (for the loop)
public_loop = 0	Same as original value.
target_controllers = 126	Same as original value.
ip_disable = 1;	Same as original value.
ip_compliant = 0	Same as original value.
qfull_retry_interval = 0	Same as original value.
qfull_retry_interval = 1000	Same as original value (in milliseconds)
failover = 30;	failover = 60 (in seconds)
failover_extension = 0	Same as original value.
recovery_attempts = 5	Same as original value.
class2_enable = 0	Same as original value.
fca_heartbeat = 0	Same as original value.
reset_glm = 0	Same as original value.
timeout_reset_enable = 0	Same as original value.
busy_retry_delay = 100;	Same as original value. (in milliseconds)
link_recovery_delay = 1000;	Same as original value. (in milliseconds)
scsi_probe_delay = 500;	scsi_probe_delay = 5000 (in milliseconds; 10 milliseconds resolution)
def_hba_binding = "fca-pci*";	def_hba_binding = "nonjni"; (for binding) def_hba_binding = "fcaw"; (for non-binding)
def_wwnn_binding = "\$xxxxxx"	def_wwnn_binding = "xxxxxx"
def_wwpn_binding = "\$xxxxxx"	Same as the original entry.
fca_verbose = 1	Same as the original entry.
Will be added by reconfigure script	name="fca-pci" parent="physical path" unit-address="#"
Will be added by reconfigure script	target0_hba="fca-pci0" target0_wwpn="controller wwpn";
Will be added by reconfigure script	name="fca-pci" parent="physical path" unit-address="#"
Will be added by reconfigure script	target0_hba="fca-pci1" target0_wwpn="controller wwpn";

**Note:** You might need to run the `/etc/raid/bin/genjnicnf` reconfigure script from the Solaris shell.

```
# /etc/raid/bin/genjnicnf
```

## Configuration settings for FC64-1063

This JNI HBA (FC64-1063) is supported *only* in configurations with DS4000 controller firmware versions 05.4x.xx.xx, or earlier.

**Important:** For all settings that are listed in Table 23, you must uncomment the line. This is true for both default settings and for settings that you must change.

For more information about setting the attributes for JNI HBAs, see “Modifying the HBA settings and binding the HBAs” on page 125.

Table 23. Configuration settings for FC64-1063

Original value	New value
fca_nport = 0;	fca_nport =1;
ip_disable = 0;	ip_disable=1;
failover = 0;	failover =30;
busy_retry_delay = 5000;	busy_retry_delay = 5000;
link_recovery_delay = 1000;	link_recovery_delay = 1000;
scsi_probe_delay = 5000;	scsi_probe_delay = 5000;
def_hba_binding = “fcaw*”;	Direct attached configurations: def_hba_binding = “fcaw*”;  SAN-attached configurations: def_hba_binding = “nonJNI”;
def_wwnn_binding = “\$xxxxxx”	def_wwnn_bindindef_hba_binding = “nonjni”; g = “xxxxxx”
def_wwnn_binding = “\$xxxxxx”	Same as the original entry.
Will be added by reconfigure script	name=“fcaw” parent=“<physical path>”unit-address=“<#>”
Will be added by reconfigure script	target0_hba=“fcaw0” target0_wwpn=“<controller_wwpn>”;
Will be added by reconfigure script	name=“fcaw” parent=“<physical path>”unit-address=“<#>”
Will be added by reconfigure script	target0_hba=“fcaw0” target0_wwpn= “<controller_wwpn>”;

**Note:** You might need to run the `/etc/raid/bin/gen SCSIconf` reconfigure script from the shell prompt.

```
# /etc/raid/bin/gen SCSIconf
```

## QLogic HBA card settings

The QLogic cards are not plug-and-play with autoconfiguration. Instead, you need to change the settings or bindings, as described in Table 24.

**Note:** In Table 24, the HBA is identified as **hba0**. However, you need to modify the settings on both QLogic HBA cards: **hba0** and **hba1**.

When you modify the settings on **hba1** use the same values that are listed in the table, but change all instances of **hba0** to **hba1**, as shown in the following example:

HBA card	Original value	New value
<b>hba0</b>	hba0-execution-throttle=16;	hba0-execution-throttle=255;
<b>hba1</b>	hba1-execution-throttle=16;	hba1-execution-throttle=255;

In the vi Editor, uncomment and modify the loop attributes of each QLogic HBA card, using the values described in Table 24.

For more information about setting the attributes for QLogic HBAs, see “Modifying the QLogic HBA settings” on page 134.

Table 24. Configuration settings for QL2342

Original value	New value	Comments
max-frame-length=2048;	max-frame-length=2048	Use the default.
execution-throttle=16;	execution-throttle=255;	Change.
login-retry-count=8;	login-retry-count=30;	Change.
enable-adapter-hard-loop-ID=0;	enable-adapter-hard-loop-ID=1;	Change.
adapter-hard-loop-ID=0;	adapter-hard-loop-ID=0;	Needs to be a unique number.
enable-LIP-reset=0;	enable-LIP-reset=0;	Use the default.
hba0-enable-LIP-full-login=1;	hba0-enable-LIP-full-login=1;	Use the default.
enable-target-reset=0;	enable-target-reset=0;	Use the default.
reset-delay=5	reset-delay=8	Change.
port-down-retry-count=8;	port-down-retry-count=70;	Change.
maximum-luns-per-target=8;	maximum-luns-per-target=0;	Change.
connection-options=2;	connection-options=2;	Use the default.
fc-tape=1;	fc-tape=0;	Change.
loop-reset-delay = 5;	loop-reset-delay = 8;	Change.
> gbyte-addressing = disabled;	> gbyte-addressing = enabled;	Change.
link-down-timeout = 30;	link-down-timeout = 60;	Change.

---

## Appendix C. Downloading ESM firmware and drive firmware

The information in this appendix describes how to download current ESM firmware to a DS4000 EXP storage expansion enclosure and current drive firmware to a DS4000 storage subsystem, using the following procedures:

- “Verifying and downloading ESM firmware”
- “Downloading drive firmware” on page 232

---

### Verifying and downloading ESM firmware

This section describes how to verify current ESM firmware levels and how to download ESM firmware to an DS4000 EXP storage expansion enclosure, using the following procedures:

- “Verifying current ESM firmware version”
- “Downloading ESM firmware” on page 230
- “Automatic ESM firmware synchronization” on page 232

**Important:** If you are using DS4000 controller firmware version 05.41.xx.xx or 05.42.xx.xx with the EXP100, the EXP100 ESM firmware must be at version 955x or higher. However, you cannot upgrade the EXP100 firmware from 953x to 955x.

Before proceeding, see the *IBM TotalStorage DS4000 EXP100 Storage Expansion Enclosure Installation and User's Guide* or see the readme for controller firmware version 05.42.xx.xx at the following Web site:

[www-1.ibm.com/servers/storage/support/disk/](http://www-1.ibm.com/servers/storage/support/disk/)

Click the link for **DS4100 (FASiT100)**. When the page opens, click the Download tab, then follow the links to the readmes.

### Verifying current ESM firmware version

Choose one of the following methods to determine the storage expansion enclosure's ESM firmware version, using DS4000 Storage Manager.

- **Method One:**

1. In the Subsystem Management window, click **Storage Subsystem → View Profile**. The Storage Subsystem Profile window opens.
2. Select the **Enclosures** tab and scroll through the Profile For Storage Subsystem panel to locate the ESM card firmware version information.

**Tip:** The Profile for Storage Subsystem panel contains all the profile information for the entire subsystem. Therefore, it might be necessary to scroll through a large amount of information to locate the ESM firmware version information.

- **Method Two:**

1. In the Physical View panel of the Subsystem Management window, click **Advanced → Maintenance → Download → ESM firmware**. The Download Environmental (ESM) Card Firmware window opens.
2. In the Download Environmental (ESM) Card Firmware window, locate the firmware version of each ESM in the drive enclosure.

**Tip:** Each enclosure has two ESM cards: A and B.

## Downloading ESM firmware

To find the latest versions of ESM firmware files that you need to download, see the most recent DS4000 readme file, which is located at the following Web site:

[www-1.ibm.com/servers/storage/support/disk/](http://www-1.ibm.com/servers/storage/support/disk/)

Click the link for your storage subsystem. When the page opens, click the Download tab, then follow the links to the readmes.

Complete the following procedures to download ESM firmware:

- “Preparing for the download”
- “Downloading the ESM firmware” on page 231

### Preparing for the download

To prepare for the download, review and complete all of the steps in this section before you start the download procedures that are listed in “Downloading the ESM firmware” on page 231.

**Before you begin:** Ensure that you have the latest version of the DS4000 Storage Manager installed on your DS4000 management station. You can download the latest version from the following IBM DS4000 support Web site:

[www-1.ibm.com/servers/storage/support/disk/](http://www-1.ibm.com/servers/storage/support/disk/)

Complete the following steps to prepare your system for the firmware download:

#### 1. Backup your logical drives.

Complete a full backup of all logical drives that are defined in the DS4000 storage subsystem.

#### 2. Save the storage subsystem profile.

Saving a profile is necessary in order to restore a storage subsystem configuration in the event of a catastrophic failure. Save your storage subsystem profile by completing the following steps:

1. In the Subsystem Management Menu, select **Storage Subsystem** → **View** → **Profile**. The Storage Subsystem Profile window opens.
2. In the Storage Subsystem Profile window, click **Save As**. The Save Profile window opens.
3. In the Save Profile window, select or enter the file directory and file name. Click **Save** to save the profile. The Save Profile window closes.

**Attention:** Do *not* store DS4000 Storage Subsystem profiles in the same location as the logical drives that are defined on your DS4000 Storage Subsystem. If you do, and the logical drives fail during the subsequent migration, you will lose data.

4. Click **Close** to close the Storage Subsystem Profile window.

#### 3. Verify current EXP ESM status.

In the DS4000 Storage Manager Subsystem Management window, verify that all ESMs in the configuration that you are upgrading are in the Optimal state, and there are not any lost drive-path redundancy errors. Correct any problems using the suggested instructions in the DS4000 Storage Manager Recovery Guru window.



To verify, either click the **Recovery Guru** icon in the Subsystem Management window, or click the **Enclosure Status** icon in each enclosure with the red X mark overlay, as displayed in the Physical View.

## 5. Determine whether you need to stop I/O.

Downloading firmware without stopping I/O is referred to as *concurrent download*. Concurrent ESM firmware download is supported with the following conditions:

- You can only use concurrent ESM firmware download with fibre channel storage expansion enclosures. With SATA storage expansion enclosures, you must stop I/O before downloading ESM firmware.
- You must download the ESM firmware to one storage expansion enclosure at a time. If you want to download ESM firmware to multiple storage expansion enclosures at the same time, you must stop I/O before downloading.
- Ensure that concurrent ESM download is supported with the new ESM firmware package by checking its readme file before you download the package. If concurrent download is not supported with the new firmware, you must stop I/O before downloading the firmware.

When you are done, continue to “Downloading the ESM firmware.”

## Downloading the ESM firmware

**Before you begin:** To find the latest versions of ESM firmware files that you need to download, see the most recent DS4000 readme file, which is located at the following Web site:

[www-1.ibm.com/servers/storage/support/disk/](http://www-1.ibm.com/servers/storage/support/disk/)

Click the link for your storage subsystem. When the page opens, click the Download tab, then follow the links to the readmes.

Complete the following steps to download the ESM firmware to the DS4000 EXP storage expansion enclosure:

1. In the Subsystem Management window, select **Advanced** → **Maintenance** → **Download** → **ESM firmware**. The Download Environmental (ESM) Card Firmware window opens.
2. In the Download Environmental (ESM) Card Firmware window, select the storage expansion enclosure to be updated with new firmware, and then click **Browse** to open the Select Environmental (ESM) Card Firmware File window.

**Attention:** You can download the ESM firmware to several storage expansion enclosures at the same time by selecting more than one storage expansion enclosure – however, you must stop all I/O before performing the download. If you do not want to stop I/O, then download the ESM firmware to each storage expansion enclosure, one at a time. Detailed information about download times can be found in the readme for your host OS. See “Readme files and concepts” on page 1.

3. In the Select Environmental (ESM) Card Firmware File window, select the directory that contains the ESM firmware file, then select the name of the ESM firmware file. Click **OK** to close the window and continue.

**Note:** You might need to select All Files (\*.\*) in the “Files of type” pull-down menu to display the correct file name for selection. If you do, then a warning window opens. Click **OK** when the warning window opens.

4. In the Download Environmental (ESM) Card Firmware window, click **Start**. When the Confirm Download window opens, type yes and click **OK**. The ESM firmware download begins. During the download, the status field of the Download Environmental (ESM) Card Firmware window displays the progress of each enclosure.

When the status field of each enclosure displays a status of Complete, the ESM firmware download is complete.

## Automatic ESM firmware synchronization

When you install a new ESM into an existing storage expansion enclosure in a DS4000 storage subsystem that supports automatic ESM firmware synchronization, the firmware in the new ESM is automatically synchronized with the firmware in the existing ESM. This resolves any ESM firmware mismatch conditions automatically.

To enable automatic ESM firmware synchronization, ensure that your system meets the following requirements:

- The Storage Manager Event Monitor must be installed and running
- The DS4000 storage subsystem must be defined in the Enterprise Management window of the Storage Manager client (SMclient)

**Note:** Storage Manager 10.10 currently supports automatic ESM firmware synchronization with EXP810 storage expansion enclosures only. Contact IBM for information about support for other types of storage expansion enclosures in the future. To correct ESM firmware mismatch conditions in storage expansion enclosures without automatic ESM firmware synchronization support, you must download the correct ESM firmware file by using the ESM firmware download menu function in the SMclient Subsystem Management window.

---

## Downloading drive firmware

This section provides instructions for downloading DS4000 drive firmware. See the online help for additional information.

### **Important:**

1. IBM supports firmware download with I/O, sometimes referred to as “concurrent firmware download.” This feature is not supported for drive firmware.
2. Before starting the drive firmware download process:
  - Stop all I/O activity before downloading drive firmware to a DS4000 Storage Subsystem.
  - Unmount the file systems on all logical drives accessing the drives that you select for firmware upgrade.
  - Complete a full backup of all data residing on the drives that you select for firmware upgrade.

## Downloading drive firmware with Storage Manager version 9.1x and higher

To download drive firmware for using DS4000 Storage Manager version, perform the following steps:

1. From the Enterprise Management window, select a storage subsystem.
2. On the Enterprise Management window's menu bar, click **Tools** → **Manage Storage Subsystem Device**. The Subsystem Management window opens.
3. On the Subsystem Management window's menu bar, click **Advanced** → **Maintenance** → **Download** → **Drive Firmware/Mode pages ...**. The Download Drive Firmware wizard window opens to the Introduction page. Read the instructions displayed and click **Next**.

**Note:** Storage Manager version 9.1x and higher offers you the option to download and update up to four different firmware file types simultaneously. Previous Storage Manager versions did not offer this capability.

4. Click **Browse** to locate the subsystem directory that contains the firmware that you plan to download.
5. Select the firmware file that you plan to download and click **OK**. The file appears listed in the "Selected Packages" window pane.
6. Select the firmware file for any additional drive types that you intend to download and click **OK**. Additional files appear listed in the "Selected Packages" window pane. A maximum total of four drive types is possible.
7. Click **Browse** to repeat step 6 until you have selected each firmware file that you plan to download.
8. When you have finished specifying the firmware packages for download, select **Next**.
9. The Select Drive window opens, containing two tabs, a **Compatible Drives** tab and an **Incompatible Drives** tab. The **Compatible Drives** tab contains a list of the drives compatible to the firmware package types that you selected. From that list, select the drives to which you plan to download the drive firmware that you selected in steps 6 and 7.

**Note:** The firmware that you propose to download should be listed on the **Compatible Drives** tab. If your particular drives' product ID matches the firmware type, however, and it is not listed as compatible on the tab, contact your IBM technical support representative for additional instructions.

10. Select the **Compatible Drives** tab.  
Press and hold the **Ctrl** key while using your mouse to select multiple drives individually, or press and hold the **Shift** key while using your mouse to select multiple drives listed in series. The compatible firmware that you selected in steps 5 and 6 will download to the drives that you select.
11. Click **Finish** to initiate download of the drive firmware to each compatible drive that you selected in step 9.
12. The Download Drive Firmware warning opens and prompts: "Do you want to continue?" Type **yes** and click **OK** to start the drive firmware download.
13. The Download Progress window opens. Do not intervene until the download process completes.
14. Every drive scheduled for firmware download will be designated as in progress until successful or failed.

**Note:** Complete the following two steps if you receive a failure.

- a. Click the **Save as** button to save the error log.
- b. On the Subsystem Management window menu bar, click **Advanced** → **Trouble Shooting** → **Open Event Log** and complete the following

tasks necessary to save the storage subsystem event log before contacting your IBM Service Representative and proceeding to step 15.

- 1) Click the **Select all** button.
- 2) Click **Save the Storage Subsystem Event Log**.

When the **Close** button appears active, the drive firmware download process is complete.

15. Click **Close** to exit the Download Progress window.
16. Use either of the following procedures to determine or verify what level of drive firmware resides on a particular drive:
  - Right-click that drive in the Logical/Physical View in the Subsystem Management window and click **Properties**. The associated drive firmware version will be listed in the drive properties table.
  - Click **Storage Subsystem → View Profile** in the Logical/Physical View of the Subsystem Management window.

## Downloading drive firmware with Storage Manager version 8.x

To download drive firmware for using DS4000 Storage Manager version 8.x, perform the following steps:

1. From the Enterprise Management window, select a storage subsystem.
2. Click **Tools → Manage Device**. The Subsystem Management window opens.
3. Click **Advanced → Download → Drive Firmware**. The Download Drive Firmware window opens. It presents a list of all installed drives.
4. From the list of all installed drives, select the drive to which you plan to download drive firmware.

Press and hold the **Ctrl** key while using your mouse to select multiple drives singly, or press and hold the **Shift** key while selecting multiple drives in series by using your mouse pointer.
5. Click **Browse** to identify the directory that contains the drive firmware that you intend to download.
6. Select the file containing the drive firmware that you intend to download.
7. Select **Start**. The Confirm Download window appears.
8. Type **yes** when the Confirm Download window prompts: Are you sure you want to continue?
9. The download begins and the Status window indicates progress. Do not intervene until the download process completes.
10. When the **Cancel** button appears active, the download process is complete. Press **Cancel** to close the Status window.
11. To determine or verify the level of drive firmware residing on a particular drive, click **View → Subsystem Profile** in the Logical/Physical View of the Subsystem Management window.

---

## Appendix D. Using the IBM System Storage DS4000 Controller Firmware Upgrade Tool

---

### IBM System Storage DS4000 Controller Firmware Upgrade Tool overview

**Caution:**

Before using the IBM System Storage DS4000 Controller Firmware Upgrade Tool to migrate to version 07.10, it is *extremely* important that all data for DS4800, DS4700, and DS4200s be completely backed up and that existing system configurations be saved. Once the tool has completed an upgrade, controllers *cannot* be returned to previous firmware version levels. The Controller Firmware Upgrade Tool is to be used *only* when migrating DS4800, DS4700, and DS4200 controllers *from* version 06.xx *to* version 07.10. This tool is not intended to replace, nor should be used to perform, standard upgrades for controller, ESM, or drive firmware. (To perform a standard controller, ESM, or drive firmware upgrade, please see Appendix C, “Downloading ESM firmware and drive firmware,” on page 229.

You must perform the upgrade offline. You should perform the overall installation of Storage Manager into an existing host environment online. For most failover drivers to take effect, you must reboot the host.

You must make sure that all devices have an Optimal status before you download firmware. You must also check the current firmware level.

**Attention: Potential loss of data access**—Make sure the firmware you download is compatible with the Storage Manager software that is installed on your storage system. If non-compatible firmware is downloaded, you might lose access to the drives in the storage system, so upgrade Storage Manager first.

Do not make changes to your configuration or remove drives or enclosures during the upgrade process.

For information about the current firmware versions, see “Readme files and concepts” on page 1 to find out how to access the most recent Storage Manager readme files on the Web.

---

### Checking the device health conditions

Perform the following steps to determine the health condition of your device.

1. From the Array Management Window in Storage Manager, right-click the storage system. The Storage Manager software establishes communication with each managed device and determines the current device status.

There are six possible status conditions:

- **Optimal**—Every component in the managed device is in the desired working condition.
- **Needs Attention**—A problem exists with the managed device that requires intervention to correct it.

- **Fixing**—A Needs Attention condition has been corrected, and the managed device is currently changing to an Optimal status.
  - **Unresponsive**—The storage management station cannot communicate with the device, or one controller or both controllers in the storage system.
  - **Contacting Device**—The management software is establishing contact with the device.
  - **Needs Upgrade**—The storage system is running a level of firmware that is no longer supported by the storage management software.
2. If the status is a Needs Attention status, write down the condition. Contact an IBM Technical Support representative for fault resolution.

**Note:** The Recovery Guru in the Storage Manager software also provides a detailed explanation of, and recovery procedures for, the conditions.

## Installing the upgrade tool

To install the upgrade tool, complete the following steps.

1. Open the SMFWUpgInstaller-xxx-10.10.A5.xx.bin installation file, according to your operating system procedures. The IBM System Storage DS4000 Controller Firmware Upgrade Tool installation window appears.
2. Click **Next**.
3. Accept the license agreement, and click **Next**.
4. Select the folder in which you want to install the tool, and click **Next**.
5. Click **Install**.
6. Click **Done**.

---

## Adding a storage subsystem

To add a storage subsystem using the upgrade tool, perform the following steps.

1. Click **Add**. The Select Addition Method window appears.
2. Select either **Automatic** or **Manual**.

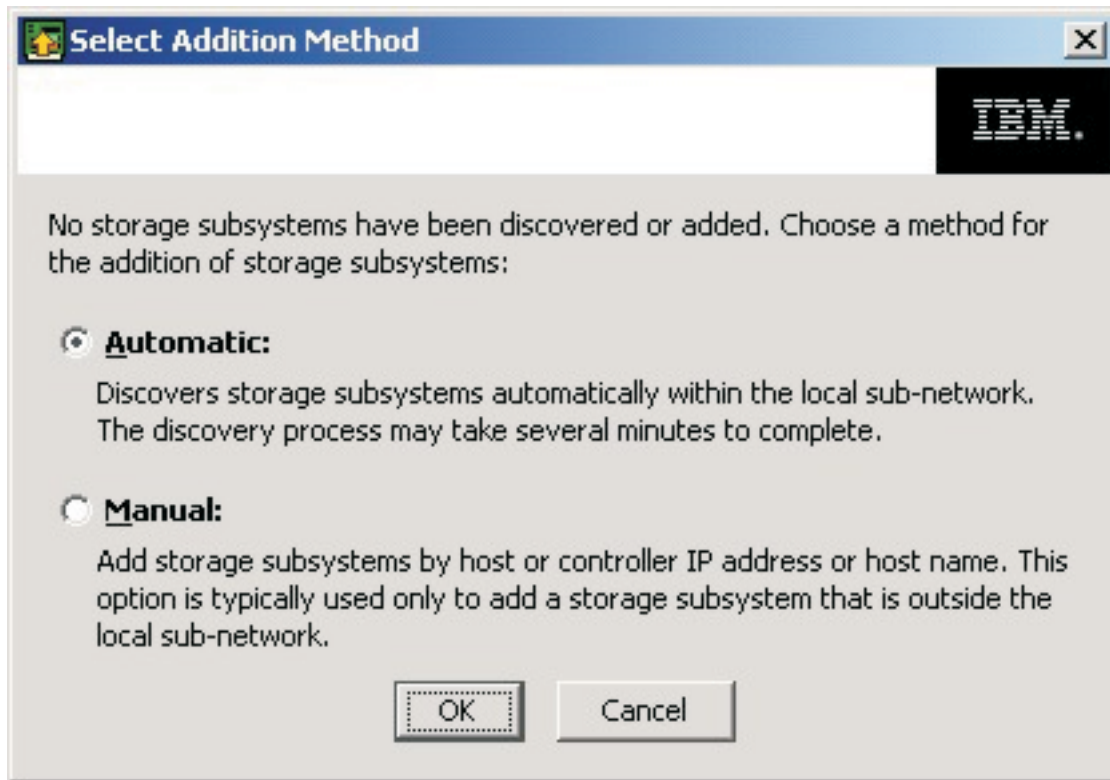

ds4k\_swut\_initial

Figure 32. Selection Addition Method window

3. Click **OK** to begin adding storage subsystems.
4. To see any issues with the storage system you added that might impede upgrading the firmware, click **View Log**.

---

## Downloading the firmware

To download the firmware, perform the following steps.

1. You need to first select the storage subsystem you want to activate to enable the download button, then Click **Download Firmware**. The Download Firmware window appears.

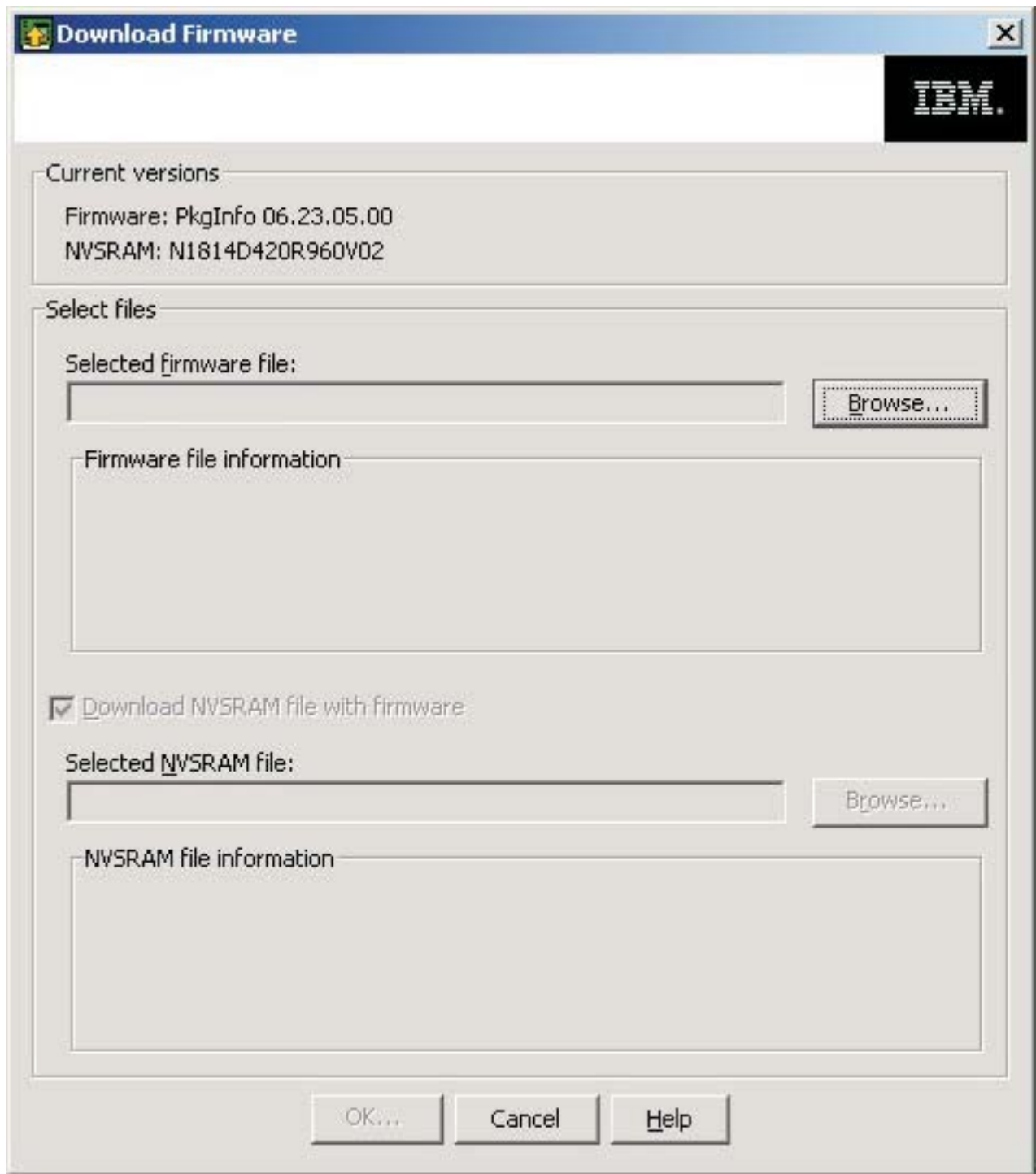

ds4k\_swut\_download

Figure 33. Download Firmware window

2. Select the controller firmware file that you want to download. Click **Browse** to choose the file from a directory on your computer or on your network.
3. Select the NVSRAM file you want to download. Click **Browse** to choose the file from a directory on your computer or on your network.



4. Click **OK**. The firmware starts to download. A status bar appears in the Controller Firmware Upgrade window.

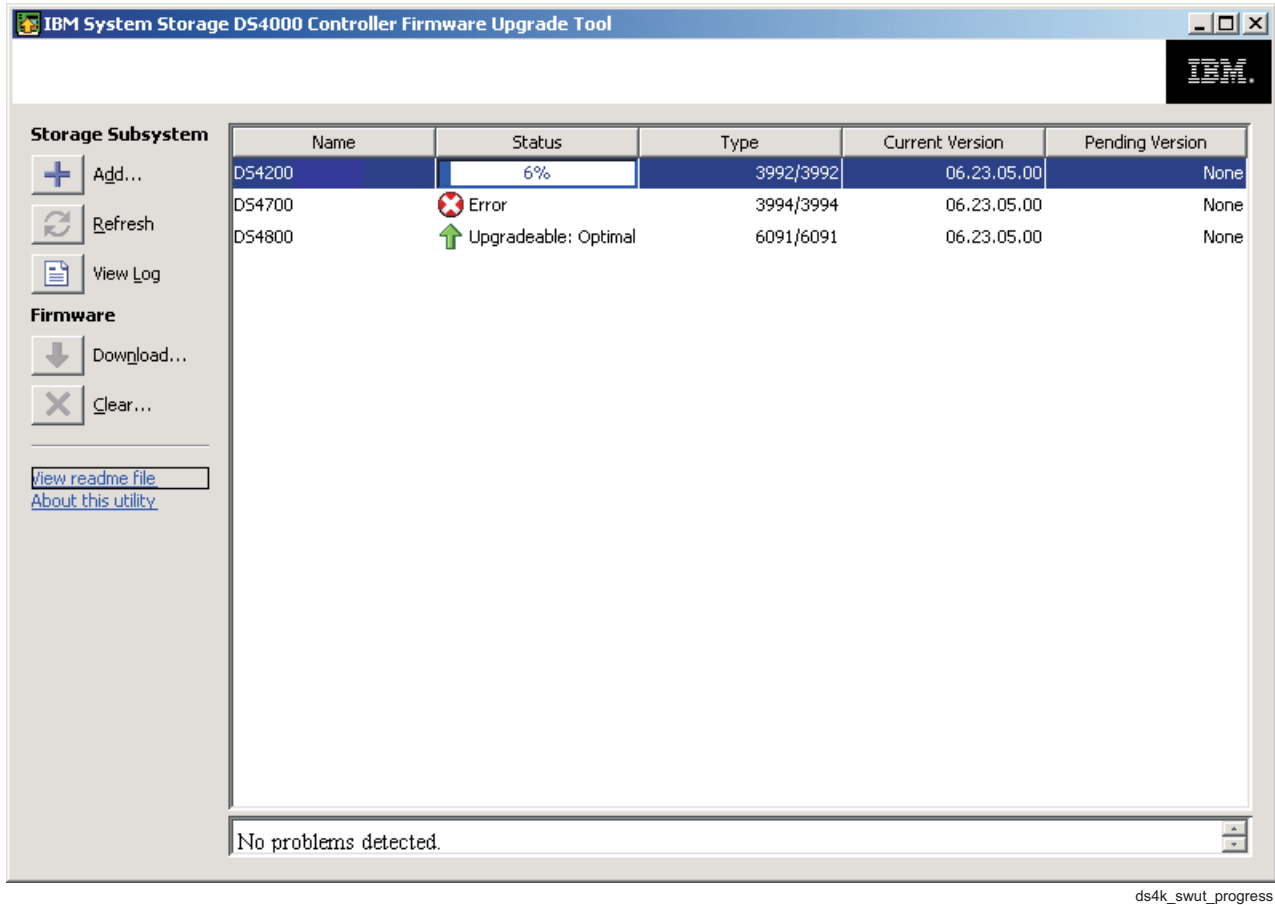
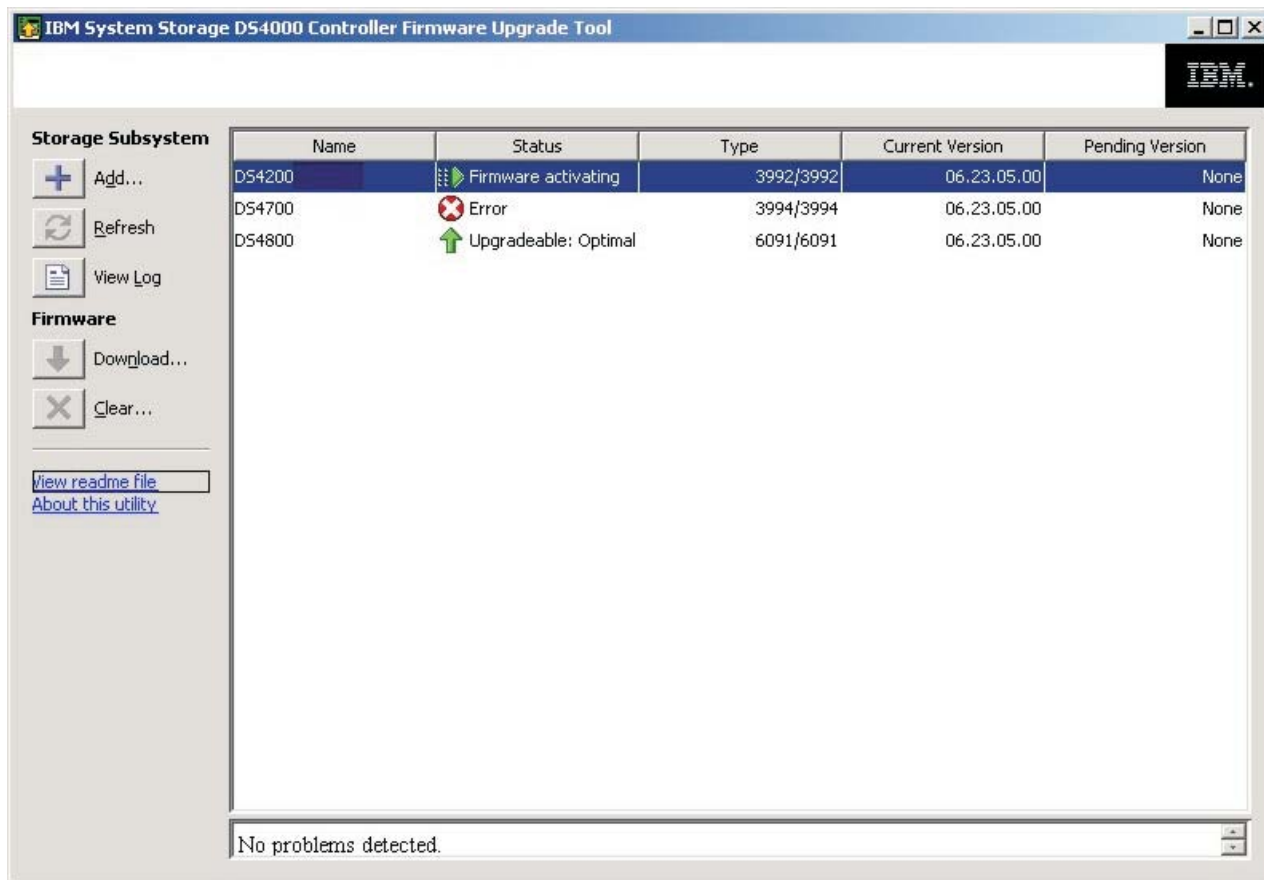

Figure 34. Download progress window

The firmware begins the activation process, and the status bar in the IBM System Storage DS4000 Controller Firmware Upgrade Tool window appears.



ds4k\_swut\_activate

Figure 35. Firmware activating window

## Viewing the IBM System Storage DS4000 Controller Firmware Upgrade Tool log file

If you encounter any problems updating your firmware, perform the following steps to view the log file.

1. Click **View Log**. The View Log window appears. This log documents any issues with the storage system that might prevent you from updating the firmware.
2. If any issues are documented in the log, correct those issues before you try to download the firmware.

---

## Appendix E. Limitations

This sections in this appendix contain descriptions of potential problems and ways to work around them.

---

### AIX

The following information might apply to your storage subsystem.

1. Storage Manager prompts you for a password if all hard disk drives are removed from the storage subsystem. After removing all drives from a storage subsystem (or not powering on drives and only the controller), the IBM DS4000 Storage Manager software will prompt you for a password when trying to start the software or trying to perform protected operations. Any password entered will fail.  
Password information is stored on a reserved area of each hard disk drive on the storage subsystem. Each drive stores a mirrored copy of the password data. When there are no drives in the storage subsystem, the storage management software does not find the password data when you attempt password protected operations. Add one drive to the storage subsystem and retry the operation.
2. Auto LUN/Array Transfer is not supported. If a controller fails over arrays to the alternate controller and the failed controller is replaced and brought back online, the arrays do not automatically transfer to the preferred controller. This must be done manually by redistributing arrays.
3. If the controller in the IBM DS4000 Storage Server with firmware 05.4x.xx.xx is connected to a SAN with more than 256 host connections per controller port, that can log into the controllers, one must either use the switch zoning function or rearrange the SAN connections so that only the maximum number of host connections can be seen and log into the controller.
4. Dynamically changing the cache read ahead multiplier setting via the storage manager client may result in an error message indicating the operation has failed. Despite the error message, the request to change the cache read ahead multiplier will remain queued to the controllers and will eventually complete when I/O activity to the storage subsystem has subsided. In order to avoid the error message and any delays in the cache read ahead multiplier value changing, it is recommended to change the cache read ahead multiplier when the subsystem is in a quiesced state.

---

### HP-UX

The following information might apply to your storage subsystem.

1. If you are upgrading controller firmware in IBM FASTT500 storage controller with 512MB Cache, you will have to stop I/O and reboot both controllers before upgrading firmware followed by NVSRAM. You can reboot the controllers either by power cycling the storage subsystem or by pressing the Reset button on both controllers. The Reset button is located on the right of the indicator lights in the opening on the front of each controller unit.

To determine Storage Controller cache level, perform the following:

- a. On a storage management station start the client software and select a storage subsystem.
- b. Select **Tools** → **Manage Device** to open the Subsystem Management Window

- c. Highlight the Storage Subsystem that you are upgrading and then select **Storage Subsystem → Profile**. It may take a little time for it to create the Storage Subsystem profile.
- d. Under the Controllers heading is an entry that displays information similar to the following example:

Cache/processor size (MB): 256/32

If this setting is listed as 512/32 you will need to arrange to perform this upgrade procedure at a time that you can stop I/O to the Storage Subsystem in order to ensure a successful firmware download and installation.

2. Storage Manager prompts you for a password if all hard disk drives are removed from the storage subsystem. After removing all drives from a storage subsystem (or not powering on drives and only the controller), the IBM DS4000 Storage Manager software will prompt you for a password when trying to start the software or trying to perform protected operations. Any password entered will fail.

Password information is stored on a reserved area of each hard disk drive on the storage subsystem. Each drive stores a mirrored copy of the password data. When there are no drives in the storage subsystem, the storage management software does not find the password data when you attempt password protected operations. Add one drive to the storage subsystem and retry the operation.

Since the RAID controller unit should not be powered on until the expansion units are attached and powered on, this should be done by powering off the RAID controller unit, properly attaching all expansion units (with drives installed), to the RAID controller unit and powering them on, and then powering the RAID controller unit back on. At this point the storage subsystems can be rediscovered and managed using the IBM DS4000 Storage Manager 8.3x software.
3. Display issues when using 256 color settings. A brownish hash pattern is displayed on the windows and in online help when running in 256 color mode. Run the Storage Manager 8 application in a higher display mode.
4. If you get "Error 21—The Operation cannot complete because a ... is in progress" error when you issue a Subsystem Management command from the IBM DS4000 Storage Manager Client, the command may be cached. If the command is cached, the IBM DS4000 Storage Manager Client will run the command as soon as the controller resources are available. Wait for at least ten minutes and check to see whether the command has been run. If not, reattempt the command.
5. The IBM FAStT500, DS4400 or DS4500 Storage Server hardware and software is designed to have redundant paths from the host system to ensure the availability of storage. However, it is possible to connect a single host adapter from the host system to one of the controller minihubs and then connect this minihub to the minihub of the other controller.

This configuration will create a FC-AL loop between the host adapter and the two IBM FAStT500, DS4400 or DS4500 Storage Server controllers and no redundant path to the host system. When you connect the two minihubs together, always connect the IN port of one minihub to the OUT port of the other minihub or vice versa. Do not connect the IN port of one to the IN port of the other minihub or the OUT port of one minihub to the OUT port of the other minihub.

6. DS4000 now supports 127 LUNs on HP-UX. However, the number of actual LUNs might vary from HP-UX host to host. The number of LUNs supported varies depending on the number of processors and memory.
7. Dynamically changing the cache read ahead multiplier setting via the storage manager client may result in an error message indicating the operation has failed. Despite the error message, the request to change the cache read ahead multiplier will remain queued to the controllers and will eventually complete when I/O activity to the storage subsystem has subsided. In order to avoid the error message and any delays in the cache read ahead multiplier value changing, it is recommended that you change the cache read ahead multiplier when the subsystem is in a quiesced state.

---

## Solaris

1. Upgrading FAStT500 with 512MB Cache. If you are upgrading controller firmware in IBM FAStT500 storage controller (MT 3552), you will have to stop I/O and reboot both controllers before upgrading NVSRAM followed by Firmware. You can reboot the controller by either power cycle the storage subsystem or by pressing the Reset button on both controllers. The Reset button is located on the right of the indicator lights in the opening on the front of each controller unit.

To determine Storage Controller cache level, perform the following:

- a. On a storage management station start the client software and select a storage subsystem.
- b. Select **Tools** → **Manage Device** to open the Subsystem Management Window
- c. Highlight the Storage Subsystem that you are upgrading and then select **Storage Subsystem** → **Profile**. It may take a little time for it to create the Storage Subsystem profile.
- d. Under the Controllers heading is an entry that displays information similar to the following example:

```
Cache/processor size (MB): 256/32
```

If this setting is listed as 512/32 you will need to arrange to perform this upgrade procedure at a time that you can stop I/O to the Storage Subsystem in order to ensure a successful firmware download and installation.

2. Storage Manager prompts you for a password if all hard disk drives are removed from the storage subsystem. After removing all drives from a storage subsystem (or not powering on drives and only the controller), the IBM DS4000 Storage Manager software will prompt you for a password when trying to start the software or trying to perform protected operations. Any password entered will fail.

Password information is stored on a reserved area of each hard disk drive on the storage subsystem. Each drive stores a mirrored copy of the password data. When there are no drives in the storage subsystem, the storage management software does not find the password data when you attempt password protected operations. Add one drive to the storage subsystem and retry the operation.

Since the RAID controller unit should not be powered on until the expansion units are attached and powered on, this should be done by powering off the RAID controller unit, properly attaching all expansion units (with drives installed), to the RAID controller unit and powering them on, and then powering the RAID

controller unit back on. At this point the storage subsystems can be rediscovered and managed using the IBM DS4000 Storage Manager 8.3x software.

3. Auto LUN/Array Transfer is not supported. If a controller fails over arrays to the alternate controller and the failed controller is replaced and brought back online, the arrays do not automatically transfer to the preferred controller. This must be done manually by redistributing arrays.
4. Display issues when using 256 color settings. A brownish hash pattern is displayed on the windows and in online help when running in 256 color mode. Run the Storage Manager 8 application in a higher display mode.
5. If you get "Error 21—The Operation cannot complete because a ... is in progress" error when you issue a Subsystem Management command from the IBM DS4000 Storage Manager Client, the command may be cached. If the command is cached, the IBM DS4000 Storage Manager Client will run the command as soon as the controller resources are available. Wait for at least ten minutes and check to see whether the command has been run. If not, reattempt the command.
6. The IBM FAStT500, DS4400 or DS4500 Storage Server hardware and software is designed to have redundant paths from the host system to ensure the availability of storage. However, it is possible to connect a single host adapter from the host system to one of the controller minihubs and then connect this minihub to the minihub of the other controller.

This configuration will create a FC-AL loop between the host adapter and the two IBM FAStT500, DS4400 or DS4500 Storage Server controllers and no redundant path to the host system. When you connect the two minihubs together, always connect the IN port of one minihub to the OUT port of the other minihub or vice versa. Do not connect the IN port of one to the IN port of the other minihub or the OUT port of one minihub to the OUT port of the other minihub.

## Appendix F. Connecting HBAs in a FC switch environment

When connecting fibre channel host bus adapters in host servers to DS4000 Storage Server host ports in a fibre channel switch environment, IBM recommends that you establish one-to-one zones between the HBA and DS4000 host ports.

For instructions on how to set up a zone inside a fibre channel switch, see your fibre channel switch's installation and user's guide.

**Note:** You can find links to switch documentation at the following Web site:

[www.ibm.com/servers/storage/support/san/index.html](http://www.ibm.com/servers/storage/support/san/index.html)

Figure 36 illustrates a sample configuration consisting of two host servers, each with two fibre channel host bus adapters, each of which are connected to a DS4000 Storage Server host port through a fibre channel switch.

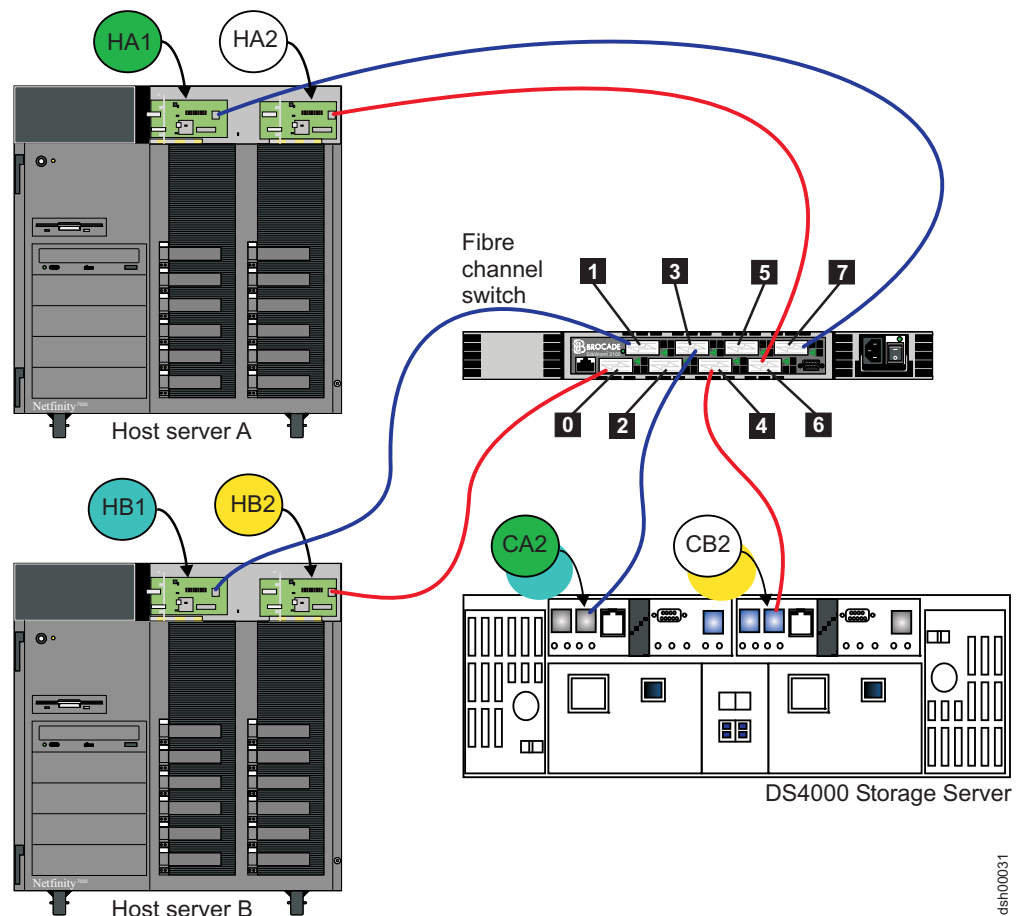

Figure 36. Fibre channel fabric switch environment connecting host servers to a DS4000 Storage Server

**Legend:**

<b>Controller</b>	<b>Zone</b>	<b>Port</b>	<b>Connection to and from</b>	<b>Description</b>
A	1	<b>7</b> <b>3</b>	HA1 CA2	This will zone the fibre channel HBA port HA1 in host server A to port 2 of the DS4000 Storage Server controller A.
	2	<b>1</b> <b>3</b>	HB1 CA2	This will zone the fibre channel HBA port HB1 in host server B to port 2 of the DS4000 Storage Server controller A.
B	3	<b>6</b> <b>4</b>	HA2 CB2	This will zone the fibre channel HBA port HA2 in host server A to port 2 of the DS4000 Storage Server controller B.
	4	<b>0</b> <b>4</b>	HB2 CB2	This will zone the fibre channel HBA port HB2 in host server B to port 2 of the DS4000 Storage Server controller B.



---

## Appendix G. DS4000 Diagnostic Data Capture (DDC)

---

### DDC information

Under rare circumstances an internal controller error can force a routine to perform a function referred to as a DDC or Diagnostic Data Capture. When this has occurred, if you open the Enterprise Management window you will notice a red stop sign next to the name of the storage that has the error (is in a non-optimal state). Click on that storage to bring up the Subsystem Management window. You can then click on the Recovery Guru which will show what the issue is, or you can check in the MEL (DS4000 Storage Manager Major Events Log), where a critical event will be posted. See “DDC MEL events” on page 249.

### DDC function implementation

In order to assist IBM support in collecting data for troubleshooting certain unusual events in controller firmware, the Diagnostic Data Capture (DDC) function was implemented in the latest controller firmware version of the following DS4000 storage subsystem controller firmware versions:

- 07.10.xx.xx
- 06.23.xx.xx or greater
- 06.19.xx.xx
- 06.16.xx.xx
- 06.15.24.xx or higher
- 06.12.27.xx or higher

**Note:** This function is not implemented with controller firmware code versions that are less than 06.12.27.xx level.

#### How Diagnostic Data Capture works

When the DDC function is implemented, the DS4000 storage subsystem status will change from *Optimal* to *Needs Attention due to DDC*. This will occur whenever the controllers in the DS4000 subsystem detect unusual events like Master abort (due to a bad address accessed by the fibre channel chip resulting in a PCI bus error), when the controller is not able to process host I/O requests for an extended period of time (several minutes), when there is destination device number registry corruption, an EDC error is returned by the disk drives, a Quiescence failure for the Logical Drive owned by the alternate controller. or corruption in records related to Storage Partition Management. Once the Needs Attention due to DDC flag is set, it will be persistent across the power-cycle and controller reboot, provided the controller cache batteries are sufficiently charged. In addition, data reflecting the state of the subsystem controllers at the moment in time that the unusual event occurred will be collected and saved until it is retrieved by the user. To clear the Needs Attention due to DDC flag and to retrieve the saved diagnostic data, see “Recovery steps” on page 248.

Because the current DDC function implementation will hold the DDC data for only one unusual event at a time until the DDC data is saved, the SMcli commands must be performed as soon as possible whenever the Needs Attention due to DDC error occurs. This is so the controllers can be ready for capturing data for any other unusual events. Until the diagnostic data is saved and the Needs Attention due to DDC flag is cleared, any occurrences of other unusual events will not trigger the controller to capture diagnostic data for those events. An unusual event is considered a candidate for a DDC trigger if a previous DDC trigger is at least 48

hours old or the user has successfully retrieved the previous DDC information. In addition, DDC information is *only* available in the case of a controller that is online. A controller that is in service or lock down mode will not trigger a DDC event. After collecting the DDC data, contact IBM support to report the problem and to enlist assistance in troubleshooting the condition that triggered the event.

## Recovery steps

Follow steps 1–6 to complete the DDC recovery process.

1. Open either the Script Editor from the Enterprise Management Window (EMW), or the Command Line Interface (CLI).

**Note:** Refer to the EMW online help for more information on the syntax of these commands.

2.

Table 25. Recovery Step 2

If...	Then...
You want to save the diagnostic data	Go to Step 3.
You do NOT want to save the diagnostic data	Go to Step 5.

3. Execute the following SMcli command:

```
save storageSubsystem diagnosticData file="filename ";
```

Where *filename* is the location and name of the file that will be saved. The file will be formatted as a .zip file.

**Note:** Currently, the *esm* parameter of the command syntax is not supported.

4.

Table 26. Recovery Step 4

If...	Then...	
No error was returned	Go to Step 6.	
An error was returned	If...	Then...
	The error message indicates that there was a problem saving the data	Wait 2 minutes and then restart Step 3.
	The error message indicates that there was a problem resetting the data	Wait 2 minutes and then go to Step 5.

5. Execute the following SMcli command:

```
reset storageSubsystem diagnosticData;
```

Table 27. Recovery Step 5

If...	Then...
No error was returned	Go to step 6.
An error was returned	Wait 2 minutes and then execute the command again. The controllers may need additional time to update status. Note that you may also get an error if the diagnostic data status has already been reset.  Go to step 6.

6. Select Recheck to rerun the Recovery Guru. The failure should no longer appear in the Summary area.

After this process has been successfully completed, the DDC message will automatically be removed, and a recheck of the Recovery Guru will show no entries for DDC capture. If for some reason the data has not been removed, the Recovery Guru gives an example of how to clear the DDC information without saving the data. Follow the above procedure using the following command in the script editor:

```
reset storageSubsystem diagnosticData;
```

---

## DDC MEL events

When the Diagnostic Data Capture action is triggered by an unusual event, one or more of the following events will be posted in the storage subsystems event logs, depending on the user actions.

1. **Event number: 0x6900.**

Description: Diagnostic Data is available.

Priority: Critical.

This is logged when an unusual controller event triggers the DDC function to store Diagnostic Data.

2. **Event number: 0x6901.**

Description: Diagnostic Data retrieval operation started.

Priority: Informational.

This is logged when the user runs the SMcli command to retrieve and save the Diagnostic Data, as described in step 3 of the “Recovery steps” on page 248.

3. **Event number: 0x6902.**

Description: Diagnostic Data retrieval operation completed.

Priority: Informational.

This is logged when the Diagnostic Data retrieval and save completes.

4. **Event number: 0x6903.**

Description: Diagnostic Data Needs Attention status/flag cleared.

Priority: Informational.

This is logged when the user resets the Needs Attention flag due to DDC, using the SMcli command or Diagnostic Data retrieval and save completes successfully when initiated by the user executing the save storageSubsystem diagnosticData SMcli command.



## Appendix H. Accessibility

This section provides information about alternate keyboard navigation, which is a DS4000 Storage Manager accessibility feature. Accessibility features help a user who has a physical disability, such as restricted mobility or limited vision, to use software products successfully.

By using the alternate keyboard operations that are described in this section, you can use keys or key combinations to perform Storage Manager tasks and initiate many menu actions that can also be done with a mouse.

**Note:** In addition to the keyboard operations that are described in this section, the DS4000 Storage Manager version 9.14 - 10.10 (and later) software installation packages for Windows include a screen reader software interface.

To enable the screen reader, select Custom Installation when using the installation wizard to install Storage Manager 9.14 - 10.10 (or later) on a Windows host/management station. Then, in the Select Product Features window, select Java Access Bridge in addition to the other required host software components.

Table 28 defines the keyboard operations that enable you to navigate, select, or activate user interface components. The following terms are used in the table:

- *Navigate* means to move the input focus from one user interface component to another.
- *Select* means to choose one or more components, typically for a subsequent action.
- *Activate* means to carry out the action of a particular component.

**Note:** In general, navigation between components requires the following keys:

- **Tab** - Moves keyboard focus to the next component or to the first member of the next group of components
- **Shift-Tab** - Moves keyboard focus to the previous component or to the first component in the previous group of components
- **Arrow keys** - Move keyboard focus within the individual components of a group of components

Table 28. DS4000 Storage Manager alternate keyboard operations

Short cut	Action
F1	Open the Help.
F10	Move keyboard focus to main menu bar and post first menu; use the arrow keys to navigate through the available options.
Alt+F4	Close the management window.
Alt+F6	Move keyboard focus between dialogs (non-modal) and between management windows.

Table 28. DS4000 Storage Manager alternate keyboard operations (continued)

Short cut	Action
Alt+ underlined letter	<p>Access menu items, buttons, and other interface components by using the keys associated with the underlined letters.</p> <p>For the menu options, select the Alt + underlined letter combination to access a main menu, and then select the underlined letter to access the individual menu item.</p> <p>For other interface components, use the Alt + underlined letter combination.</p>
Ctrl+F1	Display or conceal a tool tip when keyboard focus is on the toolbar.
Spacebar	Select an item or activate a hyperlink.
Ctrl+Spacebar (Contiguous/Non-contiguous) AMW Logical/Physical View	<p>Select multiple drives in the Physical View.</p> <p>To select multiple drives, select one drive by pressing Spacebar, and then press Tab to switch focus to the next drive you want to select; press Ctrl+Spacebar to select the drive.</p> <p>If you press Spacebar alone when multiple drives are selected then all selections are removed.</p> <p>Use the Ctrl+Spacebar combination to deselect a drive when multiple drives are selected.</p> <p>This behavior is the same for contiguous and non-contiguous selection of drives.</p>
End, Page Down	Move keyboard focus to the last item in the list.
Esc	Close the current dialog (does not require keyboard focus).
Home, Page Up	Move keyboard focus to the first item in the list.
Shift+Tab	Move keyboard focus through components in the reverse direction.
Ctrl+Tab	Move keyboard focus from a table to the next user interface component.
Tab	Navigate keyboard focus between components or select a hyperlink.
Down arrow	Move keyboard focus down one item in the list.
Left arrow	Move keyboard focus to the left.
Right arrow	Move keyboard focus to the right.
Up arrow	Move keyboard focus up one item in the list.

## Appendix I. Additional DS4000 documentation

The following tables present an overview of the IBM System Storage DS4000 Storage Manager, Storage Subsystem, and Storage Expansion Enclosure product libraries, as well as other related documents. Each table lists documents that are included in the libraries and what common tasks they address.

You can access the documents listed in these tables at both of the following Web sites:

[www.ibm.com/servers/storage/support/disk/](http://www.ibm.com/servers/storage/support/disk/)

[www.ibm.com/shop/publications/order/](http://www.ibm.com/shop/publications/order/)

### DS4000 Storage Manager Version 10 library

Table 29 associates each document in the DS4000 Version 10 Storage Manager library with its related common user tasks.

Table 29. DS4000 Storage Manager Version 10 titles by user tasks

Title	User tasks					
	Planning	Hardware installation	Software installation	Configuration	Operation and administration	Diagnosis and maintenance
<i>IBM System Storage DS4000 Storage Manager Installation and Host Support Guide for Windows 2000/Server 2003/2008, NetWare, VMWare ESX Server, and Linux</i>	✓		✓	✓		
<i>IBM System Storage DS4000 Storage Manager Installation and Host Support Guide for AIX, UNIX, Solaris, and Linux on POWER</i>	✓		✓	✓		
<i>IBM System Storage DS4000 Storage Manager Copy Services User's Guide</i>	✓		✓	✓	✓	
<i>IBM System Storage DS4000 Storage Manager Concepts Guide</i>	✓	✓	✓	✓	✓	✓

Table 29. DS4000 Storage Manager Version 10 titles by user tasks (continued)

Title	User tasks					
	Planning	Hardware installation	Software installation	Configuration	Operation and administration	Diagnosis and maintenance
<i>IBM System Storage DS4000 Fibre Channel and Serial ATA Intermix Premium Feature Installation Overview</i>	✓	✓	✓	✓		

## DS4800 Storage Subsystem library

Table 30 associates each document in the DS4800 Storage Subsystem library with its related common user tasks.

Table 30. DS4800 Storage Subsystem document titles by user tasks

Title	User Tasks					
	Planning	Hardware Installation	Software Installation	Configuration	Operation and Administration	Diagnosis and Maintenance
<i>IBM System Storage DS4800 Storage Subsystem Installation, User's and Maintenance Guide</i>	✓	✓		✓	✓	✓
<i>IBM System Storage Quick start guide, Quick reference for the DS4800</i>		✓	✓	✓		
<i>IBM TotalStorage DS4800 Controller Cache Upgrade Kit Instructions</i>	✓	✓		✓		



## DS4700 Storage Subsystem library

Table 31 associates each document in the DS4700 Storage Subsystem library with its related common user tasks.

Table 31. DS4700 Storage Subsystem document titles by user tasks

Title	User Tasks					
	Planning	Hardware Installation	Software Installation	Configuration	Operation and Administration	Diagnosis and Maintenance
<i>IBM System Storage DS4700 Storage Subsystem Installation, User's and Maintenance Guide</i>	✓	✓		✓	✓	✓
<i>IBM System Storage Quick start guide, Quick reference for the DS4700 and DS4200, Sections 2, 3, and 4 also for installing the EXP810 and EXP420</i>		✓	✓	✓		

## DS4500 Storage Subsystem library

Table 32 associates each document in the DS4500 (previously FASiT900) Storage Subsystem library with its related common user tasks.

Table 32. DS4500 Storage Subsystem document titles by user tasks

Title	User Tasks					
	Planning	Hardware Installation	Software Installation	Configuration	Operation and Administration	Diagnosis and Maintenance
<i>IBM TotalStorage DS4500 Storage Subsystem Installation, User's, and Maintenance Guide</i>	✓	✓		✓	✓	✓
<i>IBM TotalStorage DS4500 Storage Subsystem Cabling Instructions</i>	✓	✓				
<i>IBM TotalStorage DS4500 Rack Mounting Instructions</i>	✓	✓				

## DS4400 Storage Subsystem library

Table 33 associates each document in the DS4400 (previously FAStT700) Storage Subsystem library with its related common user tasks.

Table 33. DS4400 Storage Subsystem document titles by user tasks

Title	User Tasks					
	Planning	Hardware Installation	Software Installation	Configuration	Operation and Administration	Diagnosis and Maintenance
<i>IBM TotalStorage DS4400 Fibre Channel Storage Server User's Guide</i>	✓	✓		✓	✓	✓
<i>IBM TotalStorage DS4400 Fibre Channel Storage Server Installation and Support Guide</i>	✓	✓		✓	✓	
<i>IBM TotalStorage DS4400 Fibre Channel Cabling Instructions</i>	✓	✓				

## DS4300 Storage Subsystem library

Table 34 associates each document in the DS4300 (previously FASt600) Storage Subsystem library with its related common user tasks.

Table 34. DS4300 Storage Subsystem document titles by user tasks

Title	User Tasks					
	Planning	Hardware Installation	Software Installation	Configuration	Operation and Administration	Diagnosis and Maintenance
<i>IBM TotalStorage DS4300 Storage Subsystem Installation, User's, and Maintenance Guide</i>	✓	✓		✓	✓	✓
<i>IBM TotalStorage DS4300 Rack Mounting Instructions</i>	✓	✓				
<i>IBM TotalStorage DS4300 Storage Subsystem Cabling Instructions</i>	✓	✓				
<i>IBM TotalStorage DS4300 SCU Base Upgrade Kit</i>		✓	✓			
<i>IBM TotalStorage DS4300 SCU Turbo Upgrade Kit</i>		✓	✓			
<i>IBM TotalStorage DS4300 Turbo Models 6LU/6LX Upgrade Kit</i>		✓	✓			

## DS4200 Express Storage Subsystem library

Table 35 associates each document in the DS4200 Express Storage Subsystem library with its related common user tasks.

Table 35. DS4200 Express Storage Subsystem document titles by user tasks

Title	User Tasks					
	Planning	Hardware Installation	Software Installation	Configuration	Operation and Administration	Diagnosis and Maintenance
<i>IBM System Storage DS4200 Express Storage Subsystem Installation, User's and Maintenance Guide</i>	✓	✓		✓	✓	✓
<i>IBM System Storage Quick start guide, Quick reference for the DS4700 and DS4200, Sections 2, 3, and 4 also for installing the EXP810 and EXP420</i>		✓	✓	✓		

---

## DS4100 Storage Subsystem library

Table 36 associates each document in the DS4100 (previously FAStT100) Storage Subsystem library with its related common user tasks.

Table 36. DS4100 Storage Subsystem document titles by user tasks

Title	User Tasks					
	Planning	Hardware Installation	Software Installation	Configuration	Operation and Administration	Diagnosis and Maintenance
<i>IBM TotalStorage DS4100 Storage Server Installation, User's and Maintenance Guide</i>	✓	✓		✓	✓	✓
<i>IBM TotalStorage DS4100 Storage Server Cabling Guide</i>		✓				

## DS4000 Storage Expansion Enclosure documents

Table 37 associates each of the following documents with its related common user tasks.

Table 37. DS4000 Storage Expansion Enclosure document titles by user tasks

Title	User Tasks					
	Planning	Hardware Installation	Software Installation	Configuration	Operation and Administration	Diagnosis and Maintenance
<i>IBM System Storage DS4000 EXP810 Storage Expansion Enclosure Installation, User's, and Maintenance Guide</i>	✓	✓		✓	✓	✓
<i>IBM System Storage Quick start guide, Quick reference for the DS4700 and DS4200, Sections 2, 3, and 4 also for installing the EXP810 and EXP420</i>		✓	✓	✓		
<i>IBM TotalStorage DS4000 EXP700 and EXP710 Storage Expansion Enclosures Installation, User's, and Maintenance Guide</i>	✓	✓		✓	✓	✓
<i>IBM DS4000 EXP500 Installation and User's Guide</i>	✓	✓		✓	✓	✓
<i>IBM System Storage DS4000 EXP420 Storage Expansion Enclosure Installation, User's, and Maintenance Guide</i>	✓	✓		✓	✓	✓
<i>IBM System Storage DS4000 Hard Drive and Storage Expansion Enclosures Installation and Migration Guide</i>	✓	✓				

## Other DS4000 and DS4000-related documents

Table 38 associates each of the following documents with its related common user tasks.

Table 38. DS4000 and DS4000–related document titles by user tasks

Title	User Tasks					
	Planning	Hardware Installation	Software Installation	Configuration	Operation and Administration	Diagnosis and Maintenance
<i>IBM Safety Information</i>					✓	
<i>IBM TotalStorage DS4000 Hardware Maintenance Manual</i> <sup>1</sup>						✓
<i>IBM System Storage DS4000 Problem Determination Guide</i>						✓
<i>IBM Fibre Channel Planning and Integration: User's Guide and Service Information</i>	✓	✓			✓	✓
<i>IBM TotalStorage DS4000 FC2-133 Host Bus Adapter Installation and User's Guide</i>		✓			✓	
<i>IBM TotalStorage DS4000 FC2-133 Dual Port Host Bus Adapter Installation and User's Guide</i>		✓			✓	
<i>IBM Netfinity Fibre Channel Cabling Instructions</i>		✓				
<i>IBM Fibre Channel SAN Configuration Setup Guide</i>	✓		✓	✓	✓	

### Notes:

1. The *IBM TotalStorage DS4000 Hardware Maintenance Manual* does not contain maintenance information for the IBM System Storage DS4100, DS4200, DS4300, DS4500, DS4700, or DS4800 storage subsystems. You can find maintenance information for these products in the *IBM System Storage DSx000 Storage Subsystem Installation, User's, and Maintenance Guide* for the particular subsystem.



---

## Notices

This information was developed for products and services offered in the U.S.A.

IBM may not offer the products, services, or features discussed in this document in other countries. Consult your local IBM representative for information on the products and services currently available in your area. Any reference to an IBM product, program, or service is not intended to state or imply that only that IBM product, program, or service may be used. Any functionally equivalent product, program, or service that does not infringe any IBM intellectual property right may be used instead. However, it is the user's responsibility to evaluate and verify the operation of any non-IBM product, program, or service.

IBM may have patents or pending patent applications covering subject matter described in this document. The furnishing of this document does not grant you any license to these patents. You can send license inquiries, in writing, to:

*IBM Director of Licensing  
IBM Corporation  
North Castle Drive  
Armonk, NY 10504-1785  
U.S.A.*

For license inquiries regarding double-byte (DBCS) information, contact the IBM Intellectual Property Department in your country or send inquiries, in writing, to:

*IBM World Trade Asia Corporation  
Licensing  
2-31 Roppongi 3-chome, Minato-ku  
Tokyo 106-0032, Japan*

**The following paragraph does not apply to the United Kingdom or any other country where such provisions are inconsistent with local law:**

INTERNATIONAL BUSINESS MACHINES CORPORATION PROVIDES THIS PUBLICATIONS "AS IS" WITHOUT WARRANTY OF ANY KIND, EITHER EXPRESS OR IMPLIED, INCLUDING, BUT NOT LIMITED TO, THE IMPLIED WARRANTIES OF NON-INFRINGEMENT, MERCHANTABILITY OR FITNESS FOR A PARTICULAR PURPOSE. Some states do not allow disclaimer of express or implied warranties in certain transactions, therefore, this statement may not apply to you.

This information could include technical inaccuracies or typographical errors. Changes are periodically made to the information herein; these changes will be incorporated in new editions of the publications. IBM may make improvements or changes (or both) in the product(s) or program(s) (or both), described in this publication at any time without notice.

Any references in this information to non-IBM Web sites are provided for convenience only and do not in any manner serve as an endorsement of those Web sites. The materials at those Web sites are not part of the materials for this IBM product and use of those Web sites is at your own risk.

Information concerning non-IBM products was obtained from the suppliers of those products, their published announcements or other publicly available sources. IBM has not tested those products and cannot confirm the accuracy of performance,

compatibility or any other claims related to non-IBM products. Questions on the capabilities of non-IBM products should be addressed to the suppliers of those products.

IBM may use or distribute any of the information you supply in any way it believes appropriate without incurring any obligation to you.

Some software may differ from its retail version (if available), and may not include user manuals or all program functionality.

---

## Trademarks

The following terms are trademarks of International Business Machines Corporation in the United States, other countries, or both:

IBM  
AIX  
@server  
FlashCopy  
Netfinity  
POWER  
Series p  
RS/6000  
TotalStorage

Microsoft Windows and Windows NT<sup>®</sup> are registered trademarks of Microsoft Corporation in the United States, other countries, or both.

Java and all Java-based trademarks and logos are trademarks or registered trademarks of Sun Microsystems, Inc. in the United States, other countries, or both.

Linux is a registered trademark of Linus Torvalds in the United States, other countries, or both.

UNIX is a registered trademark of The Open Group in the United States and other countries.

Other company, product, or service names may be trademarks or service marks of others.

---

# Glossary

This glossary provides definitions for the terminology and abbreviations used in IBM System Storage DS4000 publications.

If you do not find the term you are looking for, see the *IBM Glossary of Computing Terms* located at the following Web site:

[www.ibm.com/ibm/terminology](http://www.ibm.com/ibm/terminology)

This glossary also includes terms and definitions from:

- *Information Technology Vocabulary* by Subcommittee 1, Joint Technical Committee 1, of the International Organization for Standardization and the International Electrotechnical Commission (ISO/IEC JTC1/SC1). Definitions are identified by the symbol (I) after the definition; definitions taken from draft international standards, committee drafts, and working papers by ISO/IEC JTC1/SC1 are identified by the symbol (T) after the definition, indicating that final agreement has not yet been reached among the participating National Bodies of SC1.
- *IBM Glossary of Computing Terms*. New York: McGraw-Hill, 1994.

The following cross-reference conventions are used in this glossary:

**See** Refers you to (a) a term that is the expanded form of an abbreviation or acronym, or (b) a synonym or more preferred term.

## See also

Refers you to a related term.

**Abstract Windowing Toolkit (AWT).** A Java graphical user interface (GUI).

**accelerated graphics port (AGP).** A bus specification that gives low-cost 3D graphics cards faster access to main memory on personal computers than the usual peripheral component interconnect (PCI) bus. AGP reduces the overall cost of creating high-end graphics subsystems by using existing system memory.

**access volume.** A special logical drive that allows the host-agent to communicate with the controllers in the storage subsystem.

**adapter.** A printed circuit assembly that transmits user data input/output (I/O) between the internal bus of the

host system and the external fibre-channel (FC) link and vice versa. Also called an I/O adapter, host adapter, or FC adapter.

**advanced technology (AT<sup>®</sup>) bus architecture.** A bus standard for IBM compatibles. It extends the XT™ bus architecture to 16 bits and also allows for bus mastering, although only the first 16 MB of main memory are available for direct access.

**agent.** A server program that receives virtual connections from the network manager (the client program) in a Simple Network Management Protocol-Transmission Control Protocol/Internet Protocol (SNMP-TCP/IP) network-managing environment.

**AGP.** See *accelerated graphics port*.

**AL\_PA.** See *arbitrated loop physical address*.

**arbitrated loop.** One of three existing fibre-channel topologies, in which 2 - 126 ports are interconnected serially in a single loop circuit. Access to the Fibre Channel Arbitrated Loop (FC-AL) is controlled by an arbitration scheme. The FC-AL topology supports all classes of service and guarantees in-order delivery of FC frames when the originator and responder are on the same FC-AL. The default topology for the disk array is arbitrated loop. An arbitrated loop is sometimes referred to as a Stealth Mode.

**arbitrated loop physical address (AL\_PA).** An 8-bit value that is used to uniquely identify an individual port within a loop. A loop can have one or more AL\_PAs.

**array.** A collection of fibre-channel or SATA hard drives that are logically grouped together. All the drives in the array are assigned the same RAID level. An array is sometimes referred to as a "RAID set." See also *redundant array of independent disks (RAID)*, *RAID level*.

**asynchronous write mode.** In remote mirroring, an option that allows the primary controller to return a write I/O request completion to the host server before data has been successfully written by the secondary controller. See also *synchronous write mode*, *remote mirroring*, *Global Copy*, *Global Mirroring*.

**AT.** See *advanced technology (AT) bus architecture*.

**ATA.** See *AT-attached*.

**AT-attached.** Peripheral devices that are compatible with the original IBM AT computer standard in which signals on a 40-pin AT-attached (ATA) ribbon cable followed the timings and constraints of the Industry Standard Architecture (ISA) system bus on the IBM PC AT computer. Equivalent to integrated drive electronics (IDE).

**auto-volume transfer/auto-disk transfer (AVT/ADT).**

A function that provides automatic failover in case of controller failure on a storage subsystem.

**AVT/ADT.** See *auto-volume transfer/auto-disk transfer*.

**AWT.** See *Abstract Windowing Toolkit*.

**basic input/output system (BIOS).** The personal computer code that controls basic hardware operations, such as interactions with diskette drives, hard disk drives, and the keyboard.

**BIOS.** See *basic input/output system*.

**BOOTP.** See *bootstrap protocol*.

**bootstrap protocol (BOOTP).** In Transmission Control Protocol/Internet Protocol (TCP/IP) networking, an alternative protocol by which a diskless machine can obtain its Internet Protocol (IP) address and such configuration information as IP addresses of various servers from a BOOTP server.

**bridge.** A storage area network (SAN) device that provides physical and transport conversion, such as fibre channel to small computer system interface (SCSI) bridge.

**bridge group.** A bridge and the collection of devices connected to it.

**broadcast.** The simultaneous transmission of data to more than one destination.

**cathode ray tube (CRT).** A display device in which controlled electron beams are used to display alphanumeric or graphical data on an electroluminescent screen.

**client.** A computer system or process that requests a service of another computer system or process that is typically referred to as a server. Multiple clients can share access to a common server.

**command.** A statement used to initiate an action or start a service. A command consists of the command name abbreviation, and its parameters and flags if applicable. A command can be issued by typing it on a command line or selecting it from a menu.

**community string.** The name of a community contained in each Simple Network Management Protocol (SNMP) message.

**concurrent download.** A method of downloading and installing firmware that does not require the user to stop I/O to the controllers during the process.

**CRC.** See *cyclic redundancy check*.

**CRT.** See *cathode ray tube*.

**CRU.** See *customer replaceable unit*.

**customer replaceable unit (CRU).** An assembly or part that a customer can replace in its entirety when any of its components fail. Contrast with *field replaceable unit (FRU)*.

**cyclic redundancy check (CRC).** (1) A redundancy check in which the check key is generated by a cyclic algorithm. (2) An error detection technique performed at both the sending and receiving stations.

**dac.** See *disk array controller*.

**dar.** See *disk array router*.

**DASD.** See *direct access storage device*.

**data striping.** See *striping*.

**default host group.** A logical collection of discovered host ports, defined host computers, and defined host groups in the storage-partition topology that fulfill the following requirements:

- Are not involved in specific logical drive-to-LUN mappings
- Share access to logical drives with default logical drive-to-LUN mappings

**device type.** Identifier used to place devices in the physical map, such as the switch, hub, or storage.

**DHCP.** See *Dynamic Host Configuration Protocol*.

**direct access storage device (DASD).** A device in which access time is effectively independent of the location of the data. Information is entered and retrieved without reference to previously accessed data. (For example, a disk drive is a DASD, in contrast with a tape drive, which stores data as a linear sequence.) DASDs include both fixed and removable storage devices.

**direct memory access (DMA).** The transfer of data between memory and an input/output (I/O) device without processor intervention.

**disk array controller (dac).** A disk array controller device that represents the two controllers of an array. See also *disk array router*.

**disk array router (dar).** A disk array router that represents an entire array, including current and deferred paths to all logical unit numbers (LUNs) (hdisks on AIX). See also *disk array controller*.

**DMA.** See *direct memory access*.

**domain.** The most significant byte in the node port (N\_port) identifier for the fibre-channel (FC) device. It is not used in the fibre channel-small computer system interface (FC-SCSI) hardware path ID. It is required to be the same for all SCSI targets logically connected to an FC adapter.

**drive channels.** The DS4200, DS4700, and DS4800 subsystems use dual-port drive channels that, from the physical point of view, are connected in the same way as two drive loops. However, from the point of view of the number of drives and enclosures, they are treated as a single drive loop instead of two different drive loops. A group of storage expansion enclosures are connected to the DS4000 storage subsystems using a drive channel from each controller. This pair of drive channels is referred to as a redundant drive channel pair.

**drive loops.** A drive loop consists of one channel from each controller combined to form one pair of redundant drive channels or a redundant drive loop. Each drive loop is associated with two ports. (There are two drive channels and four associated ports per controller.) For the DS4800, drive loops are more commonly referred to as drive channels. See *drive channels*.

**DRAM.** See *dynamic random access memory*.

**Dynamic Host Configuration Protocol (DHCP).** A protocol defined by the Internet Engineering Task Force that is used for dynamically assigning Internet Protocol (IP) addresses to computers in a network.

**dynamic random access memory (DRAM).** A storage in which the cells require repetitive application of control signals to retain stored data.

**ECC.** See *error correction coding*.

**EEPROM.** See *electrically erasable programmable read-only memory*.

**EISA.** See *Extended Industry Standard Architecture*.

**electrically erasable programmable read-only memory (EEPROM).** A type of memory chip which can retain its contents without consistent electrical power. Unlike the PROM which can be programmed only once, the EEPROM can be erased electrically. Because it can only be reprogrammed a limited number of times before it wears out, it is appropriate for storing small amounts of data that are changed infrequently.

**electrostatic discharge (ESD).** The flow of current that results when objects that have a static charge come into close enough proximity to discharge.

**environmental service module (ESM) canister.** A component in a storage expansion enclosure that monitors the environmental condition of the components in that enclosure. Not all storage subsystems have ESM canisters.

**E\_port.** See *expansion port*.

**error correction coding (ECC).** A method for encoding data so that transmission errors can be detected and corrected by examining the data on the

receiving end. Most ECCs are characterized by the maximum number of errors they can detect and correct.

**ESD.** See *electrostatic discharge*.

**ESM canister.** See *environmental service module canister*.

**automatic ESM firmware synchronization.** When you install a new ESM into an existing storage expansion enclosure in a DS4000 storage subsystem that supports automatic ESM firmware synchronization, the firmware in the new ESM is automatically synchronized with the firmware in the existing ESM.

**EXP.** See *storage expansion enclosure*.

**expansion port (E\_port).** A port that connects the switches for two fabrics.

**Extended Industry Standard Architecture (EISA).** A bus standard for IBM compatibles that extends the Industry Standard Architecture (ISA) bus architecture to 32 bits and allows more than one central processing unit (CPU) to share the bus. See also *Industry Standard Architecture*.

**fabric.** A fibre channel entity which interconnects and facilitates logins of N\_ports attached to it. The fabric is responsible for routing frames between source and destination N\_ports using address information in the frame header. A fabric can be as simple as a point-to-point channel between two N\_ports, or as complex as a frame-routing switch that provides multiple and redundant internal pathways within the fabric between F\_ports.

**fabric port (F\_port).** In a fabric, an access point for connecting a user's N\_port. An F\_port facilitates N\_port logins to the fabric from nodes connected to the fabric. An F\_port is addressable by the N\_port connected to it. See also *fabric*.

**FC.** See *Fibre Channel*.

**FC-AL.** See *arbitrated loop*.

**feature enable identifier.** A unique identifier for the storage subsystem, which is used in the process of generating a premium feature key. See also *premium feature key*.

**Fibre Channel (FC).** A set of standards for a serial input/output (I/O) bus capable of transferring data between two ports at up to 100 Mbps, with standards proposals to go to higher speeds. FC supports point-to-point, arbitrated loop, and switched topologies.

**Fibre Channel Arbitrated Loop (FC-AL).** See *arbitrated loop*.

**Fibre Channel Protocol (FCP) for small computer system interface (SCSI).** A high-level fibre-channel mapping layer (FC-4) that uses lower-level fibre-channel

(FC-PH) services to transmit SCSI commands, data, and status information between a SCSI initiator and a SCSI target across the FC link by using FC frame and sequence formats.

**field replaceable unit (FRU).** An assembly that is replaced in its entirety when any one of its components fails. In some cases, a field replaceable unit might contain other field replaceable units. Contrast with *customer replaceable unit (CRU)*.

**FlashCopy.** A premium feature for DS4000 that can make an instantaneous copy of the data in a volume.

**F\_port.** See *fabric port*.

**FRU.** See *field replaceable unit*.

**GBIC.** See *gigabit interface converter*

**gigabit interface converter (GBIC).** A transceiver that performs serial, optical-to-electrical, and electrical-to-optical signal conversions for high-speed networking. A GBIC can be hot swapped. See also *small form-factor pluggable*.

**Global Copy.** Refers to a remote logical drive mirror pair that is set up using asynchronous write mode without the write consistency group option. This is also referred to as "Asynchronous Mirroring without Consistency Group." Global Copy does not ensure that write requests to multiple primary logical drives are carried out in the same order on the secondary logical drives as they are on the primary logical drives. If it is critical that writes to the primary logical drives are carried out in the same order in the appropriate secondary logical drives, Global Mirroring should be used instead of Global Copy. See also *asynchronous write mode*, *Global Mirroring*, *remote mirroring*, *Metro Mirroring*.

**Global Mirroring.** Refers to a remote logical drive mirror pair that is set up using asynchronous write mode with the write consistency group option. This is also referred to as "Asynchronous Mirroring with Consistency Group." Global Mirroring ensures that write requests to multiple primary logical drives are carried out in the same order on the secondary logical drives as they are on the primary logical drives, preventing data on the secondary logical drives from becoming inconsistent with the data on the primary logical drives. See also *asynchronous write mode*, *Global Copy*, *remote mirroring*, *Metro Mirroring*.

**graphical user interface (GUI).** A type of computer interface that presents a visual metaphor of a real-world scene, often of a desktop, by combining high-resolution graphics, pointing devices, menu bars and other menus, overlapping windows, icons, and the object-action relationship.

**GUI.** See *graphical user interface*.

**HBA.** See *host bus adapter*.

**hdisk.** An AIX term representing a logical unit number (LUN) on an array.

**heterogeneous host environment.** A host system in which multiple host servers, which use different operating systems with their own unique disk storage subsystem settings, connect to the same DS4000 storage subsystem at the same time. See also *host*.

**host.** A system that is directly attached to the storage subsystem through a fibre-channel input/output (I/O) path. This system is used to serve data (typically in the form of files) from the storage subsystem. A system can be both a storage management station and a host simultaneously.

**host bus adapter (HBA).** An interface between the fibre-channel network and a workstation or server.

**host computer.** See *host*.

**host group.** An entity in the storage partition topology that defines a logical collection of host computers that require shared access to one or more logical drives.

**host port.** Ports that physically reside on the host adapters and are automatically discovered by the DS4000 Storage Manager software. To give a host computer access to a partition, its associated host ports must be defined.

**hot swap.** To replace a hardware component without turning off the system.

**hub.** In a network, a point at which circuits are either connected or switched. For example, in a star network, the hub is the central node; in a star/ring network, it is the location of wiring concentrators.

**IBMSAN driver.** The device driver that is used in a Novell NetWare environment to provide multipath input/output (I/O) support to the storage controller.

**IC.** See *integrated circuit*.

**IDE.** See *integrated drive electronics*.

**in-band.** Transmission of management protocol over the fibre-channel transport.

**Industry Standard Architecture (ISA).** Unofficial name for the bus architecture of the IBM PC/XT™ personal computer. This bus design included expansion slots for plugging in various adapter boards. Early versions had an 8-bit data path, later expanded to 16 bits. The "Extended Industry Standard Architecture" (EISA) further expanded the data path to 32 bits. See also *Extended Industry Standard Architecture*.

**initial program load (IPL).** The initialization procedure that causes an operating system to commence operation. Also referred to as a system restart, system startup, and boot.

**integrated circuit (IC).** A microelectronic semiconductor device that consists of many interconnected transistors and other components. ICs are constructed on a small rectangle cut from a silicon crystal or other semiconductor material. The small size of these circuits allows high speed, low power dissipation, and reduced manufacturing cost compared with board-level integration. Also known as a *chip*.

**integrated drive electronics (IDE).** A disk drive interface based on the 16-bit IBM personal computer Industry Standard Architecture (ISA) in which the controller electronics reside on the drive itself, eliminating the need for a separate adapter card. Also known as an Advanced Technology Attachment Interface (ATA).

**Internet Protocol (IP).** A protocol that routes data through a network or interconnected networks. IP acts as an intermediary between the higher protocol layers and the physical network.

**Internet Protocol (IP) address.** The unique 32-bit address that specifies the location of each device or workstation on the Internet. For example, 9.67.97.103 is an IP address.

**interrupt request (IRQ).** A type of input found on many processors that causes the processor to suspend normal processing temporarily and start running an interrupt handler routine. Some processors have several interrupt request inputs that allow different priority interrupts.

**IP.** See *Internet Protocol*.

**IPL.** See *initial program load*.

**IRQ.** See *interrupt request*.

**ISA.** See *Industry Standard Architecture*.

**Java Runtime Environment (JRE).** A subset of the Java Development Kit (JDK) for end users and developers who want to redistribute the Java Runtime Environment (JRE). The JRE consists of the Java virtual machine, the Java Core Classes, and supporting files.

**JRE.** See *Java Runtime Environment*.

**label.** A discovered or user entered property value that is displayed underneath each device in the Physical and Data Path maps.

**LAN.** See *local area network*.

**LBA.** See *logical block address*.

**local area network (LAN).** A computer network located on a user's premises within a limited geographic area.

**logical block address (LBA).** The address of a logical block. Logical block addresses are typically used in hosts' I/O commands. The SCSI disk command protocol, for example, uses logical block addresses.

**logical partition (LPAR).** (1) A subset of a single system that contains resources (processors, memory, and input/output devices). A logical partition operates as an independent system. If hardware requirements are met, multiple logical partitions can exist within a system. (2) A fixed-size portion of a logical volume. A logical partition is the same size as the physical partitions in its volume group. Unless the logical volume of which it is a part is mirrored, each logical partition corresponds to, and its contents are stored on, a single physical partition. (3) One to three physical partitions (copies). The number of logical partitions within a logical volume is variable.

**logical unit number (LUN).** An identifier used on a small computer system interface (SCSI) bus to distinguish among up to eight devices (logical units) with the same SCSI ID.

**loop address.** The unique ID of a node in fibre-channel loop topology sometimes referred to as a loop ID.

**loop group.** A collection of storage area network (SAN) devices that are interconnected serially in a single loop circuit.

**loop port.** A node port (N\_port) or fabric port (F\_port) that supports arbitrated loop functions associated with an arbitrated loop topology.

**LPAR.** See *logical partition*.

**LUN.** See *logical unit number*.

**MAC.** See *medium access control*.

**management information base (MIB).** The information that is on an agent. It is an abstraction of configuration and status information.

**man pages.** In UNIX-based operating systems, online documentation for operating system commands, subroutines, system calls, file formats, special files, stand-alone utilities, and miscellaneous facilities. Invoked by the **man** command.

**MCA.** See *micro channel architecture*.

**media scan.** A media scan is a background process that runs on all logical drives in the storage subsystem for which it has been enabled, providing error detection on the drive media. The media scan process scans all

logical drive data to verify that it can be accessed, and optionally scans the logical drive redundancy information.

**medium access control (MAC).** In local area networks (LANs), the sublayer of the data link control layer that supports medium-dependent functions and uses the services of the physical layer to provide services to the logical link control sublayer. The MAC sublayer includes the method of determining when a device has access to the transmission medium.

**Metro Mirroring.** This term is used to refer to a remote logical drive mirror pair which is set up with synchronous write mode. See also *remote mirroring*, *Global Mirroring*.

**MIB.** See *management information base*.

**micro channel architecture (MCA).** Hardware that is used for PS/2 Model 50 computers and above to provide better growth potential and performance characteristics when compared with the original personal computer design.

**Microsoft Cluster Server (MSCS).** MSCS, a feature of Windows NT Server (Enterprise Edition), supports the connection of two servers into a cluster for higher availability and easier manageability. MSCS can automatically detect and recover from server or application failures. It can also be used to balance server workload and provide for planned maintenance.

**mini hub.** An interface card or port device that receives short-wave fiber channel GBICs or SFPs. These devices enable redundant fibre channel connections from the host computers, either directly or through a fibre channel switch or managed hub, over optical fiber cables to the DS4000 Storage Server controllers. Each DS4000 controller is responsible for two mini hubs. Each mini hub has two ports. Four host ports (two on each controller) provide a cluster solution without use of a switch. Two host-side mini hubs are shipped as standard. See also *host port*, *gigabit interface converter (GBIC)*, *small form-factor pluggable (SFP)*.

**mirroring.** A fault-tolerance technique in which information on a hard disk is duplicated on additional hard disks. See also *remote mirroring*.

**model.** The model identification that is assigned to a device by its manufacturer.

**MSCS.** See *Microsoft Cluster Server*.

**network management station (NMS).** In the Simple Network Management Protocol (SNMP), a station that runs management application programs that monitor and control network elements.

**NMI.** See *non-maskable interrupt*.

**NMS.** See *network management station*.

**non-maskable interrupt (NMI).** A hardware interrupt that another service request cannot overrule (mask). An NMI bypasses and takes priority over interrupt requests generated by software, the keyboard, and other such devices and is issued to the microprocessor only in disastrous circumstances, such as severe memory errors or impending power failures.

**node.** A physical device that allows for the transmission of data within a network.

**node port (N\_port).** A fibre-channel defined hardware entity that performs data communications over the fibre-channel link. It is identifiable by a unique worldwide name. It can act as an originator or a responder.

**nonvolatile storage (NVS).** A storage device whose contents are not lost when power is cut off.

**N\_port.** See *node port*.

**NVS.** See *nonvolatile storage*.

**NVSRAM.** Nonvolatile storage random access memory. See *nonvolatile storage*.

**Object Data Manager (ODM).** An AIX proprietary storage mechanism for ASCII stanza files that are edited as part of configuring a drive into the kernel.

**ODM.** See *Object Data Manager*.

**out-of-band.** Transmission of management protocols outside of the fibre-channel network, typically over Ethernet.

**partitioning.** See *storage partition*.

**parity check.** (1) A test to determine whether the number of ones (or zeros) in an array of binary digits is odd or even. (2) A mathematical operation on the numerical representation of the information communicated between two pieces. For example, if parity is odd, any character represented by an even number has a bit added to it, making it odd, and an information receiver checks that each unit of information has an odd value.

**PCI local bus.** See *peripheral component interconnect local bus*.

**PDF.** See *portable document format*.

**performance events.** Events related to thresholds set on storage area network (SAN) performance.

**peripheral component interconnect local bus (PCI local bus).** A local bus for PCs, from Intel, that provides a high-speed data path between the CPU and up to 10 peripherals (video, disk, network, and so on). The PCI bus coexists in the PC with the Industry Standard Architecture (ISA) or Extended Industry



Standard Architecture (EISA) bus. ISA and EISA boards plug into an IA or EISA slot, while high-speed PCI controllers plug into a PCI slot. See also *Industry Standard Architecture, Extended Industry Standard Architecture*.

**polling delay.** The time in seconds between successive discovery processes during which discovery is inactive.

**port.** A part of the system unit or remote controller to which cables for external devices (such as display stations, terminals, printers, switches, or external storage units) are attached. The port is an access point for data entry or exit. A device can contain one or more ports.

**portable document format (PDF).** A standard specified by Adobe® Systems, Incorporated, for the electronic distribution of documents. PDF files are compact; can be distributed globally by e-mail, the Web, intranets, or CD-ROM; and can be viewed with the Acrobat Reader, which is software from Adobe Systems that can be downloaded at no cost from the Adobe Systems home page.

**premium feature key.** A file that the storage subsystem controller uses to enable an authorized premium feature. The file contains the feature enable identifier of the storage subsystem for which the premium feature is authorized, and data about the premium feature. See also *feature enable identifier*.

**private loop.** A freestanding arbitrated loop with no fabric attachment. See also *arbitrated loop*.

**program temporary fix (PTF).** A temporary solution or bypass of a problem diagnosed by IBM in a current unaltered release of the program.

**PTF.** See *program temporary fix*.

**RAID.** See *redundant array of independent disks (RAID)*.

**RAID level.** An array's RAID level is a number that refers to the method used to achieve redundancy and fault tolerance in the array. See also *array, redundant array of independent disks (RAID)*.

**RAID set.** See *array*.

**RAM.** See *random-access memory*.

**random-access memory (RAM).** A temporary storage location in which the central processing unit (CPU) stores and executes its processes. Contrast with *DASD*.

**RDAC.** See *redundant disk array controller*.

**read-only memory (ROM).** Memory in which stored data cannot be changed by the user except under special conditions.

**recoverable virtual shared disk (RVSD).** A virtual shared disk on a server node configured to provide continuous access to data and file systems in a cluster.

**redundant array of independent disks (RAID).** A collection of disk drives (*array*) that appears as a single volume to the server, which is fault tolerant through an assigned method of data striping, mirroring, or parity checking. Each array is assigned a RAID level, which is a specific number that refers to the method used to achieve redundancy and fault tolerance. See also *array, parity check, mirroring, RAID level, striping*.

**redundant disk array controller (RDAC).** (1) In hardware, a redundant set of controllers (either active/passive or active/active). (2) In software, a layer that manages the input/output (I/O) through the active controller during normal operation and transparently reroutes I/Os to the other controller in the redundant set if a controller or I/O path fails.

**remote mirroring.** Online, real-time replication of data between storage subsystems that are maintained on separate media. The Enhanced Remote Mirror Option is a DS4000 premium feature that provides support for remote mirroring. See also *Global Mirroring, Metro Mirroring*.

**ROM.** See *read-only memory*.

**router.** A computer that determines the path of network traffic flow. The path selection is made from several paths based on information obtained from specific protocols, algorithms that attempt to identify the shortest or best path, and other criteria such as metrics or protocol-specific destination addresses.

**RVSD.** See *recoverable virtual shared disk*.

**SAI.** See *Storage Array Identifier*.

**SA Identifier.** See *Storage Array Identifier*.

**SAN.** See *storage area network*.

**SATA.** See *serial ATA*.

**scope.** Defines a group of controllers by their Internet Protocol (IP) addresses. A scope must be created and defined so that dynamic IP addresses can be assigned to controllers on the network.

**SCSI.** See *small computer system interface*.

**segmented loop port (SL\_port).** A port that allows division of a fibre-channel private loop into multiple segments. Each segment can pass frames around as an independent loop and can connect through the fabric to other segments of the same loop.

**sense data.** (1) Data sent with a negative response, indicating the reason for the response. (2) Data describing an I/O error. Sense data is presented to a host system in response to a sense request command.

**serial ATA.** The standard for a high-speed alternative to small computer system interface (SCSI) hard drives. The SATA-1 standard is equivalent in performance to a 10 000 RPM SCSI drive.

**serial storage architecture (SSA).** An interface specification from IBM in which devices are arranged in a ring topology. SSA, which is compatible with small computer system interface (SCSI) devices, allows full-duplex packet multiplexed serial data transfers at rates of 20 Mbps in each direction.

**server.** A functional hardware and software unit that delivers shared resources to workstation client units on a computer network.

**server/device events.** Events that occur on the server or a designated device that meet criteria that the user sets.

**SFP.** See *small form-factor pluggable*.

**Simple Network Management Protocol (SNMP).** In the Internet suite of protocols, a network management protocol that is used to monitor routers and attached networks. SNMP is an application layer protocol. Information on devices managed is defined and stored in the application's Management Information Base (MIB).

**SL\_port.** See *segmented loop port*.

**SMagent.** The DS4000 Storage Manager optional Java-based host-agent software, which can be used on Microsoft Windows, Novell NetWare, AIX, HP-UX, Solaris, and Linux on POWER host systems to manage storage subsystems through the host fibre-channel connection.

**SMclient.** The DS4000 Storage Manager client software, which is a Java-based graphical user interface (GUI) that is used to configure, manage, and troubleshoot storage servers and storage expansion enclosures in a DS4000 storage subsystem. SMclient can be used on a host system or on a storage management station.

**SMruntime.** A Java compiler for the SMclient.

**SMutil.** The DS4000 Storage Manager utility software that is used on Microsoft Windows, AIX, HP-UX, Solaris, and Linux on POWER host systems to register and map new logical drives to the operating system. In Microsoft Windows, it also contains a utility to flush the cached data of the operating system for a particular drive before creating a FlashCopy.

**small computer system interface (SCSI).** A standard hardware interface that enables a variety of peripheral devices to communicate with one another.

**small form-factor pluggable (SFP).** An optical transceiver that is used to convert signals between

optical fiber cables and switches. An SFP is smaller than a gigabit interface converter (GBIC). See also *gigabit interface converter*.

**SNMP.** See *Simple Network Management Protocol and SNMPv1*.

**SNMP trap event.** (1) (2) An event notification sent by the SNMP agent that identifies conditions, such as thresholds, that exceed a predetermined value. See also *Simple Network Management Protocol*.

**SNMPv1.** The original standard for SNMP is now referred to as SNMPv1, as opposed to SNMPv2, a revision of SNMP. See also *Simple Network Management Protocol*.

**SRAM.** See *static random access memory*.

**SSA.** See *serial storage architecture*.

**static random access memory (SRAM).** Random access memory based on the logic circuit known as flip-flop. It is called static because it retains a value as long as power is supplied, unlike dynamic random access memory (DRAM), which must be regularly refreshed. It is however, still volatile, meaning that it can lose its contents when the power is turned off.

**storage area network (SAN).** A dedicated storage network tailored to a specific environment, combining servers, storage products, networking products, software, and services. See also *fabric*.

**Storage Array Identifier (SAI or SA Identifier).** The Storage Array Identifier is the identification value used by the DS4000 Storage Manager host software (SMClient) to uniquely identify each managed storage server. The DS4000 Storage Manager SMClient program maintains Storage Array Identifier records of previously-discovered storage servers in the host resident file, which allows it to retain discovery information in a persistent fashion.

**storage expansion enclosure (EXP).** A feature that can be connected to a system unit to provide additional storage and processing capacity.

**storage management station.** A system that is used to manage the storage subsystem. A storage management station does not need to be attached to the storage subsystem through the fibre-channel input/output (I/O) path.

**storage partition.** Storage subsystem logical drives that are visible to a host computer or are shared among host computers that are part of a host group.

**storage partition topology.** In the DS4000 Storage Manager client, the Topology view of the Mappings window displays the default host group, the defined host group, the host computer, and host-port nodes. The host port, host computer, and host group topological

elements must be defined to grant access to host computers and host groups using logical drive-to-LUN mappings.

**striping.** Splitting data to be written into equal blocks and writing blocks simultaneously to separate disk drives. Striping maximizes performance to the disks. Reading the data back is also scheduled in parallel, with a block being read concurrently from each disk then reassembled at the host.

**subnet.** An interconnected but independent segment of a network that is identified by its Internet Protocol (IP) address.

**sweep method.** A method of sending Simple Network Management Protocol (SNMP) requests for information to all the devices on a subnet by sending the request to every device in the network.

**switch.** A fibre-channel device that provides full bandwidth per port and high-speed routing of data by using link-level addressing.

**switch group.** A switch and the collection of devices connected to it that are not in other groups.

**switch zoning.** See *zoning*.

**synchronous write mode.** In remote mirroring, an option that requires the primary controller to wait for the acknowledgment of a write operation from the secondary controller before returning a write I/O request completion to the host. See also *asynchronous write mode*, *remote mirroring*, *Metro Mirroring*.

**system name.** Device name assigned by the vendor's third-party software.

**TCP.** See *Transmission Control Protocol*.

**TCP/IP.** See *Transmission Control Protocol/Internet Protocol*.

**terminate and stay resident program (TSR program).** A program that installs part of itself as an extension of DOS when it is executed.

**topology.** The physical or logical arrangement of devices on a network. The three fibre-channel topologies are fabric, arbitrated loop, and point-to-point. The default topology for the disk array is arbitrated loop.

**TL\_port.** See *translated loop port*.

**transceiver.** A device that is used to transmit and receive data. Transceiver is an abbreviation of transmitter-receiver.

**translated loop port (TL\_port).** A port that connects to a private loop and allows connectivity between the private loop devices and off loop devices (devices not connected to that particular TL\_port).

**Transmission Control Protocol (TCP).** A communication protocol used in the Internet and in any network that follows the Internet Engineering Task Force (IETF) standards for internetwork protocol. TCP provides a reliable host-to-host protocol between hosts in packed-switched communication networks and in interconnected systems of such networks. It uses the Internet Protocol (IP) as the underlying protocol.

**Transmission Control Protocol/Internet Protocol (TCP/IP).** A set of communication protocols that provide peer-to-peer connectivity functions for both local and wide-area networks.

**trap.** In the Simple Network Management Protocol (SNMP), a message sent by a managed node (agent function) to a management station to report an exception condition.

**trap recipient.** Receiver of a forwarded Simple Network Management Protocol (SNMP) trap. Specifically, a trap receiver is defined by an Internet Protocol (IP) address and port to which traps are sent. Presumably, the actual recipient is a software application running at the IP address and listening to the port.

**TSR program.** See *terminate and stay resident program*.

**uninterruptible power supply.** A source of power from a battery that is installed between a computer system and its power source. The uninterruptible power supply keeps the system running if a commercial power failure occurs, until an orderly shutdown of the system can be performed.

**user action events.** Actions that the user takes, such as changes in the storage area network (SAN), changed settings, and so on.

**worldwide port name (WWPN).** A unique identifier for a switch on local and global networks.

**worldwide name (WWN).** A globally unique 64-bit identifier assigned to each fibre channel port.

**WORM.** See *write-once read-many*.

**write-once read many (WORM).** Any type of storage medium to which data can be written only a single time, but can be read from any number of times. After the data is recorded, it cannot be altered.

**WWN.** See *worldwide name*.

**zoning.** (1) In fibre channel environments, the grouping of multiple ports to form a virtual, private, storage network. Ports that are members of a zone can communicate with each other, but are isolated from ports in other zones. (2) A function that allows segmentation of nodes by address, name, or physical port and is provided by fabric switches or hubs.



---

# Index

## Special characters

(BladeCenter) 158

### A

about this document xiii  
access volume/logical drive 6, 10, 29, 63, 90, 115, 155  
additional storage  
    See storage expansion enclosures  
address  
    of the IBM director of licensing 263  
address, IBM xxii  
agent software  
    AIX 33  
    HP-UX 88  
    package info 5  
    Red Hat Linux 167  
    Solaris 113  
AIX  
    boot restrictions 28  
    client software 31  
    concurrent firmware download 36  
    configuration of storage subsystems 35  
    direct-attached configuration 44  
    dynamic capacity expansion (DCE) 70  
    dynamic volume expansion (DVE) 70  
    fast I/O failure 69  
    FCP disk array errors 79  
    fget\_config command 53  
    firmware  
        requirements 20  
        upgrading 39  
    hardware requirements 20, 27  
    identifying  
        controller ID numbers 50  
        device names and bus numbers 51  
        FlashCopy logical drive types 59  
        logical drives by operating system device names 57  
    logical drives, redistributing in case of failure 81  
    lsattr command 56  
    lsdev command 52  
    NVS RAM  
        requirements 27  
        upgrading 40  
    operating system requirements 27  
    RDAC driver  
        configuring 47  
        installing 45, 46, 47  
        requirements 46  
    requirements  
        client software 31  
        firmware 20  
        hardware 20, 27  
        operating system 27  
        RDAC driver 46  
        software 27

AIX (*continued*)  
    requirements (*continued*)  
        system 27  
    restrictions 28  
    SAN-attached configuration 45  
    SMagent 33  
    SMclient 32  
    SMesm 32  
    SMruntime 32  
    SMutil 33  
    software requirements 27  
    staged controller firmware download 37  
    system requirements 27  
    verifying configuration 50  
AIX RDAC  
    file sets 47  
alert notifications, configuring 205  
appware  
    AIX firmware 20  
    HP-UX firmware 20  
    Red Hat Linux firmware 20  
    Solaris firmware 20  
    SUSE Linux firmware 20  
arrays, creating 202  
attributes  
    dac 67  
    dar 67  
    hdisk 65, 67, 68  
    LUN 65, 67, 68  
    RDAC driver 47  
audience of this document xiii  
Auto Volume Transfer (AVT) 105, 149  
automatic ESM firmware synchronization  
    defined 232  
    Event Monitor requirement 232

### B

BladeCenter 158  
boot, AIX restrictions 28  
BOOTP server  
    sample network 12, 13  
bus numbers and device names, identifying 51

### C

cache mirroring 68, 80, 213  
capture state information feature 206  
catastrophic failure 206  
check drive firmware level 234  
client software  
    AIX 31, 32  
    HP-UX 86, 87  
    package info 4, 5  
    Red Hat Linux 164, 165, 166  
    Solaris 109, 110, 112

- cluster services
  - AIX requirements 211, 213
  - configurations 201
  - HACMP ES and ESCRM 211
  - hardware requirements 210
  - HP-UX requirements 209
  - MC/Service Guard 209, 221
  - PSSP with GPFS 213
  - Solaris requirements 210, 211
  - system dependencies 209
  - VERITAS Cluster Server 210
  - VERITAS VolumeManager 210
- comments about this document, how to send xxii
- Concepts Guide 253
- concurrent download
  - controller firmware 36, 91, 116, 169
  - ESM firmware 231
- configuration
  - details, MC Service Guard 221
  - file
    - modifying, Solaris (JNI HBAs) 125
  - recovery 206
- configuration recovery 202
- configuring
  - alert notifications 205
  - direct-attached 44, 99, 123, 155
  - RDAC driver 47, 211
  - SAN-attached 45, 99, 123, 155
  - Solaris with Emulex host bus adapter cards 123
  - Solaris with JNI host bus adapter cards 125
  - Solaris with QLogic host bus adapter cards 123
  - storage subsystems
    - AIX 35, 44, 45
    - HP-UX 90, 99
    - initial automatic discovery 201
    - Red Hat Linux 155
    - Solaris 115, 123
    - SUSE Linux 155
- controller state capture 206
- controllers
  - firmware 2, 90, 115
  - ID numbers, identifying 50
  - IP addresses 13
- Copy Services Guide 253
- creating
  - arrays and logical drives 202

**D**

- dac (disk array controller)
  - and fget\_config command 53
  - and lsattr command 56
  - and RDAC 47
  - attributes 67
  - identifying controller ID numbers 50
  - showing status and location 52
- daisy-chain configuration 44
- dar (disk array router)
  - and fget\_config command 53
  - and lsattr command 56
  - and RDAC 47
- dar (disk array router) *(continued)*
  - attributes 67
  - showing status 52
  - two dars on one subsystem, causes 49
- DCE (dynamic capacity expansion) 70, 182
- default host type, changing
  - AIX 42
  - HP-UX 97
  - Red Hat Linux 173
  - Solaris 121
- device drivers
  - DMP
    - configuring VERITAS VolumeManager for 147
  - DMP, installing 144
  - downloading latest versions 1
  - RDAC
    - AIX, file sets 46
    - description 30, 134, 175
    - installing 45, 142
    - viewing attributes 47
    - with HACMP cluster 213
- devices
  - identification 48
  - names and bus numbers, identifying 51
- DHCP server
  - sample network 12, 13
- Diagnostic Data Capture
  - Recovery Guru 247
  - Script Editor 247
- direct management method
  - See out-of-band (direct) management method
- direct-attached configuration 44, 99, 123, 155
- disk array controller
  - See dac
- disk array router
  - See dar
- disk configuration information 206
- DMP
  - See Dynamic Multipathing (DMP)
- documentation
  - documents 2
  - DS4000 253
  - DS4000 Storage Manager 253
  - DS4000-related documents 262
  - DS4100 SATA Storage Subsystem 260
  - DS4200 Express Storage Subsystem 259
  - DS4300 Fibre Channel Storage Subsystem 258
  - DS4400 Fibre Channel Storage Subsystem 257
  - DS4500 Storage Subsystem 256
  - DS4700 Storage Subsystem 255
  - DS4800 Storage Subsystem 254
  - files 1
  - online help 6, 202, 207
  - Sun Solaris 135
  - Web sites xx
- drive firmware download 232
- drive firmware, level 234
- drivers
  - See device drivers
- DS4000
  - Hardware Maintenance Manual 262

- DS4000 (*continued*)
  - Problem Determination Guide 262
  - Storage Expansion Enclosure documentation 261
- DS4000 documentation 253
- DS4000 Storage Manager
  - documentation 253
  - related documents 262
- DS4100
  - Storage Subsystem library 260
- DS4200 Express
  - Storage Subsystem library 259
- DS4300
  - restrictions 8
  - Storage Subsystem library 258
  - usage notes 8
- DS4400
  - Storage Subsystem library 257
- DS4500
  - Storage Subsystem library 256
- DS4700
  - Storage Subsystem library 255
- DS4800
  - Storage Subsystem library 254
- DVE (dynamic volume expansion) 70, 182
- dynamic capacity expansion (DCE) 70, 182
- Dynamic Multipathing (DMP)
  - configuring VERITAS VolumeManager for 147
  - description 134
  - disabling 210
  - installing 144
  - installing the SMibmasl package 147
  - installing VERITAS VolumeManager packages 147
  - preparing for installation 145
  - system requirements 144
- dynamic tracking 70
- dynamic volume expansion (DVE) 70, 182

## E

- e-mail address 206
- edition notice ii
- Emulex
  - cards 123
- enabling
  - multipath I/O with PV-links 100
- enhancements 7
- Enterprise Management window
  - description 5
  - online help 7
- errors, FCP disk array 79
- ESM firmware
  - automatic ESM firmware synchronization 232
  - download 229
- esm software
  - AIX 32
  - HP-UX 87
  - Red Hat Linux 166
  - Solaris 110
- Ethernet
  - and out-of-band (direct) management 10
  - managing subsystems through 10

- Ethernet (*continued*)
  - setting up subsystems with 35, 90, 168
  - Solaris requirements 107, 210

## F

- fabric switch environment 245
- failure support
  - cluster services 209
  - DMP driver 134, 175
  - MPxIO 134
  - RDAC driver 30, 134, 175
  - redistributing logical drives 81, 105, 149
- fast I/O failure 69
- FC switch zoning 245
- FCP disk array errors 79
- fcsci attributes 69, 70
- features
  - disabling 19
- features, new 7
- features, premium
  - enabling 18
  - feature enable identifier 18
  - feature key file 18
- fget\_config command 53
- fire suppression xxii
- firmware
  - AIX
    - concurrent firmware download 36
    - downloading latest versions 36
    - requirements 20
    - staged controller firmware download 37
    - upgrading 39
  - description 2
  - drive 232
  - ESM 229
  - HP-UX
    - concurrent firmware download 91
    - downloading latest versions 91
    - requirements 20
    - staged controller firmware download 91
    - upgrading 94
  - Red Hat Linux
    - concurrent firmware download 169
    - downloading latest versions 169
    - requirements 20
    - staged controller firmware download 169
    - upgrading 171
  - restrictions 5, 8, 9, 15, 37, 88, 92, 113, 116, 167, 169, 229
  - Solaris
    - concurrent firmware download 116
    - downloading latest versions 115
    - requirements 20
    - staged controller firmware download 116
    - upgrading 118
  - SUSE Linux
    - concurrent firmware download 169
    - downloading latest versions 169
    - requirements 20
    - staged controller firmware download 169

firmware (*continued*)  
  SUSE Linux (*continued*)  
    upgrading 171  
FlashCopy  
  disk array error messages (AIX) 80  
  identifying logical drive types 59  
form, reader comment xxii

## G

General Parallel File System (GPFS) 213  
glossary 265

## H

HACMP  
  See High Availability Cluster Multi-Processing (HACMP)  
hardware requirements  
  AIX 20, 27  
  HP-UX 20, 83  
  Red Hat Linux 20, 153  
  Solaris 20, 107  
  SUSE Linux 20, 151  
hardware service and support xxii  
HBA in switch environment 245  
hdisk  
  and fget\_config command 53  
  and lsattr command 56  
  and RDAC 47  
  attributes 65, 67, 68  
  determining preferred path 53  
  setting queue depth 65  
  showing status and location 52  
  verification 48  
heterogeneous environment 197  
High Availability Cluster Multi-Processing (HACMP) 211  
high-availability cluster services 209  
host bus adapters  
  AIX  
    defining host groups 41  
    displaying a list 42  
    in a direct-attached configuration 44  
    in a SAN-attached configuration 45  
    setting host ports 40  
    single HBA configuration 44  
  HP-UX  
    defining host groups 95  
    displaying a list 95  
    in a direct-attached configuration 99  
    in a SAN-attached configuration 99  
    setting host ports 95  
  Red Hat Linux  
    defining host groups 173  
    displaying a list 159, 162  
    in a direct-attached configuration 155  
    in a SAN-attached configuration 155  
    setting host ports 172  
    single HBA configuration 155

host bus adapters (*continued*)  
  Solaris  
    defining host groups 120  
    in a direct-attached configuration 123  
    in a SAN-attached configuration 123  
    JNI settings 124, 125, 223  
    QLLogic settings 134, 228  
    setting host ports 119  
  SUSE Linux  
    downloading driver package 156, 160  
    in a direct-attached configuration 155  
    setting host ports 172  
    single HBA configuration 155  
host group, defining  
  AIX 40  
  HP-UX 95  
  Red Hat Linux 172  
  Solaris 119  
  SUSE Linux 172  
host software  
  AIX 33  
  HP-UX 88, 89  
  package info 5  
  Red Hat Linux 167  
  Solaris 113  
host type, changing default  
  AIX 42  
  HP-UX 97  
  Red Hat Linux 173  
  Solaris 121  
host-agent management method  
  See in-band (host-agent) management method  
how to send your comments xxii  
HP-UX  
  client software 86  
  cluster services, requirements 209  
  concurrent firmware download 91  
  configuration of storage subsystems 90  
  direct-attached configuration 99  
  firmware  
    requirements 20  
    upgrading 94  
  hardware requirements 20, 83  
  host software  
    installing 88  
    requirements 88  
  logical drives, redistributing in case of failure 105  
  NVSRAM  
    requirements 20  
    upgrading 94  
  PV-links 100  
  requirements  
    client software 86  
    cluster services 209  
    firmware 20  
    hardware 20, 83  
    host software 88  
    NVSRAM 20  
    software 83  
    system 83  
  SAN-attached configuration 99



HP-UX (*continued*)  
SMagent 88  
SMclient 87  
SMesm 87  
SMruntime 86  
SMutil 89  
software requirements 83  
staged controller firmware download 91  
system requirements 83

## I

IBM  
director of licensing address 263  
e-mail address 206  
IBM address xxii  
IBM Safety Information 262  
in-band (host-agent) management method  
advantages 9  
description 9  
diagram 12  
disadvantages 10  
utm device 48  
with SMagent software 5, 33, 88, 113  
installing  
AIX  
client software 31, 32  
esm software 32  
RDAC driver 45, 46  
util software 33  
client software  
AIX 31  
HP-UX 86  
Red Hat Linux 165  
SMclient 32, 87, 112, 166  
SMruntime 32, 86, 110, 165  
Solaris 110  
esm software  
SMesm 32, 87, 110, 166  
host software  
HP-UX 88  
SMagent 33, 88, 113, 167  
SMutil 89, 114, 167  
Solaris 113  
HP-UX  
client software 86, 87  
esm software 87  
host software 88  
Red Hat Linux  
client software 165, 166  
esm software 166  
sequence of 5  
Solaris  
client software 110, 112  
esm software 110  
host software 113, 114  
RDAC driver 142  
util software  
SMutil 33  
interoperability  
AIX restrictions 29

Introduction  
AIX xiii  
HP-UX xiii  
Red Hat Linux xiii  
Solaris xiii  
SUSE Linux xiii  
IP addresses for DS4000 controllers 13

## J

JNI  
cards 125  
installing driver 124  
modifying HBA settings 125, 128  
settings 223

## L

Linux (Red Hat)  
client software 164, 165  
concurrent firmware download 169  
direct-attached configuration 155  
firmware  
requirements 20  
upgrading 171  
hardware requirements 20  
NVSRAM  
requirements 20  
upgrading 172  
requirements  
client software 164  
firmware 20  
hardware 20, 153  
operating system 151  
software 153  
system 153  
restrictions 153  
SAN-attached configuration 155  
SMagent 167  
SMclient 166  
SMesm 166  
SMruntime 165  
SMutil 167  
Linux (SUSE)  
concurrent firmware download 169  
direct-attached configuration 155  
dynamic capacity expansion (DCE) 182  
dynamic volume expansion (DVE) 182  
firmware  
requirements 20  
upgrading 171  
hardware requirements 20  
NVSRAM  
requirements 20  
upgrading 172  
requirements  
firmware 20  
hardware 20, 151  
operating system 151  
software 151  
system 151

- Linux (SUSE) *(continued)*
  - restrictions 153
  - staged controller firmware download 169
  - with BladeCenter 158
- load balancing 61
- load\_balancing attribute 61
- logical drives
  - configuration 205
  - creating 202
  - creating from free or unconfigured capacity 203
  - expected usage 205
  - redistributing in case of failure 81, 105, 149
- loop settings 125, 129
- lsattr command 56
- lsdev command 52
- LUNs
  - and access volumes 10
  - and fget\_config command 53
  - attributes 65, 67, 68
  - mapping to a partition
    - AIX 43
    - HP-UX 97
    - Red Hat Linux 174
    - Solaris 121
    - SUSE Linux 174
  - maximum number per partition 14

## M

- management method
  - in-band (host-agent) 9
  - out-of-band (direct) 10
- management station 6
  - description 3
- mapping
  - host group
    - AIX 41
    - HP-UX 95
    - Red Hat Linux 173
    - Solaris 120
  - LUNs, to a partition
    - AIX 43
    - HP-UX 97
    - Red Hat Linux 174
    - Solaris 121
    - SUSE Linux 174
  - SMutil 5
- MC/Service Guard 209, 221
- Migration Guide 253
- minihubs 28, 44, 99, 123, 154, 155
- MPxIO 134, 135
- multipath
  - and AIX fast I/O failure 69
  - DMP, installing on Solaris 144
  - MPxIO , using with Solaris 135
  - PV-links, using on HP-UX 100
  - RDAC
    - AIX devices 47
    - installing on AIX 45
    - installing on Solaris 142

- multipath *(continued)*
  - redistributing logical drives
    - AIX 81
    - HP-UX 105
    - Solaris 149
- Multiplexed I/O (MPxIO) 135
- My Support 3

## N

- new features 7
- new features in this edition 7
- notice, edition ii
- notices
  - general 263
- NVSRAM
  - AIX
    - concurrent download 36
    - requirements 27
    - upgrading 40
  - downloading latest versions 36, 91, 115, 169
  - HP-UX
    - concurrent download 91
    - requirements 20
    - upgrading 94
  - Red Hat Linux
    - concurrent download 169
    - requirements 20
    - upgrading 172
  - Solaris
    - concurrent download 116
    - requirements 20
    - upgrading 119
  - SUSE Linux
    - concurrent download 169
    - requirements 20
    - upgrading 172
- Object Data Manager (ODM) attributes
  - definitions 60
  - initial device identification 50
  - lsattr command 67
  - switch\_retries and concurrent download 36
  - viewing and setting 60
- online help 6, 202, 207
- operating system
  - AIX
    - requirements 27
  - HP-UX
    - installation and configuration requirements 83
    - requirements 83
  - Red Hat Linux
    - requirements 151, 153
  - Solaris
    - requirements 107
  - SUSE Linux
    - requirements 151
- out-of-band (direct) management method
  - advantages 11

- out-of-band (direct) management method *(continued)*
  - description 10
  - diagram 12
  - disadvantages 11
  - setting IP addresses 13
- overview of heterogeneous hosts 197

## P

- Parallel System Support Programs (PSSP) 213
- partitioning
  - See Storage Partitioning
- performance
  - in-band (host-agent) management disadvantage 10
  - ODM attribute settings and 65
  - out-of-band (direct) management advantage 11
  - planning 14
- premium features
  - disabling 19
  - enabling 18
  - feature enable identifier 18
  - feature key file 18
  - Storage Partitioning
    - host group 40, 95, 119, 172
- premium features, verifying if enabled 19
- prerequisites
  - AIX
    - client software 31
    - firmware 20
    - hardware 20, 27
    - RDAC driver 46
    - software 27
    - system 27
  - cluster services 210
  - HP-UX
    - client software 86
    - cluster services 209
    - firmware 20
    - hardware 20, 83
    - host software 88
    - NVSRAM 20
    - software 83
    - system 83
  - Red Hat Linux
    - client software 164
    - firmware 20
    - hardware 20, 153
    - software 153
    - system 153
  - Solaris
    - client software 109
    - cluster services 210, 211
    - firmware 20
    - hardware 20, 107
    - host software 113
    - NVSRAM 20
    - RDAC driver 113
    - software 107
    - system 107
  - SUSE Linux
    - firmware 20

- prerequisites *(continued)*
  - SUSE Linux *(continued)*
    - hardware 20, 151
    - software 151
    - system 151
- products, developed 263
- profile, storage subsystem
  - saving 37, 92, 117, 170, 206
  - viewing 37, 92, 117, 170
- PV-links 100

## Q

- QLogic
  - cards 123
  - installing adapter driver 132
  - settings 228
- queue depth, setting
  - AIX 65
  - Linux on POWER 184

## R

- RDAC driver
  - AIX
    - attributes 47
    - configuring 47
    - installing 46, 47
    - requirements 46
  - description 30, 134, 175
  - IDs 211
  - Solaris
    - installing 142
    - requirements 113
- reader comment form processing xxii
- readme files
  - finding online xx
- readme files, finding online 1
- recover configuration 202, 206
- Recovery Guru
  - Diagnostic Data Capture 247
- Red Hat Linux
  - See Linux (Red Hat)
- redistributing logical drives in case of failure
  - AIX 81
  - HP-UX 105
  - Solaris 149
- renaming storage subsystem 206
- requirements
  - AIX
    - client software 31
    - firmware 20
    - hardware 20, 27
    - RDAC driver 46
    - software 27
    - system 27
  - cluster services 210
  - HP-UX
    - client software 86
    - cluster services 209
    - firmware 20

requirements (*continued*)

- hardware 20, 83
- host software 88
- NVSRAM 20
- software 83
- system 83

Red Hat Linux

- client software 164
- firmware 20
- hardware 20, 153
- software 153
- system 153

Solaris

- client software 109
- cluster services 210, 211
- firmware 20
- hardware 20, 107
- host software 113
- NVSRAM 20
- RDAC driver 113
- software 107
- system 107

SUSE Linux

- firmware 20
- hardware 20, 151
- software 151
- system 151

resources

- documents 2
- e-mail address 206
- files 1
- online help 6, 202, 207
- Web sites xx

restrictions

- AIX 28
- DS4300 8
- EXP100 229
- firmware 5, 8, 9, 15, 37, 88, 91, 92, 113, 116, 167, 169, 229
- in-band (host-agent) management 9
- Red Hat Linux 153
- SUSE Linux 153

RHEL

- See* Linux (Red Hat)

runtime software

- package info 4

## S

SAN boot with AIX 34

- installation procedure 34
- preparing for installation 34

SAN-attached configuration 28, 45, 99, 123, 154, 155

SATA 5, 24

Script Editor

- Diagnostic Data Capture 247

sending your comments to IBM xxii

services offered in the U.S.A. 263

setting

- IP addresses 13
- NMS for SNMP notification 206

Simple Network Management Protocol (SNMP)

- notification 206

Simple Network Management Protocol (SNMP)

- traps 12, 13

SLES

- See* Linux (SUSE)

SMagent

- description 5
- installing
  - AIX 33
  - HP-UX 88
  - Red Hat Linux 167
  - Solaris 113
- software installation sequence 5

SMclient

- components 5
- description 4
- Enterprise Management window 5
- installing
  - AIX 32
  - HP-UX 87
  - Red Hat Linux 166
  - Solaris 112
- software installation sequence 5
- Subsystem Management window 5

SMesm

- installing
  - AIX 32
  - HP-UX 87
  - Red Hat Linux 166
  - Solaris 110

SMruntime

- description 4
- installing
  - AIX 32
  - HP-UX 86
  - Red Hat Linux 165
  - Solaris 110
- software installation sequence 5

SMutil

- description 5
- installing
  - AIX 33
  - HP-UX 89
  - Red Hat Linux 167
  - Solaris 114
- software installation sequence 5

snapware

- AIX firmware 20
- HP-UX firmware 20
- Red Hat Linux firmware 20
- Solaris firmware 20
- SUSE Linux firmware 20

SNMP

- notification 206
- traps 12

SNMP traps 13

software package

- RDAC 30, 134, 175
- SMagent 5
- SMclient 4

- software package *(continued)*
  - SMruntime 4
  - SMutil 5
- software requirements
  - AIX 27
  - HP-UX 83
  - Red Hat Linux 153
  - Solaris 107
  - SUSE Linux 151
- Solaris
  - client software 109, 110
  - cluster services requirements 210, 211
  - concurrent firmware download 116
  - configuration of storage subsystem 115
  - direct-attached configuration 123
  - DMP 144, 147
  - Emulex host bus adapter cards 123
  - firmware
    - requirements 20
    - upgrading 118
  - hardware requirements 20, 107
  - host software 113
  - JNI host bus adapter cards 123, 125
  - logical drives, redistributing in case of failure 149
  - NVSRAM
    - requirements 20
    - upgrading 119
  - QLogic host bus adapter cards 123
  - RDAC driver
    - installing 142
    - requirements 113
  - requirements
    - client software 109
    - cluster services 210
    - firmware 20
    - hardware 20, 107
    - host software 113
    - NVSRAM 20
    - RDAC driver 113
    - software 107
    - system 107
  - SAN-attached configuration 123
  - SMagent, installing 113
  - SMclient, installing 112
  - SMesm, installing 110
  - SMruntime, installing 110
  - SMutil, installing 114
  - software requirements 107
  - staged controller firmware download 116
  - system requirements 107
  - VERITAS 144, 147
- staged controller firmware download
  - AIX 37
  - HP-UX 91
  - Red Hat Linux 169
  - Solaris 116
- storage area network (SAN)
  - configuration
    - AIX 45
    - HP-UX 99
    - Red Hat Linux 155
  - storage area network (SAN) *(continued)*
    - configuration *(continued)*
      - Solaris 123
      - technical support Web site xxi
    - storage expansion enclosures
      - EXP100 5, 20, 24
      - EXP500 20
      - EXP700 20
      - EXP700/710 20
      - EXP810 20
    - storage management station 6
      - description 3
    - Storage Manager
      - Controller Firmware Upgrade Tool
        - using the tool 235
    - Storage Manager software
      - installation sequence 5
      - introduction 3
      - list of software packages 4
      - removing previous versions 165
      - where to obtain 6
    - Storage Partitioning
      - AIX restrictions 29
      - and host groups
        - AIX 40
        - HP-UX 95
        - Red Hat Linux 172
        - Solaris 119
        - SUSE Linux 172
      - max. number of LUNs per partition 14
      - Red Hat Linux restrictions 154
      - SUSE Linux restrictions 154
    - storage subsystem
      - adding to SMclient
        - AIX 35
        - HP-UX 90
        - Red Hat Linux 168
        - Solaris 115
        - SUSE Linux 168
      - cluster services 209
      - configuring
        - AIX 35
        - HP-UX 90
        - procedures 201
        - Solaris 115
      - initial automatic discovery 201
      - introduction 3
      - logical drives
        - identifying by operating system device names 57
      - management methods
        - example showing both types 12
        - in-band (host-agent) 9
        - out-of-band (direct) 10
      - management tasks 207
      - profile, saving 202, 206
      - renaming 206
    - Subsystem Management window
      - description 5
      - online help 7
    - support notifications 3

SUSE Linux  
  See Linux (SUSE)  
switch  
  in a SAN-attached configuration 45, 99, 123, 155  
  modifying JNI HBA settings 125, 128  
  modifying QLogic HBA settings 134  
  technical support Web site xxi  
  zoning 45, 99, 123, 155  
switch environment 245  
system requirements  
  AIX 27  
  HP-UX 83  
  Red Hat Linux 153  
  Solaris 107  
  SUSE Linux 151

## T

tasks by document title 253  
tasks by documentation title 253  
trademarks 264

## U

universal transport mechanism  
  See utm device  
updates (product updates) 3  
upgrade tool  
  adding a storage subsystem 236  
  checking device health 235  
  downloading firmware 237  
  installing 236  
  overview 235  
  viewing log file 240  
upgrading  
  firmware  
    AIX 39  
    HP-UX 94  
    Red Hat Linux 171  
    Solaris 118  
    SUSE Linux 171  
  NVSRAM  
    AIX 40  
    HP-UX 94  
    Red Hat Linux 172  
    Solaris 119  
    SUSE Linux 172  
util software  
  AIX 33  
  Red Hat Linux 167  
utility software  
  package info 5  
utm device 48

## V

variable settings for JNI adapter cards 125  
VERITAS  
  Cluster Server 210  
  Dynamic Multipathing (DMP) 134, 144, 145, 147,  
  210

VERITAS (*continued*)  
  Enterprise Administrator 147  
  File System 144, 147  
  VolumeManager 134, 144, 147, 210  
Virtual I/O Server 27

## W

Web sites  
  AIX fix delivery center xxi, 47  
  downloading AIX file sets 47  
  DS4000 interoperability matrix xxi  
  DS4000 storage subsystems xx  
  DS4000 technical support xxi, 20  
  IBM publications center xxi  
  IBM System Storage products xx  
  list xx  
  premium feature activation xxi  
  readme files xx, 20  
  SAN support xxi  
  Solaris failover driver info 144  
  Solaris HBA driver info 124, 133  
  switch support xxi

## Z

zoning 245  
zoning switches 45, 99, 123, 155

---

# Readers' Comments — We'd Like to Hear from You

**IBM System Storage DS4000 Storage Manager Version 10  
Installation and Host Support Guide for AIX, HP-UX, Solaris, and Linux on POWER**

**Publication No. GC27-2170-00**

We appreciate your comments about this publication. Please comment on specific errors or omissions, accuracy, organization, subject matter, or completeness of this book. The comments you send should pertain to only the information in this manual or product and the way in which the information is presented.

For technical questions and information about products and prices, please contact your IBM branch office, your IBM business partner, or your authorized remarketer.

When you send comments to IBM, you grant IBM a nonexclusive right to use or distribute your comments in any way it believes appropriate without incurring any obligation to you. IBM or any other organizations will only use the personal information that you supply to contact you about the issues that you state on this form.

Comments:

Thank you for your support.

Submit your comments using one of these channels:

- Send your comments to the address on the reverse side of this form.

If you would like a response from IBM, please fill in the following information:

\_\_\_\_\_  
Name

\_\_\_\_\_  
Address

\_\_\_\_\_  
Company or Organization

\_\_\_\_\_  
Phone No.

\_\_\_\_\_  
E-mail address



Fold and Tape

Please do not staple

Fold and Tape



NO POSTAGE  
NECESSARY  
IF MAILED IN THE  
UNITED STATES

# BUSINESS REPLY MAIL

FIRST-CLASS MAIL PERMIT NO. 40 ARMONK, NEW YORK

POSTAGE WILL BE PAID BY ADDRESSEE

International Business Machines Corporation  
Information Development  
Department GZW  
9000 South Rita Road  
Tucson, Arizona  
USA 85744-0001



Fold and Tape

Please do not staple

Fold and Tape







Printed in USA

GC27-2170-00



Spine information:



IBM System Storage DS4000  
Storage Manager Version 10

DS4000 Storage Manager Version 10 Installation and  
Support Guide for AIX, HP-UX, Solaris, and Linux on  
POWER