

QTY.	DESCRIPTION
1	Screen Assembly
1	Cover Assembly
27	Top Bar
1	Top Bar Main Assembly

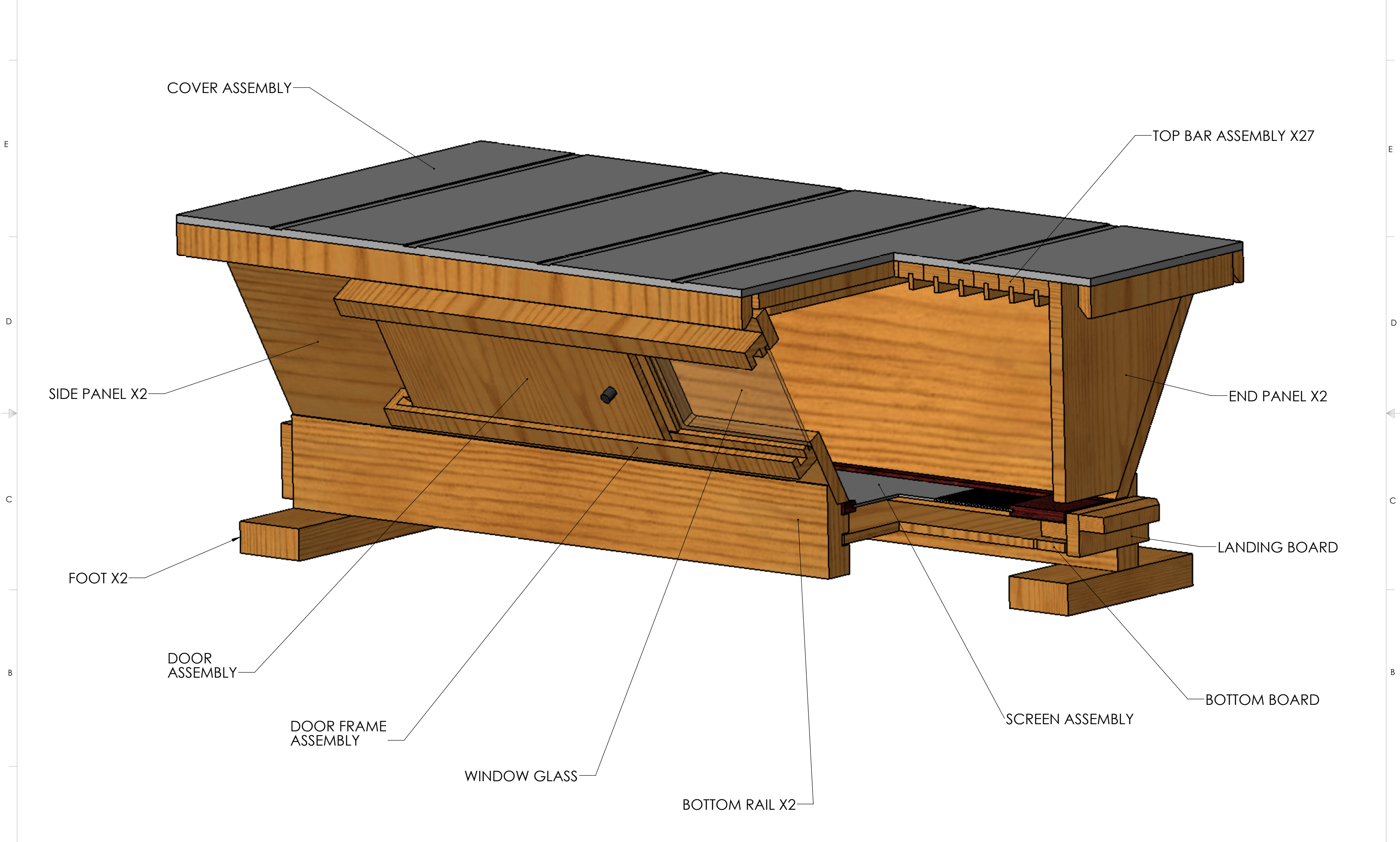

**THE BEE'S KNEE'S APIARY**

TITLE: TOP BAR BEE HIVE

UNLESS OTHERWISE SPECIFIED:		AUTHOR: T.J. CARR		DATE: 02/22/07	
DIMENSIONS ARE IN INCHES		MATERIAL: SEE B.O.M.S		DWG. NO. 001	
TOLERANCES:		FINISH: SEE NOTES		REV X	
FRACTIONAL: ± 1/16				DO NOT TO SCALE	
ANGULAR: MACH ± 1°				SHEET 1 OF 9	
TWO PLACE DECIMAL ± .03					

ITEM NO.	QTY.	StockSize
1	2	2" X 4" X 18" PINE
2	2	2" X 6" X 42" PINE
3	2	1" X 12" X 42" PINE
4	2	1" X 12" X 19-1/2" PINE
17	1	1" X 2" X 10" PINE

**PROPRIETARY AND CONFIDENTIAL**  
 THE INFORMATION CONTAINED IN THIS DRAWING IS THE SOLE PROPERTY OF <INSERT COMPANY NAME HERE>. ANY REPRODUCTION IN PART OR AS A WHOLE WITHOUT THE WRITTEN PERMISSION OF <INSERT COMPANY NAME HERE> IS PROHIBITED.

1. ADJUST END PLATE DIMENSION TO ALLOW A 3/8 GAP ABOVE LANDING BOARD.

2. PAINT ALL EXTERIOR SURFACES WITH WHITE OIL BASE EXTERIOR ENAMEL.

3. INTERIOR LIVING SPACE SURFACES NATURAL WOOD FINISH.

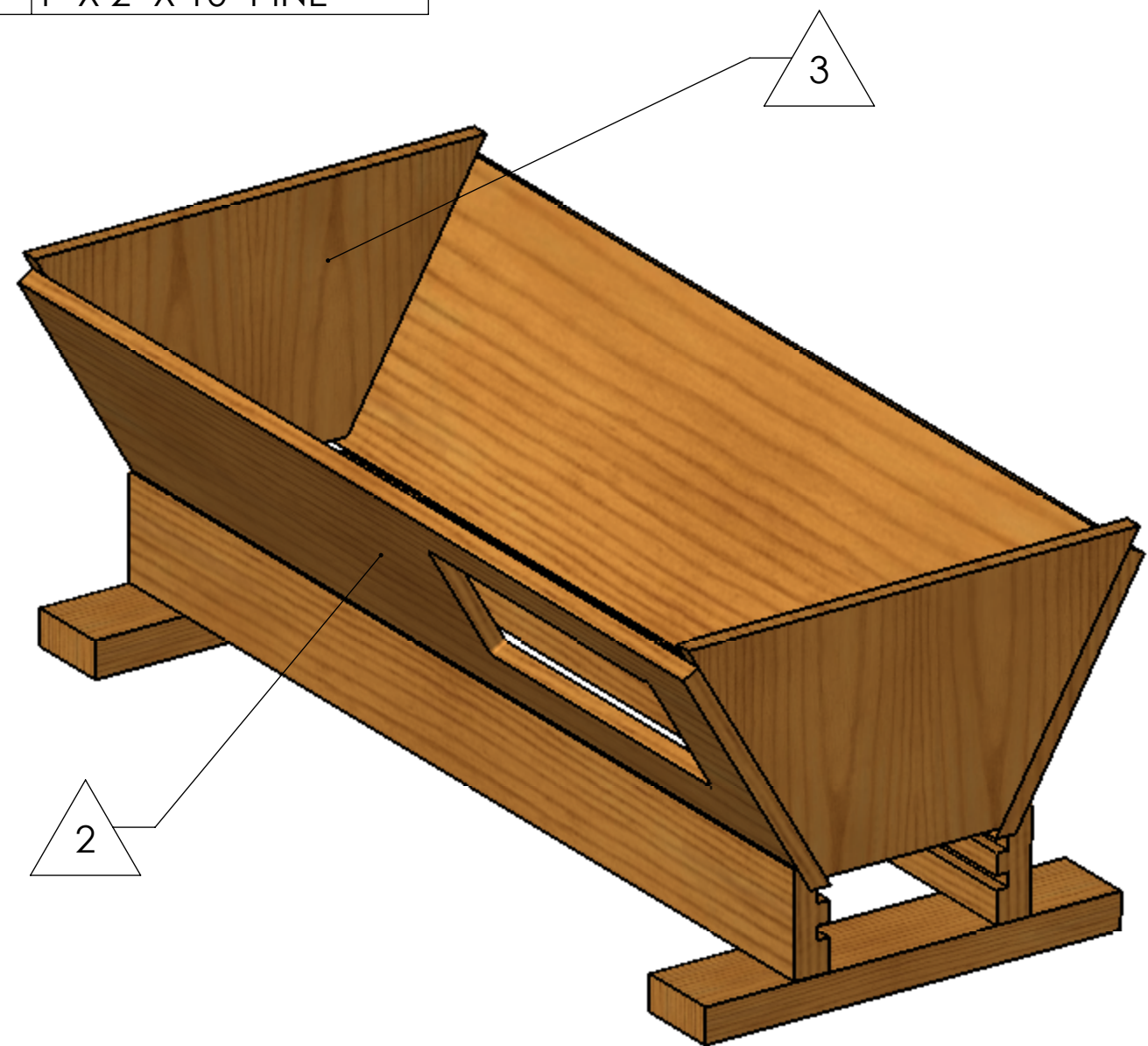

MAIN HIVE ASSEMBLY

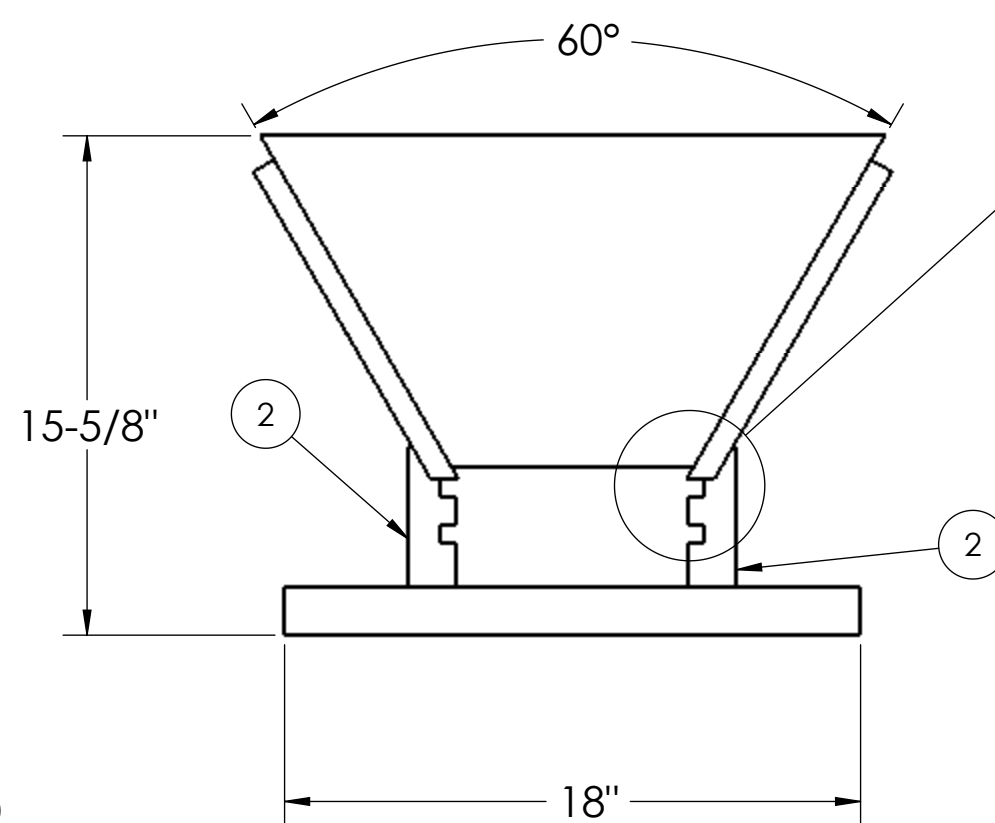
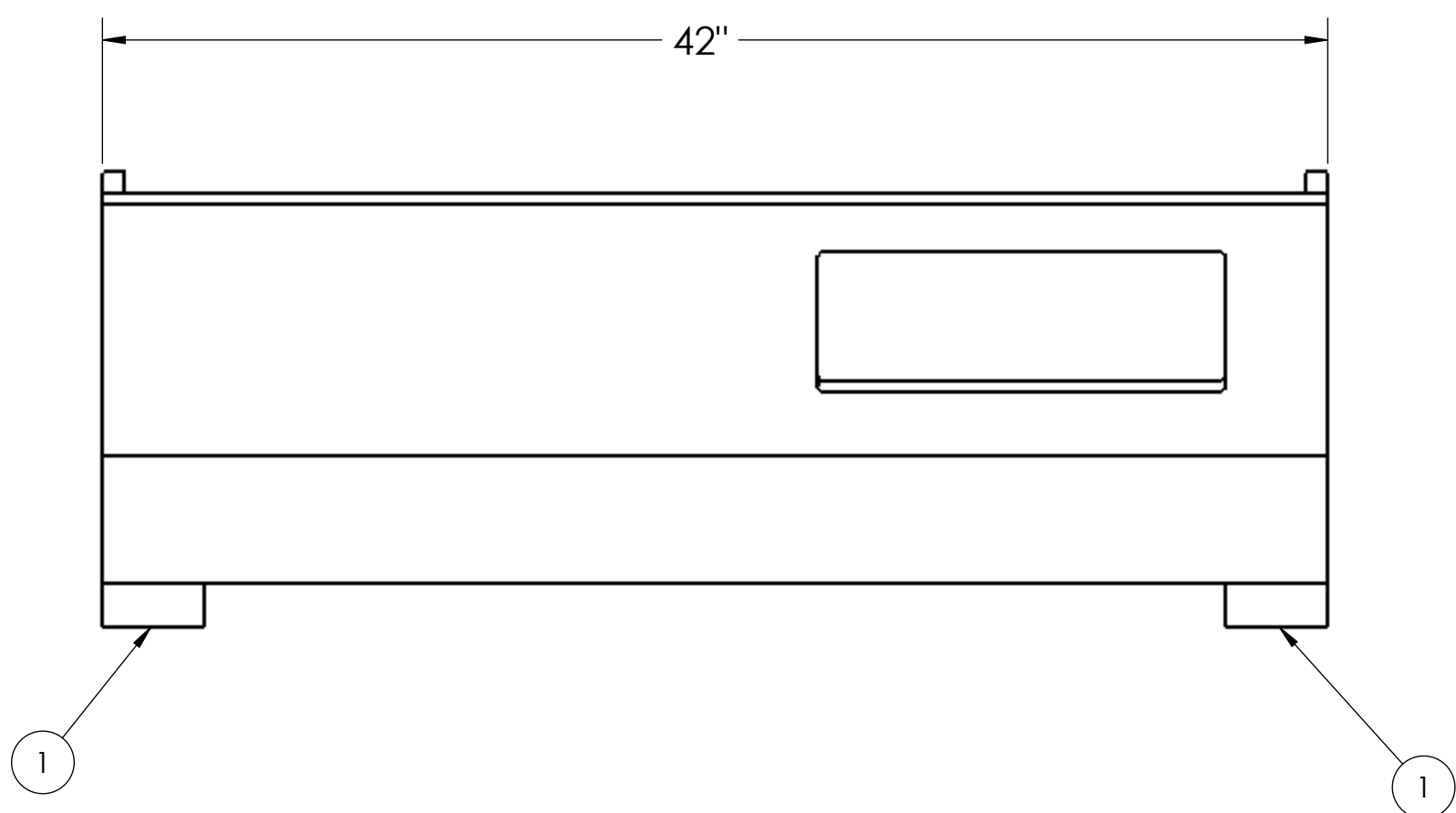
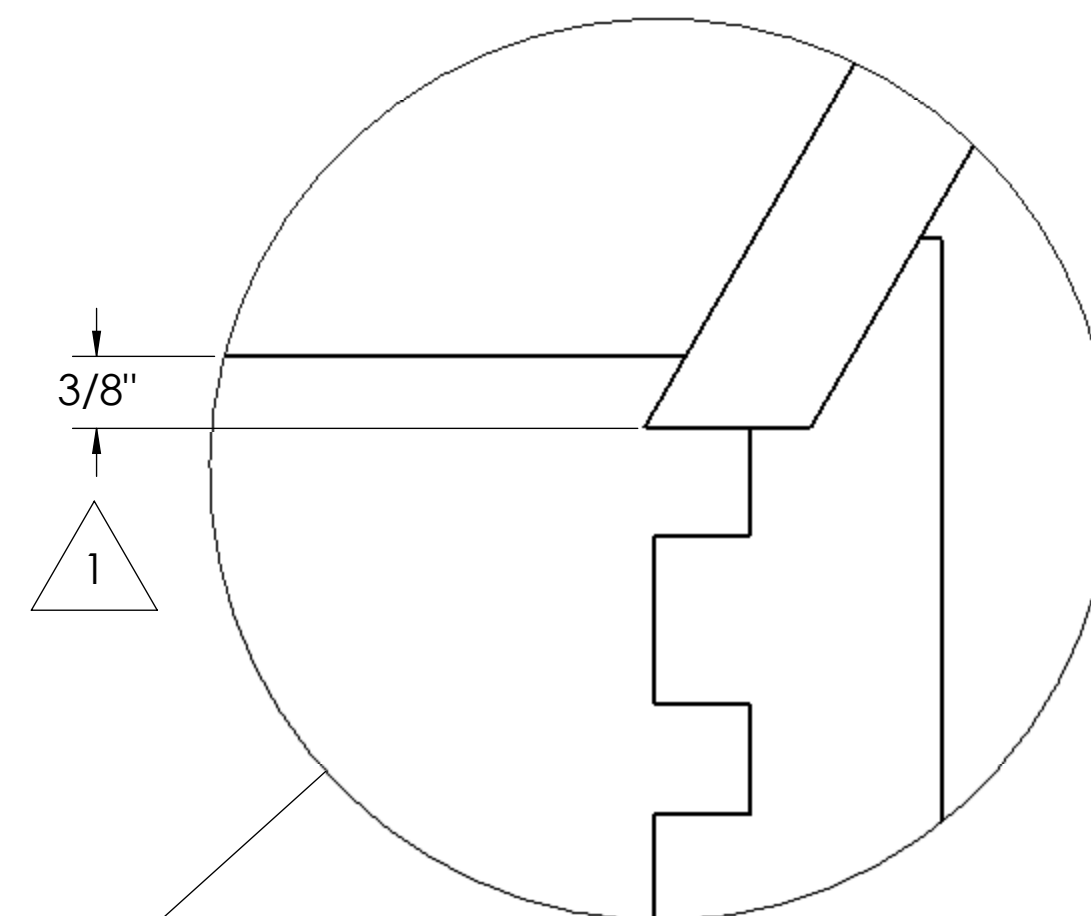
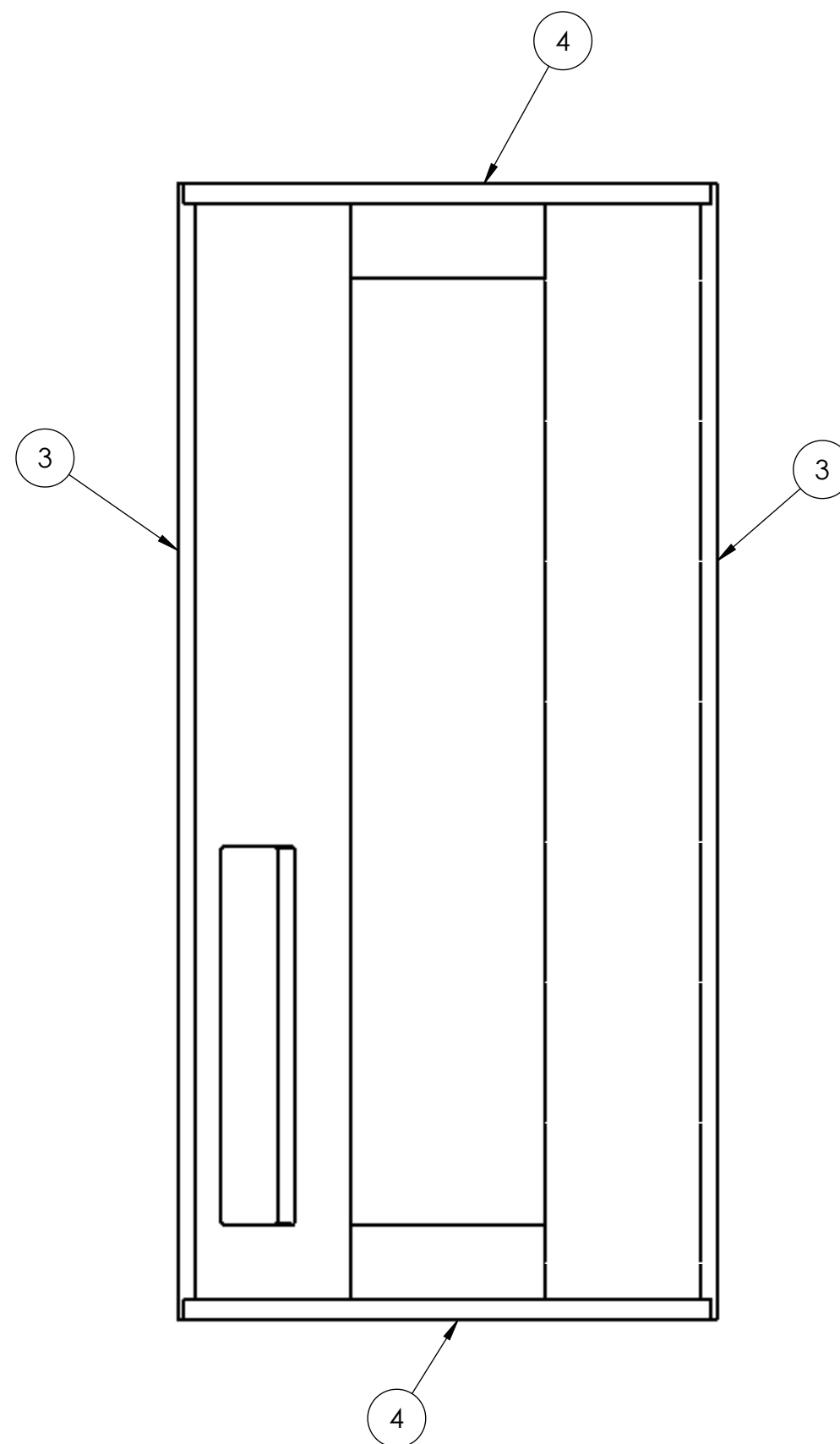

**THE BEE'S KNEE'S APIARY**

TITLE: TOP BAR BEE HIVE

UNLESS OTHERWISE SPECIFIED:  
 DIMENSIONS ARE IN INCHES  
 TOLERANCES:  
 FRACTIONAL: ± 1/16  
 ANGULAR: MACH ± 1°  
 TWO PLACE DECIMAL ± .03

AUTHOR: T.J. CARR  
 MATERIAL: SEE B.O.M.S  
 FINISH: SEE NOTES

DATE: 02/22/07  
 DWG. NO. 001  
 DO NOT TO SCALE  
 REV X  
 SHEET 2 OF 9

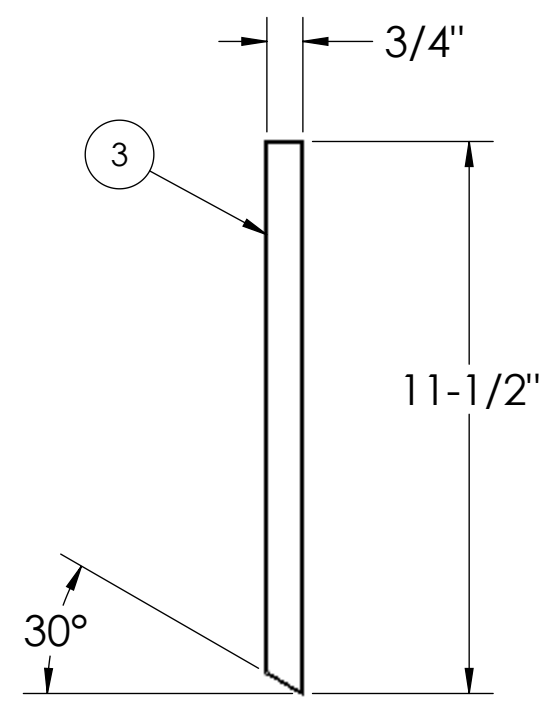
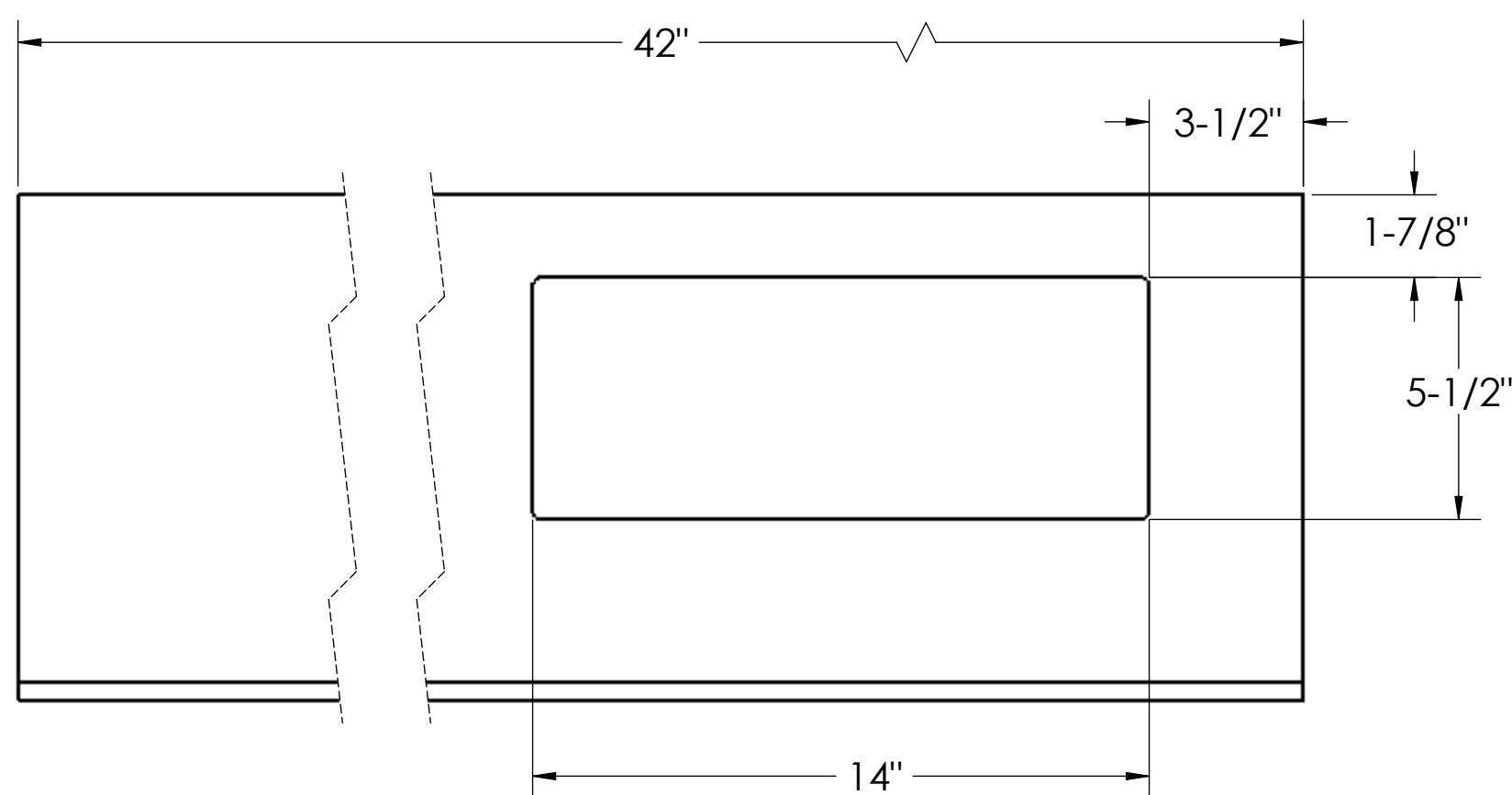

SIDE PANEL X2

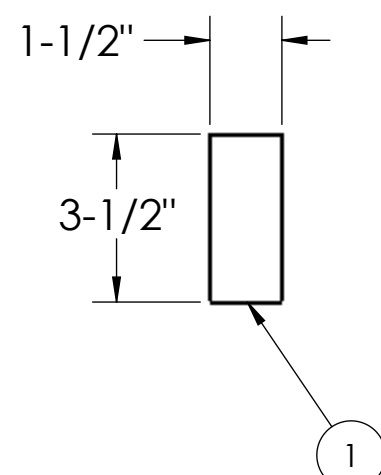
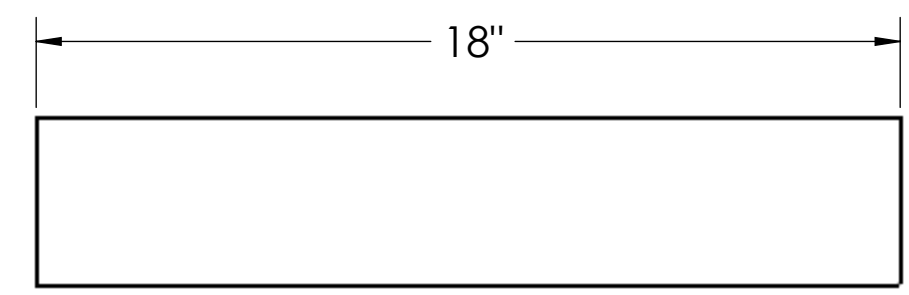

FOOT X2

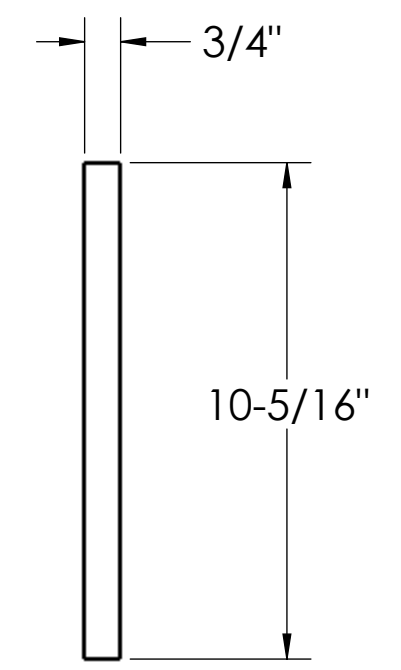
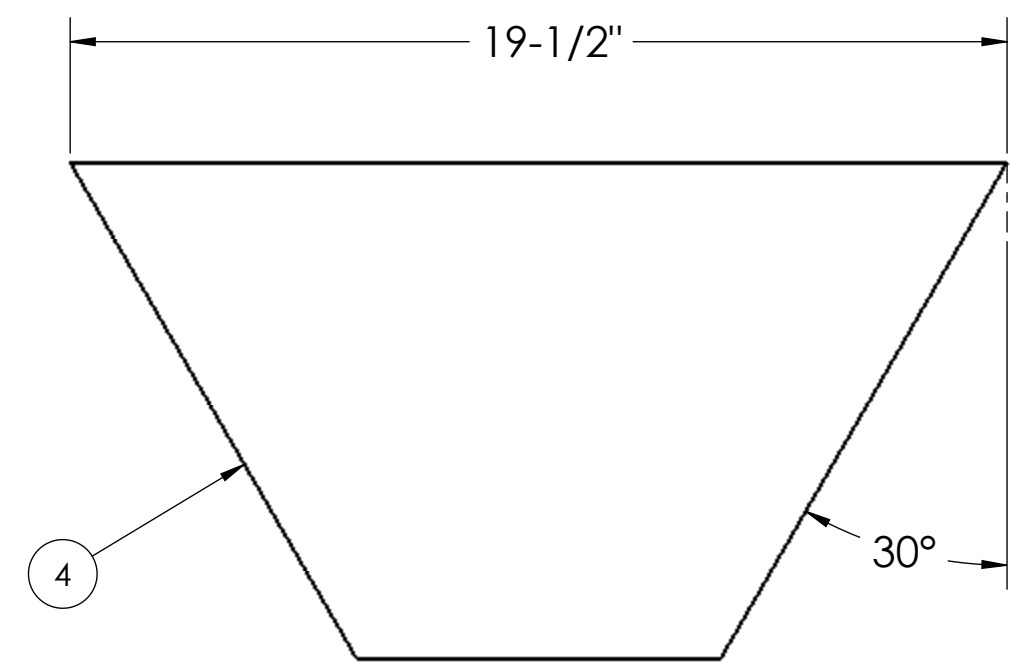

END PANEL X2

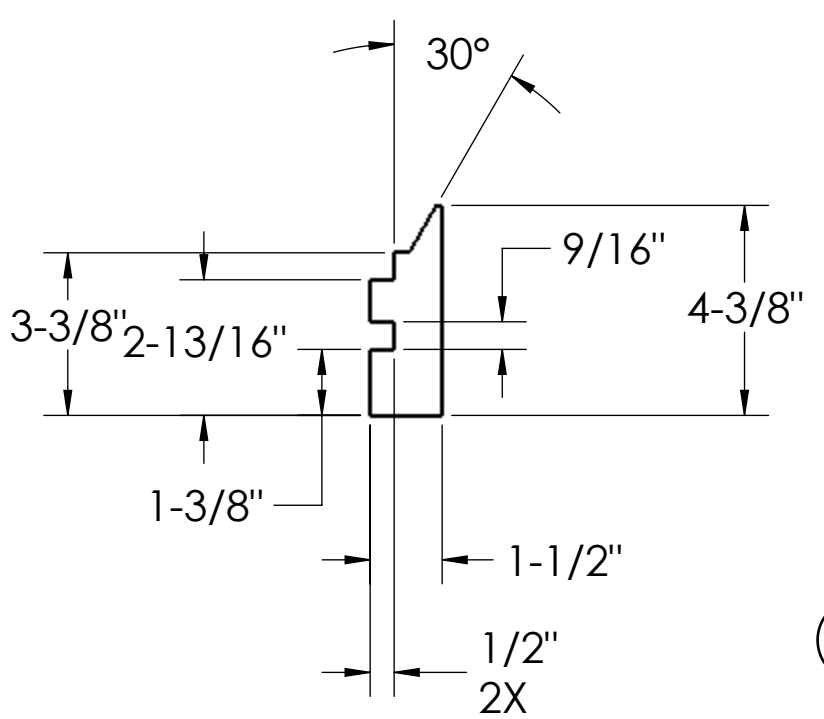
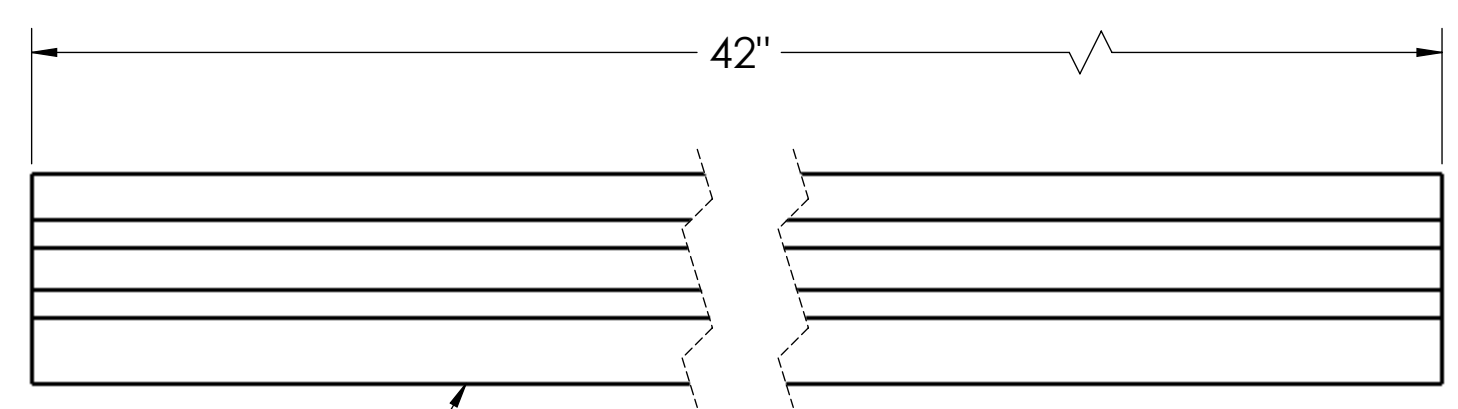

BOTTOM RAIL X2

**THE BEE'S KNEE'S APIARY**

TITLE: TOP BAR BEE HIVE

UNLESS OTHERWISE SPECIFIED:		DATE: 02/22/07	
DIMENSIONS ARE IN INCHES	AUTHOR: T.J. CARR	DWG. NO. 001	REV X
TOLERANCES:	MATERIAL: SEE B.O.M.S	DO NOT TO SCALE	SHEET 3 OF 9
FRACTIONAL: ± 1/16	FINISH: SEE NOTES		
ANGULAR: MACH ± 1°			
TWO PLACE DECIMAL ± .03			

ITEM NO.	QTY.	StockSize
1	1	3/8" X 22" X 45-1/2" HARDIPANEL
2	2	1" X 2" X 20-1/2" PINE
3	2	1" X 2" X 45-1/2" PINE

2 PAINT ALL EXTERIOR SURFACES WITH WHITE OIL BASE EXTERIOR ENAMEL.

PROPRIETARY AND CONFIDENTIAL  
THE INFORMATION CONTAINED IN THIS DRAWING IS THE SOLE PROPERTY OF <INSERT COMPANY NAME HERE>. ANY REPRODUCTION IN PART OR AS A WHOLE WITHOUT THE WRITTEN PERMISSION OF <INSERT COMPANY NAME HERE> IS PROHIBITED.

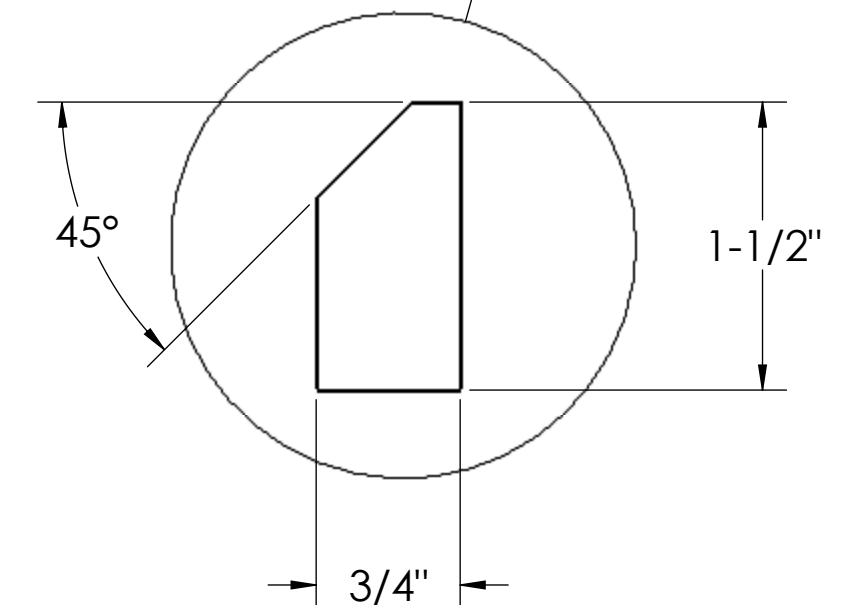
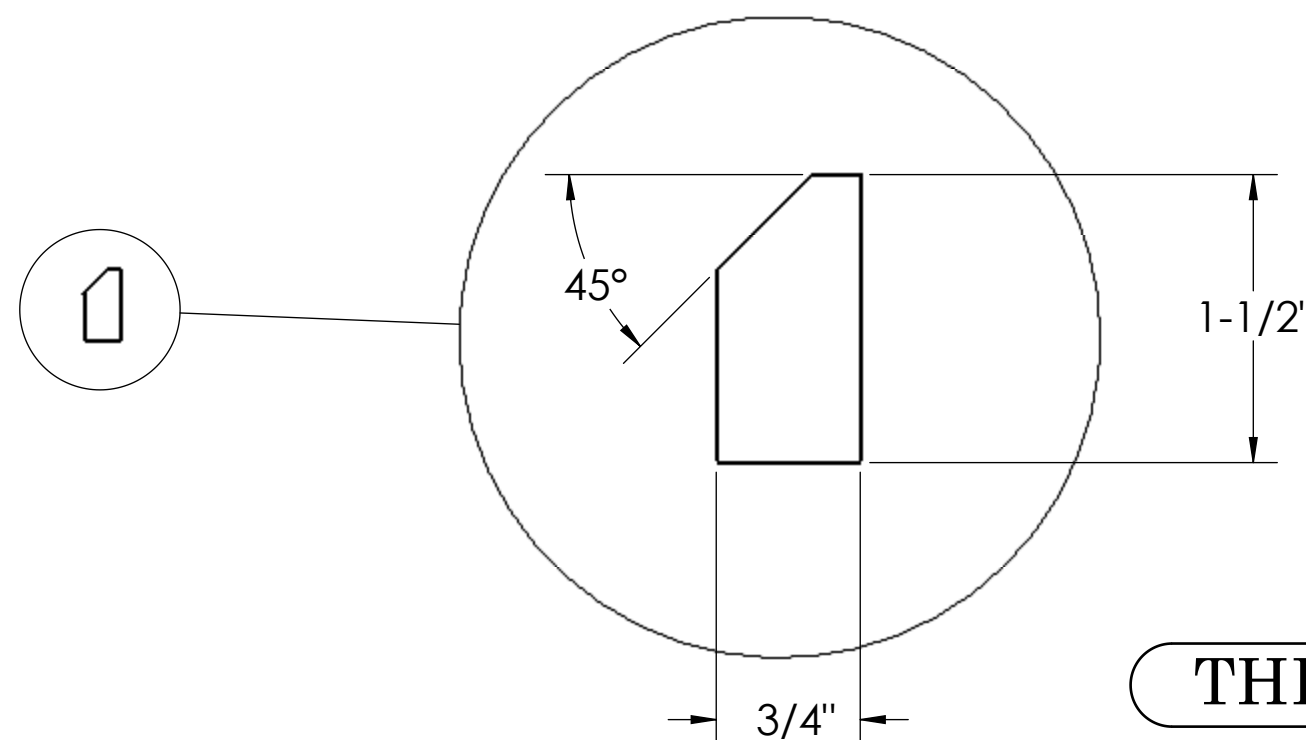
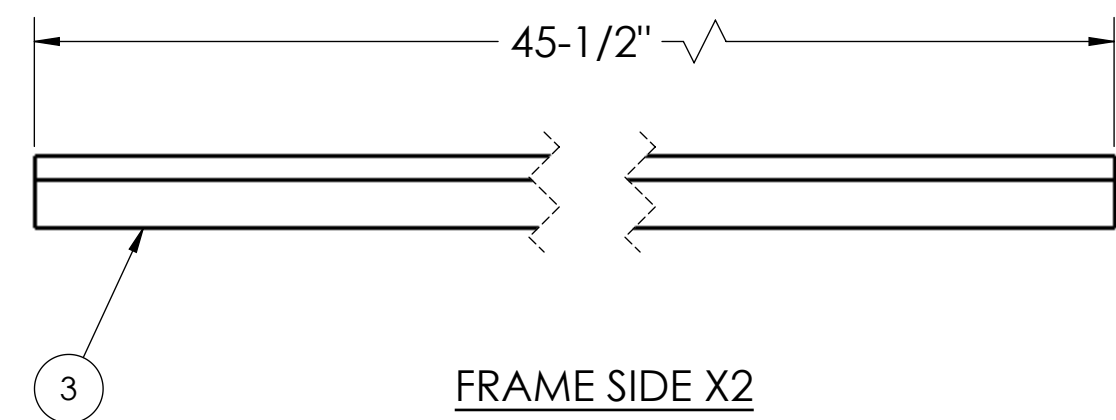
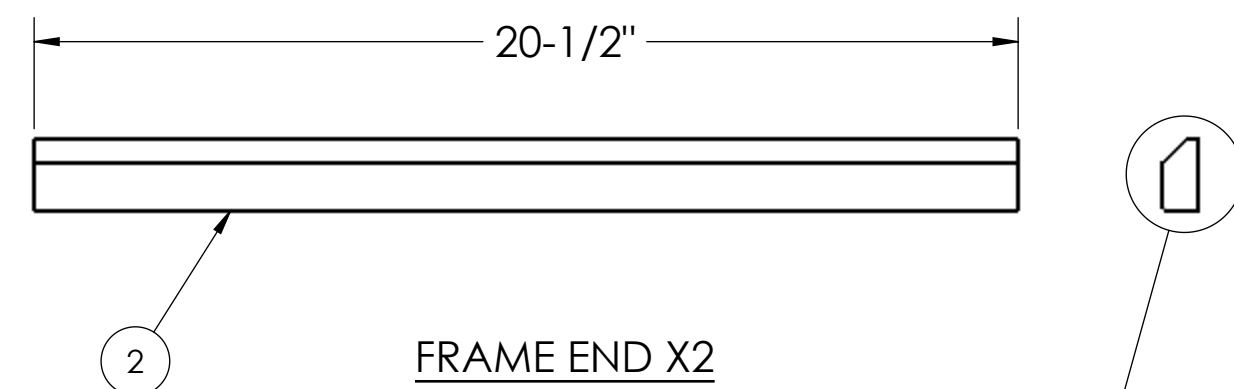
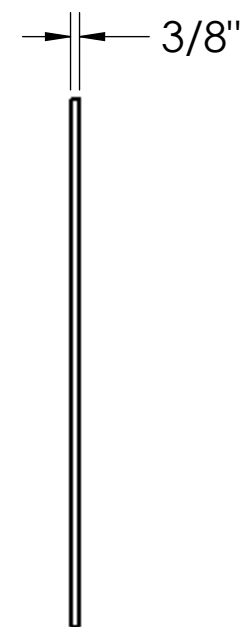
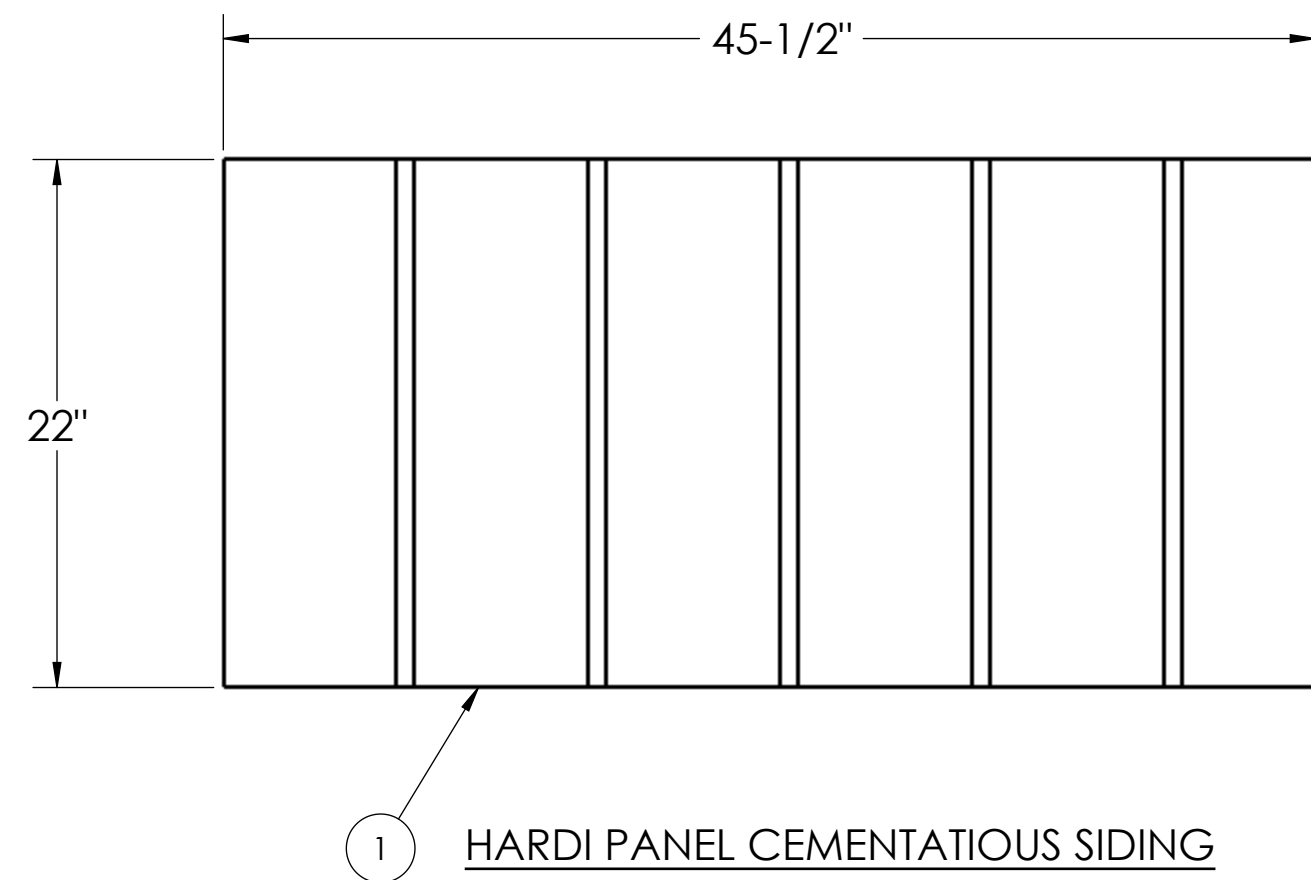
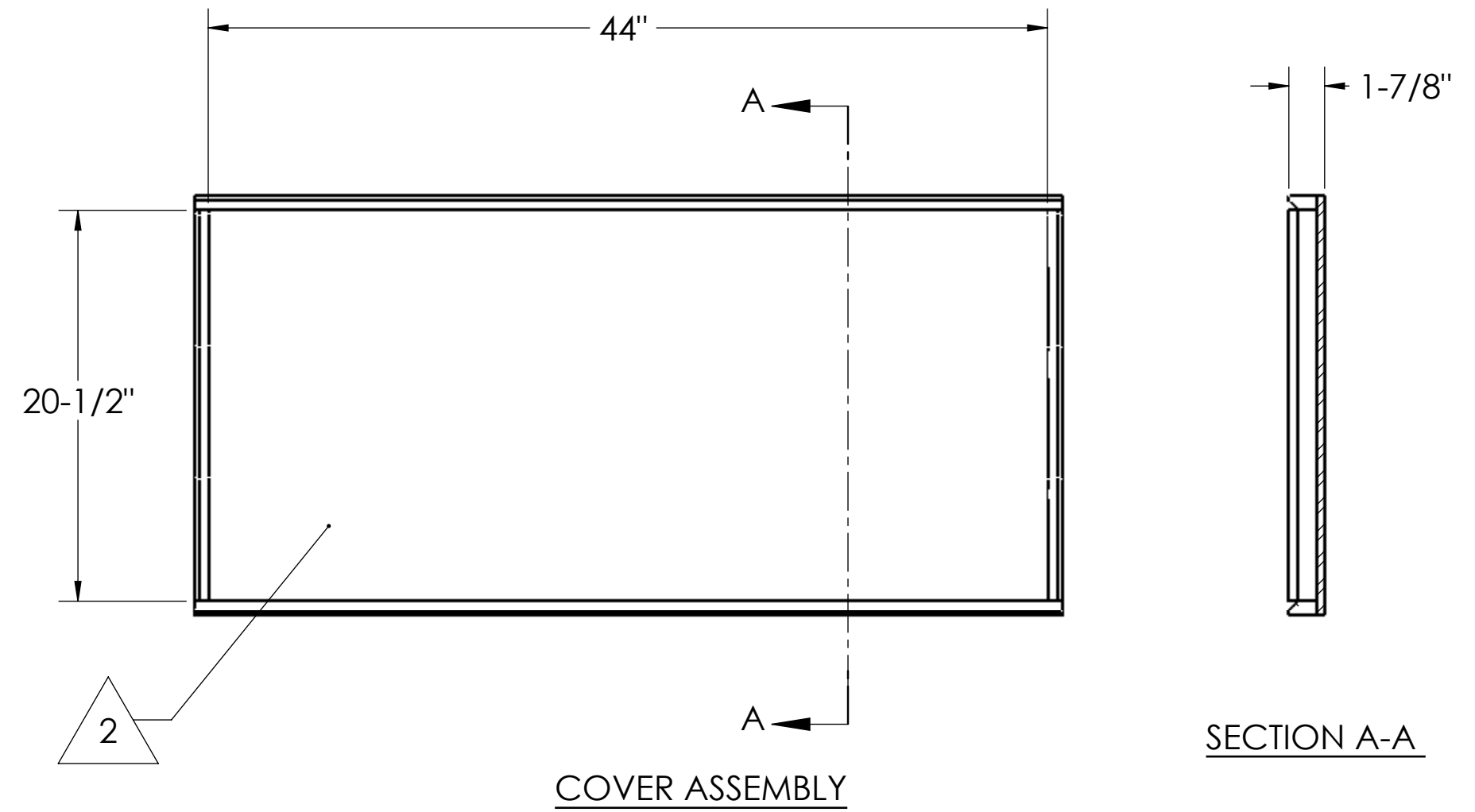
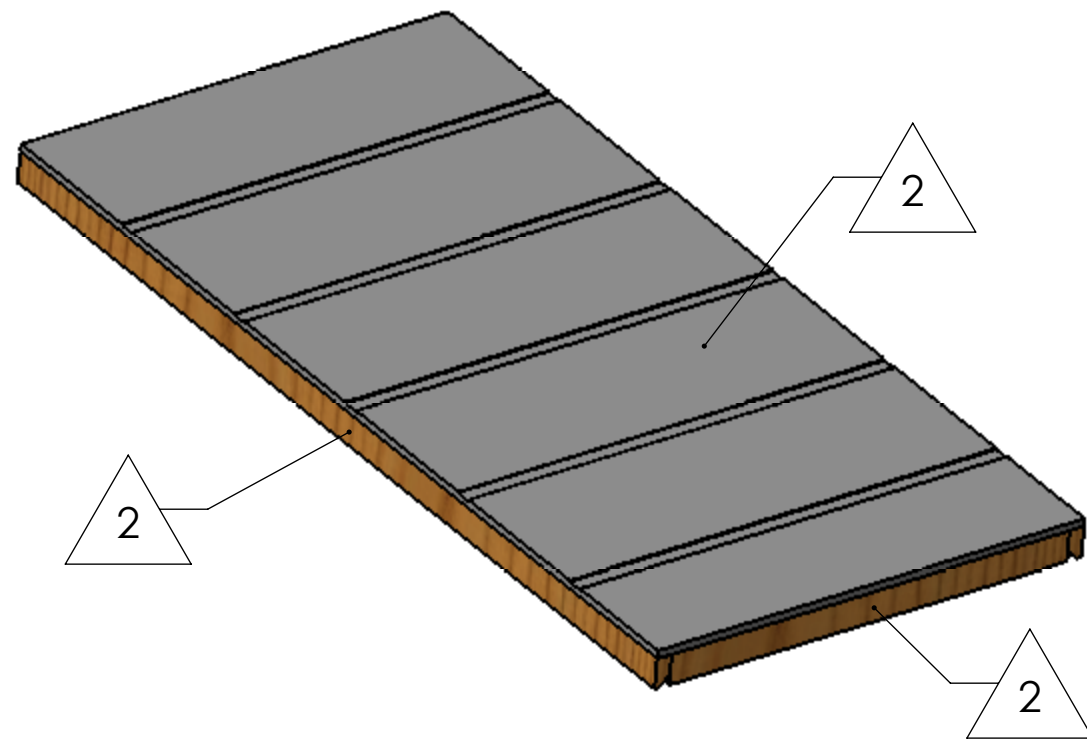

**THE BEE'S KNEE'S APIARY**

TITLE: TOP BAR BEE HIVE

UNLESS OTHERWISE SPECIFIED:		AUTHOR: T.J. CARR		DATE: 02/22/07
DIMENSIONS ARE IN INCHES		MATERIAL: SEE B.O.M.S		DWG. NO. 001
TOLERANCES:		FINISH: SEE NOTES		REV X
FRACTIONAL ± 1/16				DO NOT TO SCALE
ANGULAR: MACH ± 1°				SHEET 4 OF 9
TWO PLACE DECIMAL ± .03				

ITEM NO.	QTY.	StockSize
11	2	1" X 2" X 8" PINE
13	1	1" X 4" X 10" PINE
14	1	1/2" X 6-1/4" X 15" PLYWOOD
15	1	DOOR KNOB
20	1	1" X 2" X 8" PINE
21	1	1" X 2" X 10" PINE

**2** PAINT ALL EXTERIOR SURFACES WITH WHITE OIL BASE EXTERIOR ENAMEL.

**PROPRIETARY AND CONFIDENTIAL**  
 THE INFORMATION CONTAINED IN THIS DRAWING IS THE SOLE PROPERTY OF <INSERT COMPANY NAME HERE>. ANY REPRODUCTION IN PART OR AS A WHOLE WITHOUT THE WRITTEN PERMISSION OF <INSERT COMPANY NAME HERE> IS PROHIBITED.

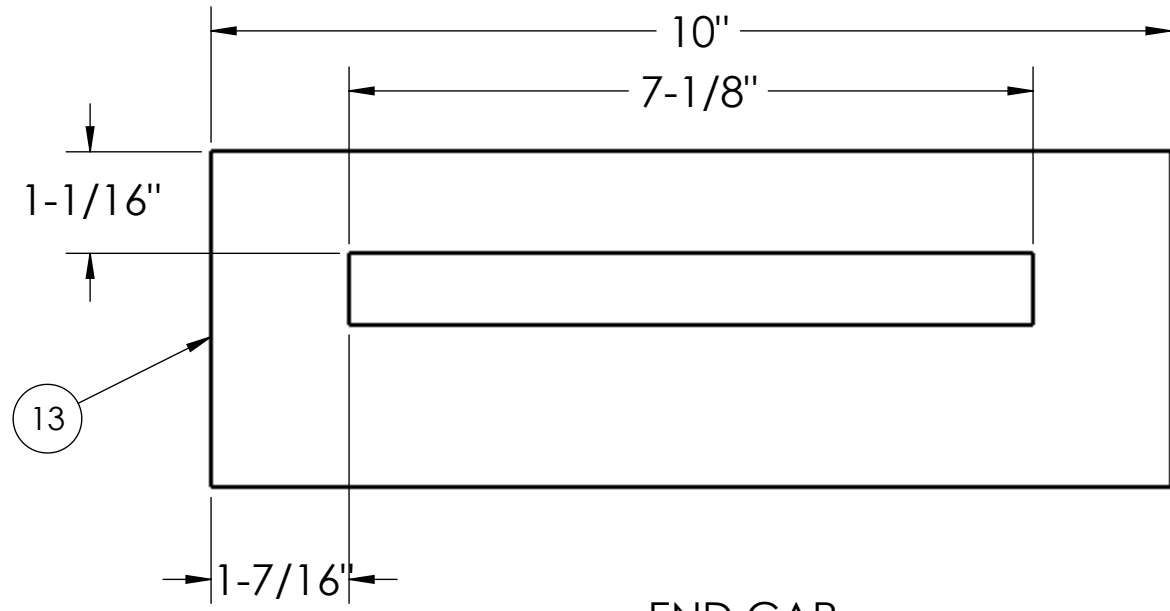

END CAP

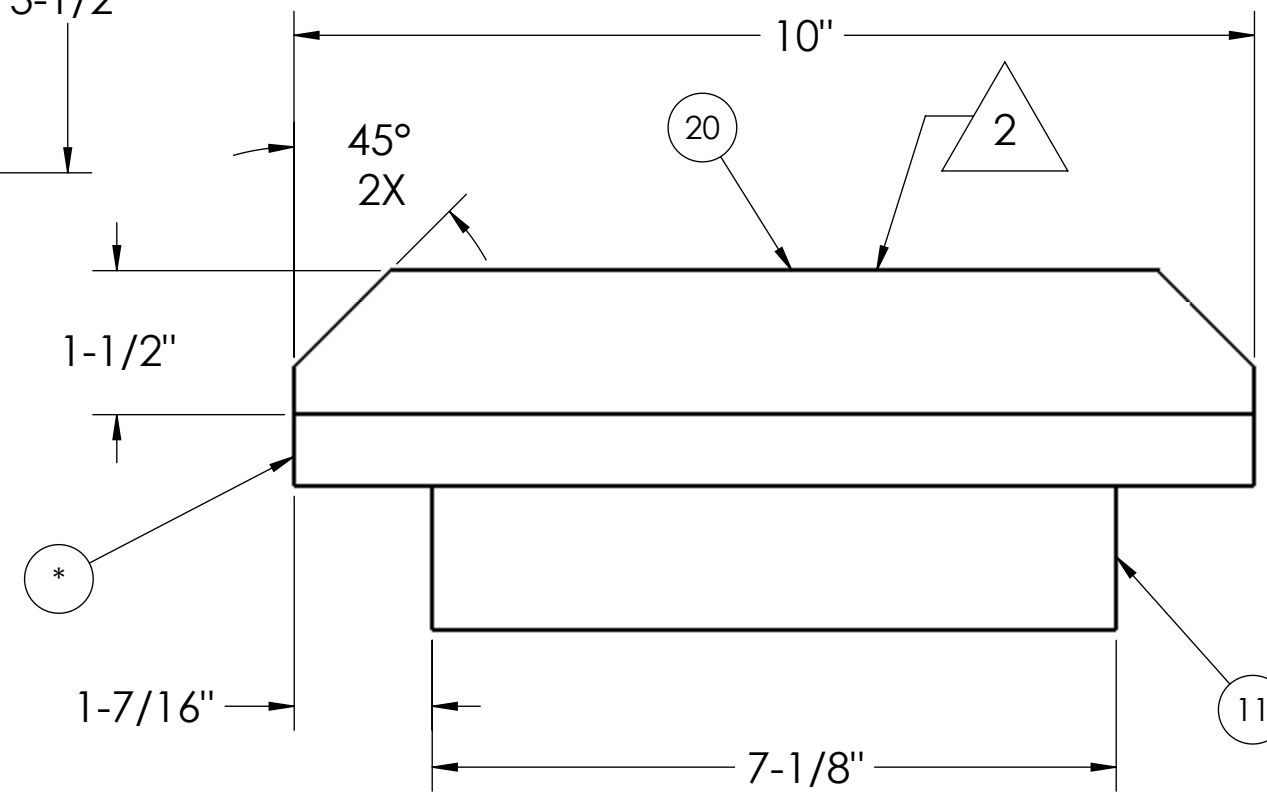
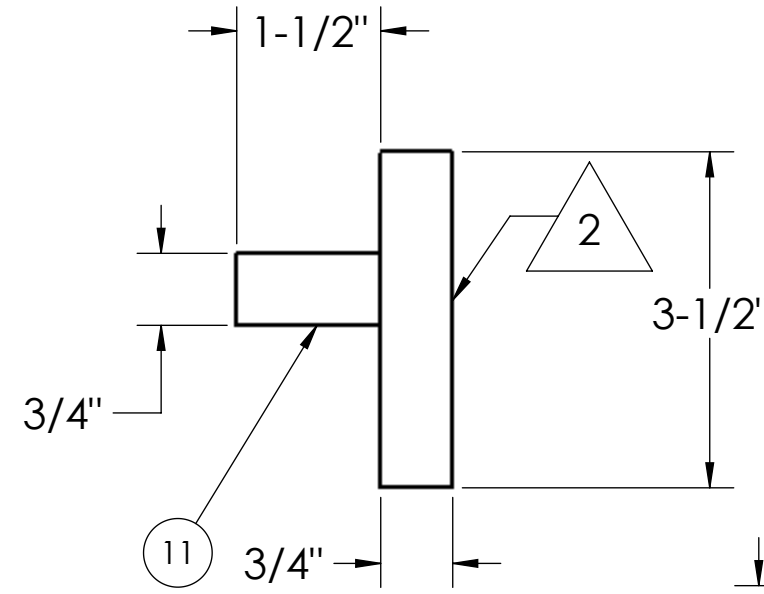

LANDING BOARD

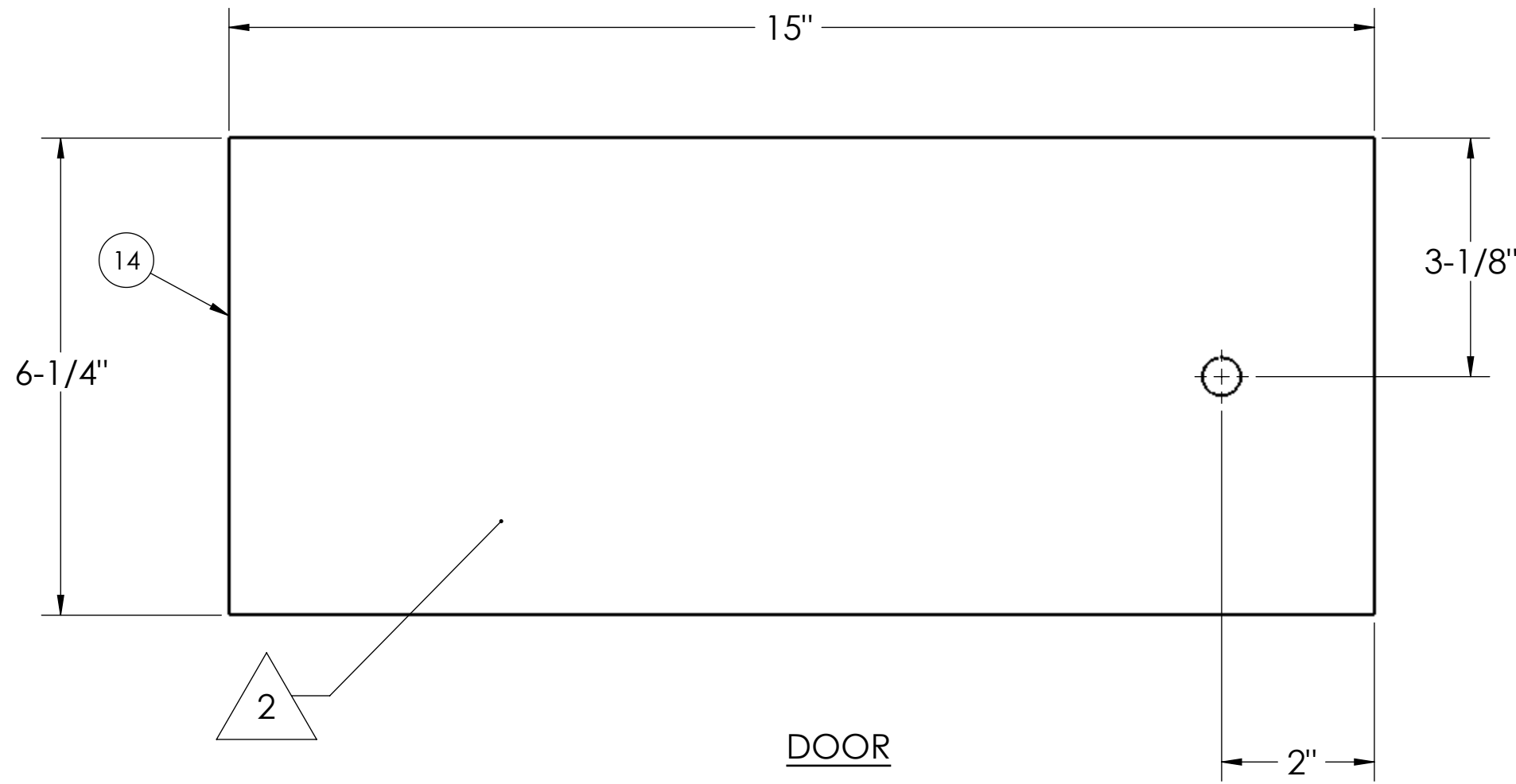
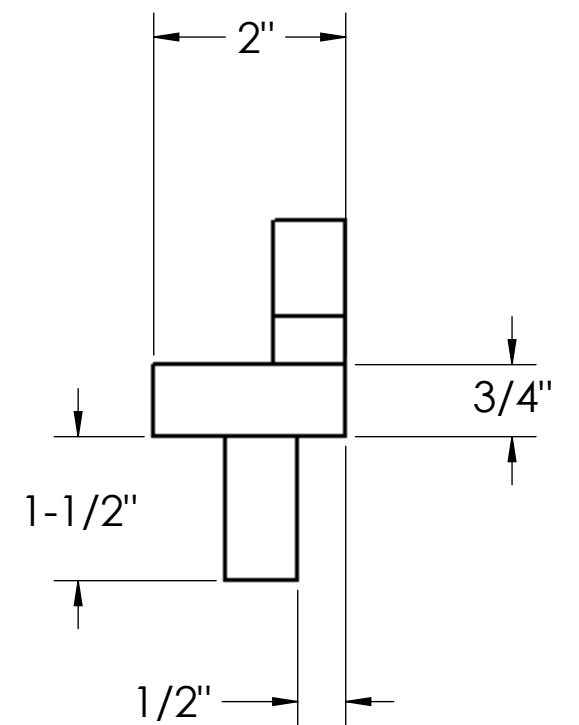

DOOR

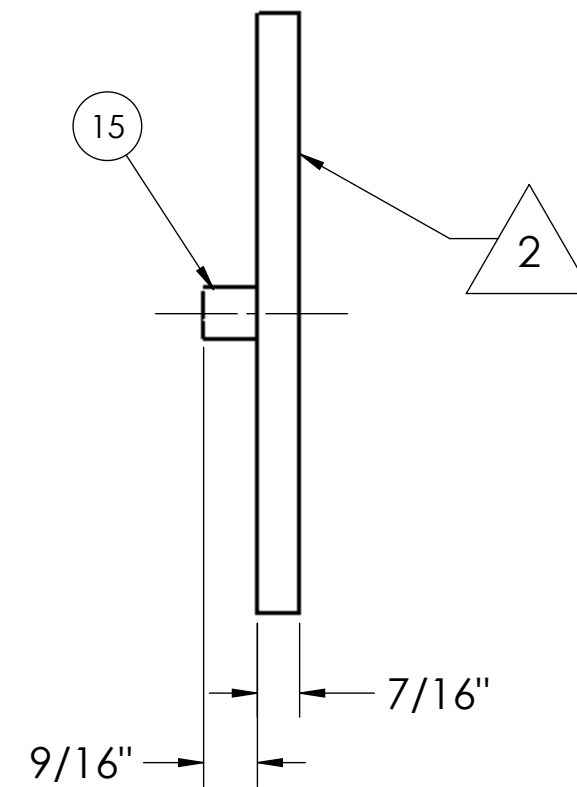

**THE BEE'S KNEE'S APIARY**

TITLE: TOP BAR BEE HIVE

UNLESS OTHERWISE SPECIFIED:		DATE: 02/22/07	
DIMENSIONS ARE IN INCHES	AUTHOR: T.J. CARR	DWG. NO. 001	REV X
TOLERANCES: FRACTIONAL ± 1/16 ANGULAR: MACH ± 1° TWO PLACE DECIMAL ± .03	MATERIAL: SEE B.O.M.S	DO NOT TO SCALE	SHEET 5 OF 9
FINISH: SEE NOTES			

SOLIDWORKS DWG CHECKED BY:

ENGR.

4. ASSEMBLE WITH EXTERIOR GRADE GLUE.

5. DO NOT PAINT OR STAIN SCREEN ASSEMBLY.

PROPRIETARY AND CONFIDENTIAL  
THE INFORMATION CONTAINED IN THIS  
DRAWING IS THE SOLE PROPERTY OF  
<INSERT COMPANY NAME HERE>. ANY  
REPRODUCTION IN PART OR AS A WHOLE  
WITHOUT THE WRITTEN PERMISSION OF  
<INSERT COMPANY NAME HERE> IS  
PROHIBITED.

ITEM NO.	QTY.	StockSize
1	1	#6 x 6" X 36" STEEL SCREEN
2	2	1/2" X 3-1/2" X 6-1/4" HARDWOOD
3	2	1/2" X 3/4" X 41-3/4" HARDWOOD
4	4	1/8" X 1/2" X 3" MASONITE

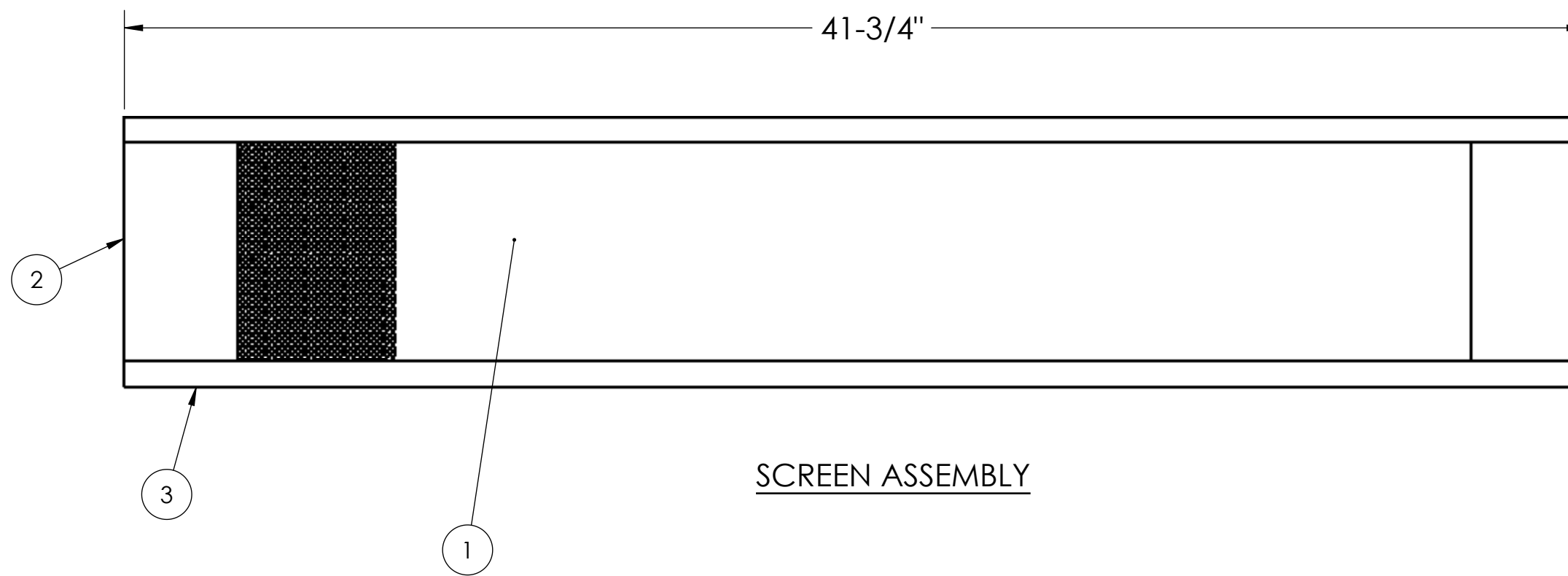
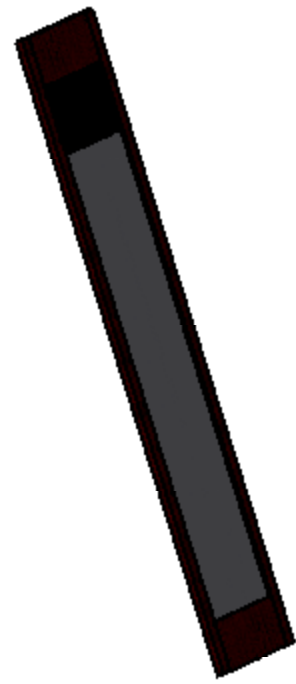

SCREEN ASSEMBLY

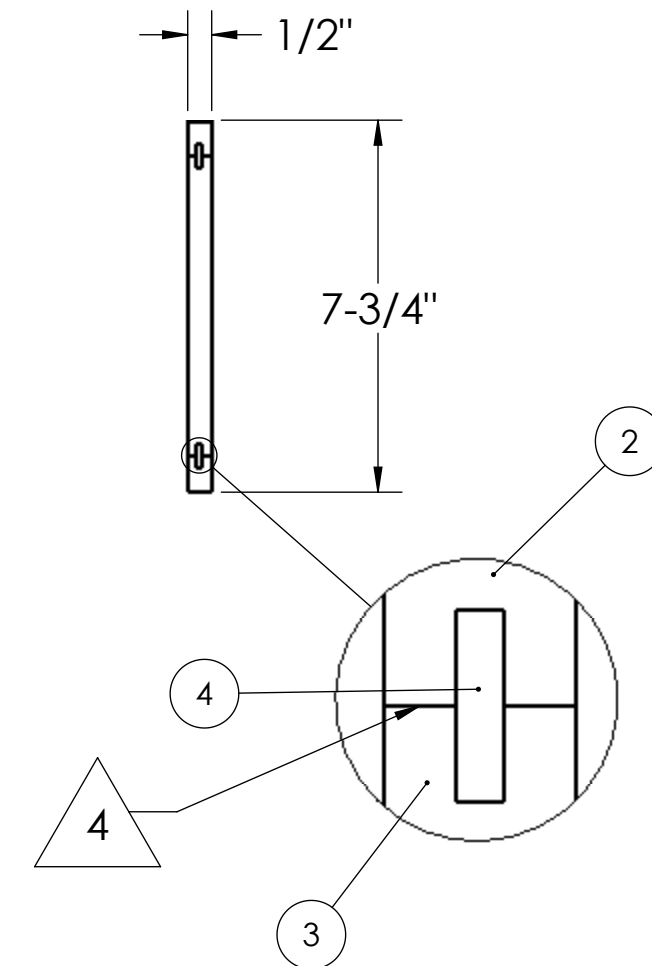

MASONITE INSERT IN PLACE  
4X

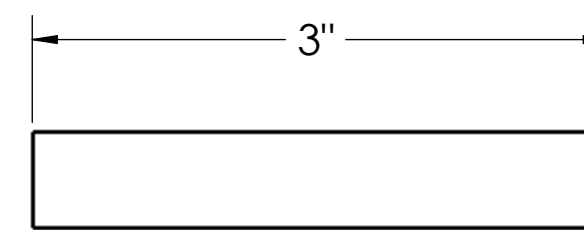

MASONITE INSERT

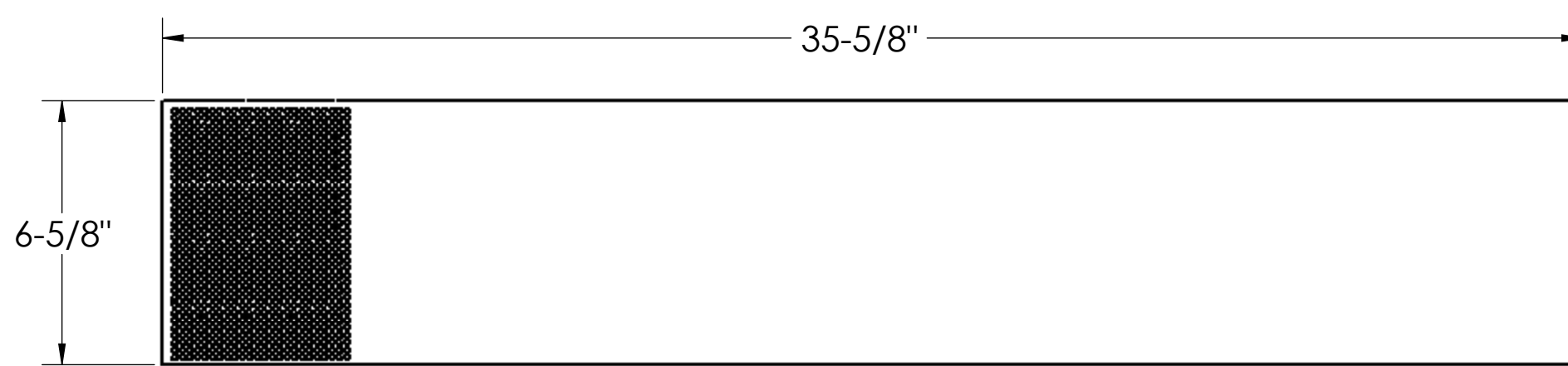
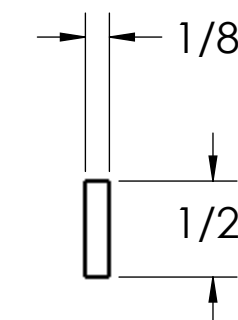

UNCOATED STEEL HARDWARE CLOTH  
#6 X .046" WIRE DIA

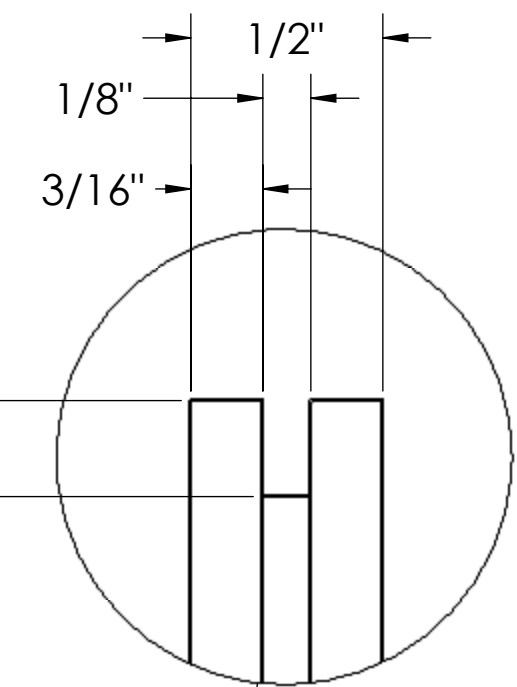
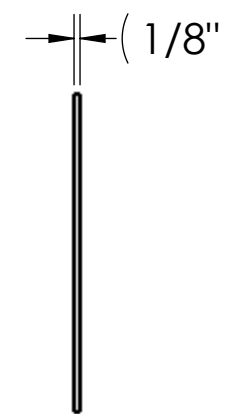

1/4"  
3X

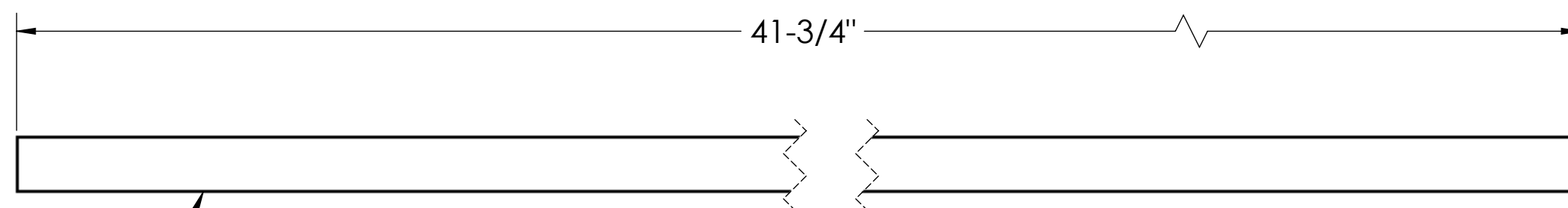

SIDE RAIL

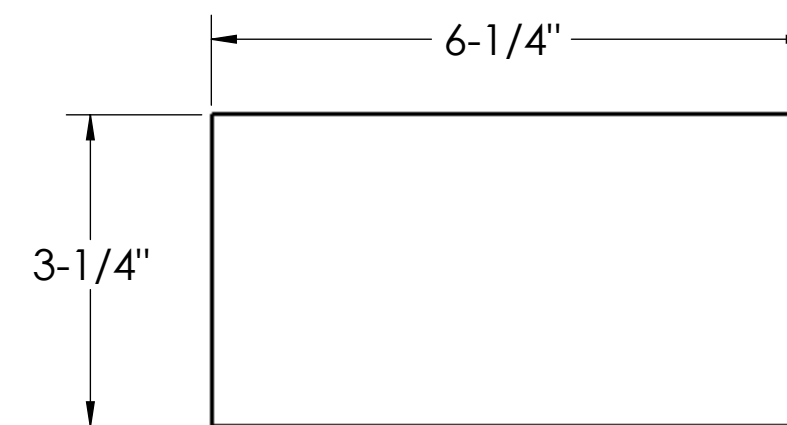

END PLATE

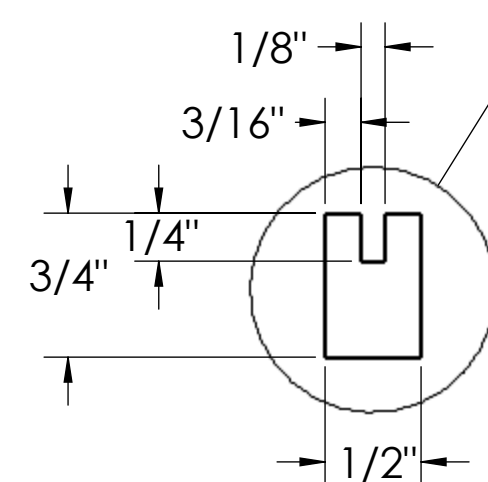

THE BEE'S KNEE'S APIARY

TITLE: TOP BAR BEE HIVE

UNLESS OTHERWISE SPECIFIED:  
DIMENSIONS ARE IN INCHES  
TOLERANCES:  
FRACTIONAL ± 1/16  
ANGULAR: MACH ± 1°  
TWO PLACE DECIMAL ± .03

AUTHOR: T.J. CARR  
MATERIAL: SEE B.O.M.S  
FINISH: SEE NOTES

DATE: 02/22/07  
DWG. NO. 001  
DO NOT TO SCALE  
REV X  
SHEET 6 OF 9

ITEM NO.	QTY.	StockSize
6	1	1/2" X 8" X 41-3/4" PLYWOOD
8	1	3/16" X 6" X 14-1/2" GLASS
10	1	1/2" X 1-1/2" X 5-1/2" PINE
12	1	1" X 1-1/2" X 32" (BOTTOM RAIL DROP)
19	1	1" X 1-1/2" X 7-1/2" (BOTTOM RAIL DROP)
20	1	1" X 1-1/2" X 32" (BOTTOM RAIL DROP)

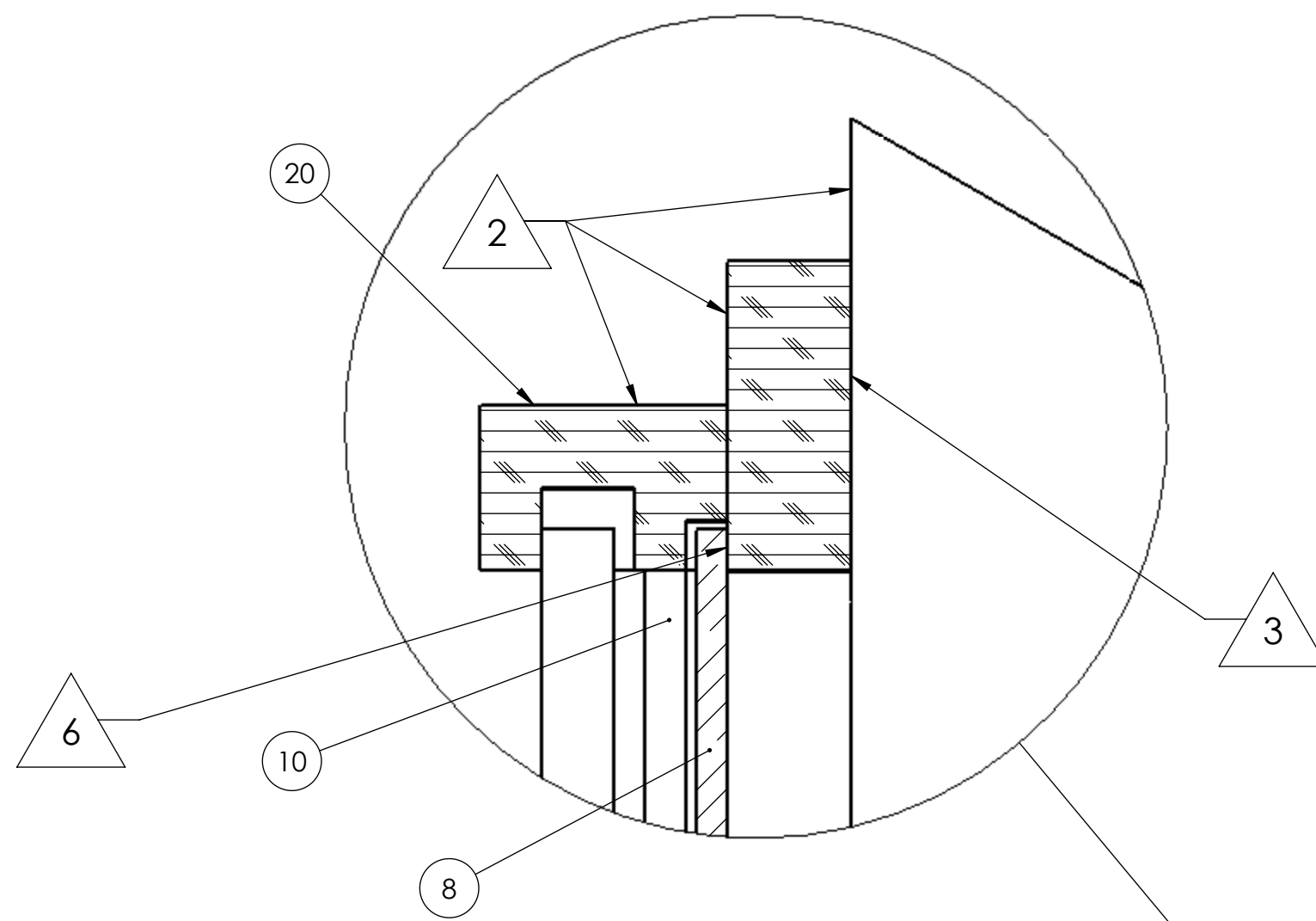
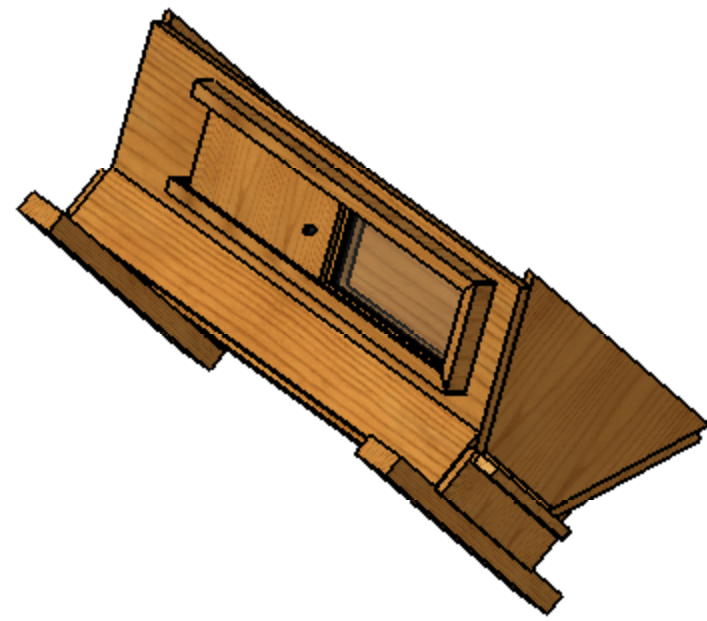

- 1. ADJUST END PLATE DIMENSION TO ALLOW A 3/8 GAP ABOVE LANDING BOARD.
- 2. PAINT ALL EXTERIOR SURFACES WITH WHITE OIL BASE EXTERIOR ENAMEL.
- 3. INTERIOR LIVING SPACE SURFACES NATURAL WOOD FINISH.
- 6. SEAL GLASS WITH CAULKING COMPOUND.

**PROPRIETARY AND CONFIDENTIAL**  
 THE INFORMATION CONTAINED IN THIS DRAWING IS THE SOLE PROPERTY OF <INSERT COMPANY NAME HERE>. ANY REPRODUCTION IN PART OR AS A WHOLE WITHOUT THE WRITTEN PERMISSION OF <INSERT COMPANY NAME HERE> IS PROHIBITED.

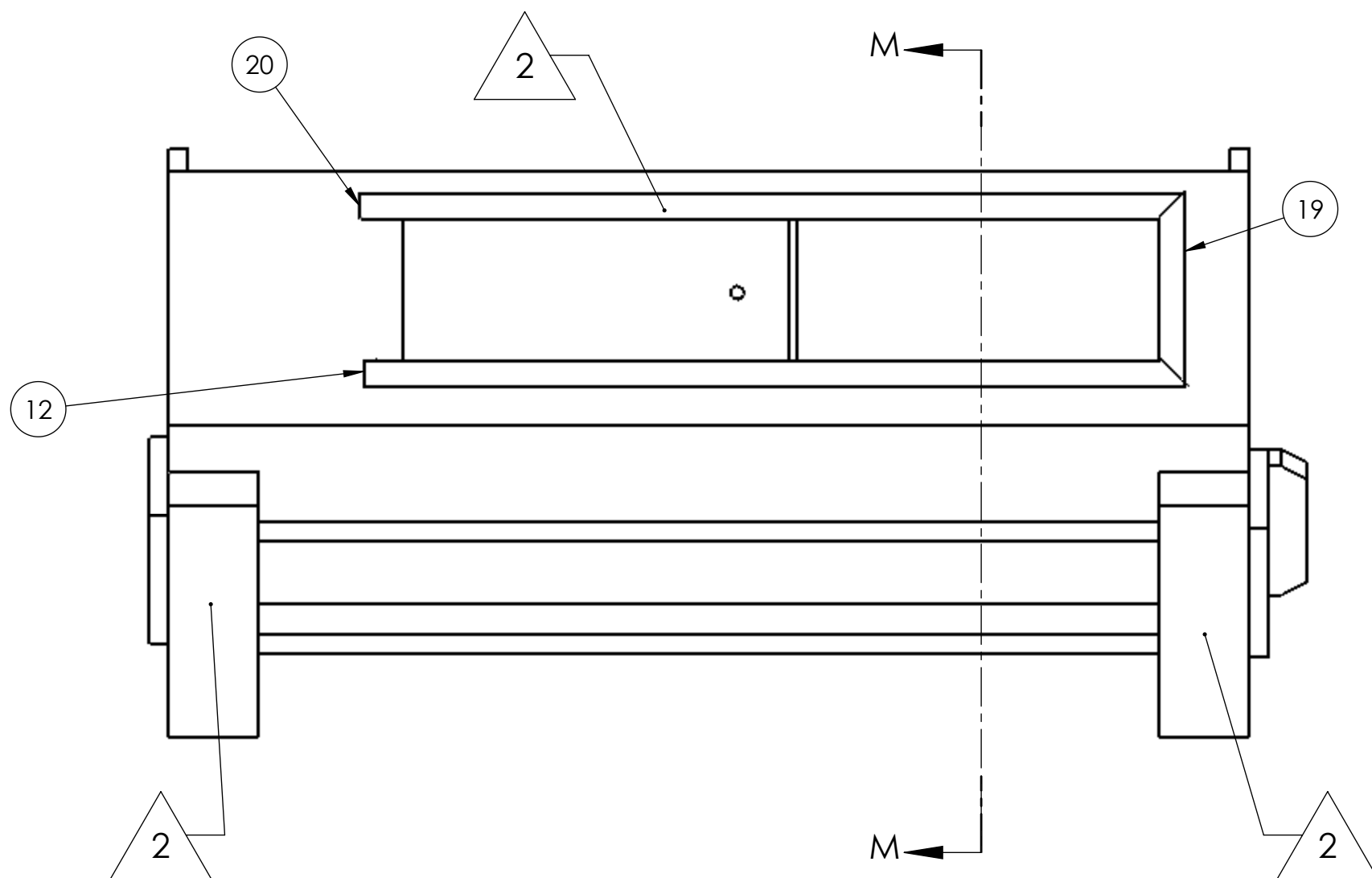

WINDOW AND DOOR ASSEMBLIES

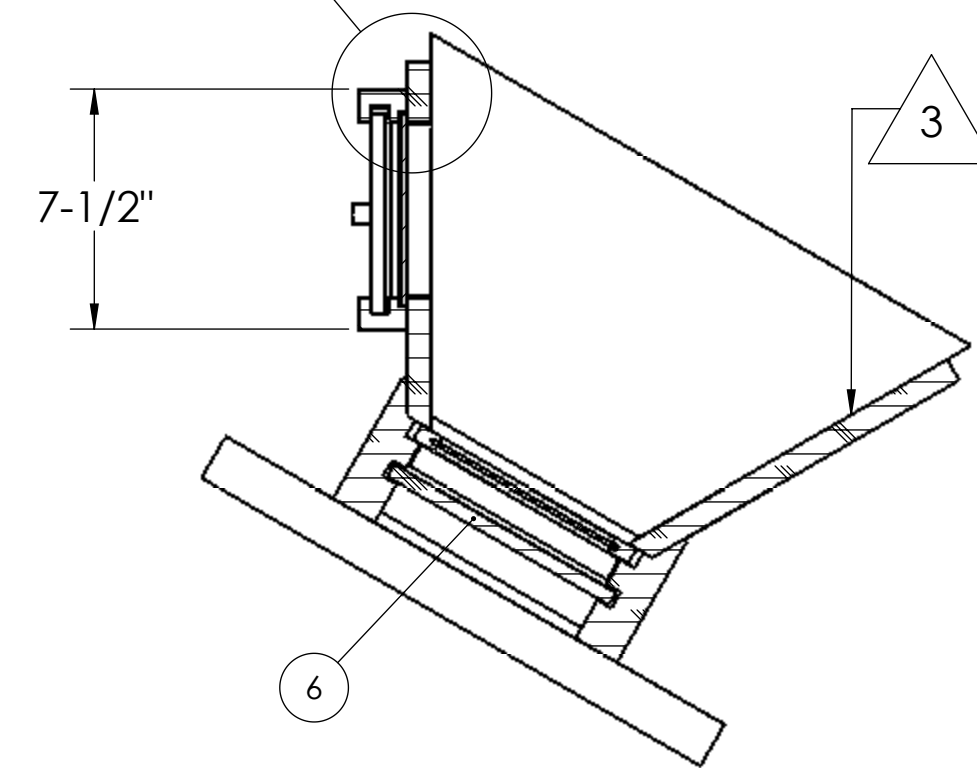

SECTION M-M

**THE BEE'S KNEE'S APIARY**

TITLE: TOP BAR BEE HIVE

UNLESS OTHERWISE SPECIFIED:		DATE: 02/22/07	
DIMENSIONS ARE IN INCHES	AUTHOR: T.J. CARR	DWG. NO. 001	REV X
TOLERANCES: FRACTIONAL: ± 1/16 ANGULAR: MACH ± 1° TWO PLACE DECIMAL ± .03	MATERIAL: SEE B.O.M.S	DO NOT TO SCALE	SHEET 7 OF 9
FINISH: SEE NOTES			

PROPRIETARY AND CONFIDENTIAL  
 THE INFORMATION CONTAINED IN THIS DRAWING IS THE SOLE PROPERTY OF  
 <INSERT COMPANY NAME HERE>. ANY REPRODUCTION IN PART OR AS A WHOLE WITHOUT THE WRITTEN PERMISSION OF <INSERT COMPANY NAME HERE> IS PROHIBITED.

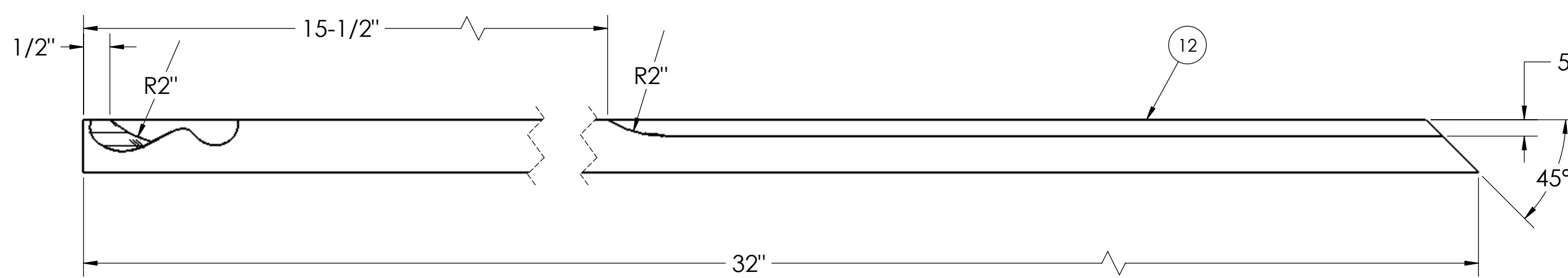

DOOR FRAME UPPER

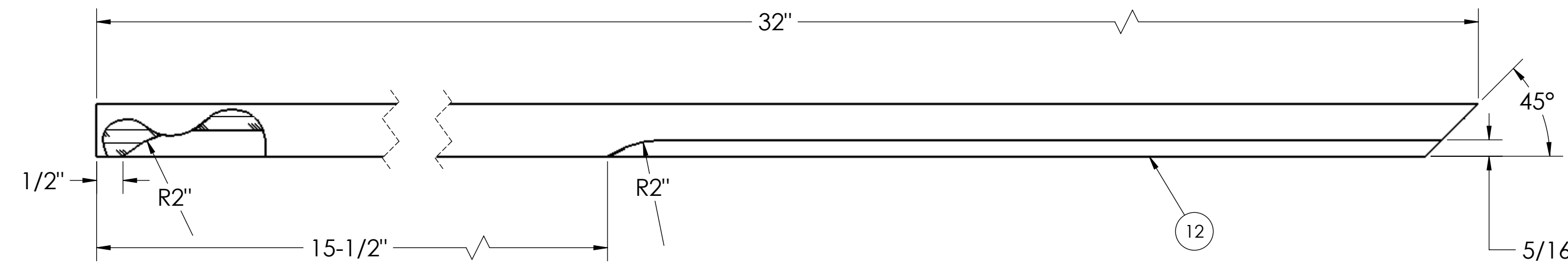
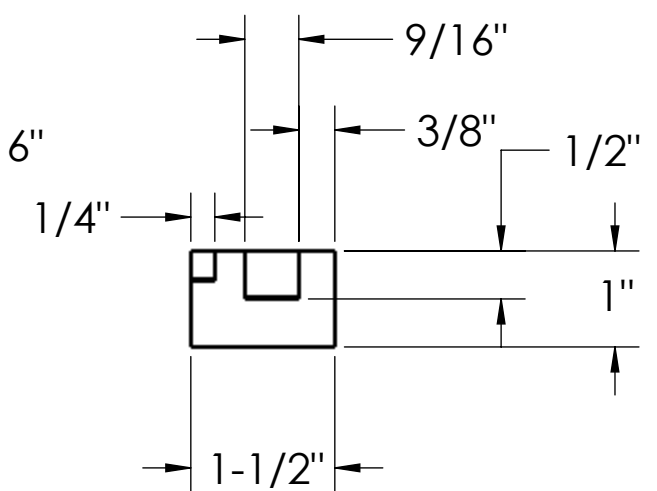

DOOR FRAME LOWER

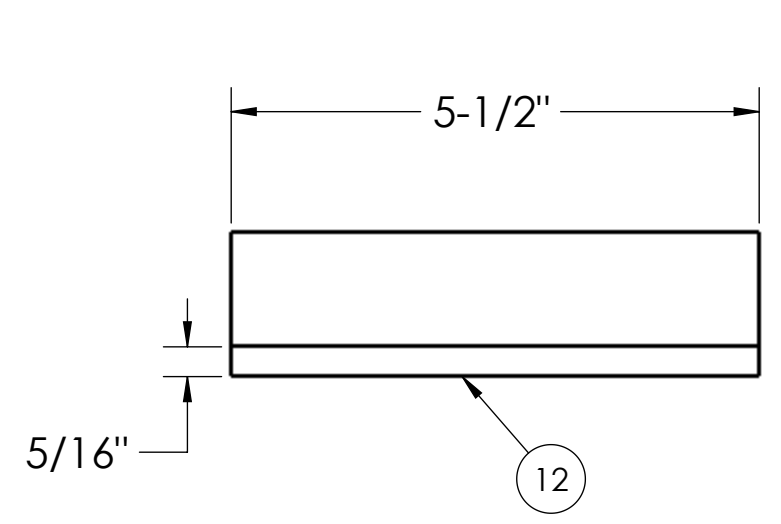
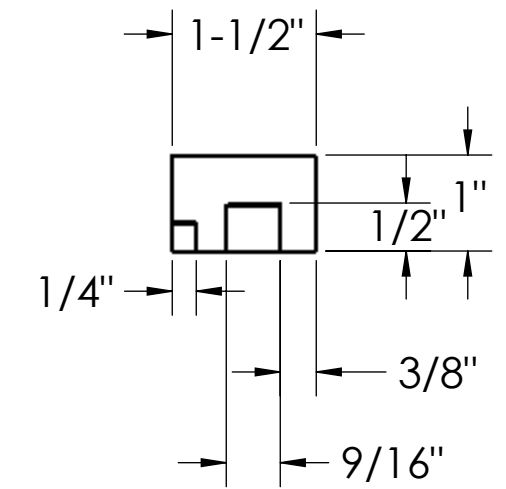

WINDOW GLASS RETAINER

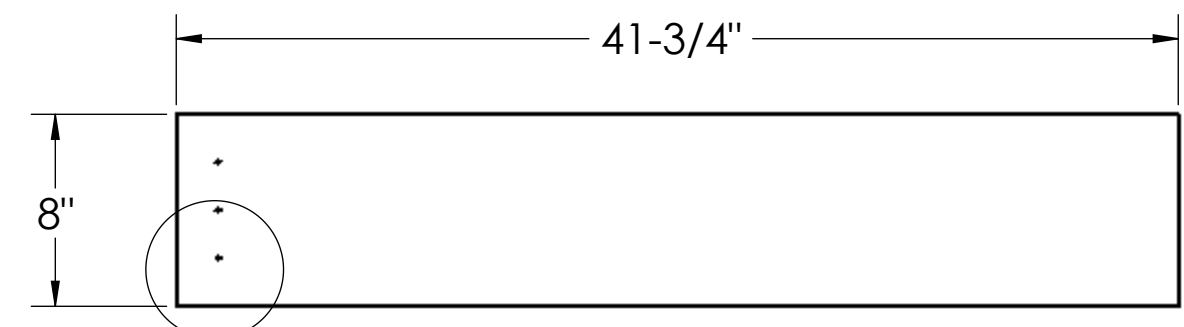
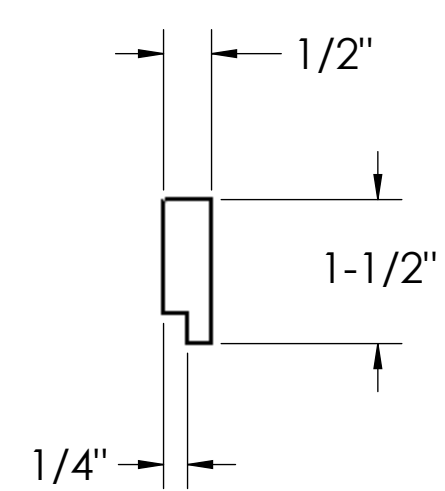

BOTTOM BOARD

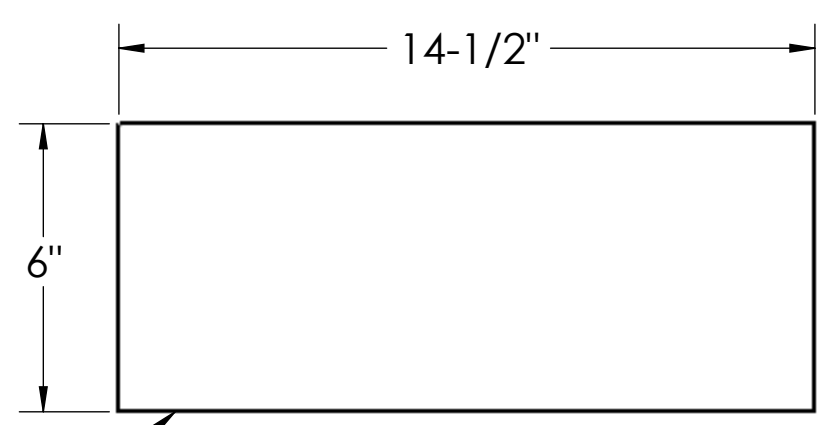
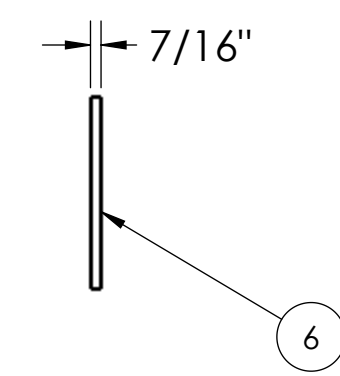

WINDOW GLASS

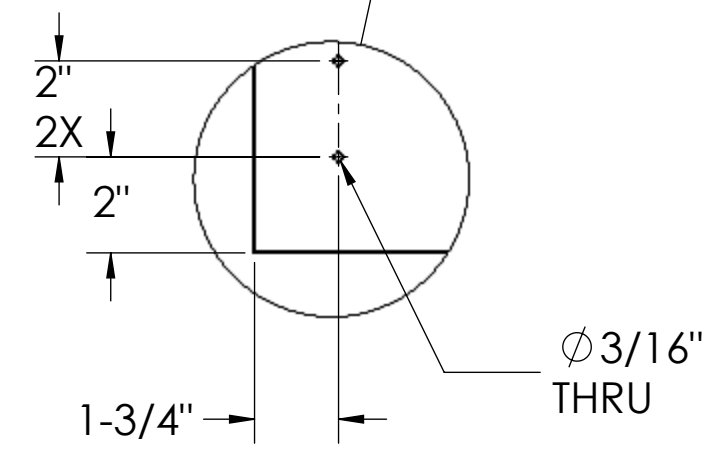
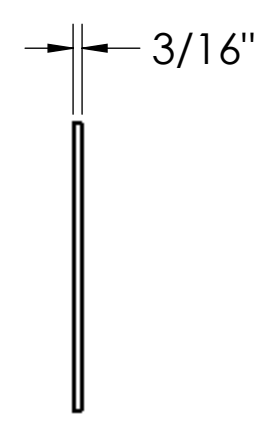

Ø3/16" THRU

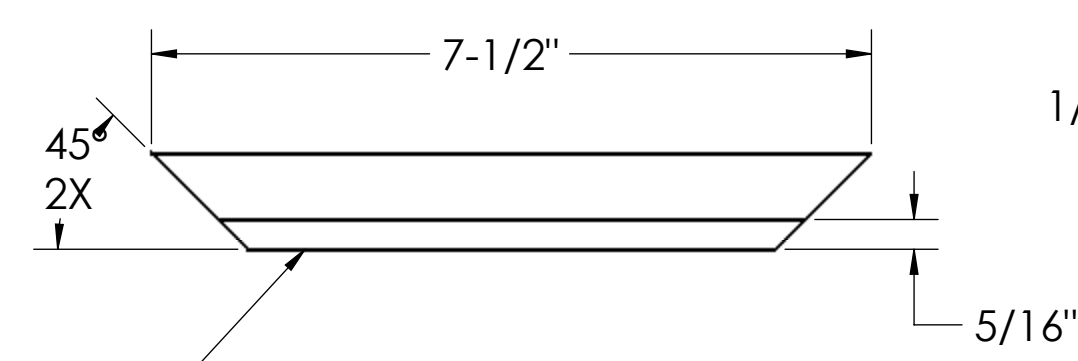

DOOR FRAME END

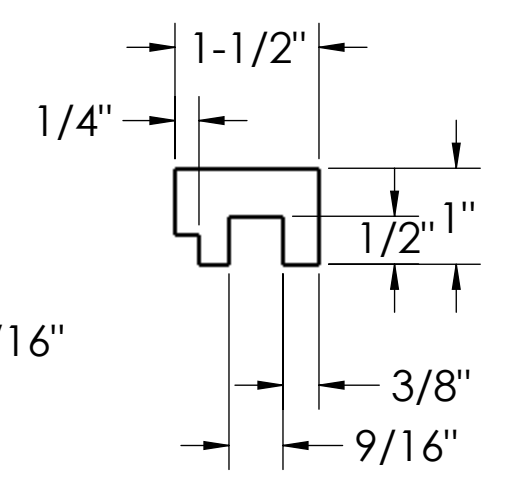

**THE BEE'S KNEE'S APIARY**

TITLE: TOP BAR BEE HIVE

UNLESS OTHERWISE SPECIFIED:		DATE: 02/22/07	
DIMENSIONS ARE IN INCHES	AUTHOR: T.J. CARR	DWG. NO. 001	REV X
TOLERANCES:	MATERIAL: SEE B.O.M.S	DO NOT TO SCALE	SHEET 8 OF 9
FRACTIONAL ± 1/16	FINISH: SEE NOTES		
ANGULAR: MACH ± 1°			
TWO PLACE DECIMAL ± .03			



ITEM NO.	QTY.	StockSize
1	1	1" X 2" X 19-1/2" PINE
2	1	1/4" X 3/4" X 17-1/4" PINE

7. COAT RIB WITH BEESWAX.

PROPRIETARY AND CONFIDENTIAL  
 THE INFORMATION CONTAINED IN THIS DRAWING IS THE SOLE PROPERTY OF <INSERT COMPANY NAME HERE>. ANY REPRODUCTION IN PART OR AS A WHOLE WITHOUT THE WRITTEN PERMISSION OF <INSERT COMPANY NAME HERE> IS PROHIBITED.

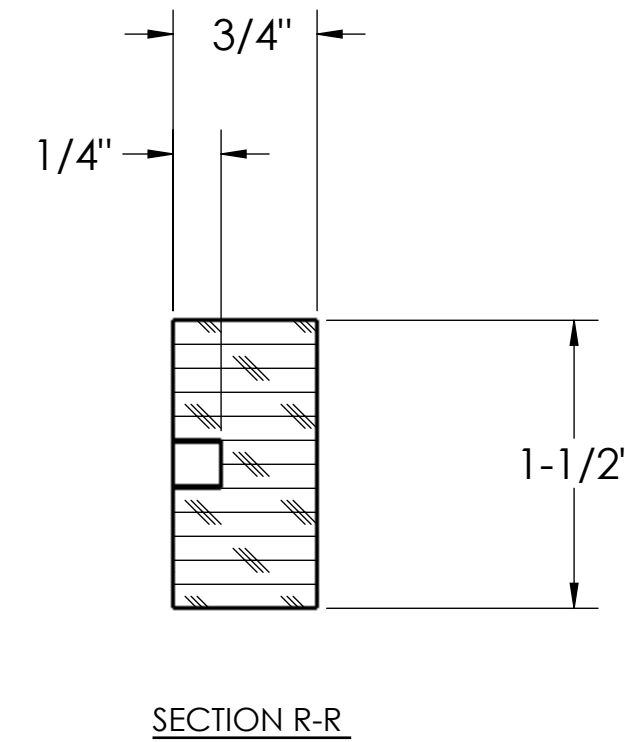
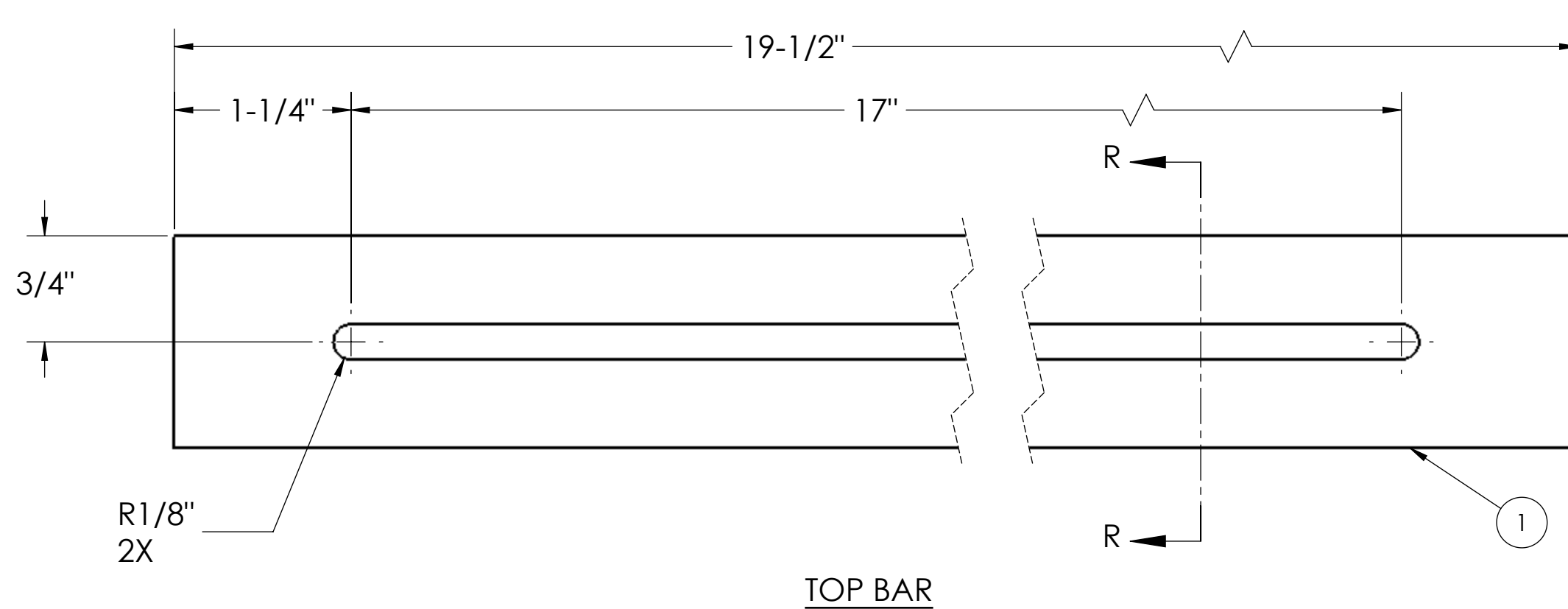
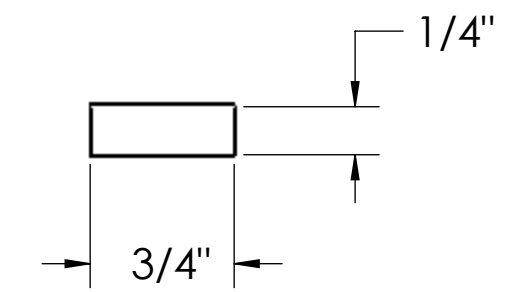
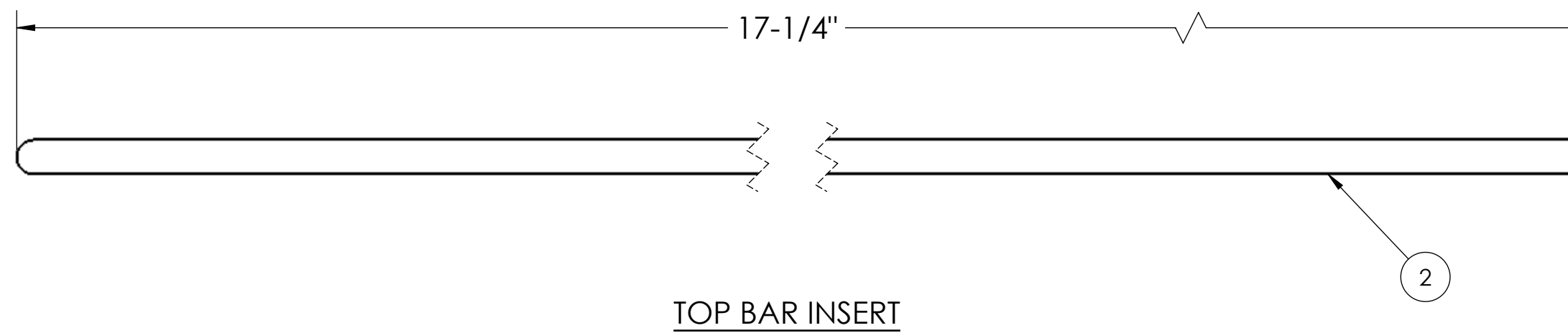
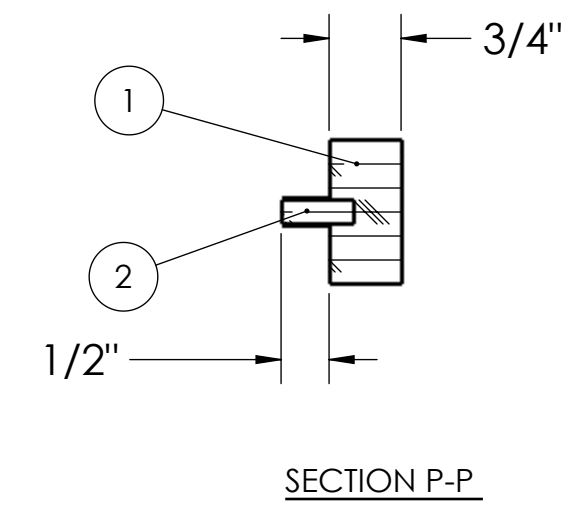
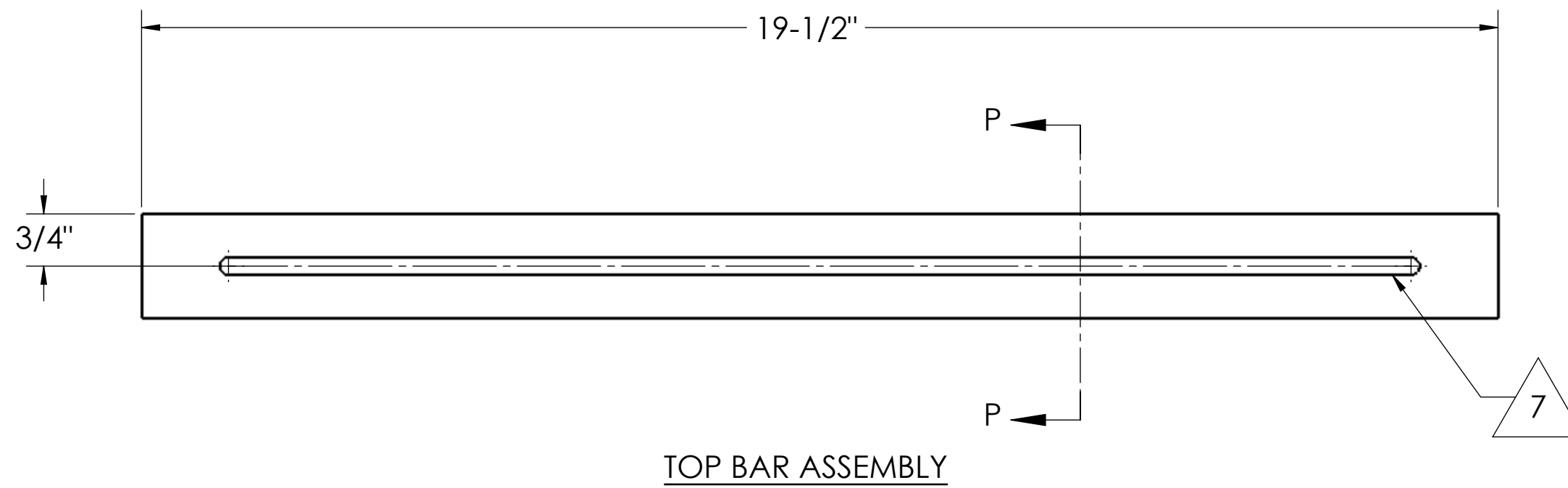
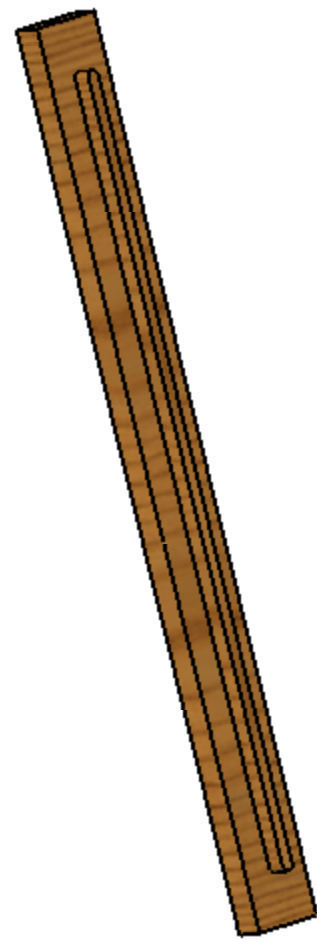

**THE BEE'S KNEE'S APIARY**

TITLE: TOP BAR BEE HIVE

UNLESS OTHERWISE SPECIFIED:		AUTHOR: T.J. CARR		DATE: 02/22/07	
DIMENSIONS ARE IN INCHES		MATERIAL: SEE B.O.M.S		DWG. NO. 001	
TOLERANCES:		FINISH: SEE NOTES		REV X	
FRACTIONAL: ± 1/16				DO NOT TO SCALE	
ANGULAR: MACH ± 1°				SHEET 9 OF 9	
TWO PLACE DECIMAL ± .03					