



CHOOSING TRANSITIONAL HOUSE PLANS FOR HAZARDOUS AREAS

EARTHBAG HOW-TOS

Patti Stouter, Owen Geiger
and Kelly Hart

Earthbag is an inexpensive building method that can work well with limited resources. This guide explains how to choose simple plans using locally available materials that can fit the culture and still resist hazards well.



Copyright 2010 Patti Stouter and www.earthbagbuilding.com

This work can be used according to the following

Creative Commons License: Attribution Non-commercial 3.0

TABLE OF CONTENTS

Transitional Housing	3
Build with Bags	4
Rebuild the Culture	6
Plan for Hazards	9
Cheap but Strong	10
Safe Earthbag Buildings	12
House Shapes:	
Clean Corners	15
Curving	19
Domes	21
Overlapping Corners	22
Compact & Symmetrical	24
Roof Shapes	26
Choosing House Plans	29
Costs	30
Details & Advice	31
Additional Information	33
Acknowledgements	33
About the Authors	34
Image Credits & Notes	35

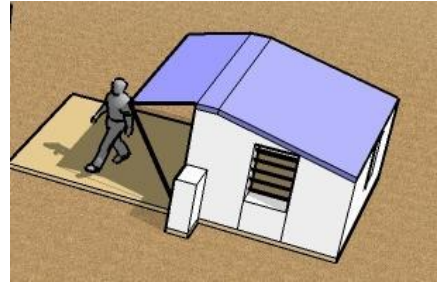

Transitional Housing

After a disaster people want to rebuild their homes. But they may immediately need a place to live.

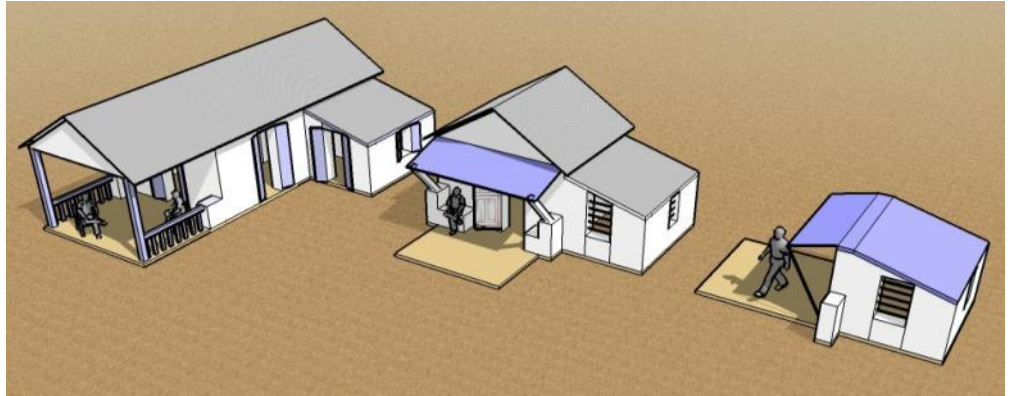

A transitional house starts with a single small room. It may have lower ceilings or temporary roofing. But with strong building techniques and additions in the future it can be a new start for a family. It can preserve property rights to land, begin to heal a community, and also grow into an adequate and safe home.

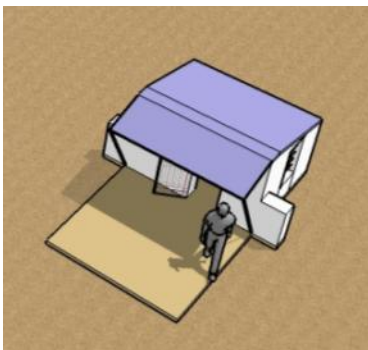

ABOVE: HAITIAN KAY
BELOW & LEFT:
CARIBBEAN CREOLE
STYLE

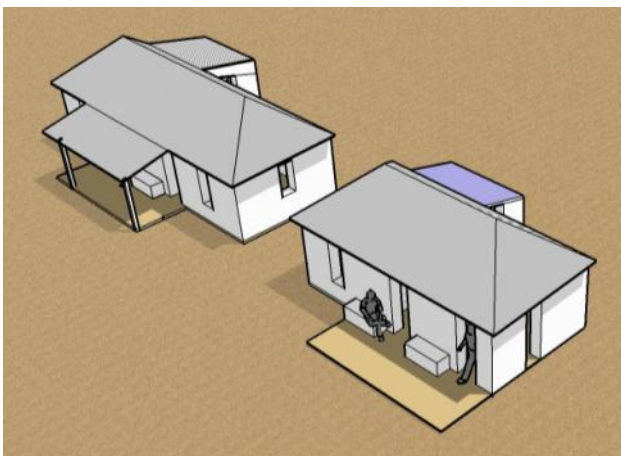

HAITI'S NEED: MARCH 2010

Wood is in desperately short supply even for cooking. Haiti's long rainy season makes traditional adobe construction awkward.

Haitians now prefer concrete to traditional wood and thatch and wattle.

Most of those who build in Haiti don't use engineering assistance. They are unselfish people, and find it hard to hoard so much precious cement and steel for their own buildings. This means concrete buildings are typically not built as designed.



Build with Bags

Many rebuilding after disaster have little to use. Often jobs are disrupted and extra people join together seeking shelter. There may be more hands to help than materials to use for a building.

Most places have earth that can be used for building. Although many traditional earth building methods take a lot of time, there is one simple new method that is quicker and can withstand rainy climates.

RIGHT AND ABOVE: BUILDING WITH EARTH BAGS

Adobe blocks must dry well before building. Compressed earth blocks (CEBs), like adobe, must be built by skilled masons, and need to be contained for earthquake safety by mesh and plaster or other materials. Cob buildings can only be built a few feet in height at a time, and take longer to dry than adobe. Rammed earth can only be built with relatively expensive forms where wood is in short supply.

With some light and locally available materials, there is a simple way for unskilled people to make very strong buildings out of earth. Earthbags are grain or animal feed bags of

polypropylene that do not biodegrade. These can be filled with earth and stacked like big bricks with barbed wire between courses.

LEFT: FILLING BAGS

A layer of earth plaster protects the bags from the sun. Because the bags and wire add a lot of strength to the building, more kinds of soil can be used for earthbag buildings than for any other type of earth construction.



THE SUN HOUSE



This house built at an orphanage near Les Cayes, Haiti for Pwoj Espwa was undamaged by the earthquakes. Earthbag is now being considered and tried by Haitian residents, mission agencies, and aid organizations.

Earthbag is an ideal material for houses that grow because buildings can be completed using only hand tools. It takes a lot of work, but many people have customs of helping each other. Since it is cheap and can use scavenged materials, once someone learns how to build, they will be able to add on soon.

Walls can be made strong enough to resist earthquakes, hurricanes, and an occasional flood by using proportions that also look strong. The right shapes and wall heights can be learned as simple rules of thumb. For reinforcing earthbag uses inexpensive materials like fishnet, scrap wood or pipe, corrugated metal, twine or rope, strapping,

bamboo, or thin rebar. In most of the world these are much cheaper than reinforced concrete.

Earthbag can also be shaped to look like traditional buildings. Earthbag walls don't require the distinctive buttresses of adobe, or the ultra-thick walls of cob construction.

RIGHT: INTERIOR OF AN EARTH BAG HOUSE

Walls built of earthbags can be finished to look much like cement or CEB walls if there is some metal available for corner reinforcement. Finished walls are about 16-18" wide when plastered.



Buildings built with earthbag overheat less in hot climates than concrete because they have less thermal mass. If built without cement they are also less sweaty in humid climates, and balance humidity levels.

Earthbag is a type of geo-textile construction that is able to flex somewhat during earthquakes and is strong enough to resist hurricane force winds. But like the adobe block walls they resemble, the shapes of earthbag houses should be chosen carefully because the shape influences the wall strength and the type of reinforcement needed.

Rebuild the Culture

House shapes should be those already common to an area as much as possible because they are adapted to the lifestyle and filled with meaning.

RIGHT: CREOLE STYLE HOUSES IN NORTHERN HAITI



In most of the world small houses are used for storage and shelter during storms, but most of life happens in the courtyard or yard.

In hot climates people spend most of their time outside. Many or large doors open to let breezes through. They are located to avoid overheating in the afternoon sun. Spaces defined by porch roofs or the shade of nearby trees are a part of the home.

In warm and temperate climates many people who live in small houses also spend a lot of time outside. Entrances and walled courtyards often face east to catch the morning sun. Outdoor areas are sheltered from breezes.

In addition to traditional ways of laying out yards, every community has building shapes that are familiar. Roof lines in the past angled precisely to make the traditional materials work well in the climate. Buildings faced certain directions to catch or escape the sun or winds. Despite recent changes from new materials or different family sizes, each culture has basic building shapes that 'feel right.'



ABOVE: AN UNPLASTERED HAITIAN KAY

People recovering from disasters don't want someone else's vision of a better place. They want to resume their own lives. They want their houses and yards to fit how they live. And they want to see building shapes that symbolize their history and traditions.

Basic house shapes determine whether buildings are wide or narrow, tall or single story. What shapes are the roofs? Does a porch or balcony stick out? Is the front entry in the side or the end?

Each community may have several types, and each type several variations. For the people of the community these shapes may be important symbols of their history or beliefs or class or ethnic identity.

THE HAITIAN LIFESTYLE:

The shaded 'galerie' porch faces the entrance path or road of most houses in low-lying Haiti. It serves as a breezy living room and is the setting for greeting and talking with neighbors.



On country hillsides, several small houses share a simple family compound. The entrance and porch still face the path, but one enters when passing through the hedge. People work and tend animals in the yard.

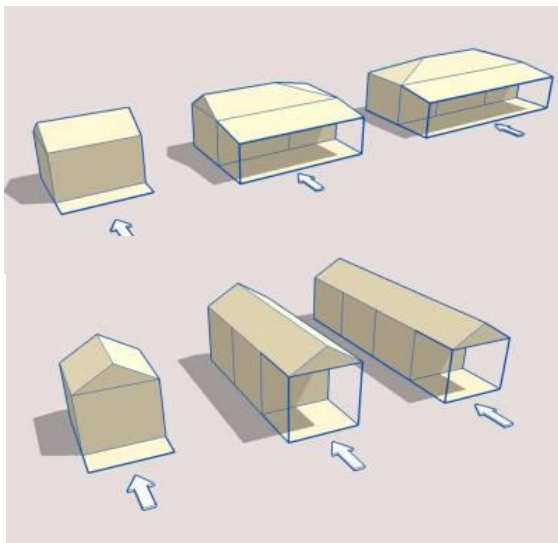

LEFT: WIDE OR LONG AND NARROW HOUSE SHAPES

BELOW: 2 STORY TOWNHOUSES IN NARROW SHAPES

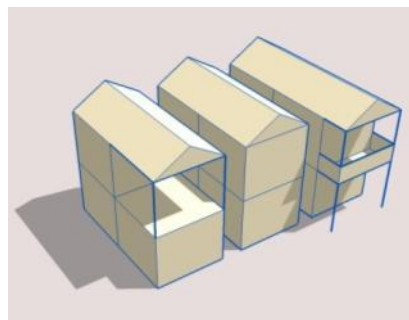

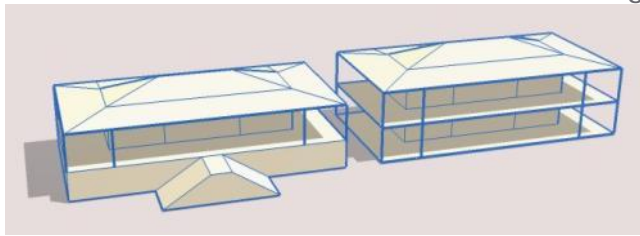

LEFT: 2 STORY WIDE SHAPES

BELOW: HIP ROOF ON AN OVAL BUILDING

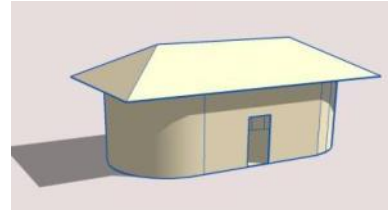
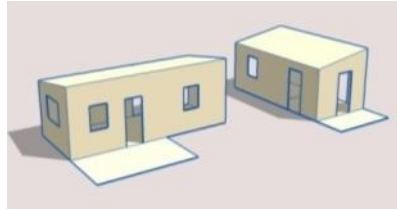
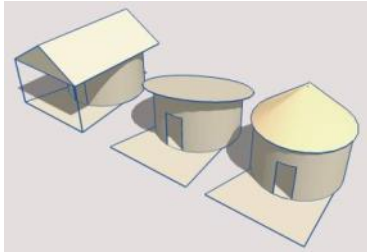

ABOVE: ROUND BUILDINGS, SHED ROOFS

Just changing building proportions or roof types can give very different messages to the community. Make sure everyone has seen how the buildings will look.

Disaster rebuilding is not the time for innovations, unless the people who will live in the house are asking for changes. It is too easy to 'improve' a house so that it does not work in either the climate or the social environment.

Simple shapes and a simple construction process will allow people to use their own styles. Decoration is important in many cultures. They will elaborate and make buildings their own if given a chance.

RIGHT: A TRADITIONAL HAITIAN KAY

BELOW: DECORATED EARTHEN PLASTER ON AN EARTHBAG BUILDING



Plan for Hazards

Any construction in a disaster area should be able to weather all the region's hazards.

Buildings cannot be made strong enough to survive direct tsunami waves. In these coastal areas homes need to be relocated to higher ground. At moderate heights above sea level some precautions can be taken to shape buildings to resist some waves. The recommendations for earthquake reinforcement will help, but seek special advice about shapes that can withstand waves.¹

For hurricanes, wall reinforcement and attachments that anchor roofs to heavy walls or footings are important. Smaller roof overhangs may help. Open structures can be built strongly but flexibly or located on the side of the building more sheltered from storm winds. The first inhabitants in most areas built light houses that could easily be rebuilt. Later generations built sturdy houses on the hillsides that were usually more sheltered from storms.

Haiti's Hazards:
High earthquake risk
Long rainy season
Hurricanes



Strong walls, cement stabilized wall bases, and raised floors can preserve buildings through occasional floods. For high flooding, supports can raise house interiors above the flood level.

There are different ways to make buildings survive earthquakes well. They can be made stiffer or more flexible. Some experts recommend that houses built on solid bedrock should be lighter and flexible, while buildings on softer sandy soil should be more massive and stiff. The shape of a building is also very important to allow it to survive an earthquake.

Earthbag walls are heavy enough to hold down the roof and strong enough to resist storm winds. They are strong enough to resist repeated floods as long as any portions of walls exposed to water are cement stabilized or use gravel-filled earthbags. Their flexibility makes them a good candidate for surviving earthquakes without major damage.

Since earthbag building has different techniques for increasing strength, houses that need reinforcement can be cheaper if the shape is chosen to use the materials that are inexpensive or more easily available.

Cheap But Strong

Before you decide on the details of a house's plan, find out which of these materials can be scavenged from debris or purchased reasonably in your area:

Metals:

½" (12 mm) diameter rebar, 2- 5' (60 cm- 1m) lengths

4' (120 cm) or longer pieces of metal pipe

1-1/2" x 4" (4-10 cm), or other size, hollow rectangular section steel tubing

8- 12" (20- 30cm) wide strips of corrugated metal roofing at least 4' (120 cm) long

Hurricane straps, door or shutter hinges, security doors, window frames, grillwork, nails, wire, plasterer's galvanized lath or galvanized chicken wire

Necessities:

50# poly bags 18 x 30" (46 x 76 cm) or tubes (larger bags will also work, but use more fill and labor)

4-point barbed wire (or possibly 2-point) -any gage works

6 mil plastic 30" (80 cm) wide to cover top of wall

Poly or nylon strapping and twine

Wood:

Roof framing of 2- 4" (5- 10 cm) diameter poles or 2x4s, 2x6s or 2x8s (5x 10, 15, or 20 cm) lumber

Plywood scraps 8- 12" (20- 30 cm) wide

Wood or wicker shutters

BELOW: WOOD DOOR FRAMES



Plastics:

Tarpaulins

Poly fishnet or plastic plasterer's mesh

Nylon or poly cord, baling twine

Plumbing pipes



Glass:

Bottles for light spots

Window glass, windows

ABOVE: BOTTLES IN WALLS LET IN LIGHT

Precast concrete or brick:

Vent blocks, chimney tiles

Cement

Natural materials:

Soil that includes some clay

Gravel

Vetiver thatch

Reeds and branches for wattle

BELOW: BAGS AND SOIL ARE THE MAIN INGREDIENTS



Safe Earthbag Buildings

The keys to safe earth buildings (including earthbag houses) are good quality construction, robust layout, and good seismic reinforcement.ⁱⁱ Earthbag walls are basically oversized adobe units with increased compressive strength from the tamping process and greater horizontal tensile strength from the matrix of bags and embedded barbed wire. Like adobe, in areas with high risk of earthquakes, extra reinforcement should be added to earthbag walls.



RIGHT: TAMPING AN EARTHBAG SCHOOL WALL IN SIERRA LEONE

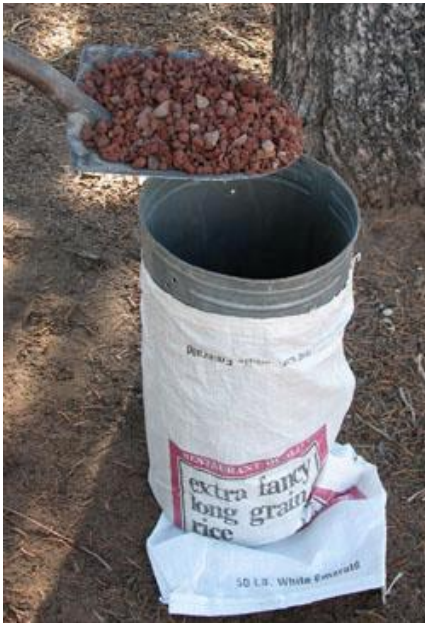

Good quality construction involves building walls plumb, using strong bags not exposed to the sun for more than a few weeks before covering, and starting with gravel foundation layers to resist dampness.

It also means using good building soils on good foundation soil. Soil can be looser than for adobe, but must not be too silty, have too much sticky clay, or be only sand. Do some simple tests to check if the soil is appropriate. See Appendix A for an ebooklet with simple directions.

LEFT: A BOTTOMLESS BUCKET FORM FOR BAG FILLING



BELOW LEFT: GOOD SOIL HAS A LITTLE CLAY

Robust layout means similar dimensional standards that work well in adobe walls. Adobe codes allow walls to be 10 times as high as their width.

Heights of 8- 9 times their width are a conservative standard for earthbag in seismic areas until further seismic testing can be completed. This would result in a 15" (38cm) wide earthbag wall of 10' – 11'-4" (3- 3.4 m) height. If a greater total wall height is required, the lowest portion can be built of larger 24" (60 cm) wide bags.

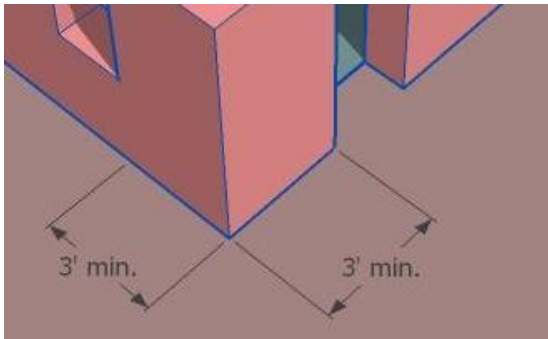

Walls must have at least 36-39" (1 m) from each opening to a corner. For 15" wide earthbag walls, windows must be at least 8'-6" (2.6 m) apart unless there is an intersecting wall, pier, or buttress between them.

An earth wall should have at least 9 square feet (1 m²) of surface area between openings. Adding piers or buttresses or intersecting walls between wall openings can allow them to be placed closer together.

Lintels above door or window openings are simple when integrated into the bond or ring beam. If separate from the bond beam, lintels should extend into the walls at least 16" (40 cm) each side of an opening.

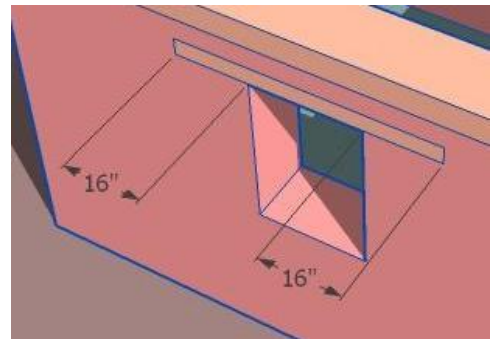

Window and door openings can also form arches without lintels. Arches require temporary formwork and must be completed with care.

Earthbags are reinforced in the same ways that have proven successful to protect adobe buildings.ⁱⁱⁱ The bases of walls, corners, and the tops of walls are the most important areas to strengthen.

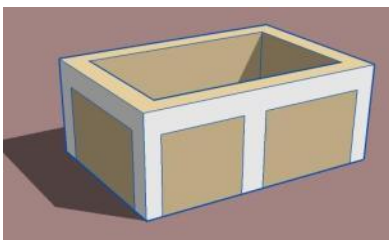

One successful type of adobe wall reinforcement involves cement plastered wire mesh forming an exterior upper ring and corners and intermittent columns. This involves inner and outer mesh tied together with twine or cord. Other strategies use vertical and horizontal ropes or rods of bamboo.

Buildings without concrete footings can have shallow rubble footings. In areas subject to earthquakes, it may also be important to tie the building together close above its base to avoid a need for a reinforced concrete foundation. Doubled barbed wire nailed into the first course of bags may accomplish this. A stronger base reinforcement could use strips of corrugated metal above the first bag layer, strapped and fastened similar to a metal bond beam.

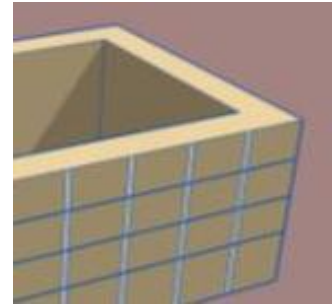

RIGHT: BARBED WIRE ADDS TENSILE STRENGTH

Since earthbag already has significant horizontal strength from barbed wire, it is most important to add vertical strength and to stiffen straight walls. Rebar or strapping or rope can be important in uniting earthbag buildings vertically. A well-integrated bond beam out of one of several different materials can be used to cap and stiffen the walls.



Some builders use mesh to adhere plaster more easily. Plastered mesh as a full exterior cladding can also add a significant amount of strength to unite walls and resist damage from earth tremors.

Adobe buildings covered with mesh survive more violent quakes without developing cracks than similar buildings without mesh. For smaller adobe block or CEB the mesh also serves to contain units that might be shaken loose in a severe quake and thus preserve the structure.

LEFT: MESH AND REBARS STRENGTHEN EARTHBAG

House Shapes: Clean Corners

The materials that have the most impact on the shape of earthbag structures are cement and steel.

Earthbag can resemble ordinary cement block buildings. Rebar or sections of pipe and metal lath at corners can allow simpler 'clean' corners without overlapping corners of piers or buttressing.

RIGHT: EARTHBAG DOESN'T NEED PIERS



BELOW: PLAN SHAPES THAT WORK WELL WITHOUT PIERS



Earthbag houses with clean corners use metal for added strength. Straight exterior walls longer than 9' (3 m) can be used if an interior wall intersects them every 9' (3 m).

Corners are subject to extra stress during an earthquake. Adjacent walls in rectangular buildings face different directions. Because earth tremors are directional, adjacent walls often receive different amounts and kinds of force during an earthquake. This is why buildings often are damaged at corners.

RIGHT: STANDARD REBAR CORNER REINFORCEMENT

Reinforcing at corners serves to unite and keep the two walls together. Rebar is an important part of most earthbag buildings, because it can easily be pounded through bags without reducing their strength. ½" (12mm) diameter rebar in 5' lengths can be pounded through each corner when the wall reaches 5' height and again near the top, as shown below.

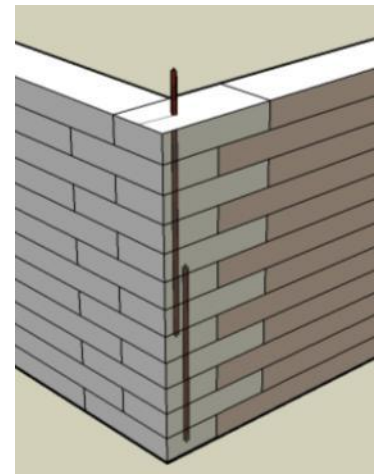

Door and window openings must be reinforced in the same way unless they are built around a strong metal or wood door or window frame.

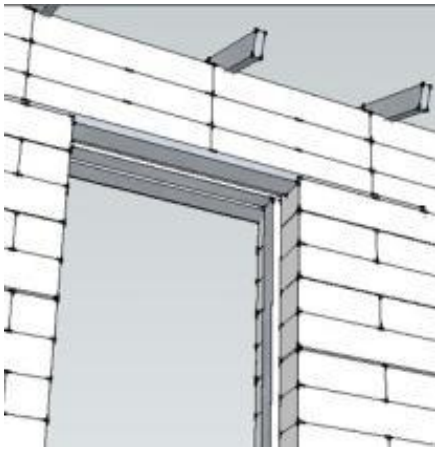

Pieces of steel angle, tubular steel, or bamboo could replace the rebar at the corners. One of these materials would be used vertically inside each corner and fastened securely at every other course to metal or plastic lath on the outside of the corner, with either galvanized wire or strong poly or nylon cord.

BELOW RIGHT: ALTERNATE INTERIOR CORNER REINFORCING

ABOVE: METAL DOOR FRAME IN AN EARTHBAG WALL

Bamboo is quite strong for reinforcing cement or adobe or earthbag. If encased in dry earth neither wood, bamboo, or metal will rot or rust. 'Raw' earth (not mixed with cement or bitumen) is a material that maintains a steady maximum moisture content of 0.4- 6%. It can moderate interior humidity in contrast to cement which attracts water and becomes sweaty in humid conditions. Insects cannot live in an earth wall because they need 14-18% humidity, and fungus needs 20% humidity. In a dry location (under a roof that doesn't leak) earth will preserve materials which are encased in it.^{iv}

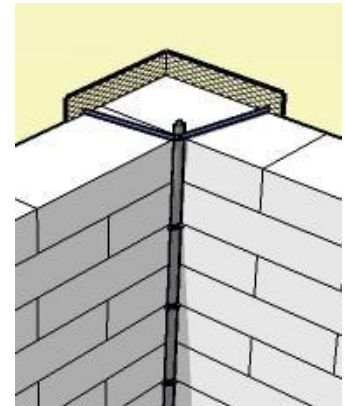

But there is some risk of termite damage with natural materials only lightly encased in earth. Insects including termites do not live in pure earth walls. But termites are very persistent and in hot regions may be able to tunnel through shallow earth coverings or through earth floors to the interior seeking plant materials to consume. Bamboo (or wood for reinforcement) if used should be either well protected against termites by being covered with earthen plaster that contains borax or something to deter termites, or by being left exposed so that it can be monitored and replaced.



LEFT: REINFORCED CONCRETE BOND BEAM

The other most important use of metal in an earthbag building is for the bond beam. Any structure in a hazardous area needs a bond beam of reinforced cement, wood, tubular steel, or

corrugated metal. A standard reinforced concrete bond beam is the strongest option if cost allows.

A cement bond beam is formed with scrap wood on top of the earthbag wall, 6" (15 cm) high. It uses at least 2 continuous pieces of ½" minimum diameter rebar.

Rafters can be attached to the wood forms if they are not removed. Or rafters can be attached to a wood top plate above the bond beam, or fastened to angle brackets embedded in the concrete.

Heavy wood beams or single or doubled poles can replace concrete for a bond beam in areas not too subject to termites and wood rot.

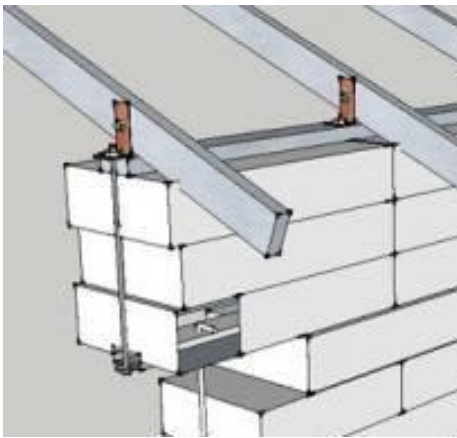

Tubular steel can be used also, if threaded rods 18" long are available to sandwich 3 layers of bags securely between either 2 pieces of steel or steel and a wood top plate. The steel will have to be bolted together at corners securely.

LEFT: TUBULAR STEEL BOND BEAM

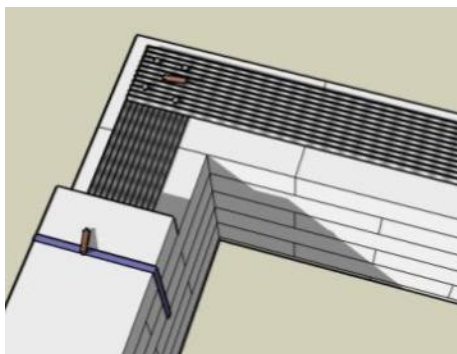

Corrugated metal may make the cheapest bond beam. Strips 8- 12" (20- 30 cm) wide are laid 2 courses below the top of the wall and fastened with galvanized metal mesh and/ or galvanized wire or strong cord to a wood 2x4 (5 x 10 cm) top plate above the top bag layer. Nails pounded into the bag below can tie the strips together at the corner. Since the corrugated metal provides the stiffening, the 2x4 top plate can be assembled from shorter scrap pieces.

ABOVE: CORRUGATED METAL BOND BEAM

MATERIAL COMPARISON: CLEAN RECTANGULAR CORNERS

A basic room size for the first part of a transitional house might be 108 square feet inside or 9' x 12' (108 m² or 2.7 x 3.4 m). See the information below to understand how much reinforcing metal will be needed for a 9' (2.7 m) high vertical walled building. These figures assume one 30" (75 cm) wide door and three 24"x 48" (60 x 120 cm) window openings.

The total rebar needed is given as a range. The lower figure assumes the use of a tubular steel pipe or corrugated metal bond beam, strong door and window frames of wood or steel, and interior vertical reinforcement to strengthen the corners.

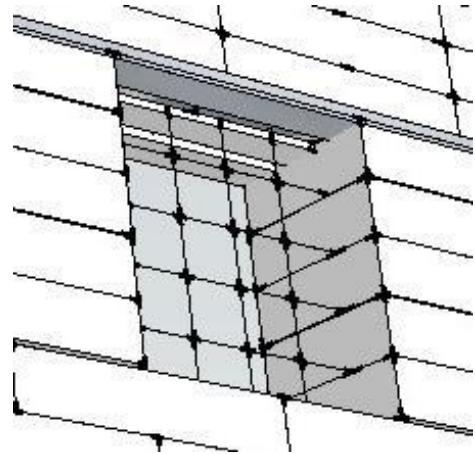

RIGHT: DOUBLED REBAR WINDOW GRILL

The higher figure assumes a simpler construction using more rebar. The window and door openings will not have frames, but rely on vertical rebar to strengthen them. (Openings can be covered with tarps for quick construction as a shelter). A single directional grill of rebar 10" apart can extend 12" (30 cm) into the walls on each side to provide some security. The rebar needed to reinforce a concrete bond beam is also included.

REBAR NEEDED FOR A SINGLE RECTANGULAR ROOM WITH CLEAN CORNERS

108 SF / 10 M² INTERIOR AREA

Optional rebar for corners: 40' (12 m)

Opt. rebar for windows & door: 94' (29 m)

Rebar tying bond beam to wall: 48' (15 m)

Rebar for concrete bond beam: 90' (27 m)

Total rebar needed: 48'- 270' (15- 83 m)

House Shapes: Curving

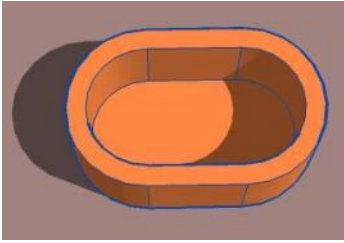

Earthbag walls are much stronger if they curve in a radius between 3' (1m) and 15' (4.5 m). In addition to perfect circles, shapes that include circles can be used.

LEFT AND BELOW: BUILDING PLANS WITH SOME CURVES

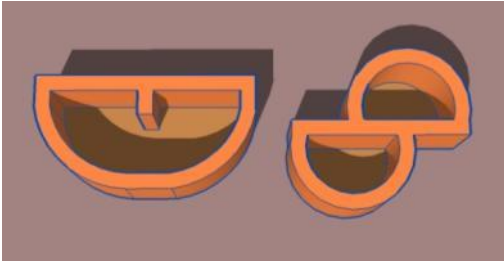

Rooms with curving walls appear larger from the inside. But furniture like beds and dressers may be difficult to fit in, and adjacent rooms must be planned carefully.

RIGHT: ROUND ROOMS FOR A DORM IN NEPAL

Concrete bond beams can fit on these curving walls if flexible wood or plastic is available for forms. But on strong curving walls an alternative lighter bond beam may be enough. If the building contains straight walls it must be interconnected to the more traditional bond beams on the straight sections of walls.



In areas where cement is very expensive a bond beam of 2 layers of tubular bags can be used on curving walls filled with stabilized earth. This would need a double ring of rebar, and a double ring of heavier gage barbed wire.

LEFT: CURVED REINFORCED CONCRETE BOND BEAM

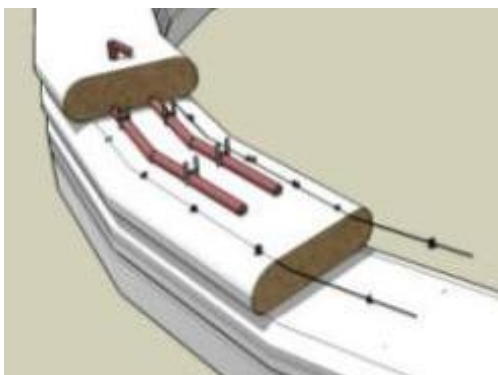

BELOW LEFT: TUBE BOND BEAM OF STABILIZED EARTH

Tubular bags are a little more difficult to work with. They must be filled in place and require construction teams to pass soil to the bag fillers. Stabilized earth

contains between 6 and 15% Portland cement, depending on the type of soil available.

The structural benefits of rounded buildings can be gained in subtle ways. Curving walls under a traditional shaped roof do not appear very different from common buildings. Curved shapes also use fewer bags than rectangles and are simpler to build.



RIGHT: SLIGHTLY CURVING WALLS IN COSTA RICA



Even slightly bowed walls with corner buttresses have similar strength to circles.^v If few reinforcing materials are available, there are still many ways to build earthbag.

RIGHT: A BOWED WALL SHAPE

MATERIAL COMPARISON: CURVING WALLS

This comparison room assumes a vertical wall oval building shape 10' x 13' (3 x 4 m) that has 108 square feet (10 m²) inside.

REBAR NEEDED FOR A SINGLE OVAL ROOM WITHOUT CORNERS

108 SF / 10 M² INTERIOR AREA

No rebar needed for corners

Opt. rebar for windows & door: 94' (29 m)

Rebar tying bond beam to wall: 44' (13 m)

Total rebar needed: 40'- 138' (12- 42 m)

House Shapes: Domes

The original creator of the earthbag concept, architect Nader Khalili, concentrated on round buildings with curved and corbelled earthbag roofs. The domes that most people associate with this type of construction are an intrinsically very strong shape. Because they don't require other materials for a roof, domes are a very inexpensive way to build.



ABOVE RIGHT: A SMALL DOME

Domes or cone-roofed buildings have been traditionally used in hot and dry climates in the Middle East and southern Europe. They have been built of adobe or stone, like the Italian *trulli* buildings.



ABOVE: A LARGE DOME COMPLEX IN INDIA



ABOVE: THREE DOMES SUPPORT A CENTRAL ROOF

Domes can be used to support more traditional roofs as part of a complex of buildings. But the waterproofing requirements and difficulty of construction may make them unsuitable for self-help buildings in many disaster stricken areas.

Domes have several drawbacks. The most important is that they may not relate well to neighborhoods of traditional buildings with other roof shapes. Domes may be acceptable to some cultural groups in Africa or Asia with similar building forms. But people from cultures without dome shapes have frequently refused them as emergency housing, sometimes even as sheds or barns.

Domes have some structural drawbacks as well. They require flawless waterproofing in wet climates. And they are difficult to add onto or interconnect.

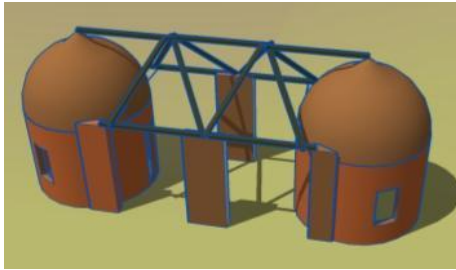

LEFT: TWO DOMES SUPPORT A TRADITIONAL ROOF

Building a dome requires more skill than building a vertical wall. Fully cement-stabilized dome roofs are safe in wet climates, but require a significant amount of cement. In wet climates they need eaves or porch roofs added to remove rainfall from the base of the building wall. And unstabilized earthen domes can develop leaks and fail.

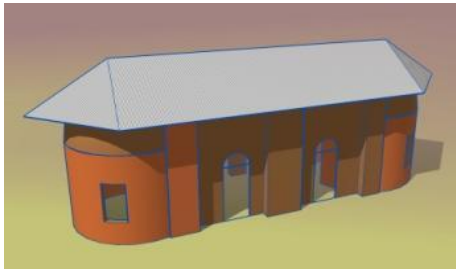

House Shapes: Overlapped Corners

If metals for corner reinforcing are too expensive the corners themselves can be extended and overlapped for extra strength with earthbag.

RIGHT: HOUSE SHAPES WITH BUTTRESSES

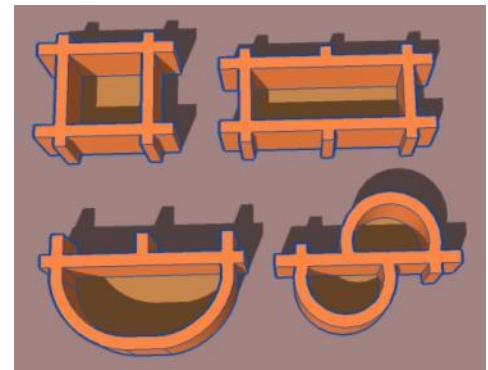

The traditional adobe buildings of the southwestern US rely on wall extensions of buttresses to strengthen corners and stiffen straight walls. African cob or adobe buildings often have thickened piers that perform the same function.

Straight-walled buildings of earthbag require extra stiffening for any straight walls longer than 10- 11' (3- 3.4 m). A single pier or buttress can be added inside or outside.



LEFT: PIERS

Interior walls woven into the exterior wall can also serve this function. Sometimes a bench interwoven with the wall is enough to stiffen it. Reinforced concrete columns can be used instead if space is very limited.

Buttresses can be shaped to reflect local styles. They may also serve to add needed shading to walls, or serve as wind catchers directing cross-breezes into openings.

RIGHT: BULBOUS AFRICAN BUTTRESSES



BELOW: SLOPING BUTTRESSES IN COSTA RICA



In some areas less frequent or lower buttressing is used in combination with temporary bracing during construction. Earthbag walls harden considerably as they dry. This is a good strategy to reduce construction time and cost for non-seismic regions, but is not recommended for areas subject to earthquakes.

RIGHT: STEPPED BUTTRESSES IN UTAH



Straight wall portions also need standard cement or tubular steel or corrugated metal bond beams.

MATERIAL COMPARISON: OVERLAPPING CORNERS

This room is rectangular 9' x 12' (2.7 x 3.4 m).

REBAR NEEDED FOR A SINGLE RECTANGULAR ROOM WITH OVERLAPPING CORNERS

108 SF / 10 M² INTERIOR AREA

No rebar needed for corners

Opt. rebar for windows & door: 94' (29 m)

Rebar tying bond beam to wall: 44' (13 m)

Rebar for concrete bond beam: 88' (27 m)

Total rebar needed: 44'- 226' (14- 69 m)

House Shapes: Compact and Symmetrical

Building shapes closer to circular or square more easily resist earthquake forces than long and narrow or bent shapes. Yet buildings that are nearer square may require longer roof rafters. Costs of reinforcement needed for longer walls should be compared to roof structure increases.

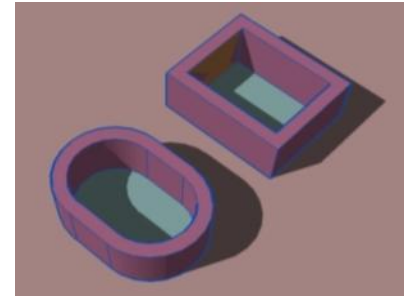

ABOVE: SAFER PLAN SHAPES



Long, bent, or irregular shaped structures are subjected to greater destructive forces in earthquakes. Symmetrical layout plans can be intrinsically stronger in earthquakes.

LEFT: LESS SAFE PLAN SHAPES

Some of the strongest buildings for earthquakes are those that are built to flex without damage. Wood frame and lashed bamboo structures with appropriate footings and good bracing survive earth tremors very well.

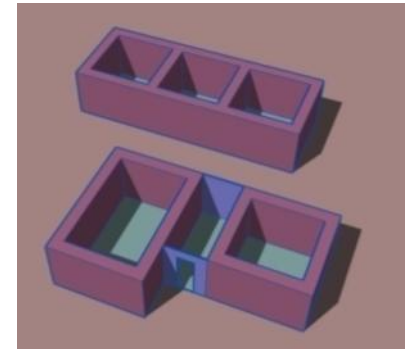

RIGHT: PARTITION LONG SHAPES OR JOIN SEPARATE SHAPES

RIGHT: BUILD STRONG WITH SEPARATE SQUARES

If odd shaped or elongated plans are needed, use separate compact shapes to create safer structures. The separate rooms will not have to strain to move with each other. After a tremor, plaster between them can be patched.

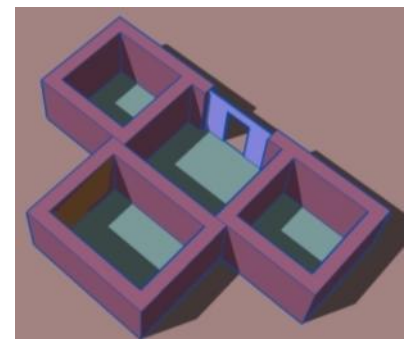

Flexible joints can be used between separate building segments or lighter walls and roofing between two separate structural rooms.^{vi} Attach connecting light walls to piers extended from building units. Build roof structures to stay up even though walls flex.

Earthquake resistance can also be improved by the type of grading used. A single level of foundation is stronger than walls and floor that step up or down.

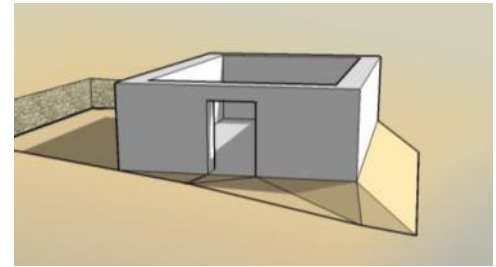

RIGHT: EQUAL CUT AND FILL FOR QUAKE RESISTANCE

A structure with a little excavation behind and a little fill in front is safer than a structure either cut deeply into a slope or placed right on the edge of a steep slope. Retaining uphill soil with a separate wall is safer in earthquakes than placing fill against the structure itself.^{vii} These will both protect it somewhat from landslides and also could

reduce the intensity of vibration during an earthquake.

The amount of windows needed must also be considered when planning for earthbag houses. Rooms in hot or hot and humid climates often need multiple windows and cross-ventilation for comfort if much time is spent inside. Ventilation is not as important for rooms in hot and dry, warm and dry, or temperate climates.^{viii}

If two window or door openings are necessary in a single wall, they can be spaced 18" (50 cm) from each side of an intersecting wall or a pier that extends 24" from the

wall. This would require a wall at least 14'3" (4.3 m) long to fit 2 windows.



RIGHT: PIERS ALLOW CLOSER WINDOW SPACING

Longer, narrower earthbag rooms can fit more windows than square buildings. Buildings one room wide can have windows on both sides. Sometimes piers and panels of vent block are needed for livable spaces.

House Shapes: Roof Shapes

Traditional roof shapes may be even more important than traditional wall shapes for matching existing neighborhoods. Plan to be able to build the kind of roof that will look good with traditional buildings, shed rain, and keep the sun off.

Often first transitional shelters have lower walls and simpler roofs than ordinary houses. An earthbag room can be covered with a temporary tarpaulin roof for immediate shelter. Earthbag walls can later be extended higher before building a permanent roof.

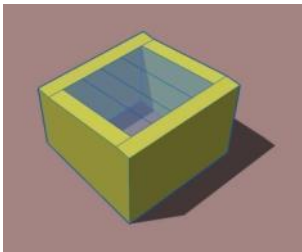

Either of the tarpaulin roofing options shown at left must include the tarp overhanging (or an additional plastic strip) at least 24" (60 cm) down the wall to protect the top of the earthbag wall from being repeatedly soaked. Tarps can be securely fastened to earthbag walls by embedding nailer plates between bags several courses below the top. Tarps must be fastened securely over their whole length without loose material hanging, if they are to survive high winds in storms of any kind.

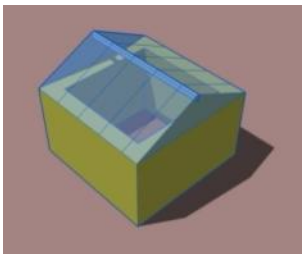

Shed roofs need rafters long enough to span the room.

Gable roofs need a stronger ridge beam, but rafters are all shorter than needed for a shed roof.



RIGHT: ROOF FRAMING FOR HAITIAN KAY

Roofs can be framed out of innovative or traditional materials. Small diameter poles of un-milled wood are often stronger than similar size milled lumber. Bamboo is very strong for its diameter and grows more quickly than wood. Bundled reeds have also been used by some cultures to support lightweight roofing.

In drier regions earth blocks can be used for Nubian style vaults. Stone can be corbelled to create conical or dome roofs. But for hazardous regions it may be safer to use light weight roofing structure and covering. Tile roofs may not be the best choice for areas subject to earthquakes.



New materials may also be useful in some situations. Ferrocement has become popular in the developing world. It can be easily used for vaulted roofs. Some versions use reinforcing fabrics as well as steel.

LEFT: FERROCEMENT VAULT ON A PHILIPPINE EARTH BAG SCHOOL



BELOW LEFT: MESH AND REBAR STRUCTURE

Magnesium cement may be useful for new kinds of roofs. This cement bonds with natural materials to form light, strong tensile structures. It can be painted on fabric or woven mats. Perhaps reeds dipped in it can be used for lighter roofing members.

Permanent roofs above earthbag walls in wet climates should include at least 12" (30 cm) overhangs. This will serve to protect the earth plaster and reduce maintenance requirements significantly. Overhangs also cast shade that keeps walls and adjoining ground cool. If the roof is well tied onto a good bond beam it can resist uplift in high storm winds.

Hip roofs require more complex framing but are more aerodynamic than gables or sheds. They can resist higher wind speeds. Extra material to build gable ends is not required. Also, there are no gable walls to be exposed to hot afternoon sun.



ABOVE: GABLE FRAMING ABOVE EARTH BAG WALLS



LEFT: HAITIAN HOUSE WITH HIP ROOF



ABOVE: A DUTCH HIP

Dutch hip roofs are a variation common in some hot areas of the world because they allow ventilation near the peak. Hot humid areas often cannot use insulation because it harbors rodents. High ceilings and vents like cupolas or dutch hips let hot air out.

RIGHT: AN OCTAGONAL POLE ROOF WITH A CUPOLA



In seismic areas a roof that does not create significant outward force is best for an earthbag house. This means that gable or hip roofs with ceiling joists or collar ties are better than shed roofs. Even for unusual shapes like round buildings there are many ways to create conical roofs that do not put outward pressure on the walls.^{ix}

Choosing House Plans

This booklet has introduced the main variables that effect strength and cost in earthbag construction.

A house is the setting for the daily life of a family. It should allow them to spend time in the ways and groupings that feel right to them. And it should be a visual symbol to the community of the family's status and relationships to the neighborhood.

To plan economical hazard-resistant housing:

1. Review the building shapes (form classes) as shown on pages 7 and 8 with those who will use the building or people from the culture.
2. Pick the materials that are the least expensive for the area from the list on pages 10 and 11. Find out the cost of the roofing materials you will use.
3. Select the type of corner treatment and bond beams from pages 15- 23.
4. Find or create plans that use the right materials and corner types.
5. Review the information on improving strength for earthquakes on page 24, or research designing for other hazards before finalizing a plan.
6. Make sure you get enough sketches of how the buildings will look to really understand. If the house isn't for you, talk them over with people from the culture and refine the plans.

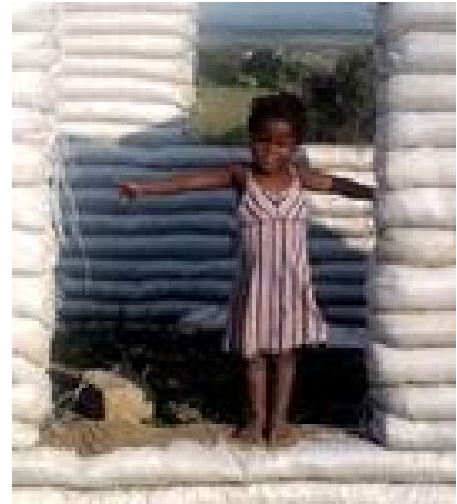

With the right information, people who need shelter should be able to choose for themselves the materials and building forms that will be best for them. Three-dimensional sketches may be better than plans and elevations. Laying bricks or sticks on the ground to outline plans may also be important.

Aid after disasters is most successful if it empowers people to choose, to dream, and to accomplish things for themselves. Earthbag's simplicity and strength can allow it to be a

part of the solution to poverty in many parts of the world. It can also be a part of the regeneration of cultures if it is adapted to serve and not merely copied.

The website at www.earthbagstructures.com includes house plans using earthbag that are available for free.

Costs

If metal rebar is in short supply strong houses can still be built of earthbag. But avoiding metal may increase needs for both labor and materials.

For our comparison transitional rooms, using overlapping corners can require almost twice as many bags as the oval room, and almost 60% more earth to fill bags. The lower figure for soil volume of an overlapping corner building is for buttresses that slope from 24" (60 cm) at their base to 12" (30 cm) at the top of the wall. The higher figure is for vertical buttresses.

Earth takes time to dig and move, and bags take time to place and tamp. Buildings with less rebar will take longer to build.

SOIL AND BAGS NEEDED FOR A SINGLE ROOM OF 108 SF / 10 M ² INTERIOR AREA		
<u>CORNER TREATMENT</u>	<u>BAGS NEEDED</u>	<u>SOIL VOLUME</u>
Rectangular Clean	590	478 cubic feet (13.4 m ³)
Oval Without Corners	419	419 cubic feet (11.7 m ³)
Overlapping Corners	818	568- 658 cubic feet (15.9- 18.4 m ³)

These amounts will not apply exactly to larger buildings. Larger buildings with clean corners may still require buttresses. If any rooms are longer than 3m the long walls will need some buttress or piers for those straight walls. They will take longer and require more soil than indicated here, but less than the proportions needed for buildings with only overlapping corners.

Cost and availability of Portland cement, sand, and aggregate to use in a reinforced concrete bond beam may also influence choices about building shape.

Rectangular buildings can use metal or wood bond beams instead of reinforced concrete. Buildings with curving walls need either a traditional reinforced concrete bond beam or an alternative stabilized earth and tubular bag one. Although overlapping corner buildings require more material for the buttresses at their corners, their requirements for bond beams are the same as 'clean' corner buildings. Bond beams only cap the walls and not the buttresses.

CEMENT NEEDED FOR BOND BEAMS		
SINGLE ROOM OF 108 SF / 10 M ² INTERIOR AREA		
<u>CORNER TREATMENT</u>	<u>TYPE OF BOND BEAM</u>	<u>CEMENT NEEDED</u>
Rectangular Clean	Reinforced Concrete	4.9 cubic feet (0.14 m ³)
Oval Without Corners	Reinforced Concrete	4.4 cubic feet (0.12 m ³)
Round Alternate 11'8" diameter	Tubular bags with cement stabilized earth (6- 15% Portland)	1.4- 4.8 cubic feet (0.04- 0.13 m ³)
Overlapping Corners	Reinforced Concrete	4.9 cubic feet (0.14 m ³)

If round rooms are desired, they can take advantage of tubular bags and stabilized earth for a bond beam. Wood will not be needed for forms, or sand and gravel for the mix. But using two layers of bags to sandwich barbed wire makes this alternate bond beam a little thicker than a reinforced concrete one. Tubes usually cost a little more than separate bags because they can't be discounted misprints like separate bags.

Soils vary greatly in the amounts of Portland cement needed to stabilize them. Some soils need less cement if lime is added. The amount of cement can only be found by creating several test mixes and letting them fully cure. If a soil requires little cement to be stabilized, round buildings can require less cement as well as less metal than any other shape. The lower figure for cement needed assumes the use of 12" wide tubular bags.

The larger number assumes the use of 17" wide tubes filled $\frac{3}{4}$ full. 12" wide bags are too narrow for building walls taller than 7', but can be used for low retaining walls.

Details and Advice

The techniques for construction and types of materials used are only introduced in this booklet. Details relevant to aid work are more fully described and discussed on the www.earthbagstructures.com website.

Additional booklets and articles describe basic earthbag techniques, and advise about selecting shelter plans, preparing sites for earthbag homes, and other relevant topics.



Those who are new to earthbag construction should carefully read the information at Earthbag Structures, and possibly search the site at www.earthbagbuilding.com for descriptions of techniques and processes as well as plans and videos.

A worthwhile manual for basic earthbag construction and earth plastering techniques is Earthbag Building: The Tools, Tricks and Techniques by Kaki Hunter, Donald Kiffmeyer, New Society Publishers: 2004. This is available in English as a pdf ebook at http://www.ebooks.com/ebooks/book_display.asp?IID=256395

If you are involved in or planning an earthbag project for disaster relief or aid to Haiti or another third world community, request a membership in the Earthbag Structures private shelter blog to discuss issues and get additional help.

Additional Information:

The first step to planning aid for any people is to begin to understand their culture. Their relational style, family and community social structures, and types of agriculture and crafts all influence their buildings.

For general information about the differences between cultures and communication styles, *Foreign to Familiar: A Guide to Hot- and Cold-Climate Cultures*, Sarah H. Lanier, McDougal Publishing, Hagerstown MD, 2000 is an excellent brief introduction. This information may change how you think about housing and other needs as well as how you interact with people of another culture.

Researching the shapes of their traditional and modern buildings is an important step towards understanding why people build as they do. The best understanding comes from discussing building plans with the people themselves, and letting their architects or building designers or house builders select and refine any plans.

This book was prepared to be helpful for rebuilding in Haiti after the 2010 earthquakes. Few books at this date include information about Haitian styles of building. [Haitian Wisdom for Aid Buildings](#), by Patti Stouter has 29 pages about Haitian types of houses and the cultural forces that shape them. It is available online at www.scribd.com/doc/28552969/Haitian-Wisdom. It also contains a list of web sites and articles about Haitian vernacular architecture.

Acknowledgements

Earthbag may never be a big industrial process. There have been no large industrial associations putting money into engineering tests or promotion. It has been promoted by a grassroots response of people who have freely shared their experiences.

We are indebted to professors and students at West Point, Queen's University, and Howard University as well as many members of Engineers Without Borders for help with testing. Many thanks are due as well to other builders and networkers and educators and designers who have helped to prepare and bring this information to the public.

About the Authors

This book is dedicated to the people of Haiti who deserve to find a way to shelter themselves both well and beautifully.

Patti Stouter is a relative newcomer to the world of earthbag construction. She is a landscape architect with some experience in site and building design for African locations. Long-term interests have included climate-responsive design and color in architecture. She lives north of NY City in the Hudson Valley and usually commutes to drafting and design work supporting literacy and Bible translation for Wycliffe Associates. She speaks some French, and can be contacted at handshapedlandATyahoo.com.

Kelly Hart has extensive experience in building with earthbag as well as with traditional construction. He is the founder and webmaster of www.greenhomebuilding.com and joined with Owen Geiger to start www.earthbagbuilding.com. This site has had a large part in spreading and improving earthbag technology. Kelly has a background in video and media and lives in Colorado now. He can be reached at kellyhartATgreenhomebuilding.com.

Owen Geiger has had a lifelong goal of alleviating substandard housing by using natural building materials. He has experience with Builders without Borders and Habitat for Humanity as well as two engineering degrees and a PhD in Social and Economic Development. He uses his 30 years of experience in construction to teach, consult with aid organizations, write about construction, build, and design buildings from his home in Thailand. Owen can be reached at strawhousesATyahoo.com.

Images

The following photographs from Wikimedia Commons used by permission, retrieved at <http://commons.wikimedia.org/>:

Cover bottom by Master Sergeant Jeremy Lock, USAF.

Page 6 top and bottom by Remi Kaupp

Page 9 by Clindberg

Photographs on pages 3-5, 8 bottom, 10-12, 14-16, 19- 23, 27-29, 31 and 34 are all from www.earthbagbuilding.com used by permission. Many thanks to the great designers and builders who shared these photos!

The photograph on page 7 by Christine T. Neptune, used by permission.

The photograph on page 27 bottom from St. Monica's in Haiti, used by permission.

The photographs on page 8 right and page 26 by Jay D. Edwards, used by permission.

Computer sketches by Kelly Hart on page 16 top, page 17 top, and page 18, used by permission.

Remaining computer sketches by Patti Stouter.

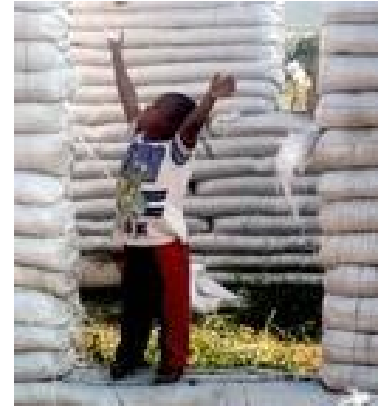

Notes:

ⁱ <http://www.earthbagbuilding.com/articles/posttsunami.htm> has a free post-tsunami building plan.

ⁱⁱ Blondet, Marcial, Gladys Villa Garcia M., and Smetlana Brzev, *Earthquake Resistant Construction of Adobe Buildings*, (Oakland, CA: Earthquake Engineering Research Institute, 2003) 8 accessed 3/1/2010 at www.world-housing.net.

ⁱⁱⁱ New Zealand has a set of Earth Building Standards that include specifications for buildings that do not require engineering. They are available at <http://www.earthbuilding.org.nz/standards.htm>

^{iv} Minke, Gernot, *Building With Earth: Design and Technology of a Sustainable Material*, (Basel: Birkhauser, 2006) 15

^v Minke, Gernot, *Construction Manual for Earthquake Resistant Houses Built of Earth*, (Eschborn, Germany: GATE- Building Advisory Service and Information Network, 2001) 10, 17 Bowed wall buildings is a reference to work by Syed Sibtain, 1985.

^{vi} Minke, (2001) 9

^{vii} Minke, (2001) 8

^{viii} Brown, G.Z., and Mark DeKay, *Sun, Wind, and Light, second edition*, (NY: John Wiley and Sons, 2001) 23 and 146

^{ix} Hunter, Kaki, and Donald Kiffmeyer, *Earthbag Building: The Tools, Tricks and Techniques*, (Gabriola Island, BC: New Society Publishers, 2004) 113- 119