

BIOSAND FILTER MANUAL

DESIGN, CONSTRUCTION, INSTALLATION, OPERATION AND MAINTENANCE

A CAWST TRAINING MANUAL
September 2009 Edition





12, 2916 – 5th Avenue, Calgary, Alberta, T2A 6K4, Canada
phone: + 1 403.243.3285 • fax : + 1 403.243.6199
email: cawst@cawst.org • website: www.cawst.org

CAWST is a Canadian non-profit organization focused on the principle that clean water changes lives. Safe water and basic sanitation are fundamentals necessary to empower the world's poorest people and break the cycle of poverty. CAWST believes that the place to start is to teach people the skills they need to have safe water in their homes. CAWST transfers knowledge and skills to organizations and individuals in developing countries through education, training and consulting services. This ever expanding network can motivate individual households to take action to meet their own water and sanitation needs.

One of CAWST's core strategies is to make knowledge about water common knowledge. This is achieved, in part, by developing and freely distributing education materials with the intent of increasing its availability to those who need it most.

This document is open content and licensed under the Creative Commons Attribution Works 3.0 Unported License. To view a copy of this license, visit <http://creativecommons.org/licenses/by/3.0/> or send a letter to Creative Commons, 171 Second Street, Suite 300, San Francisco, California 94105, USA.

You are free to:

- Share - to copy, distribute and transmit this document
- Remix - to adapt this document

Under the following conditions:

- Attribution. You must give credit to CAWST as the original source of this document (but not in any way that suggests that CAWST endorses you or your use of this document).

CAWST and its directors, employees, contractors, and volunteers do not assume any responsibility for and make no warranty with respect to the results that may be obtained from the use of the information provided.

Under ideal circumstances, the biosand filter can produce high quality drinking water. However, this cannot always be assured or guaranteed due to variations in the construction, installation, operation and maintenance of the filter. CAWST shall not be liable to anyone whatsoever for any damage resulting from reliance on any information provided in this document or attachments thereto. This also applies to the consumption of water from the biosand filter. It should also be noted that the biosand filter cannot be upon to remove certain or all forms of water contamination.

Cover photo: Tommy Ngai (pictured: Ganesh Harijan, Nepal)

Table of Contents

Acronyms	ii
Abbreviations	ii
Measurement Conversions	ii
Glossary	iii
1 The Multi-Barrier Approach for HWTS	1
2 Biosand Filter Overview	2
2.1 What is the Biosand Filter?	2
2.2 History of the Biosand Filter	2
2.3 Biosand Filter Components	2
2.4 How Does the Biosand Filter Work?	3
2.5 How Well Does the Biosand Filter Work?	5
3 Biosand Filter Operation	6
3.1 Water Source	6
3.2 The Biolayer	6
3.3 Filter Loading Rate	7
3.4 Pause Period	7
3.5 Standing Water Layer	7
3.6 Maintenance	8
3.7 Disinfection	8
3.8 Safe Water Storage	8
4 Version 10.0 Concrete Biosand Filter	10
5 Construction, Installation, Operation and Maintenance Instructions	11
5.1 Construction Safety	12
Stage A – Obtain Tools and Materials	14
Stage B – Locate the Sand and Gravel	17
Stage C – Prepare the Sand and Gravel	19
Stage D – Construct the Filter Box	25
Stage E – Construct the Diffuser	32
Stage F – Construct the Lid	43
Stage F – Construct the Lid	44
Stage G – Installation	45
Stage G – Installation	46
Stage H – Operation, Maintenance and Follow-Up	53
6 References	58

Appendix 1: Concrete Biosand Filter Version 10.0 Mold Design

Appendix 2: Sieve Set Construction

Appendix 3: Sand Sieve Analysis

Appendix 4: Manufacturing and Installation Monitoring Forms

Appendix 5: Follow Up Visit Monitoring Forms

Appendix 6: Costing and Pricing Forms

Acronyms

CAWST	Centre for Affordable Water and Sanitation Technology
ES	effective size
HWT	household water treatment
ID	inner diameter
NTU	nephelometric turbidity units
OD	outer diameter
QY	quantity
SODIS	solar disinfection
UC	uniformity coefficient
UV	ultraviolet

Abbreviations

cm	centimetre
ft	foot
kg	kilogram
L	litre
m	metre
min	minute
mm	millimetre
lb	pound
'	foot
"	inch

Measurement Conversions

Length or Distance

1 foot = 0.30 metres	1 inch = 2.54 cm	1 mm = 0.1 cm
1 metre = 3.28 feet	1 cm = 0.39 inches	1 cm = 10 mm

Volume

1 gallon = 3.78 litres
1 litre = 0.26 gallons

Area

1 m ² = 10.76 ft ²
1 ft ² = 0.09 m ²

Flow Rate

1 litre/minute = 60 seconds/litre

Glossary

Adsorption	When a contaminant attaches itself to the surface of a solid.
Bacteria	Single-celled microorganisms, typically a few micrometres in length.
Biolayer	The biological layer formed at the sand-water interface of slow sand filters. It is colonized by microorganisms including bacteria, protozoa, algae, and diatoms. Also called the schmutzdecke.
Cement	A powder (made of limestone and clay) that is mixed with water, sand and gravel to make concrete.
Concrete	A strong construction material made of cement, sand and gravel.
Contamination	Pollution of water due to human or natural causes.
Disinfection	Any process that removes, deactivates or kills pathogens found in water. It is last step of the household water treatment process, after sedimentation and filtration.
Dissolved solids	Small particles which are dissolved in water. They cannot be removed by sedimentation or filtration.
Effective size	The size opening read from the grain-size distribution graph that will just pass 10% of the sand.
Filtration	The process of allowing water to pass through layers of a porous material such as sand, gravel or cloth to remove suspended solids and pathogens. It is the second step of the household water treatment process, done after sedimentation and before disinfection.
Flow rate	The time it takes to fill a specified container of water, often a 1 litre container. Flow rate is measured when the biosand filter is filled with water.
Galvanized steel	A thin sheet of steel that is coated with zinc to prevent it from rusting.
Hydraulic head	The driving force which causes water to move from one place to another due to its pressure and elevation. Head is usually measured as a water surface elevation, expressed in units of length.
Hygiene	Practices, such as hand washing, that help ensure cleanliness and good health.

Implementation	The process of carrying out a plan. The implementation phase happens after the plan has been created.
Nutrient	Any substance used by microorganisms to live and grow. The term is generally applied to nitrogen and phosphorus in contaminated water, but can be used to describe other chemicals.
Pathogen	Any living organism that causes disease. Pathogens commonly found in water include bacteria, viruses, protozoa and helminths.
Pore	The small spaces between the sand grains that allow water to pass through.
Predation	Where a predator (a microorganism that is hunting) feeds on its prey (the microorganism that is attacked).
Sanitation	Maintaining clean, hygienic conditions that help prevent disease through services such as garbage collection, wastewater disposal, and using latrines.
Sedimentation	The process used to settle out suspended solids in water under the influence of gravity.
Siphon	A tube bent to form two legs of unequal length by which a liquid can be transferred to a lower level over an intermediate elevation by the pressure of the atmosphere in forcing the liquid up the shorter branch of the tube immersed in it while the excess of weight of the liquid in the longer branch when once filled causes a continuous flow
Suspended solids	Small solid particles which float in water, causing turbidity. They can be removed by sedimentation or filtration.
Turbidity	Caused by suspended solids, such as sand, silt and clay, floating in water. Turbidity is the amount of light that is reflected off these suspended solids which make the water look cloudy or dirty. Turbidity is measured in nephelometric turbidity units (NTU).
Uniformity coefficient	Size opening read from the grain-size distribution graph that will pass 60% of the sand (d60 value) divided by the size opening that will pass 10% of the sand (d10 value). It is a measure of how well or poorly sorted the sand is.
Water quality	The chemical, physical, and microbiological characteristics of water. The quality of water to be used depends on the purpose for which it is intended.

1 The Multi-Barrier Approach for HWTS

Using the **multi-barrier approach** is the best way to reduce the risk of drinking unsafe water. Each step in the process, from source protection, to water treatment and safe storage, provides an incremental health risk reduction. The household water treatment process includes: sedimentation, filtration and disinfection.

More often than not, people focus on a particular technology that is directed towards one step rather than considering the water treatment process as a whole. While individual technologies, like the biosand filter, can incrementally improve drinking water quality, the entire process is essential in providing the best water quality possible.

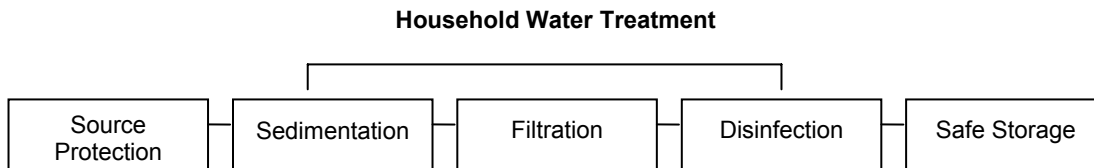

- Sedimentation to remove larger particles and often > 50% of pathogens
- Filtration to remove smaller particles and often > 90% of pathogens
- Disinfection to remove, deactivate or kill any remaining pathogens

The household water treatment process is primarily focused on removing pathogens from drinking water – the biggest water quality issue around the world. While improving the microbiological quality, there are some technologies that may also be able to remove certain chemicals as a secondary benefit, such as arsenic and iron.

Although all five components of the multi-barrier approach greatly help to improve the quality of drinking water, this manual focuses primarily on filtration, which should be used in combination with the other components to ensure healthy, uncontaminated water.



Using chlorine to disinfect water



SODIS, or solar disinfection, can be used as part of the multi-barrier approach

2 Biosand Filter Overview

2.1 What is the Biosand Filter?

The biosand filter (BSF) is an adaptation of the traditional slow sand filter, which has been used for community water treatment for almost 200 hundred years. The biosand filter is smaller and adapted for intermittent use, making it suitable for households. The filter container can be made of concrete or plastic and is filled with layers of specially selected and prepared sand and gravel.

2.2 History of the Biosand Filter

Dr. David Manz developed the household biosand filter in the 1990s at the University of Calgary, Canada. Dr Manz has trained many organizations on the design, construction, installation, operation and maintenance of the biosand filter. He also co-founded CAWST in 2001 to provide the professional services needed for the humanitarian distribution of the filter in developing countries. As of June 2009, CAWST estimates that over 200,000 biosand filters have been implemented in more than 70 countries around the world.

2.3 Biosand Filter Components

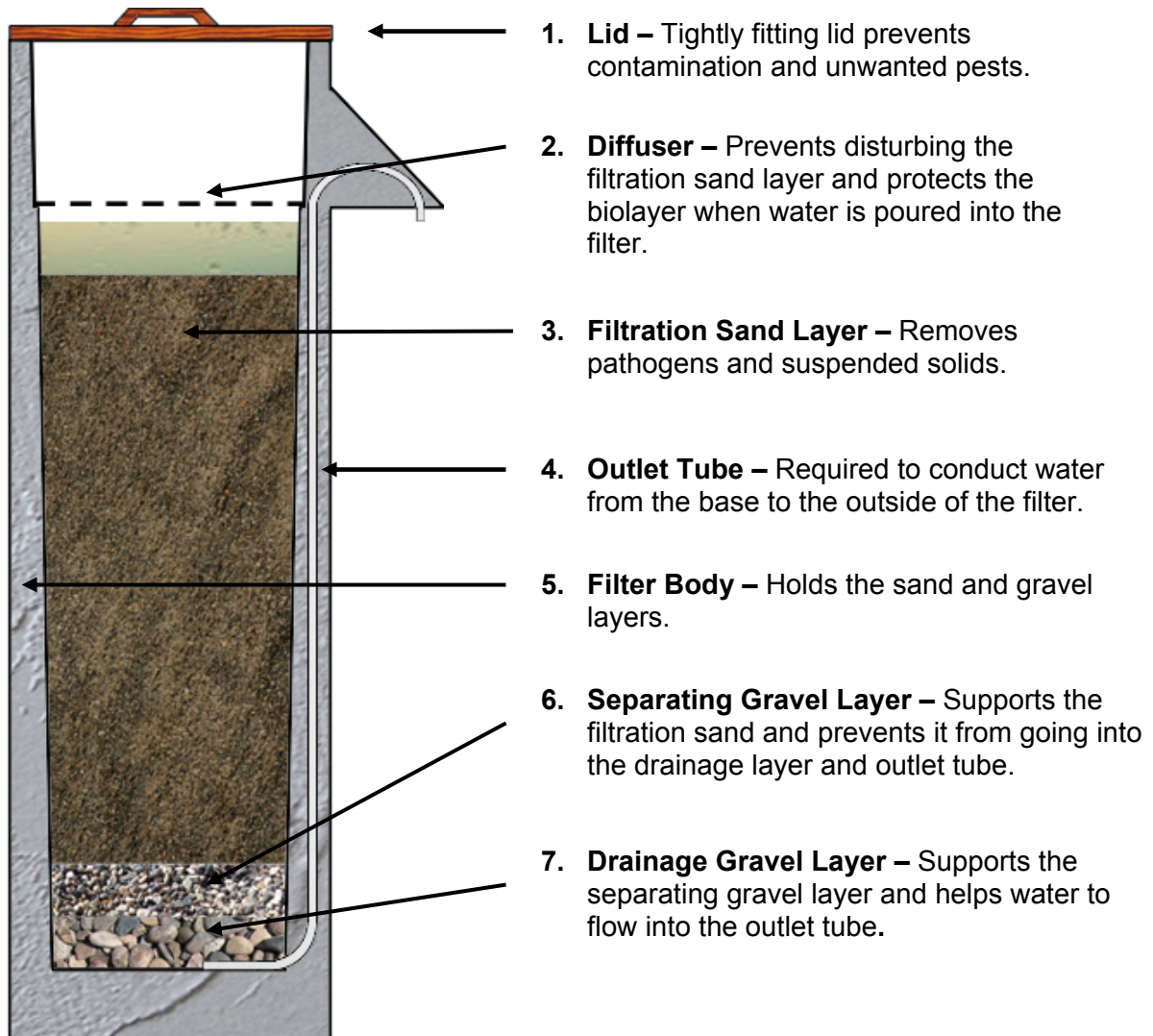

2.4 How Does the Biosand Filter Work?

The biosand filter has five distinct zones: 1) inlet reservoir zone, 2) standing water zone, 3) biological zone, 4) non-biological zone, and 5) gravel zone.

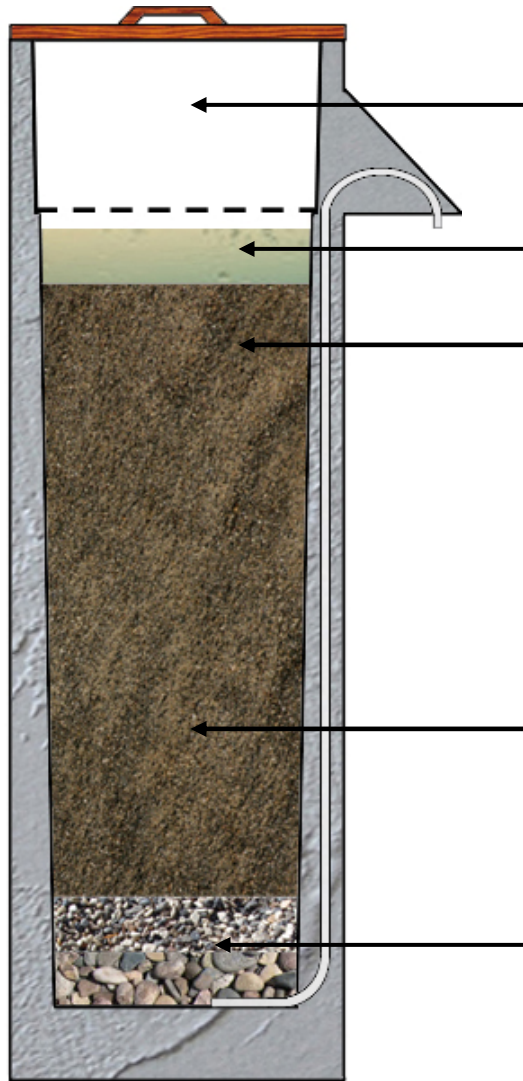

1. Inlet Reservoir Zone - Where water is poured into the filter.

2. Standing Water Zone – This water keeps the sand wet while letting oxygen pass to the biolayer.

3. Biological Zone – Develops at the top 5-10 cm (2-4”) of the sand surface. The filtration sand removes pathogens, suspended particles and other contaminants.

As in slow sand filters, a biological layer of microorganisms (also known as the biolayer or schmutzedecke) develops at the top 1-2 cm (0.4-0.8”) of the sand surface.

4. Non-Biological Zone – Contains virtually no living microorganisms due to the lack of nutrients and oxygen.

5. Gravel Zone – Holds the sand in place and protects the outlet tube from clogging.

Pathogens and suspended solids are removed through a combination of biological and physical processes that take place in the biolayer and within the sand layer. These processes include: mechanical trapping, predation, adsorption, and natural death.

- **Mechanical trapping.** Suspended solids and pathogens are physically trapped in the spaces between the sand grains.
- **Predation.** Pathogens are consumed by other microorganisms in the biolayer.
- **Adsorption.** Pathogens become attached to each other, suspended solids in the water, and the sand grains.
- **Natural death.** Pathogens finish their life cycle or die because there is not enough food or oxygen for them to survive.

Contaminated water is poured into the reservoir on an intermittent basis. The water slowly passes through the diffuser and percolates down through the biolayer, sand and gravel. Treated water naturally flows from the outlet tube.

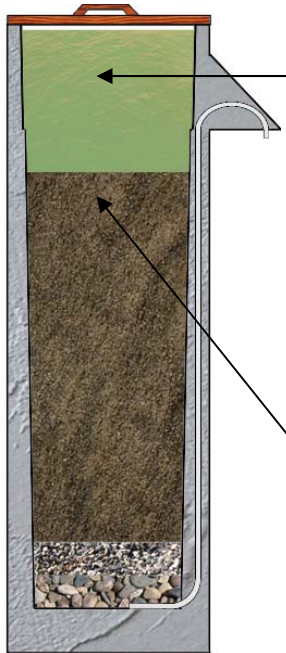

During the Run

The high water level pushes the water through the diffuser and filter (also called the hydraulic head). The water level in the reservoir goes down as it flows evenly through the sand. The flow rate will slow down over time because there is less pressure to force the water through the filter.

The inlet water contains dissolved oxygen, nutrients and contaminants. It provides the oxygen required by the microorganisms in the biolayer.

Larger suspended particles and pathogens are trapped in the top of the sand and they partially plug the pore spaces between the sand grains. This also causes the flow rate to slow down.

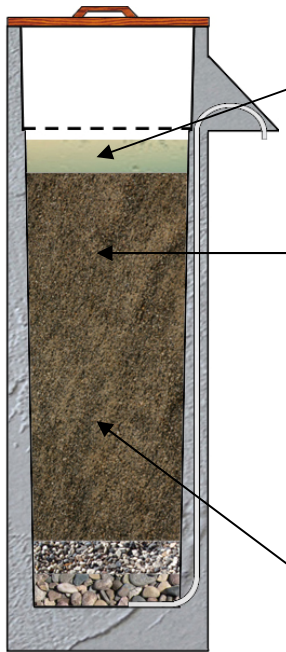

Pause Period

The water finally stops flowing. The standing water layer will be at the same height as the end of the outlet tube. Some oxygen from the air diffuses through the standing water to the biolayer.

The pause period allows time for microorganisms in the biolayer to consume the pathogens and nutrients in the water. The flow rate through the filter is restored as they are consumed. If the pause period is too long, the biolayer will eventually consume all of the pathogens and nutrients and eventually die off. This will reduce the removal efficiency of the filter when it is used again. The pause period should be a minimum of 1 hour after the water has stopped flowing up to a maximum of 48 hours.

Pathogens in the non-biological zone die off due to the lack of nutrients and oxygen.

2.5 How Well Does the Biosand Filter Work?

Water naturally contains many living things. Some are harmless and others can make people sick. Living things that cause disease are also known as **pathogens**. They are sometimes called other names, such as microorganisms, microbes or bugs, depending on the local language and country. There are four different categories of pathogens that are shown in Table 1: **bacteria, viruses, protozoa and helminths**.

The physical characteristics of drinking water are usually things that we can measure with our senses: turbidity, colour, taste, smell and temperature. **Turbid water looks cloudy, dirty or muddy**. Turbidity is caused by sand, silt and clay that are floating in the water. Drinking turbid water will not make people sick by itself. However, viruses, parasites and some bacteria can sometimes attach themselves to the suspended solids in water. **This means that turbid water usually has more pathogens so drinking it increases the chances of becoming sick.**

The following Table 1 shows the biosand filter treatment efficiency in removing pathogens and turbidity.

Table 1: Biosand Filter Treatment Efficiency

	Bacteria	Viruses	Protozoa	Helminths	Turbidity	Iron
Laboratory	Up to 96.5% ^{1,2}	70 to >99% ³	>99.9% ⁴	Up to 100% ⁵	95% <1 NTU ¹	Not available
Field	87.9 to 98.5% ^{6,7}	Not available	Not available	Up to 100% ⁵	85% ⁷	90-95% ⁸

1 Buzunis (1995)

2 Baumgartner (2006)

3 Stauber et al. (2006)

4 Palmateer et al. (1997)

5 Not researched. However, helminths are too large to pass between the sand, up to 100% removal efficiency is assumed

6 Earwaker (2006)

7 Duke & Baker (2005)

8 Ngai et al. (2004)

Health impact studies estimate a 30-47% reduction in diarrhea among all age groups, including children under the age of five, an especially vulnerable population (Sobsey, 2007; Stauber, 2007).

3 Biosand Filter Operation

The following sections describe how to properly use the biosand filter to ensure the highest level of treatment efficiency.

3.1 Water Source

The biosand filter can be used with any water source such as rainwater, deep groundwater, shallow groundwater, rivers, lakes or other surface water. The source should be the cleanest available since the filter is not able to remove 100% of the pathogens and turbidity. If the source water is very contaminated, the filtered water may still have some contaminants.

Over time, the biolayer becomes adapted to a certain amount of contamination from the source water. If source water with a different level and type of contamination is used, the biolayer may not be able to consume all of the pathogens. It may take the biolayer several days to adapt to the new source water, level of contamination, and nutrients. **It is recommended to consistently use the same source water to ensure the highest treatment efficiency.**

The turbidity of the source water is also a key factor in the operation of the filter. Higher turbidity levels will plug the filtration sand layer more quickly. As such, maintenance will be required more often to ensure a convenient flow rate for the user. **It is recommended to use a sedimentation method if the source water turbidity is greater than 50 NTU.** A simple test to measure the turbidity is to use a 2 litre clear plastic bottle filled with the source water. Place this on top of large print such as the CAWST logo on this manual. If you can see this logo looking down through the top of the bottle, the water probably has a turbidity of less than 50 NTU.

3.2 The Biolayer

The biolayer is the key component of the filter that removes pathogens. Without it, the filter removes about 30-70% of the pathogens through mechanical trapping and adsorption. The ideal biolayer will increase the treatment efficiency up to 99% removal of pathogens.

It may take up to 30 days for the biolayer to fully form. During that time, both the removal efficiency and the oxygen demand will increase as the biolayer grows. The biolayer is NOT visible – it is NOT a green slimy coating on top of the sand. The filtration sand may turn a darker colour, but this is due to the suspended solids that have become trapped.

The water from the filter can be used during the first few weeks while the biolayer is being established, but disinfection, as always, is recommended during this time.

Figure 1 illustrates how the biolayer works. The process may vary as some filters require a shorter or longer period of time to establish the biolayer depending on the amount and source of water being used.

Figure 1: How the Biolayer Works

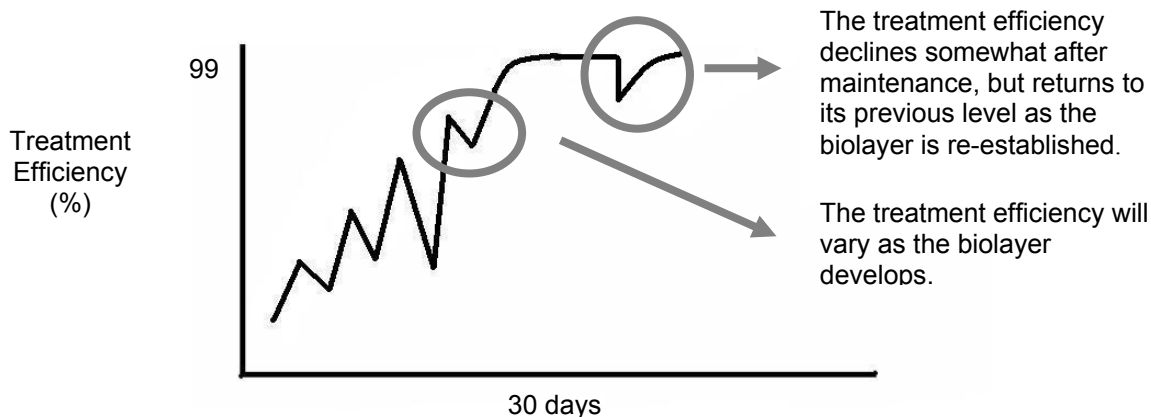

3.3 Filter Loading Rate

The biosand filter has been designed to allow for a filter loading rate (flow rate per square metre of sand surface area) which has proven to be effective in laboratory and field tests. There is a recommended filter loading rate for each biosand filter design. For the concrete Version 10 biosand filter, it has been determined to be not more than 400 litres/hour/square metre.

3.4 Pause Period

The biosand filter is most effective and efficient when operated intermittently and consistently. **The pause period should be a minimum of 1 hour after the water has stopped flowing up to a maximum of 48 hours.**

The pause period is important because it allows time for the microorganisms in the biolayer to consume the pathogens in the water. As the pathogens are consumed, the flow rate through the filter may be restored. If the pause period is extended for too long, the microorganisms will eventually consume all of the nutrients and pathogens and then eventually die off. This will reduce the removal efficiency of the filter when it is used again.

3.5 Standing Water Layer

Correct installation and operation of the biosand filter requires a standing water depth of approximately 5 cm (2") above the sand during the pause period. The standing water depth can be 4-6 cm, but ideally it should be at 5 cm (2").

A water depth of greater than 5 cm (2") results in lower oxygen diffusion and consequently a thinner biolayer. A high water level can be caused by a blocked outlet tube, an insufficient amount of sand installed in the filter or the sand settling in the first few weeks of use.

A water depth less than 5 cm (2") may evaporate quickly in hot climates and cause the biolayer to dry out. A low water level may be caused by too much sand being put into the filter during installation.

3.6 Maintenance

The spaces between the sand grains will become plugged with suspended solids over time. As a result, the flow rate will slow down. **A slower flow rate is not an issue in terms of water quality.** In fact, the slower the flow rate, the better the water quality. However, it may become slow enough that it is inconvenient for the user and they may choose to not use the filter at all.

When the flow becomes much slower than the recommended rate, the user will need to do basic maintenance (called the “swirl and dump”) to restore it. As well, users will need to clean the outlet tube, safe storage container, diffuser, lid, and outside surfaces of the filter on a regular basis.

Instructions on how to do maintenance are provided in Stage H of this manual.

3.7 Disinfection

Although the water may look clear after filtration, it is still necessary to disinfect it to ensure the best water quality possible. The biosand filter removes most, but not all of the bacteria and viruses. The most common methods used around the world to disinfect drinking water are:

- Chlorine disinfection
- Solar disinfection (SODIS)
- Solar pasteurization
- Ultraviolet (UV) disinfection
- Boiling

When water has high levels of turbidity, pathogens “hide” behind the suspended solids and are difficult to kill using chemical, SODIS and UV disinfection. The biosand filter reduces the turbidity and is a necessary step to improve the effectiveness of these disinfection methods.

3.8 Safe Water Storage

People do a lot of work to collect, transport and treat their drinking water. Now that the water is safe to drink, it should be handled and stored properly to keep it safe. If it's not stored safely, the treated water quality could become worse than the source water and may cause people to get sick. **Recontamination of safe drinking water is a common issue around the world** and has been documented in several cases.

Safe storage means keeping treated water away from sources of contamination, and using a clean and covered container. It also means drinking water from the container in a way so that people don't make each other sick. The container should prevent hands, cups and dippers from touching the water, so that the water isn't recontaminated.

There are many designs for water containers around the world. A safe water storage container should have the following qualities:

Biosand Filter Manual

- Strong and tightly fitting lid or cover
- Tap or narrow opening at the outlet
- Stable base so it doesn't tip over
- Durable and strong
- Should not be transparent (see-through)
- Easy to clean

Other safe water handling practices include:

- Using a container to collect and store untreated water and using it only for untreated water
- Using a different container to store treated water - never use this container for untreated water
- Frequently cleaning out the storage container with soap or chlorine
- Storing treated water off the ground in a shady place in the home
- Storing treated water away from small children and animals
- Pouring treated water from the container instead of scooping the water out of it
- Drinking treated water as soon as possible, preferably the same day

Sometimes it is difficult for rural and poor households to find or buy a good storage container. **The most important things are to make sure that it is covered and only used for treated water.**

4 Version 10.0 Concrete Biosand Filter

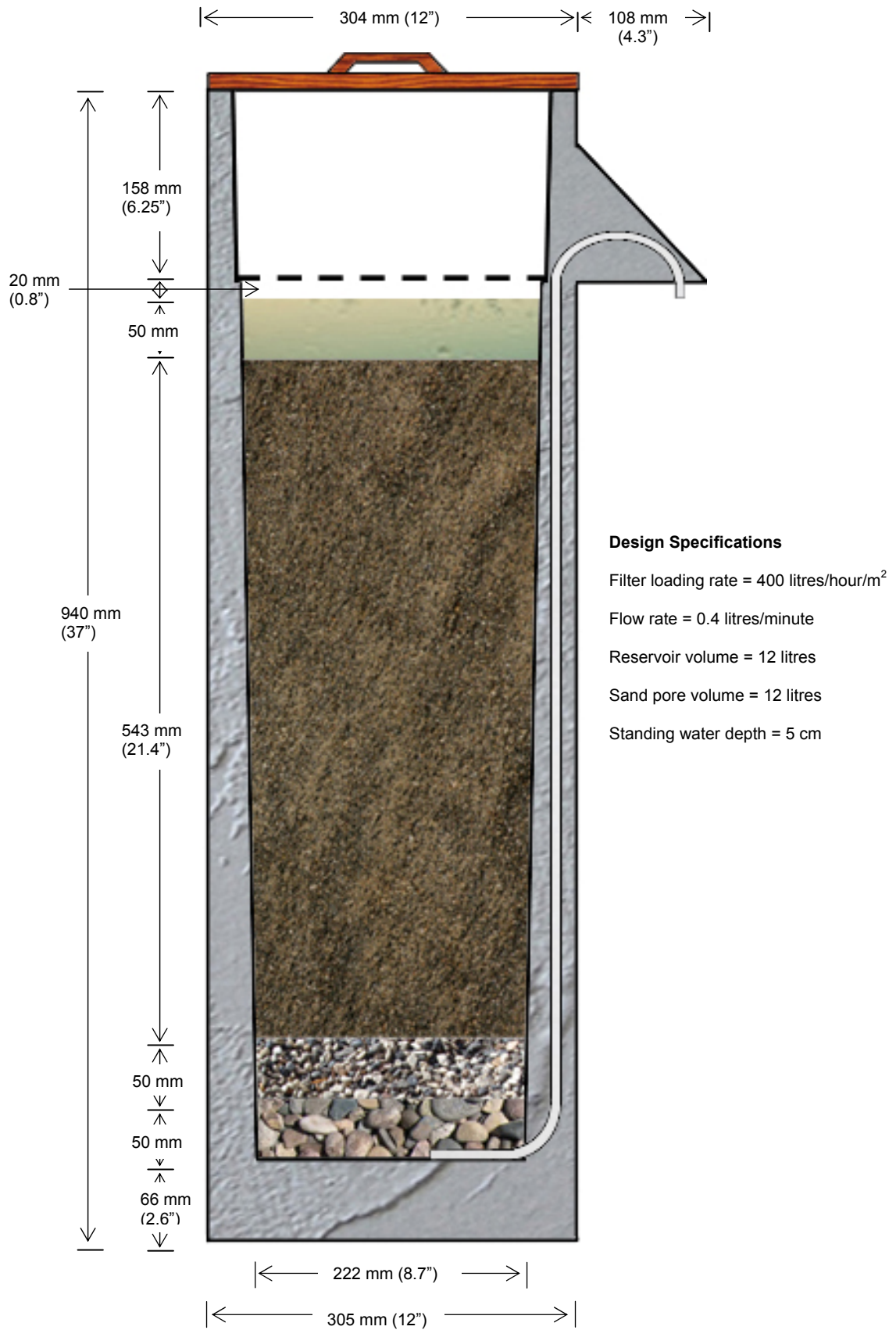

5 Construction, Installation, Operation and Maintenance Instructions

The following chart is an overview of the stages that are required to construct, install, operate and maintain the Version 10.0 concrete biosand filter. In the case where other filter bodies are used, Stages D, E and F can be changed with the other Stages remain the same.

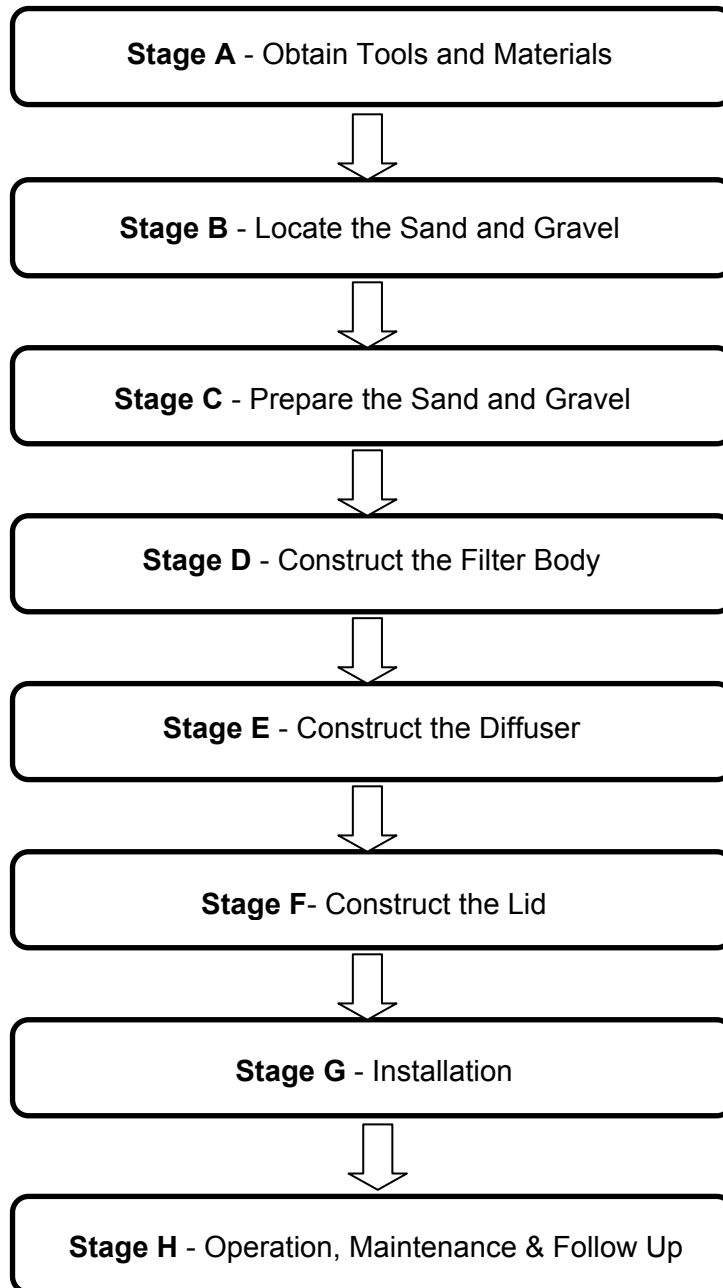

5.1 Construction Safety

It is important to work safely and avoid the potential for injury while constructing a biosand filter. You will be using sharp tools, lifting heavy pieces, and handling potentially dangerous materials. When properly managed, the risks involved in these tasks can be reduced to avoid injuries.

The work place should have a first aid kit available at all times. At the very least, it should be stocked with bandages, gauze and disinfectants. Medical assistance contact numbers should be posted in a visible location.

Cement

Cement can hurt you if it comes into contact with your skin, eyes, or is inhaled. Cement usually contains a metal called hexavalent chromium. This metal causes allergic dermatitis, or inflammation of the skin.

When you empty a bag of cement, the dust can irritate your skin. The dust reacts with body sweat or damp clothing to form a corrosive solution. Cement dust can also get in your eyes, causing redness, burns, or blindness. Inhaling cement dust irritates your nose and throat. It can also cause choking and troubles with breathing. Cement is also hazardous when it's wet - in mortar or concrete. If it gets inside your boots or gloves, or soaks through your clothes, it can cause burns and skin ulcers. The burns caused by cement may be slow and you may not feel anything until several hours later. That's why **it is important to wash cement off your skin right away.**

What to wear:

- Wear eye protection for mixing, pouring, and other work with dry cement
- Wear a face mask to prevent cement dust inhalation
- Wear gloves
- Wear long sleeves and full-length pants
- Pull sleeves over gloves
- Tuck pants into boots when working with wet mortar or concrete

What to do:

- Work upwind from cement dust
- Remove rings and watches because cement dust can collect underneath and burn your skin
- Remove any clothing contaminated by cement
- When your skin comes in contact with cement, wash with cold running water as soon as possible. Flush out any open sores or cuts. Get medical attention if your skin still feels like it's burning.
- After working with cement, always wash your hands before eating, smoking, or using the toilet
- **If your eyes are exposed to cement, rinse with cold clean water for at least 15 minutes. Get medical attention if necessary.**

Chlorine

Chlorine on your skin may cause irritation unless it is rinsed off immediately and flushed with large amounts of water. Any contaminated clothing should be removed and washed before being reused. Chlorine that gets in your eyes may cause inflammation of your throat, nose and lungs. **If your eyes are exposed to chlorine, rinse with clean water for at least 15 minutes while lifting the upper and lower lids occasionally. It is also recommended to get medical attention.**

Tools

While all of the hand tools used to construct the filter are small, they still have the potential to cause injury. Safely storing and using the tools correctly is the best way to prevent injuries. Use caution with sharp tools (e.g. saws, tin snips and knives) to prevent cuts. Sharp edges of sheet metal can also cause cuts. Be aware of smashing and crushing injuries to hands when using hammers and wrenches.

Stage A – Obtain Tools and Materials

A good set of tools is needed to easily and properly construct and install a concrete biosand filter. All you need are hand tools, which will provide you with many years of useful life if they are properly maintained and handled.

You will also need to identify a proper workspace that provides adequate shelter and storage for your tools, filters, sand and gravel. The filtration sand should be covered or under a roof to keep it dry and from becoming contaminated. You may consider storing your tools and materials in a locked area to prevent looting.

The following tools and materials are needed to construct one concrete filter box:

Tools:

- Steel mold (Appendix 1)
- Utility knife
- Heat source if using polyethylene tubing (e.g. propane or kerosene torch, wood fire, electric burner)
- Wire brush, sandpaper, or steel wool to clean mold
- Level
- Wooden shims of various sizes
- Two 9/16" wrenches
- Containers for measuring sand, gravel and cement
- 1.5 m (5') metal rod (such as rebar) or piece of wood
- Rubber or wooden mallet
- Trowel
- Shovels
- Two 9/16" wrenches
- One 1-1/2" wrench
- Hammer
- 4 blocks of wood (about 5 cm square)
- Brush

Materials:

- 6 mm (1/4") ID and 9 mm (3/8") OD plastic tubing (polyethylene or vinyl)
- Tape (e.g. duct tape)
- Oil (edible product)
- Brush or rag to apply oil
- 12 litres of cement
- 24 litres of 1 mm (0.04") sand
- 12 litres of 12 mm (1/2") gravel
- 12 litres of 6 mm (1/4") gravel
- Water - approximately 7-10 litres
- Soap
- Face mask (optional)
- Gloves (optional)

The following tools and materials are needed for preparing the gravel and sand:

Tools:

- 12 mm (1/2") sieve
- 6 mm (1/4") sieve
- 1 mm (0.04") sieve
- 0.7 mm (0.03") sieve
- Shovels
- Wheelbarrow (if available)
- Several large containers approximately 40 cm (15") deep
- Small clear container with lid
- Several large containers approximately 40 cm (15") deep

Materials:

- Covers (e.g. tarps or plastic sheets), roof or building to keep the sand from getting wet and contaminated
- Clean water
- 12 mm (1/2") gravel
- 6 mm (1/4") gravel
- 0.7 mm (0.03") sand

See Appendix 2 for instructions on how to construct the sieves.

The following tools and materials are needed for building the metal diffuser box and lid:

Tools:

- Long straight edge or ruler (at least 120 cm (48"))
- Tape measure
- Square or right angle
- Marker
- Metal cutters suitable for 28 gauge galvanized steel
- Drill with 3 mm (1/8") drill bit
- Hammer
- Folding tool (e.g. bending brake) for bending 28 gauge sheet metal
- Anvil or steel plate set in a vice to hammer sheet metal against

Materials:

- 1 sheet of galvanized flat sheet metal (2438 mm x 1219 mm (4' x 8'), 28 gauge thick (0.46 mm or 0.018"))

Note: A single sheet makes 4 diffuser boxes (with some waste). For costing purposes; 3 sheets can make 15 boxes. No other materials are needed to construct the lid and diffuser box.

The following tools and materials are needed for installing one filter:

Tools:

- Tape measure
- A stick [approximately 100 cm (40") long, 2.5 cm x 5 cm (1" x 2") is preferred]
- Diffuser
- Storage container
- Watch
- Measuring container with 1 litre mark
- 1 m (3') of hose that just fits over the outlet tube
- Hose clamp (if available)
- Funnel (can be made from the top of a pop or water bottle)

Materials:

- Approximately 3 litres of washed 12 mm ($\frac{1}{2}$ ") gravel (drainage layer)
- Approximately 3 $\frac{1}{4}$ litres of washed 6 mm ($\frac{1}{4}$ ") gravel (separating layer)
- Approximately 25 litres of washed 0.7 mm (0.03") sand
- 40-80 litres (10-20 gallons) of water
- Chlorine

Stage B – Locate the Sand and Gravel

Selecting and preparing the filtration sand and gravel is crucial for the treatment efficiency of the biosand filter. While not complicated, the steps in preparing the filtration sand must be followed exactly as presented. Poor selection and preparation of the filtration sand could lead to poor performance and a considerable amount of work to rectify the problem.

Recommended Source

Crushed rock is the best type of filtration sand since it has less chance of being contaminated with pathogens or organic material. This sand also has less uniform sizing of the grains. A mixture of grain sizes is required for the proper functioning of the filter.

Gravel pits or quarries are the best place to obtain crushed rock, and are common in most parts of the world. You can also ask local construction, road work, or brick manufacturing companies to find out where they get their source of crushed rock.

At first, quarry rock may not seem proper for sieving due to the large amounts of dust. You can select the rock load and the crusher properly to ensure that large chunks of rock and dust are minimal. Often, you can even sieve the load at the quarry site and only pay for what you take. This greatly reduces waste and the cost.

Crushed rock may be difficult to locate, more expensive, and require transportation to your production site. However, it is critical in providing the best water quality and is worth the extra time, effort and cost.

Tip: CAWST is aware of crushed rock sources in many countries. If you have difficulties finding a local source, please contact CAWST and we may be able to connect you with a source already being used by other project implementers.

cawst@cawst.org

Other Sources

If crushed rock is absolutely not available, the next choice is sand from high on the banks of a river (that has not been in the water), followed by sand found in the riverbed itself. The last choice is beach sand.

River sand is usually contaminated with pathogens (from human and animal excreta) and contains organic material (e.g. leaves, sticks). Putting contaminated sand in the biosand filter may actually result in worse water quality than the original source water used. This happens because the organic matter is a food source for pathogens and helps them to grow and multiply in the filter until all of the food is consumed.

River sand needs to be disinfected and the organic material removed if it is going to be used as filtration sand. You can disinfect the sand by using chlorine or placing it in the sun. Disinfection will kill the pathogens; however it will not remove all of the organic material. This can only be done by heating the sand to very high temperatures to burn

off the organic material. This process is very costly, time consuming and not practical in most situations. For these reasons, it is better to spend your time and money to find a source of crushed rock that provides the best water quality.

Beach sand usually contains salt, organic material and other contaminants that will dissolve into the filtered water. You will need to flush the beach sand with fresh water to remove the salt. As well, you will need to disinfect the sand to kill the pathogens and then remove the organic material using a similar process as described previously for the river sand.

Table 2: Properties to Look for when Selecting the Filtration Sand

Should:	Should NOT:
<ul style="list-style-type: none"> • When you pick up a handful of the sand, you should be able to feel the coarseness of the grains. • You should be able to clearly see the individual grains, and the grains should be of different sizes and shapes. • When you squeeze a handful of dry sand, and then you open your hand, the sand should all pour smoothly out of your hand. • Sand with a lot of gravel, up to 12 mm (½”) in diameter, should be used. Using gravel larger than 12 mm (½”) is waste and will not be used in filter construction or as drainage gravel. 	<ul style="list-style-type: none"> • It should not contain any organic material (e.g. leaves, grass, sticks, loam, dirt). • It should not contain possible microbiological contamination. Avoid areas that have been used frequently by people or animals. • It should not be very fine sand or sand that is mostly silt and clay. • When you squeeze a handful of dry sand, it should not ball up in your hand or stick to your hand. If it does, it probably contains a lot of dirt or clay.



River sand is not recommended for use as filtration sand. However, river sand can be used to construct concrete filter boxes.

Stage C – Prepare the Sand and Gravel

SIEVE THE SAND AND GRAVEL

Tools:

- 12 mm ($\frac{1}{2}$ ") sieve
- 6 mm ($\frac{1}{4}$ ") sieve
- 1 mm (0.04") sieve
- 0.7 mm (0.03") sieve
- Shovels
- Wheelbarrow (if available)

Materials:

- Covers (e.g. tarps or plastic sheets), roof or building to keep the sand from getting wet and contaminated
- Face mask (optional)
- Gloves (optional)

Steps:

1. The sand must be passed through the 12 mm ($\frac{1}{2}$ ") sieve, the 6 mm ($\frac{1}{4}$ ") sieve, the 1 mm (0.04") sieve, and the 0.7 mm (0.03") sieve, in that order.
2. Discard the material that does not pass through the 12 mm ($\frac{1}{2}$ ") sieve.
3. Store the material that is captured by the 6 mm ($\frac{1}{4}$ ") sieve – this is used for your drainage gravel layer.
4. Store the material that is captured by the 1 mm (0.04") sieve – this is used for your separating gravel layer.
5. Store the material that is captured by the 0.7 mm (0.03") sieve – A portion of this material is used to make the concrete filter box while the other portion is sieved further to make the filtration sand.
6. The material that passes through the 0.7 mm (0.03") sieve is the filtration sand that goes into your filter. If constructing concrete filters, this sand should NOT be mixed with cement because it is too fine and will not produce good quality concrete.

Tips:

- When sieving, look under the sieve and watch the falling material. If very little or no material is falling out, then you can stop sieving that batch of sand or gravel.
- Any debris (e.g. wood, plastic, grass) found in the sand or gravel while sieving should be removed.
- Don't place too much sand or gravel on the sieves. Excess weight will cause the sieve to rip or break.

Tips:

- **Sieving sand is a lot easier if the sand is dry.** Wet or damp sand often plugs the screens making it difficult to sieve. If possible, leave the sand to dry in the sun beforehand. Then, store it under tarps or under a roof or in a building to protect it from moisture. During the dry season, you can prepare a large amount of sand and stockpile it under cover to prevent the sand from becoming wet.
- Wet sieving is a process which occurs when the sand is wet and can not, under any circumstances, be dried in the sun. It uses clean water to force the sand through the sieves.
- While sieving, ensure that you keep your piles tidy and separate so that they do not mix with each other or with unsieved sand. Poor sand quality due to stray rocks and mixing sieved sand sizes will reduce the treatment efficiency of the filter. If this happens, you will have to sieve the sand again.



Tidy and separate piles will keep the sand and gravel from mixing together

Filtration Sand and Gravel Sizes

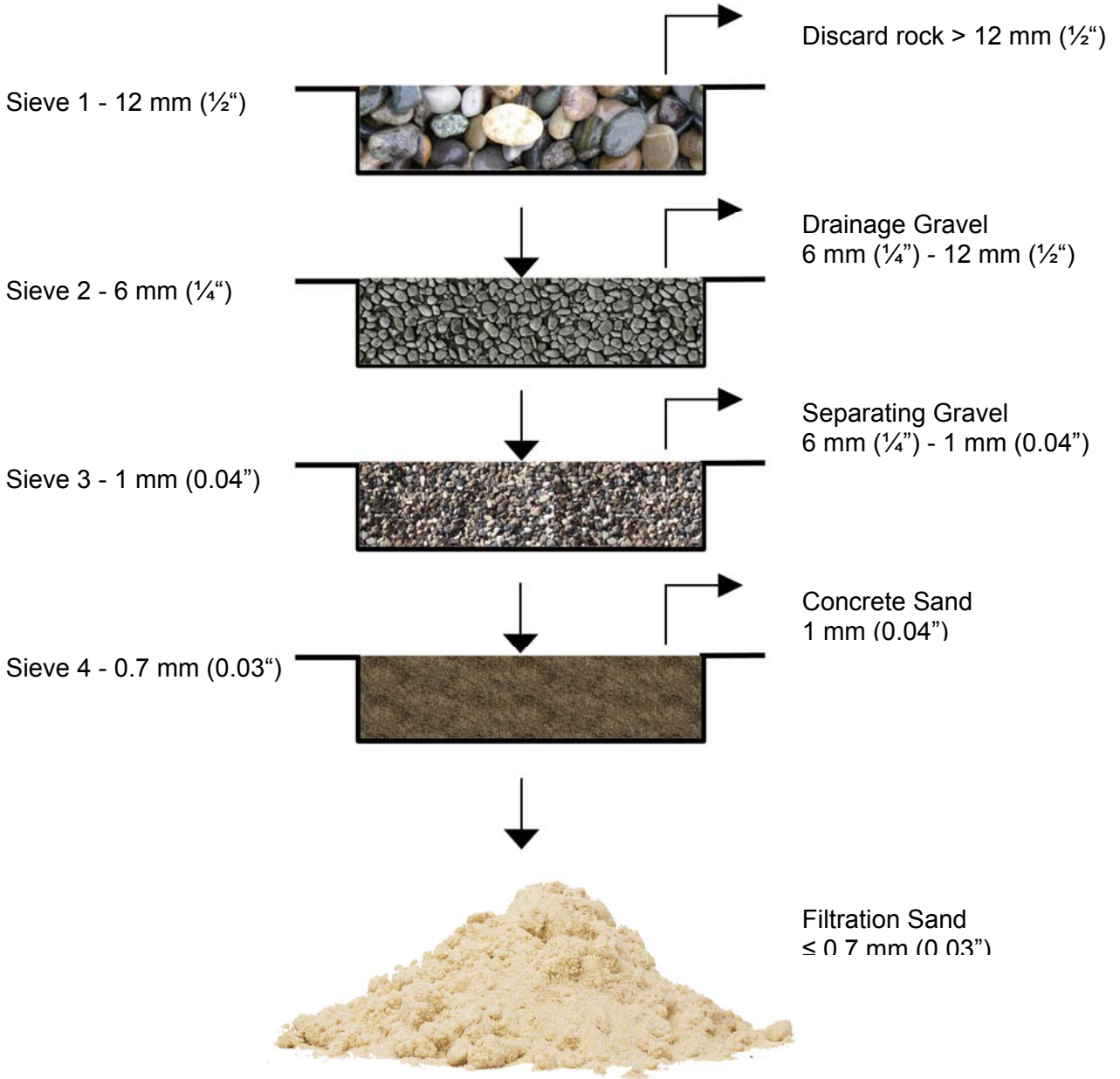

Filtration Sand
≤ 0.7 mm (0.03")



Concrete Sand
1 mm (0.04")



Separating Gravel
6 mm (1/4")



Drainage Gravel
12 mm (1/2")

WASH THE GRAVEL

Tools:

- Several large containers approximately 40 cm (15") deep

Materials:

- Clean water
- 12 mm ($\frac{1}{2}$ ") gravel
- 6 mm ($\frac{1}{4}$ ") gravel

Steps:

1. Place about 2-3 litres (0.5-1 gallon) of 12 mm ($\frac{1}{2}$ ") gravel in a container.
2. Put twice as much water in the container.
3. Using your hand, swirl the gravel around until the water becomes quite dirty.
4. Pour the dirty water out of the container.
5. Repeat the process until the water in your container is clear.
6. Wash the rest of the 12 mm ($\frac{1}{2}$ ") gravel, using the same method (a little at a time).
7. Repeat steps 1 to 6 for the 6 mm ($\frac{1}{4}$ ") gravel.
8. Place all of the gravel on a cover or concrete surface in the sun to dry. This step is especially important if the gravel or the wash water might be microbiologically contaminated.
9. Store the gravel under cover to keep it dry. You can also package it in bags or containers ready for use in the installation process (see Stage G Installation).



The separating and drainage gravel must be washed until the water in the container is clear

WASH THE FILTRATION SAND

Tools:

- Small clear container with lid
- Several large containers approximately 40 cm (15") deep

Materials:

- Clean water
- 0.7 mm (0.03") sand

1. Put a small amount of the 0.7 mm (0.03") sand in the container (approximately 10 cm (4") deep).
2. Put double the amount of water in the container.
3. Using your hand, swirl the sand around the container 10 times very quickly, making sure your fingers touch the bottom of the container and get all of the sand moving.
4. Quickly decant the dirty water.
5. Repeat steps 1 to 4 as many times as determined in the flow rate testing section.

Tip: Do NOT wash the sand until the water in your container is clean. This residual water should still be somewhat dirty. It takes time and practice to be able to know how much to wash the sand.

6. Wash the rest of the sand using the same method (steps 1 to 5).
7. Place all of the sand and gravel on a tarp or concrete surface in the sun to dry. This step is especially important if the sand, gravel, or the wash water might be biologically contaminated.
8. Store the sand under cover once it is dry. You can also package it in bags or containers to make it ready for transport and installation (see Stage G Installation).

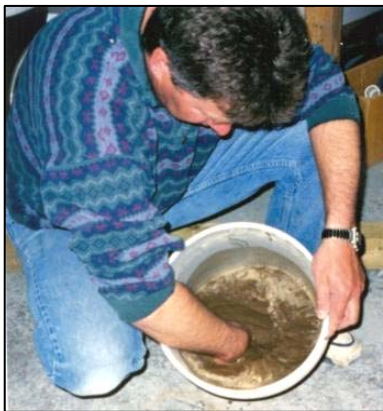

Unlike the gravel, the water in your container should not run clear. It will take practice to know how many times you will need to wash the sand.

JAR TEST

- The first time you wash the sand, it is necessary to experiment with the washing procedure in order to determine the proper number of washes.
- Wash the sand as described in steps 1 to 5 above. As you wash, count the number of times that you decant your container.
- Initially, it is a trial and error process – but that is why its important to count how many times you wash the sand, so that once you get the correct flow rate, you can repeat the same process. To **estimate** if the sand has been washed adequately, put some sand into a clear container with an equal amount of clear water. Put the lid on and swirl it. Looking from the side of the container, 3-4 seconds after you stop swirling, you should be able to see the surface of the sand.
- Your sand and gravel sources may vary so the number of times that you wash the sand will have to be adjusted periodically, but after some time you should develop the ability to know when the sand has been adequately washed, just by looking at the wash water in your container.



Not washed enough



About right



Washed too much

FLOW RATE TEST

- For the final test of the sand, install a biosand filter on site using your filtration sand and gravel, and test the flow rate. The flow rate should be 0.4 L/minute when the filter is installed.
- If the flow rate is much greater than 0.4 L/minute, the sand has been washed too much. You must decrease the number of times that you wash the sand. A flow rate that is too fast is not acceptable – the filter will not be effective.
- If the flow rate is much less than 0.4 L/minute, the sand hasn't been washed enough. You must increase the number of times that you wash the sand. The filter will still function if the flow rate is too slow, but it may plug more often, requiring more frequent maintenance. If the flow rate is just slightly less than 0.4 L/minute, it can be left as is – as long as the flow rate isn't so slow that it is inconvenient for the user.

Stage D – Construct the Filter Box

PLASTIC OUTLET TUBE

Tools:

- Utility knife
- Heat source if using polyethylene tubing (e.g. propane or kerosene torch, wood fire, electric burner)

Materials:

- 6 mm (1/4") ID and 9 mm (3/8") OD plastic tubing (polyethylene or vinyl)

Steps:

1. If the plastic tubing comes in a roll, straighten out the first section using a mild heat source as shown below.
2. Measure and cut off about 105 cm (41") length of plastic tubing.
3. If using polyethylene tubing, use a heat source to shape the tubing to approximate the dimensions shown above. A wooden jig may be useful.



If the polyethylene tubing is stiff, it may need to be heated in order to bend it



Often times, the vinyl is softer and will not need to be heated

Note: Do **NOT** use plastic tubing with less than 6 mm (1/4") inner diameter (ID). The inside area of the tubing with an ID of less than 6 mm (1/4") will not be sufficient to get a good flow rate. A low flow rate may also be due to the pipe crimping or a blockage in the pipe by the drainage gravel.

Do **NOT** use plastic tubing with an outer diameter (OD) of more than 9 mm (3/8"). The walls of the concrete filter body are not very thick and the tube may stick out of the concrete if the OD is too large.

PREPARE THE MOLD

Tools:

- Wire brush, sandpaper, or steel wool to clean mold
- Level
- Wooden shims of various sizes
- Two 9/16" wrenches

Materials:

- Tape (e.g. duct tape)
- Oil (edible product)
- Brush or rag to apply oil

Steps:

1. Clean the steel mold with the wire brush, sandpaper or steel wool to remove any attached concrete. Leave excess concrete on all joints as it will act as a seal.
2. Using oil, lightly cover all surfaces that will be in contact with the concrete. Do NOT oil the top of the interior mold since this is where you are going to tape the outlet tube.
3. Assemble the mold upside down by placing the 2 exterior parts of the mold on the interior mold. There should be a mark on the interior mold to indicate on which side the nose panel goes.
4. Insert and loosely hand tighten all bolts, ensuring that the upper edge of the mold is as square as possible.
5. Tighten all bolts with a wrench.
6. Tape the plastic tubing half way across the interior mold. Oil the top of the interior mold being careful that the tape still sticks.
7. Place the nose plate on the nose of the mold, with the plastic tubing sticking through the hole.
8. Tighten the set screw to hold the nose plate in place.
9. Secure the plastic tubing through the nose plate by taping it in place. Be careful to not pull the plastic tubing too tight or else you might cause a bend in the tube which will restrict the water flow. Place tape over the tube opening to protect it from getting plugged with concrete.
10. Use a level and wooden shims to make the mold level.



Tape the plastic tubing half way across the interior mold to prevent it from moving and filling with concrete



The nose plate should be secured tightly, with the plastic tubing sticking out through the hole

POUR THE FILTER

Tools:

- Containers for measuring sand, gravel and cement
- 1.5 m (5") metal rod (such as rebar) or piece of wood
- Rubber or wooden mallet
- Trowel
- Wooden shims of various sizes
- Shovel

Materials:

- 12 litres (3.2 gallons) of cement
- 24 litres (6.4 gallons) of 1 mm (0.04") sand
- 12 litres (3.2 gallons) of 12 mm (½") gravel
- 12 litres (3.2 gallons) of 6 mm (¼") gravel
- 7-10 litres (2-3 gallons) of water

Note: Be specific about the type of cement you use. You do **NOT** want to use pre-mixed cement with sand and gravel. Depending on the country, the following are different names of cement which are all the same product: Portland Cement, White Ordinary Portland Cement, General Use Cement, General Use Hydraulic Cement, Type 1 Cement, Type 10 Cement.

The cement should be fresh and not exposed to moisture. If there are lumps in the cement, it has probably been wet and should not be used. You can **NOT** break up the lumps and reuse the cement.

Steps:

1. Move the steel mold to the location where you want the filter to be poured. Remember that it will stay in this location for 6-24 hours while the concrete sets.
2. Measure 12 litres (3.2 gallons) of cement, 24 litres (6.4 gallons) of 1 mm (0.04") sand, 12 litres (3.2 gallons) of 12 mm (½") gravel, and 12 litres (3.2 gallons) of 6 mm (¼") gravel. Careful measuring ensures correct proportions.

Note: The following concrete mix ratio has been tested and proven to work.

1 part cement : 2 parts sand : 1 part 12 mm gravel : 1 part 6 mm gravel

For any batch size, the most important thing is to keep the proportions of the ingredients the same. You can double or triple the batch size simply by doubling or tripling the number of containers of each ingredient you add to the mix.

3. Place the materials in layers on top of each other on a clean, flat surface, beginning with the gravel, then the sand, and finally the cement.

- Mix dry ingredients together using a shovel. Make a shallow hole in the centre of the dry mix using your shovel. Pour about 4 litres (1 gallon) of water into the hole and mix it thoroughly with the dry ingredients. Mix thoroughly by pulling dry material from the edges into the water.
- When you have finished mixing, repeat Step 5 and continue to add water (about 7-10 litres (2-3 gallons) in total depending on the dampness of the sand) until the mix reaches the proper consistency - fairly stiff and dry.

Tip: You can always add more water to the concrete mix, but you cannot take it away. The less water used, the stronger the dried concrete will be. The filter body is prone to cracks or leaks if too much water is added.

- Test the mix. You can tell if the concrete has too little or too much water by using the blade of your shovel to make ridges in the concrete. If the mix is too dry, you won't be able to make distinct ridges; if the mix has too much water, the ridges won't hold their shape and you may notice water seeping out around the edges of the pile. In a proper mix, the ridges will hold most of their shape.



Mix the dry ingredients together using a shovel. Make a shallow hole in the centre and pour water into the hole. Mix thoroughly and continue to add water until it reaches the proper consistency.



The consistency of the concrete should be fairly stiff and dry. The filter is prone to cracks or leaks if too much water is added.

- Place the concrete into the mold using a shovel or container.
- As each layer of concrete is added to the mold, work it with the metal rod to ensure the concrete completely fills the area without any voids. At the current level of the concrete, hit the outside of the mold on all sides, including the nose, with the mallet in an upward pattern. The vibration allows air pockets to escape the concrete.

Tip: To determine if the nose is full of concrete, hit it with the mallet. Water will seep out when the nose is full of concrete. Be sure to hit the nose several times with the mallet to make sure that there are no air bubbles that may cause cracks or breaks.

Biosand Filter Manual

9. As you fill the last of the mold, check the nose plate and plastic tubing to ensure that they have not moved.
10. Jab your trowel at least 10 cm (4") into the concrete, all around the inner mold, to ensure that the final layer mixes with the previous layer. This will also allow for the concrete to settle down the sides more.
11. Pile a shovel full of concrete on the top and allow it to settle for 30-45 minutes.
12. Repeat Step 8 to help prevent cracking around the base of the filter. Smooth away the excess concrete and then use a trowel to make a flat surface. This will be the bottom of the filter.
13. In hot climates, you may need to cover the concrete with a wet cloth and a plastic sheet to keep the concrete from drying too quickly. Keep the cloth wet as it dries throughout the day.



Step 7 - Fill the mold full of concrete



Step 8 - Use a metal rod to help the air escape



Step 8 - Vibrate the mold with a rubber mallet to help the air escape

REMOVE FILTER FROM MOLD

Tools:

- Two 9/16" wrenches
- One 1-1/2" wrench
- Hammer
- 4 blocks of wood (about 5 cm square)
- Brush

Materials:

- Soap

Steps:

1. Wait until the concrete has set. This may take anywhere from 6 to 24 hours depending on the consistency of the concrete mix that you used and the local climate.
2. Loosen the set screw and remove the nose plate.
3. Turn the mold completely upside down (180°), using a tire or a sack of grain to support its weight as you go.
4. Remove the bolts on top of the mold. Do not loosen any of the side bolts yet.
5. Hit the top of the mold with a mallet (or use a block of wood and a hammer), to loosen the bond with the concrete.
6. Position the extractor on top of the mold. Each leg of the extractor should sit in the corresponding slot on the inner mold.
7. Tighten the centre bolt (by turning the bolt clockwise) until the bolt is well threaded into the nut on the mold.
8. Tighten the nut (which sits above the square tubing) by turning it clockwise. Turn the nut down until it contacts the square tubing and then continue turning, which pulls upward on the interior mold until it releases.
9. Continue turning the centre nut until the interior mold is entirely released.

Note: If the mold starts to bend, stop what you're doing immediately.

Check that the nuts and bolts on the inner mold have been removed. If the inner mold is still stuck, undo all nuts and bolts, remove the exterior panels and break the concrete off of the interior mold. **Do not damage the mold for just one filter.**



Step 6



Step 8 – Tightening the nut on the extractor to remove the interior mold

between the

exterior mold and the interior mold.

11. Loosen the centre nut on the extractor assembly until the interior mold rests on the wooden spacers.
12. Remove the extractor.
13. Carefully remove the interior mold and place it in a safe location.
14. Remove the remaining bolts and the 3-sided panel.
15. Remove the front (nose) panel.

Tip: You may need to tip the filter back and place a wooden shim under the front edge, and then use a hammer and small pry bars to detach the front panel.

16. Clean and oil the mold.
17. Remove the tape that covers the outlet tubing in the interior of the filter. Remove the tape on the other end.
18. Check the two ends of the outlet tubing to ensure they are not plugged by concrete. Remove any visible debris until you can clearly see or feel the outlet at the bottom of the filter.
19. Fill the filter with water. The flow rate should be approximately 1 litre/minute. Determine water level within the filter once the water stops coming out of the tube.
20. If the water level is above the diffuser, cut the outlet tube a small amount and repeat steps 18 and 19 until water level is below the diffuser.

Note: The water level in the filter is determined by the end of the outlet tube. Due to a siphoning effect, the water will stop flowing when the standing water is at the same level as the end of the outlet tube.

21. Check for cracks and flaws in the filter.
22. Plug the outlet and completely fill the filter with water. Keep it full for five to seven days while the concrete cures. Do not move or disturb the filter during that time.
23. After the concrete has cured, put a small amount of soap in the water that was sitting in the filter, and scrub the inside of the filter out with a brush. Rinse with clean water.
24. Store the filter until it is ready to be transported and installed. Ensure stored filters are covered or tipped over after the concrete has cured to prevent them from getting dirty and becoming a breeding ground for insect vectors.
25. Optional – The outside of the filters can be painted to improve its attractiveness for the users. It usually takes one coat of primer and one coat of water-based paint.

Stage E – Construct the Diffuser

The purpose of the diffuser is to prevent any disturbance of the sand surface and biolayer when water is added to the top of the filter. It is essential for the correct operation of the filter so that pathogens do not penetrate far into the sand bed.

There are several types of diffusers that can be built – each with its own advantages and limitations. The one that you choose to build will depend on your skill level, the tools and materials that are available, and the preference of the user.

Design Specifications:

- 3 mm (1/8”) diameter holes in a 2.5 cm x 2.5 cm (1” x 1”) grid pattern. Larger holes will result in disturbance of the surface of the sand. Smaller holes will restrict the flow through the filter, possibly causing the flow rate to drop
- There should not be a gap between the edge of the diffuser and the concrete filter. A gap allows water to travel along the walls of the filter, rather than being distributed evenly through the holes of the diffuser plate.
- A tight fit will also prevent a diffuser made of light material from floating.

Tips:

- Many materials have been used for the diffusers – sheet metal, plastic, and concrete. Galvanized sheet metal is recommended since it is more durable and lasts longer. If poorly galvanized sheet metal is used, it will rust quickly and eventually need to be replaced. Avoid using any material that will rot or cause the growth of mold or algae in the presence of water (e.g. wood).
- The metal diffuser box design is recommended since it does not let water to travel down the walls of the filter. This type of diffuser is needed for the arsenic version of the filter or to retrofit previous versions of the filter to the Version 10 design. If you choose to construct the metal diffuser box, it is also recommended that you also construct the lid with galvanized sheet metal. This lid will fit nicely over the entire filter, including the metal flaps of the diffuser box that will hang off the top edge of the filter.

OPTION 1 - METAL BOX DIFFUSER AND LID

Tools:

- Long straight edge or ruler (120 cm/48" or longer)
- Tape measure
- Square or right angle
- Marker
- Metal cutters suitable for 28 gauge galvanized sheet metal
- Drill with 3 mm (1/8") drill bit
- Hammer
- Folding tool (e.g. bending brake)
- Anvil or steel plate set in a vice to hammer sheet metal against

Materials:

- 1 sheet of galvanized sheet metal 2438 mm x 1219 mm (4' x 8'), 28 gauge thick (0.46 mm or 0.018")

Note: Caution! Be careful of sharp edges and wear hand protection if needed.

Steps:

1. Lay out the sheet metal and mark lines for cutting the outline of each piece according to the dimensions shown on Figure 1.
2. Cut out the side walls, bottoms, lids and corner pieces.
3. Measure and mark cut lines (solid line) and fold lines (dashed) for each piece according to dimensions provided in:
 - i. Figures 2 & 3: Filter lid
 - ii. Figure 4 & 5: Side walls and corner pieces
 - iii. Figure 6 & 7: Bottom piece
4. Cut along solid lines and fold along dashed lines as shown in the folding sequence provided in each Figure.

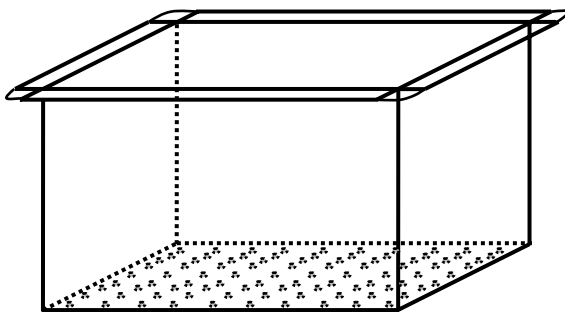

Diffuser Box

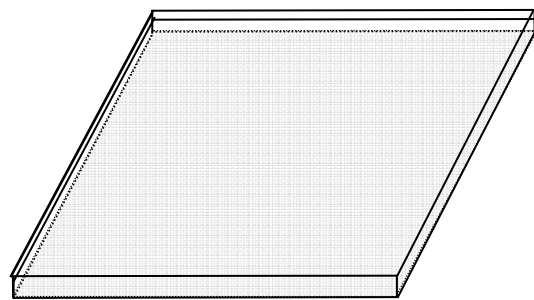

Filter Lid

Figure 1

Layout for cutting sheet metal for 4 diffuser boxes

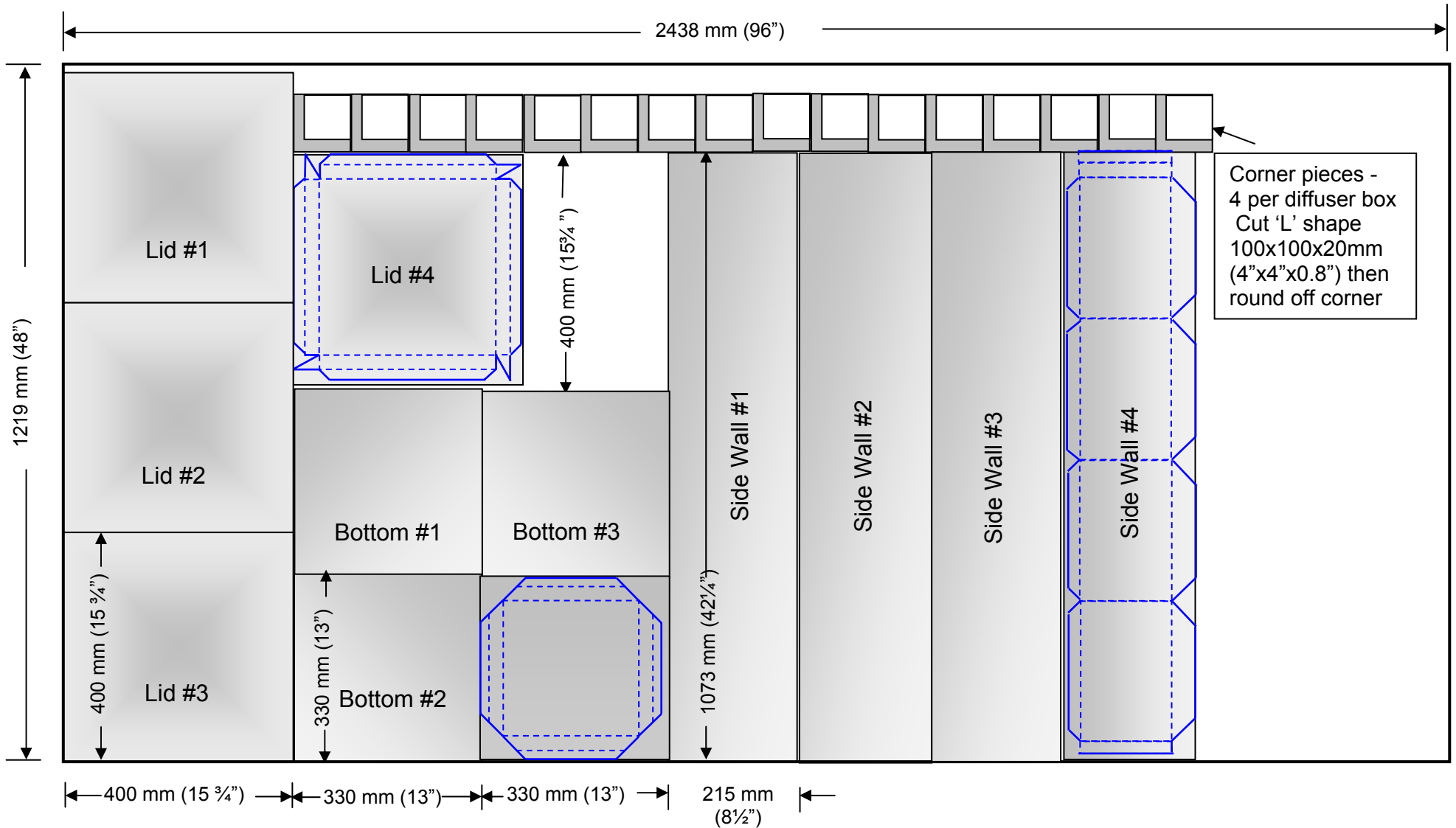
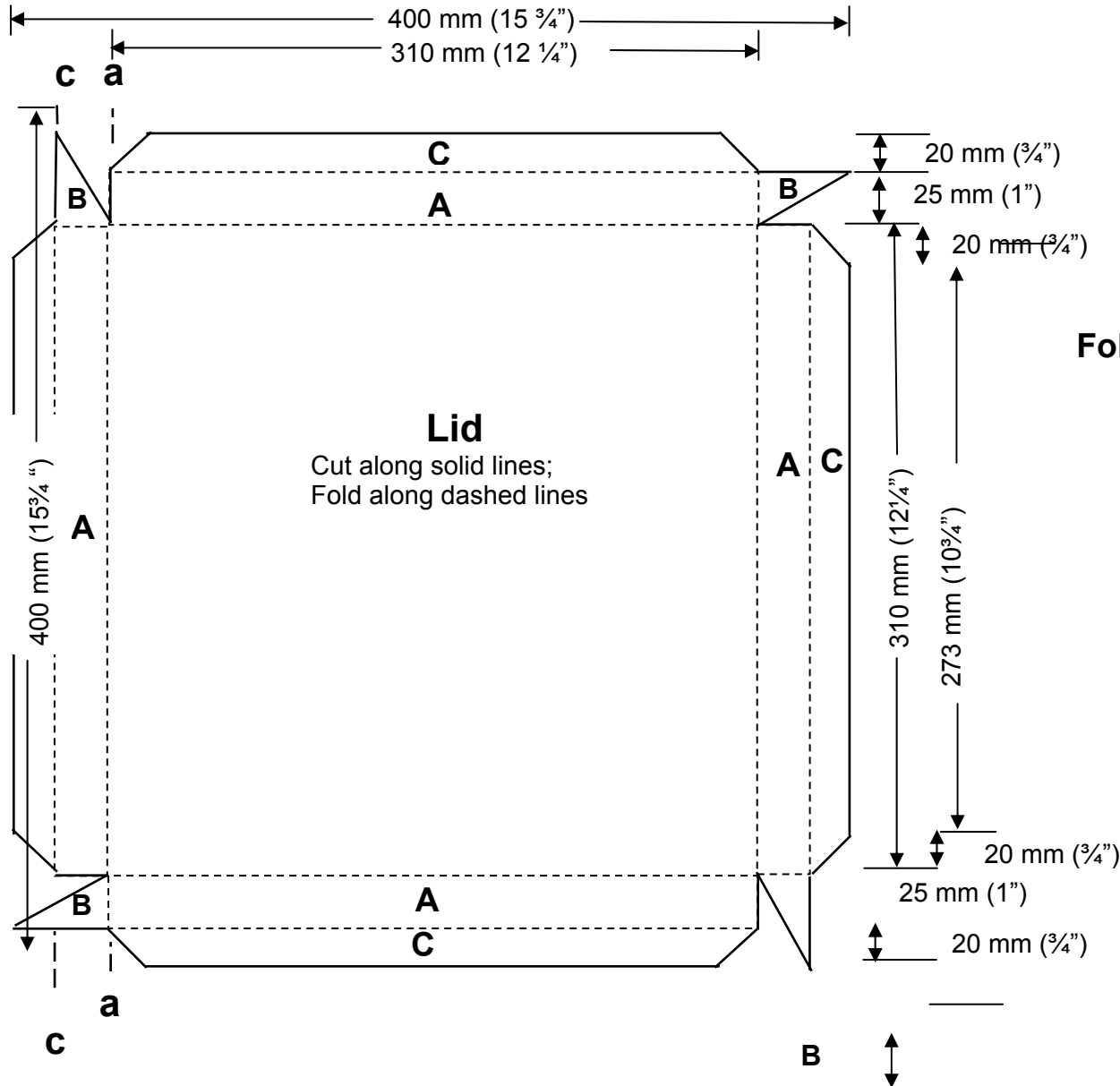

Figure 2
Filter Lid



Folding Sequence for Lid:

1. Fold four **A** flanges down along bend line **a - a**.
2. Fold flaps **B** 90° inward so they lie alongside (parallel to) flange **A**.
3. Fold flange **C** upwards along **c - c** and press to lock flaps **B** in place.

Figure 3
Folding Detail for Filter Lid

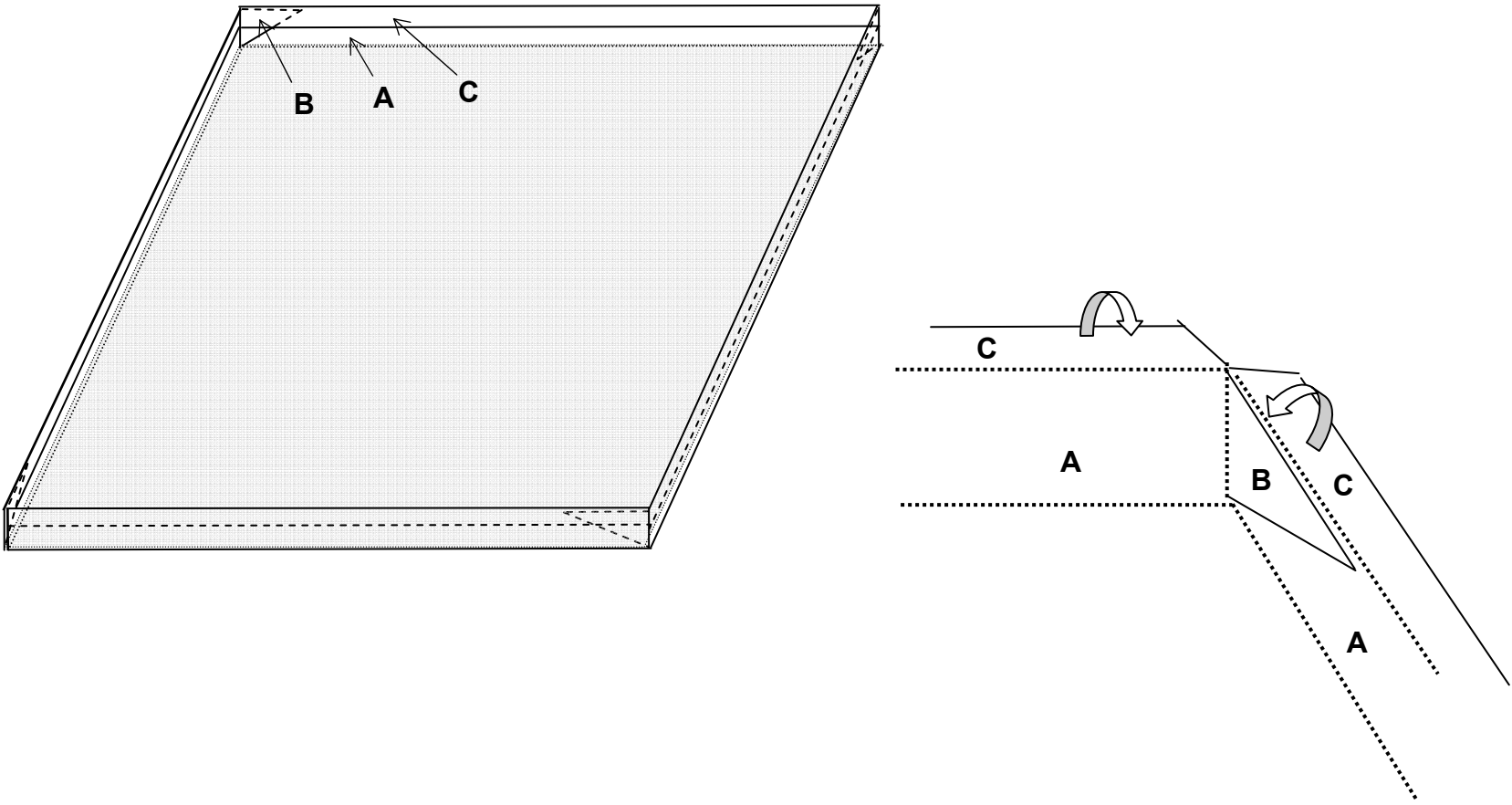
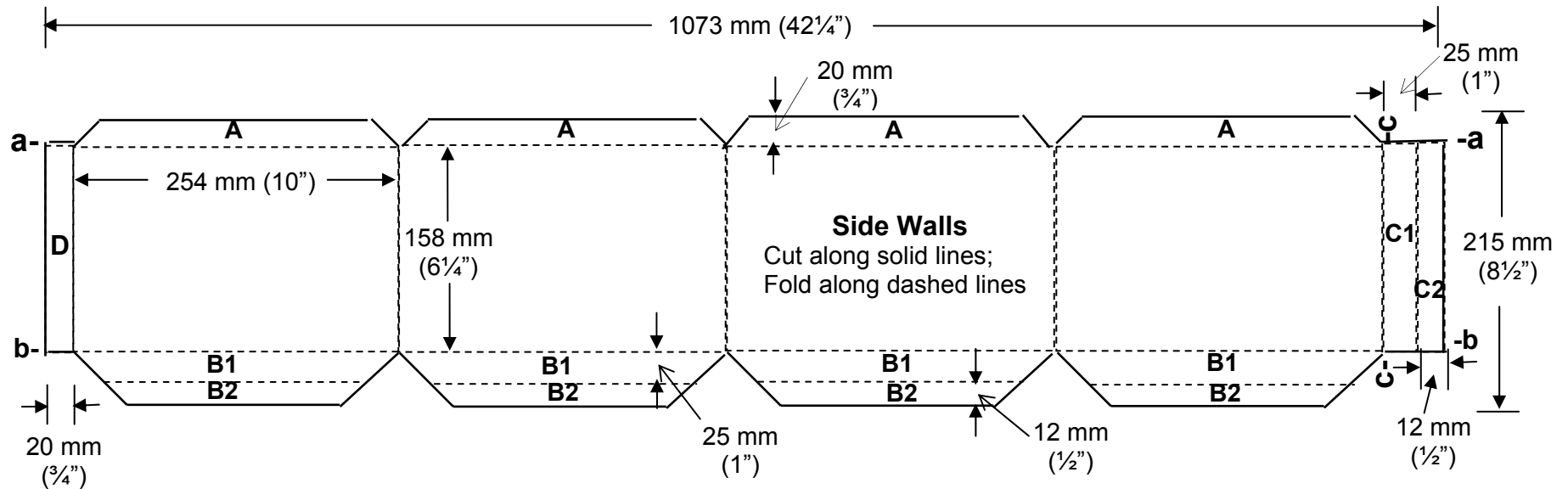

Figure 4

Side Walls and Corner Pieces



Folding Sequence for Side Walls

1. Fold flanges **A** to 90° along bend line **a-a**. These flanges will be on the outside of the box and attach to the Bottom Piece.
2. Fold flange **B** (tabs **B1** and **B2**) down 90° along **b-b**
3. Fold **B2** (outer tab of flange **B**) to 90°. This **B** flange will form a lip around the outside of the box. This lip will sit on the top of the walls of the filter to suspend the box in the filter. Tab **B2** will be on the underside of the lip of the box.
4. Fold **C2** (outer tab of flange **C**) to 90°. This flange will be on the outside of the box.
5. Fold flange **D** to 90°. This flange will be on the outside of the box.
6. Fold the box into a square and then fold the locking seam, first folding the outer tab **C2** tightly over flange **D**, then folding along line **c-c**
7. Lay in 2 corner pieces and then finish folding one flange **B** pressing it to lock the corner pieces in place. Work around the rim inserting corners, folding the remaining **B** flanges.

Corner Pieces

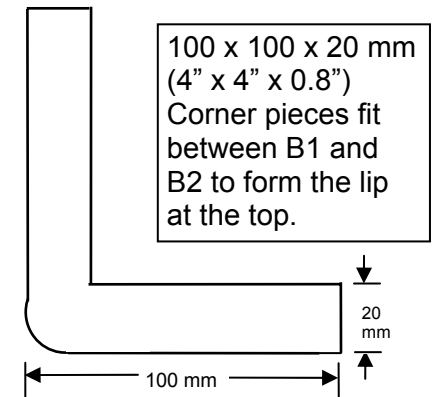

Figure 5
Folding Detail for Side Wall Piece

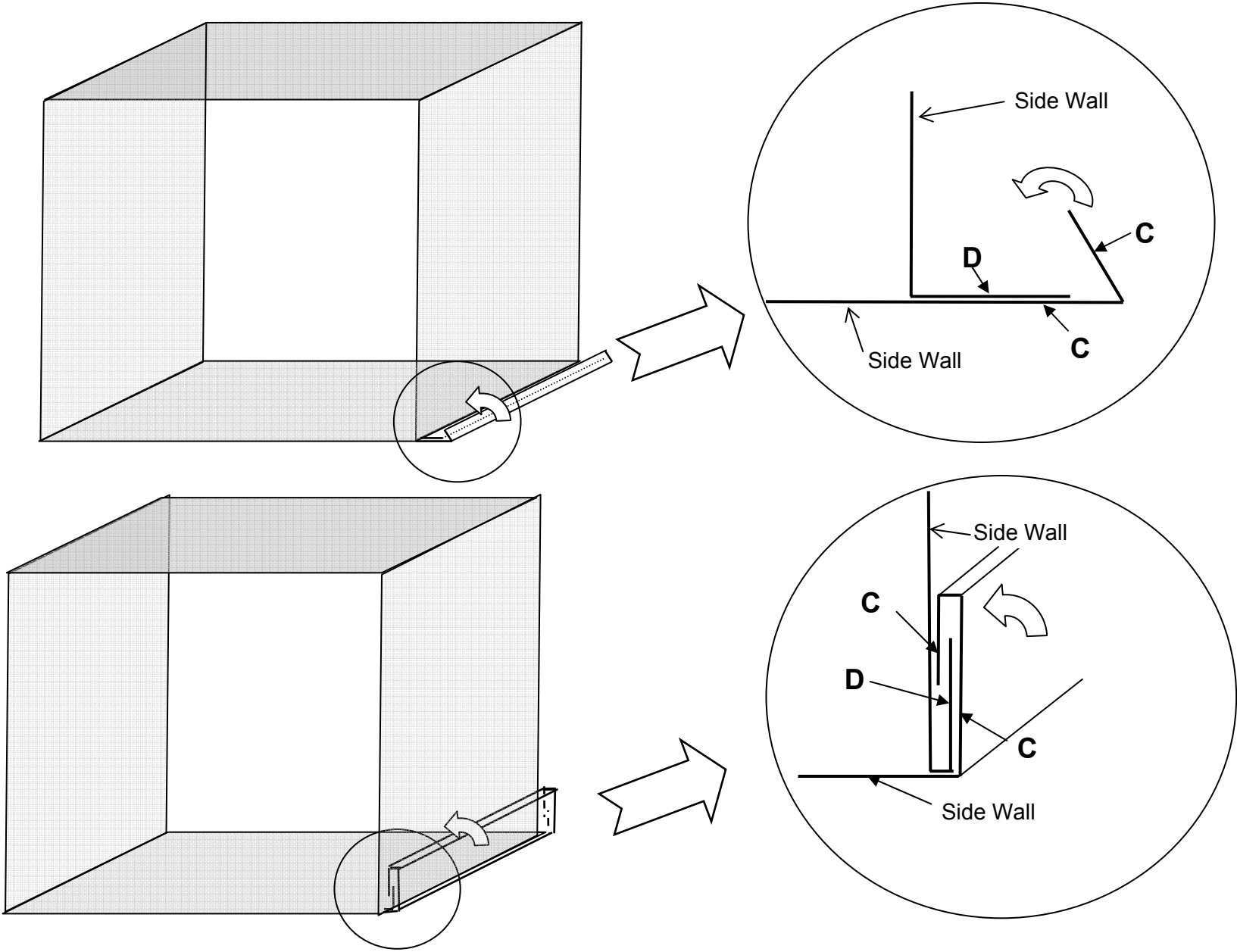
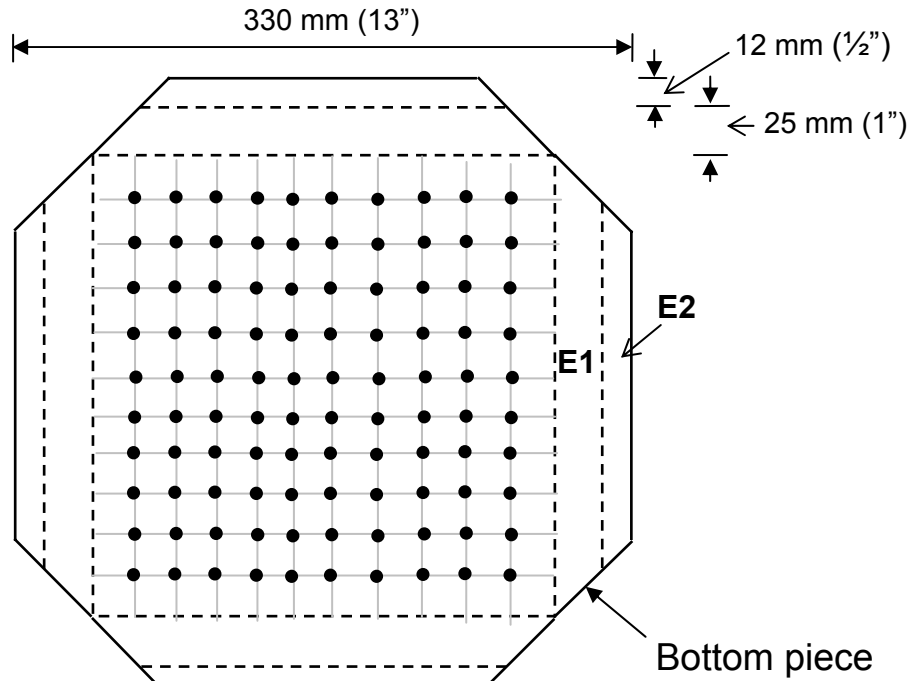

Figure 6

Bottom Piece



Folding Sequence for Bottom Piece

1. Punch or drill holes in the Bottom Piece
 - holes to be 3 mm (1/8") in diameter
 - space holes 2.5 cm (1") apart
 - make 80 to 100 holes
2. Fold E2 (outer tab of flange E) to 90°
3. Set the box (bold outline below) on the base and fold flanges E2 tightly over flanges A on the bottom sides of the box.
4. Fold up flange E against the outside of the box.

See also Figure 7 – Folding Detail for Bottom Piece

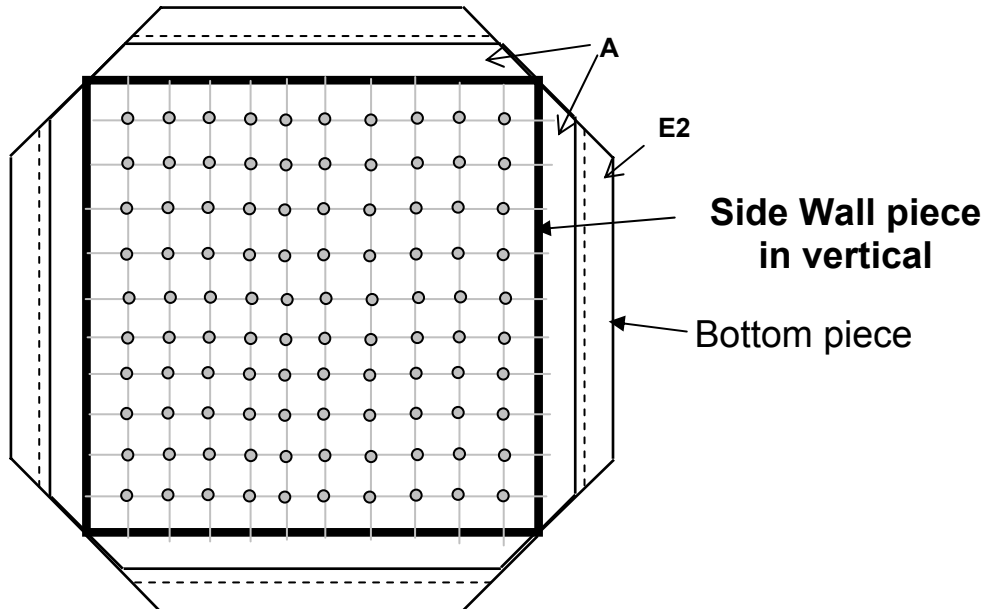
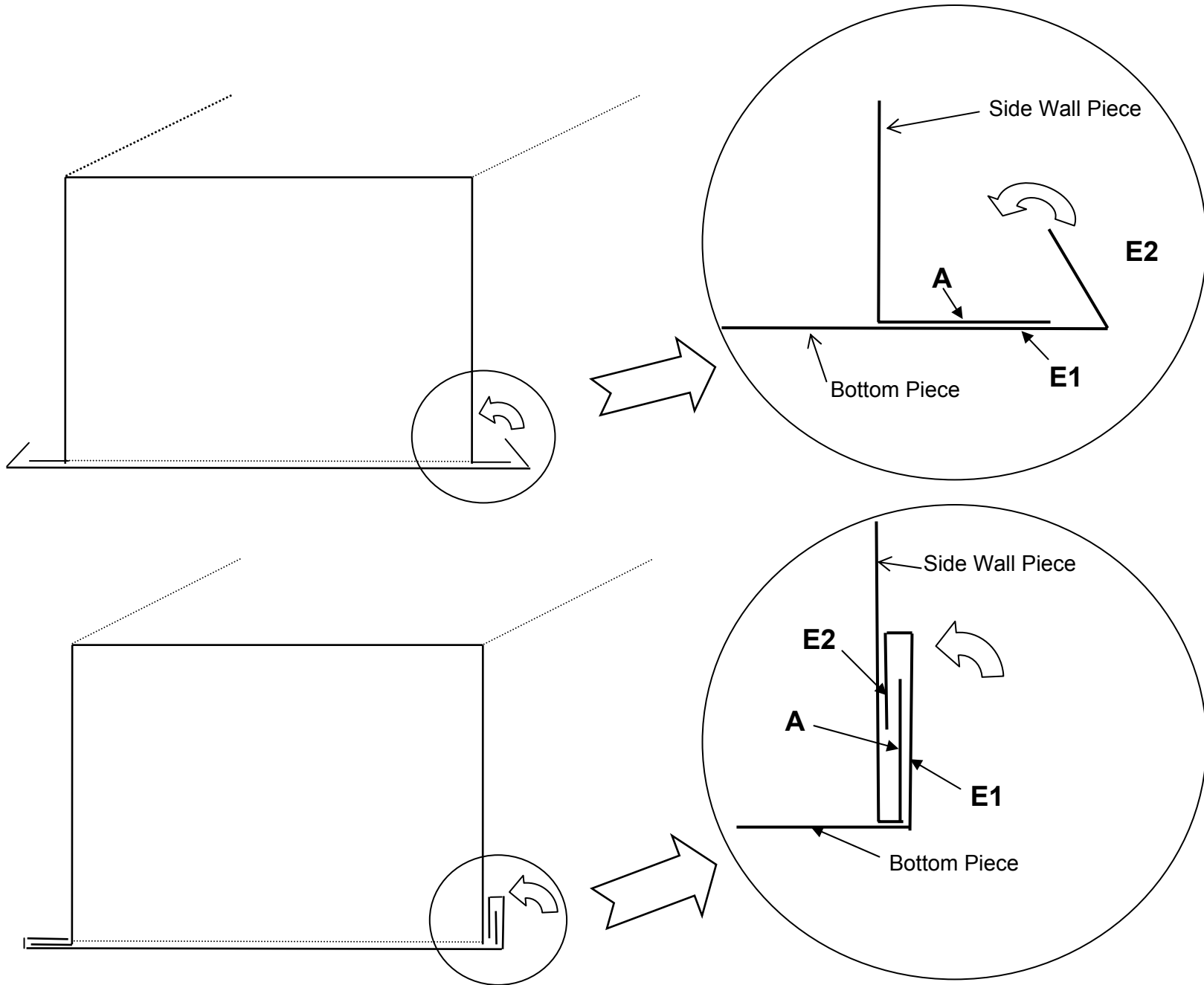

Figure 7
Folding Detail for Bottom Piece



OPTION 2 - SIMPLE METAL DIFFUSER

Tools:

- Tape measure
- Tin snips
- Leather gloves
- Hammer
- Marker
- 3 mm (1/8") diameter nails

Materials:

- 30 gauge galvanized sheet metal (or nearest available size)

Steps:

1. Measure the inside reservoir of the filter at the height of the ledge where the diffuser will sit. If the filter is not perfectly square, you may need to measure the width in both directions.
2. Cut a piece of sheet metal that is 10 cm (4") wider than the reservoir (in both directions).
3. Measure and mark a line 5 cm (2") from the edge of each side.
4. Measure and mark a 2.5 cm x 2.5 cm (1" x 1") grid on the sheet metal, inside the square which is formed by the lines from Step 3.
5. At each intersection on the grid, pound a 3 mm (1/8") diameter hole through the sheet metal, using a hammer and a 3 mm (1/8") diameter nail.

Tip: A jig can be constructed out of wood with nail tips in a 2.5 cm x 2.5 cm (1"x1") grid, facing up out of the wood so that the sheet metal can be pounded onto the jig, forming all of the holes in one step.

6. Make a handle so that the diffuser can be easily pulled out, once in place. Handles can be made from a piece of nylon string or wire tied through holes in the diffuser plate, or a bent nail.



Drawing a grid will help with the nail-hole placement



This is an example of a bad diffuser. It has too many holes - only 100 holes are needed.

OPTION 3 - CORRUGATED PLASTIC DIFFUSER

Tools:

- Tape measure
- Utility knife
- Hammer
- Marker
- 3 mm (1/8") diameter nails

Materials:

- Corrugated plastic sheet (looks like cardboard, but made from plastic)
- Nylon string or nail

Steps:

1. Measure the inside of the reservoir at the height of the ledge where the diffuser will sit. If the filter is not perfectly square, you may need to measure the width in both directions.
2. Cut a piece of plastic the same size as the reservoir.

Tip: Cutting plastic so that it fits snugly in the reservoir will prevent the diffuser from floating when water is poured into the filter. A rock or other weight can also be placed on the diffuser to stop it from floating.

3. Measure and mark a 2.5 cm x 2.5 cm (1" x 1") grid on the plastic.
4. At each intersection on the grid, push a nail with a 3 mm (1/8") diameter through the plastic and then remove it (to create the holes).
5. Make a handle so that the diffuser can be easily pulled out, once in place. Handles can be made from a piece of nylon string or wire tied through holes in the diffuser plate, or a bent nail.



A corrugated plastic diffuser with well placed holes

OPTION 4 - PLASTIC PLATE DIFFUSER

Tools:

- Tape measure
- Electric saw or acrylic cutting knife
- Electric drill
- Marker
- 3 mm (1/8") diameter nails

Materials:

- Clear acrylic plastic or stiff polyethylene plastic
- Nylon string or nail

Steps:

1. Measure the inside of the reservoir at the height of the ledge where the diffuser will sit. If the filter is not perfectly square, you may need to measure the width in both directions.
2. With a saw or using an acrylic cutting knife, cut a piece of plastic the same size as the reservoir.
3. Measure and mark a 2.5 cm x 2.5 cm (1" x 1") grid on the plastic.
4. At each intersection on the grid, drill a 3 mm (1/8") diameter hole through the plastic.
5. Make a handle so that the diffuser can be easily pulled out, once in place. Handles can be made from a piece of nylon string or wire tied through holes in the diffuser plate, or a bent nail.

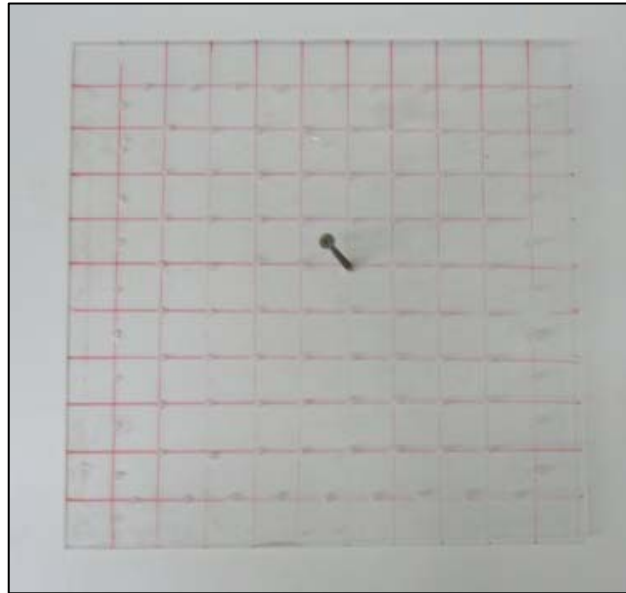

An acrylic plastic diffuser with well placed holes

Stage F – Construct the Lid

The purpose of the lid is to prevent contamination of the water and the sand. It is essential to the correct operation of the filter. There are several types of lids that can be built. The one that you choose to build will depend on your skill level, the tools and materials that are available, and the preference of the user.

Several materials have been used for the lids, including wood, solid-wood carvings, plastic, ceramic tiles, and sheet metal. The appearance of the lid should be taken into consideration since it shows at all times and will be inside the user's home.

Design Specifications:

- Should completely cover the filter reservoir
- Made so that the lid cannot be easily knocked off the filter
- Easy to remove and put on the filter

OPTION – SIMPLE WOODEN LID

Tools:

- Hammer
- Tape measure
- Saw

Materials:

- 2.5 cm x 10 cm (1" x 4") lumber (or whatever is locally available)
- Nails or screws

Steps:

1. Measure the outside width of the concrete filter at the top. If the filter is not perfectly square, you may need to measure the width in both directions.
2. Cut pieces of wood sufficient to cover the entire top of the filter. These pieces will form the lid itself.
3. Place these pieces in the shape of the lid, with the underside facing up.
4. Measure the top inside of the filter reservoir. If the filter is not perfectly square, you may need to measure the width in both directions.
5. Mark the size and position of the opening on the pieces of your lid (from Step 3). Cut two pieces of wood the length of the opening of the filter.
6. Place those two pieces of wood perpendicular to the other pieces, on top of the others.
7. Centre those two pieces of wood so that in both directions, they line up with the opening of the filter that you marked in Step 5. (Those two pieces will sit inside the opening on the filter and will stop the lid from moving in either direction.)
8. Nail each of the two pieces onto all of the other pieces.
9. Flip your lid over and ensure that it fits on the filter. (The two pieces from Step 6 should just fit inside the filter, and the other pieces should cover the entire top edge of the filter.)

10. Attach a handle. This handle is optional as the top of the filter can be used as storage if the handle is not attached (see photo below). If no handle is attached, the filter lid will still be easy to remove.



Top of a wooden lid



Under side of a wooden lid

Tip: Nails straight through the lid into the handle don't hold the handle on very well. Use at least two nails at different angles or a screw.



If no handle is placed in the lid, the top of the filter can be used for storing other household items

Stage G – Installation

The biosand filter must be installed correctly for it to work properly. Make a checklist and use it to ensure that you have everything you'll need before you head out to install a filter. An example of an installation checklist is provided in Appendix 4.

TRANSPORT THE FILTER

Always consider the safety issues related to moving the filter. There can be injuries due to strains of the back, arms, and knees. Be careful to not crush or pinch your fingers and toes under or behind the filter. Keep in mind the size of the filter 30 cm x 30 cm x 90 cm (12" x 12" x 36") and its weight [95 kg (210 lbs) plus an additional 45 kg (100 lbs) of sand]. It can be difficult and awkward to move this large object.

Some ways to move the filter include:

- Cart – animal or human powered
- Car, truck, or boat
- Carrying slings – wide, heavy canvas straps placed over the shoulder to lift a heavy object
- Dolly – a frame or rack with small wheels, strong enough to carry the weight
- Rollers – metal or wooden, round pieces that can be used to move the filter short distances.



Transporting filters with a specially constructed dolly



Transporting filters by horsepower



Carrying filters using wood supports



Loading filters in the back of a truck

POSITION THE FILTER

It is important to determine a good location for the filter. Locating the filter inside the home is important not only for filter effectiveness, but also for the convenience of the user. If the users can access the filter easily, they will be more likely to use and maintain it. Once filled with sand, the filter should not be moved.

The filter should be placed:

- In a protected location away from sunlight, wind, rain, animals, and children
- Preferably inside the home on level ground
- Near the food preparation or kitchen area (depending on the space and layout of the home)
- Where it will be used and maintained easily
- So that water can easily be poured in the top
- Where there's adequate room for hauling and pouring pails of water into the filter, as well as storing the filtered water

Tip: If the users are short, you may have to add a step so that they don't have to lift the container of source water above their shoulder height.



Positioning the filter inside the household cooking area

PLACE THE SAND

Tools:

- Tape measure
- A stick [approximately 100 cm (40") long, 2.5 cm x 5 cm (1" x 2") is preferred]

Materials:

- Approximately 3 litres of washed 12 mm ($\frac{1}{2}$ ") gravel (drainage layer)
- Approximately 3¼ litres of washed 6 mm ($\frac{1}{4}$ ") gravel (separating layer)
- Approximately 30 litres of washed 0.7 mm (0.03") sand
- At least 2 containers of water

Tip: The exact quantity of gravel and sand can be determined once using the following steps. Then you can pre-measure and package the sand and gravel in separate bags before delivery.

Steps:

1. Ensure that the outlet tube at the bottom inside of the filter is clear and unobstructed (i.e. not covered by concrete or plugged by debris.) The flow rate through the tubing without any sand in the filter should be about 1 litre/minute. After the flow has stopped, the water level should be slightly below the diffuser.

Note: This step should have been done when the filter was removed from the mold, however, double check now before you get too far into the installation.

2. Ensure that the inside of the filter has been cleaned out (including dirt, dust, and oil from the mold).
3. Place a stick inside the filter so that it's touching the bottom of the filter.
4. Draw a horizontal line on the stick where it meets the top edge of the filter.
5. Measure and mark a line 5 cm (2") down from the first line.
6. Fill the filter half full of water.

Note: The sand must always be added with water already in the filter to prevent pockets of air from being trapped within the sand.

7. Add approximately 5 cm (2") of 12 mm ($\frac{1}{2}$ ") gravel to the filter. This is the drainage layer.
8. Level out the gravel, and use the stick to measure how much has been added. Place the bottom of the stick on the gravel. When the 2nd line on the stick lines up with the top edge of the filter, you have added enough gravel.

Note: Ensure that the gravel covers the drain hole near the bottom of the filter.

9. Measure and mark a third line 5 cm (2") down from the second line.
10. Add approximately 5 cm (2") of 6 mm (¼") gravel to the filter. This is the separating layer.
11. Level out the gravel and use the stick to measure how much has been added. Again, place the bottom of the stick on the gravel. When the 3rd line on the stick lines up with the top edge of the filter, you have added enough gravel.
12. Quickly pour approximately 30 litres of washed sand to the filter (ensuring that there is always water above the surface of the sand).

Note: It is important the sand is added in water. This prevents air pockets from forming in the sand layer. A random distribution of different sand grain sizes is also critical to the proper operation of the filter. Adding the sand quickly maintains the random distribution by not allowing the different sizes of grains to settle into layers.

13. Fill the filter with water and let it run until water stops pouring out of the outlet tube. When this happens the water level is equalized.
14. Smooth out the sand and then measure the depth of the water above the sand bed.
15. **If the water depth is less than 3 cm (1.2"):** remove sand until the depth is 5 cm (2") (with the sand surface level and the water level equalized).
16. **If the water depth is more than 5 cm (2"):** add more sand and then repeat steps 13 to 17. Continue until the water depth is 5 cm (2").
17. Swirl the top layer of sand and dump out the muddy water to prevent the sand from plugging.
18. Smooth out the surface of the sand so that it's as level as possible.

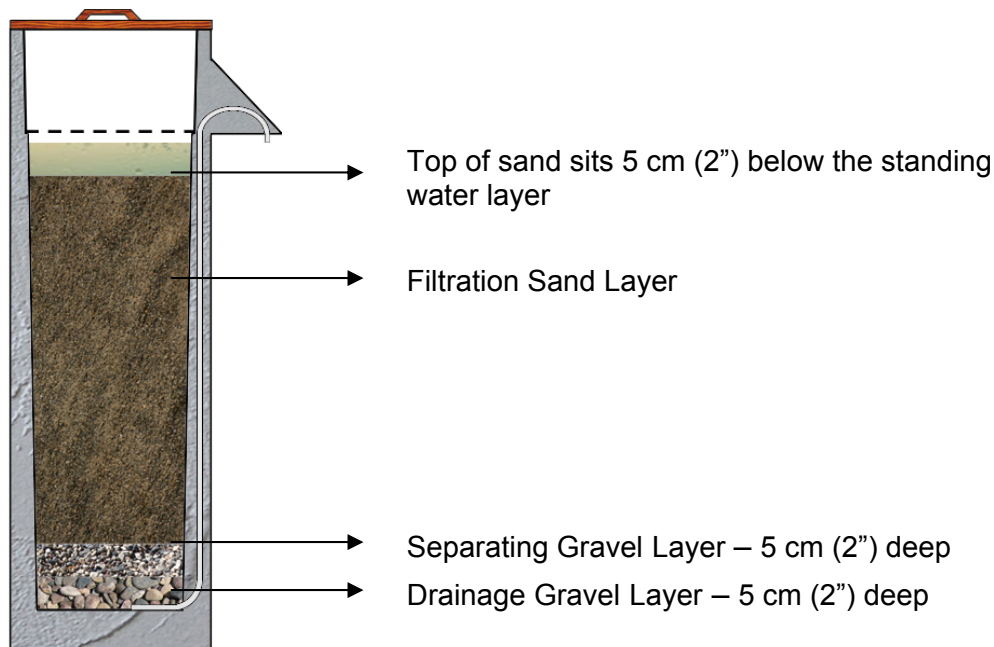

FLUSH THE FILTER

Tools:

- Diffuser
- Storage container

Materials:

- 40-80 litres (10-20 gallons) of water

Steps:

1. Place the diffuser inside the filter.

Note: The diffuser should not touch the standing water layer during the pause period. This greatly reduces the amount of oxygen in the standing water layer, affecting the survival of the biolayer.

2. Place a storage container under the outlet tube. The water that it captures can be reused.
3. Pour the cleanest available water into the filter (turbidity should be less than 50 NTU).
4. Observe the water coming out of the outlet tube.
5. Continue adding water to the filter until the water coming out is clear. This may take 40-80 litres (10-20 gallons) of water.
6. Note the water level after the flow has stopped. The water level should be slightly below the diffuser.

Note: If the filtered water isn't clear after 100 litres (25 gallons), then the gravel was too dirty to start with. You will need to reinstall the filter with clean gravel.

TEST FLOW RATE

Tools:

- Watch
- Measuring container with 1 litre mark
- Storage container

Materials:

- 12 litres (3 gallons) of water

Steps:

1. Fill the filter reservoir to the top with water.
2. Place the measuring container under the outlet tube to collect the filtered water.
3. Measure the time it takes to fill the container to the 1 litre mark. The flow rate should be at a maximum of 0.4 litre/minute (see table to the right to convert seconds per litre into litres per minute).
4. If the flow rate is very slow (less than 0.3 L/minute, taking more than 3 minutes to fill the measuring container to 1 litre):
 - The filter will still work but it may plug faster requiring more frequent maintenance.
 - If it takes too long to filter a pail of water, the user may become impatient and use unfiltered water instead.
 - The flow rate can be improved by “swirling” the top layer of the sand and then scooping out the dirty water.
 - If a few “swirl & dumps” do not improve the flow rate substantially, the sand is either too fine or too dirty. In this case, the sand hasn’t been washed enough and needs to be replaced.
5. If the flow rate is faster than 0.4 L/minute, the filter may not work efficiently. In this case, the sand has been washed too much and needs to be replaced. A less preferable option is to run a considerable amount of water through the filter until the flow rate decreases (due to the capture of finer solids and faster growth of the biolayer).

Seconds per Litre	Litres per Minute
100	0.60
110	0.55
120	0.50
133	0.45
150	0.40
171	0.35
200	0.30

Note: The flow rate through the filter decreases as the height of the water in the reservoir drops. As the water level reaches the diffuser, treated water may only drip out of the outlet tube. It can take 40–90 minutes for the 12 litres in the reservoir to completely pass through the filter.

DISINFECT THE OUTLET

Tools:

- 1 m (3') of hose that just fits over the outlet tube
- Hose clamp (if available)
- Funnel (can be made from the top of a pop or water bottle)

Materials:

- Chlorine solution (e.g. 1 teaspoon 5.25% bleach to 1 litre of water)
- 12 litres (3 gallons) of water



Note: This step is used when starting the filter or during maintenance by a filter technician. Disinfecting the outlet tube is not normally done by the users.

Steps:

1. Place the hose over the outlet tube.
2. Clamp the hose in place with the hose clamp.
3. Place the funnel on the other end of the hose.
4. Hold the funnel higher than the top of the filter, and pour 1 litre of chlorine solution into the funnel.
5. Hold in place for 2 minutes.
6. Remove the hose and drain the chlorine solution.
7. Wipe the outside of the tube with a clean, chlorine-soaked cloth.
8. Add 12 litres (3 gallons) of water to the top of the filter and wait 30 minutes to flush the chlorine out. Instruct the user not to use this water for drinking or cooking.
9. Place the lid on the filter.



Disinfecting the outlet using a funnel and hose

Stage H – Operation, Maintenance and Follow-Up

ESTABLISHING THE BIOLAYER

The biolayer is the key component of the filter that removes pathogens. Without it, the filter removes about 30-70% of the pathogens through mechanical trapping and adsorption. The ideal biolayer will increase the treatment efficiency up to 99% removal of pathogens.

It may take up to 30 days for the biolayer to fully form. During that time, both the removal efficiency and the oxygen demand will increase as the biolayer grows. The biolayer is NOT visible – it is NOT a green slimy coating on top of the sand. The filtration sand may turn a darker colour, but this is due to the suspended solids that have become trapped.

The water from the filter can be used during the first few weeks while the biolayer is being established, but disinfection, as always, is recommended during this time.

DAILY USE

All household users, including children, need to be taught how and why the filter works and about its correct operation and maintenance. Children are frequently the main users of the filter. Proper use includes the following practices:

- Use the filter at least once every 1-2 days, preferably 2-4 times each day
- Use the same source of water every day to improve the treatment efficiency
- Use the best source of water (least contaminated) that is available – the better the source water, the better the treated water will be
- The turbidity of the source water should be less than 50 NTU. If it is more turbid, then sediment or strain the water before using the biosand filter.
- The diffuser must always be in place when pouring water into the filter – never pour water directly onto the sand layer. Slowly pour the water into the filter.
- The lid should always be kept on the filter
- Use a separate container for collecting the source water
- Use a separate safe storage container that has the following qualities:
 - Strong and tightly fitting lid or cover
 - Tap or narrow opening at the outlet
 - Stable base so it doesn't tip over
 - Durable and strong
 - Should not be transparent (see-through)
 - Easy to clean
- Store treated water off the ground in a shady place in the home
- Store treated water away from small children and animals
- Drinking treated water as soon as possible, preferably the same day

- Water must always be allowed to flow freely from the filter. Do **NOT** plug the outlet or connect a hose to it. Plugging the outlet tube could increase the water level in the filter, which could kill the biolayer due to lack of oxygen. Putting a hose or other device on the outlet can also siphon or drain the water in the filter, dropping the water level below the sand layer and drying out the filter.
- Do **NOT** store food inside the filter. Some users want to store their food on the diffuser because it is a cool location. The water in the top of the filter is contaminated, so it will contaminate the food. Also, the food attracts insects to the filter.
- The filtered water should always be disinfected to ensure the highest quality

Tip: The sound of water dripping from the outlet into the storage container can be irritating. The closer you place the container to the outlet, the less noise there will be. A container with a small opening also reduces dripping noise and prevents recontamination of the filtered water.

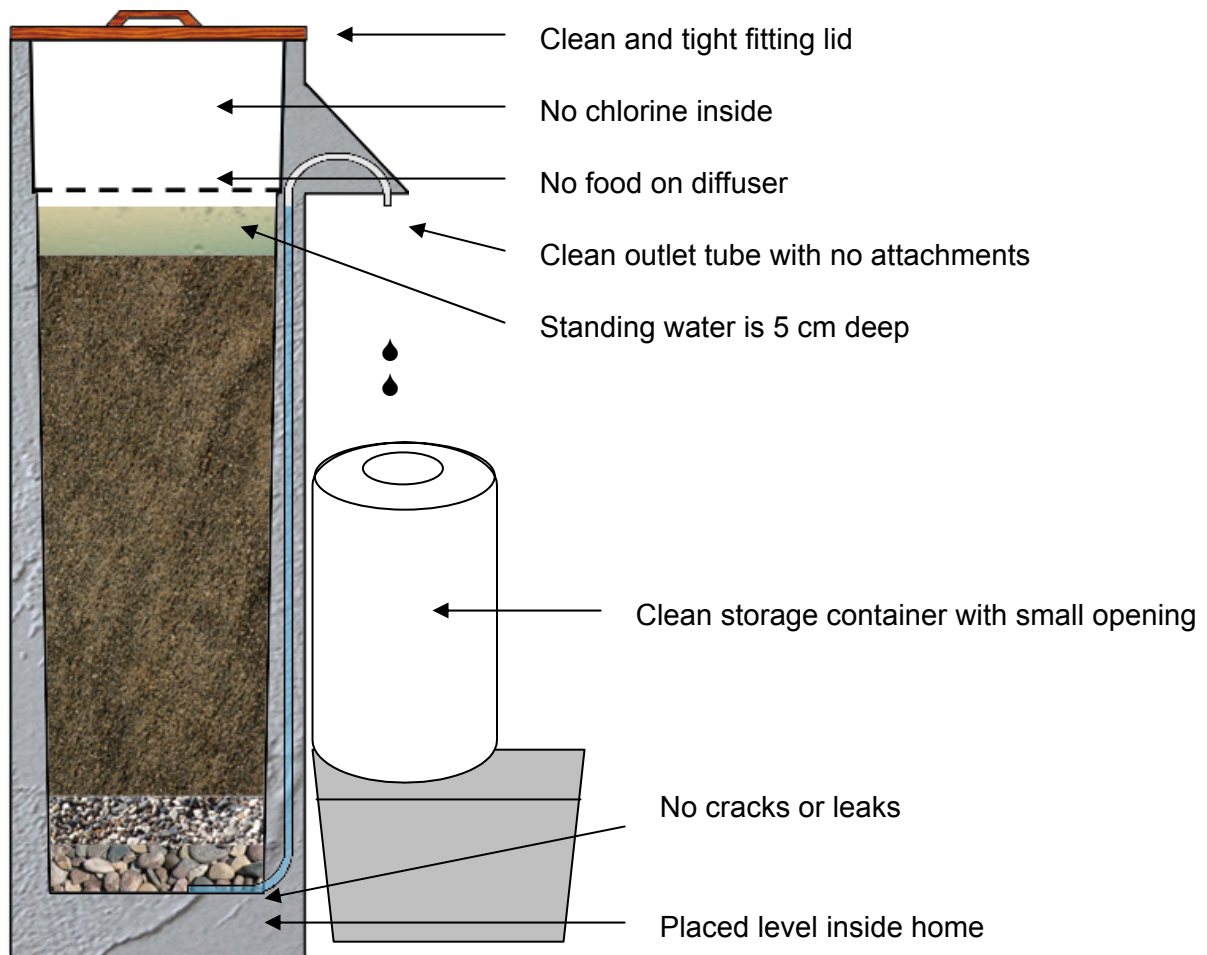

MAINTENANCE

There is some key maintenance tasks that are required after a filter has been installed and used regularly.

- The outlet tube will become contaminated during normal use via dirty hands, animals, or insects. Clean the outlet tube regularly with soap and water or a chlorine solution.
- Clean the inside of the treated water storage container when it looks dirty, when you do regular maintenance or at least once a month. **Do NOT pour chlorine into the top of the filter – it will kill the biolayer.** To clean the storage container:
 - Wash your hands before cleaning the container
 - Scrub the inside of the container with soap and treated water
 - Empty the soapy water through the tap
 - Rinse the container with a little treated water
 - Add chlorine to water in the storage container – let it sit for 30 minutes – if chlorine is not available, let the container air dry
 - Empty the remaining water through the tap
 - Clean the tap with a clean cloth and chlorine solution (such as bleach)
- The entire filter should be cleaned regularly (e.g. lid, diffuser, outside surfaces).



Chlorine works well to disinfect the treated water and clean surfaces, but do NOT pour chlorine into the top of the filter.

SWIRL & DUMP

The flow rate through the filter will slow down over time as the biolayer develops and suspended solids are trapped in the upper layer of the sand. Users will know when the “swirl & dump” is required because the flow rate will drop to an unacceptable level. The filter is still effectively treating the water at this point; however the length of time that it takes to get a container of filtered water may become too long and be inconvenient for the user. Alternately, you can measure the flow rate and if it is less than 0.1 litre/minute, then the “swirl & dump” maintenance is required.

Steps:

1. Remove the filter lid.
2. If there is no water above the diffuser, add about 4 litres (1 gallon) of water.
3. Remove the diffuser.
4. Using the palm of your hand, lightly touch the very top of the sand and move your hand in a circular motion; be careful to not mix the top of the sand deeper into the filter.
5. Scoop out the dirty water with a small container.
6. Dump the dirty water outside the house in soak pit or garden.
7. Make certain the sand is smooth and level.
8. Replace the diffuser.
9. Wash your hands with soap and water.
10. Set up the storage container to collect the filtered water.
11. Refill the filter.
12. Repeat the swirl & dump steps until the flow rate has been restored.

The biolayer has been disturbed by the swirl and dump, but it will develop again over time. **It is recommended to disinfect the filtered water during this time.**

FOLLOW UP VISITS

It is essential to conduct follow-up visits with the users to ensure proper use and maintenance of the filters. There should be at least two follow up visits with a household: one during the first two weeks of use and then another visit 1 to 6 months later. Some implementers choose to do more follow up visits as their time and resources allow.

During follow up visits, ensure that the filter is being operated and maintained as described in this manual. Example checklists and monitoring forms are available in Appendix 5.

KEY OPERATING CONDITIONS

Water quality testing can be done to check that the biosand filter is working. Testing the levels of microbiological, chemical and physical contamination in the source water and filtered water allows you to calculate the percent removal rates. However in practice, water quality testing can be complex, time consuming, difficult to interpret, and expensive.

Alternatively, CAWST recommends checking selected key operating conditions to ensure that the biosand filter is working effectively. If a biosand filter is not installed or being operated properly, then you can assume that it is not working effectively and producing high quality water on a consistent basis.

The following eight operating conditions must be met for the Version 10 biosand filter to work properly and consistently. Checks of the key operating conditions can be made at any time by the users, the Community Health Promoter or the Filter Technician that is active in the area.

1. Filter is used for at least one month since installation.
2. Filter is used at least once each day.
3. Source water is not too turbid (less than 50 NTU).
4. The concrete filter body is not leaking.
5. Diffuser is in place and in good condition.
6. Water level is 5 cm above the sand during the pause period.
7. Top of sand is level.
8. Flow rate is 0.4 litres per minute or slower (Note: The flow rate for Version 8 or Version 9 is 0.6 litres per minute or slower).

CAWST recommends checking these eight operating conditions during follow up visits and fixing any identified problems to ensure the best results.

6 References

- Buzunis, B. (1995). Intermittently Operated Slow Sand Filtration: A New Water Treatment Process. Department of Civil Engineering, University of Calgary, Canada.
- Baumgartner, J. (2006). The Effect of User Behavior on the Performance of Two Household Water Filtration Systems. Masters of Science thesis. Department of Population and International Health, Harvard School of Public Health. Boston, Massachusetts, USA.
- Duke, W. and D. Baker (2005). The Use and Performance of the Biosand Filter in the Artibonite Valley of Haiti: A Field Study of 107 Households, University of Victoria, Canada.
- Earwaker, P. (2006). Evaluation of Household BioSand Filters in Ethiopia. Master of Science thesis in Water Management (Community Water Supply). Institute of Water and Environment, Cranfield University, Silsoe, United Kingdom.
- Elliott, M., Stauber, C., Koksai, F., DiGiano, F., and M. Sobsey (2008). Reductions of E. coli, echovirus type 12 and bacteriophages in an intermittently operated 2 household-scale slow sand filter. *Water Research*, Volume 42, Issues 10-11, May 2008, Pages 2662-2670.
- Ngai, T., Murcott, S. and R. Shrestha (2004). Kanchan Arsenic Filter (KAF) – Research and Implementation of an Appropriate Drinking Water Solution for Rural Nepal.
- Palmateer, G., Manz, D., Jurkovic, A., McInnis, R., Unger, S., Kwan, K. K. and B. Dudka (1997). Toxicant and Parasite Challenge of Manz Intermittent Slow Sand Filter. *Environmental Toxicology*, vol. 14, pp. 217- 225.
- Stauber, C., Elliot, M., Koksai, F., Ortiz, G., Liang, K., DiGiano, F., and M. Sobsey (2006). Characterization of the Biosand Filter for Microbial Reductions Under Controlled Laboratory and Field Use Conditions. *Water Science and Technology*, Vol 54 No 3 pp 1-7.
- Sobsey, M. (2007). UNC Health Impact Study in Cambodia. Presentation, Cambodia.
- Stauber, C. (2007). The Microbiological and Health Impact of the Biosand Filter in the Dominican Republic: A Randomized Controlled Trial in Bona. PhD Dissertation, Department of Environmental Sciences and Engineering, University of North Carolina, Chapel Hill, USA.

Appendix 1: Concrete Biosand Filter Version 10.0 Mold Design

Biosand Filter Manual



Tips for Working with a Welder

- The first time you have a mold made, book one week of time to work directly with the welder or check in periodically to make sure they understand the instructions – don't expect to simply drop off the drawings and come back later to pick up a finished mold.
- Explain to your welder what the mold is for and what are the most critical parts of it – if they don't know what it does, they won't know what's necessary to make it work.
- Set up a contract with your welder that states you must have a working mold which has been tested and produces a concrete filter before you will pay in full.
- Take the time to select sheet metal and angle iron that is straight and flat with as little rust as possible on the sheet metal.
- The 3-sided piece of the exterior mold can be bent from one piece of sheet metal instead of welding 3 pieces together, if the welding shop has the tools to do so. Be sure to adapt the measurements to fit the requirements of the mold.
- It may be useful to build jigs to keep the plates square while welding.
- If you are having trouble keeping the interior mold boxes square, consider welding braces across all the openings (on the inside of the box).
- All measurements are in millimeters (imperial units in brackets) unless otherwise stated.
- **If you have questions, email us – that's what we're here for! cawst@cawst.org**

Overview of the Steel Mold

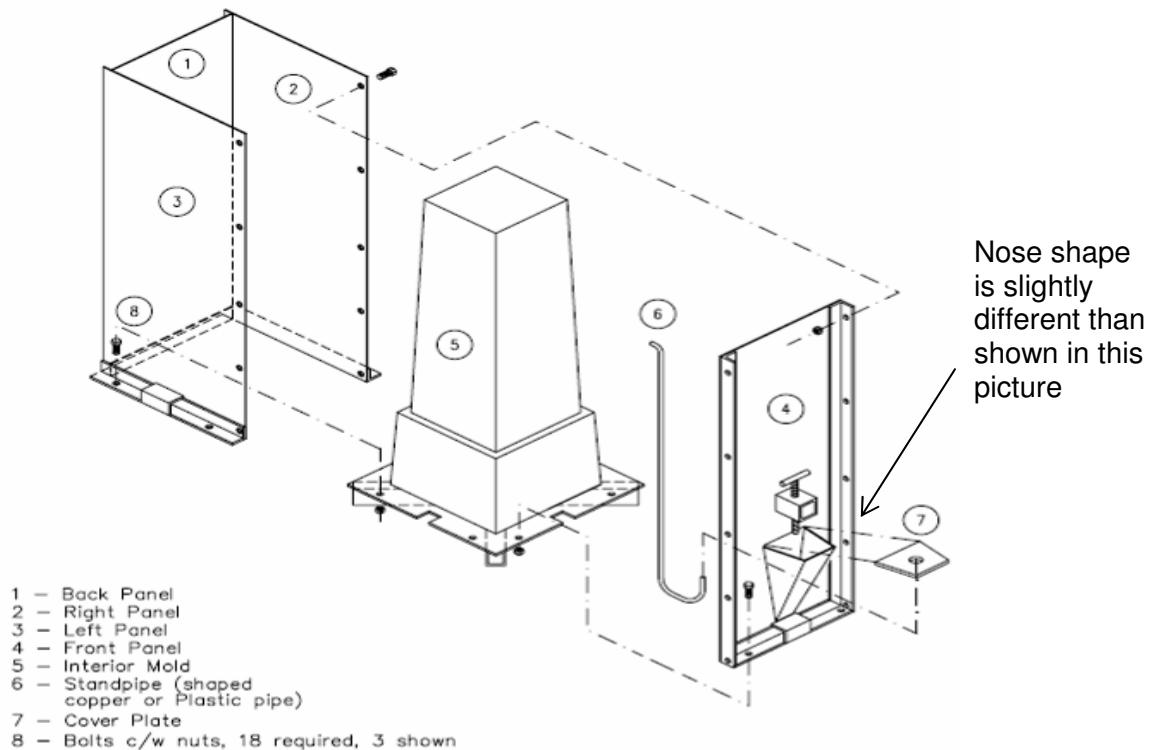

Part A: Cutting the Pieces

Quantity	Description
1 sheet*	3 mm (1/8") thick steel plate, often available in 1220 mm x 2440 mm (48" x 96") sheets. Recommend using new steel plate that is not rusted.
1† 1	6 mm (1/4") thick steel plate – one piece 1016 mm x 160 mm (40" x 6.5") – one piece 387 mm x 387 mm (15 1/4" x 15 1/4")
3210 mm (127")	38 mm (1 1/2") x 38 mm (1 1/2") x 3.2 mm (1/8") (wall thickness) angle iron
1435 mm (56 1/2")	38 mm (1 1/2") x 38 mm (1 1/2") x 3.2 mm (1/8") (wall thickness) square tubing
610 mm (24")	16 mm (5/8") diameter steel rod (or four 5/8" diameter bolts 152 mm (6") long)
229 mm (9")	25 mm (1") diameter threaded rod (also known as all-thread or ready-rods)
2	25 mm (1") nuts (these nuts must be able to thread onto the 1" threaded rod)
140 mm (5 1/4")	13 mm (1/2") diameter threaded rod
1	13 mm (1/2") nut
28	10 mm (3/8") diameter bolts – 19 mm (3/4") long
28	10 mm (3/8") nuts

* Do not use steel that is less than 3 mm (1/8") to construct the steel mold. The mold bends and warps easily if steel less than 3 mm (1/8") is used. Use 4 mm (0.17") steel if 3 mm (1/8") steel is unavailable.
 † 6 mm (1/4") steel is best for creating the diffuser ledge and a strong base, especially if you are using a diffuser plate and not a diffuser basin. Use 5 mm (1/5") steel, if 6 mm (1/4") steel is unavailable.

Step 1: Layout and cut 3 mm (1/8") steel plate

All the 3.2 mm (1/8") thick pieces can be cut from a single sheet, as shown below. These pieces must be cut from uniformly **flat steel** (without any concave or convex areas). At least one side of these metal sheets should be **free of rust** (rust causes concrete to stick).

Note: The image below does not include the width of the cut lines, which will vary depending on the cutting apparatus used.

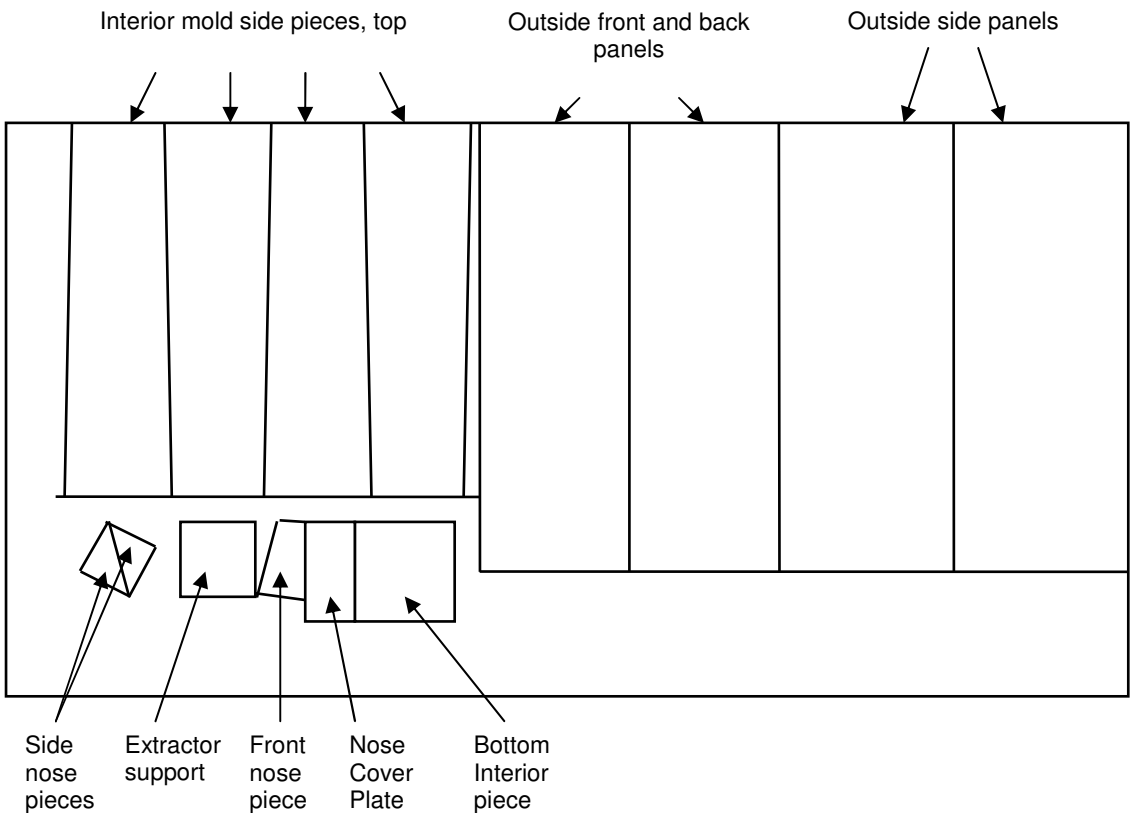

Step 1: Layout and cut 3 mm (1/8") steel plate – continued

Interior side pieces, top (4 pieces)

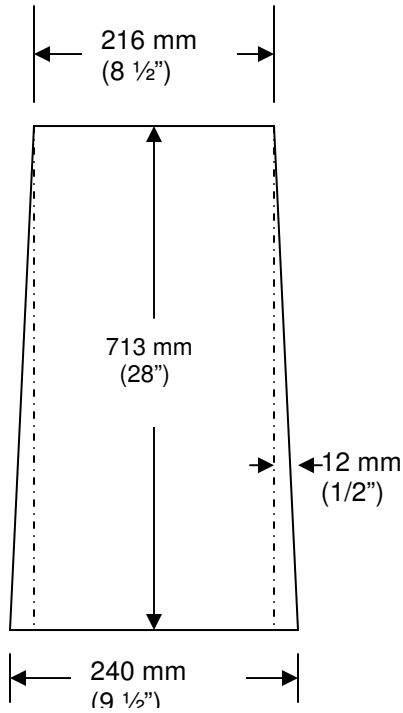

OR, cut these plates from one sheet as shown, but account for the width of the cuts

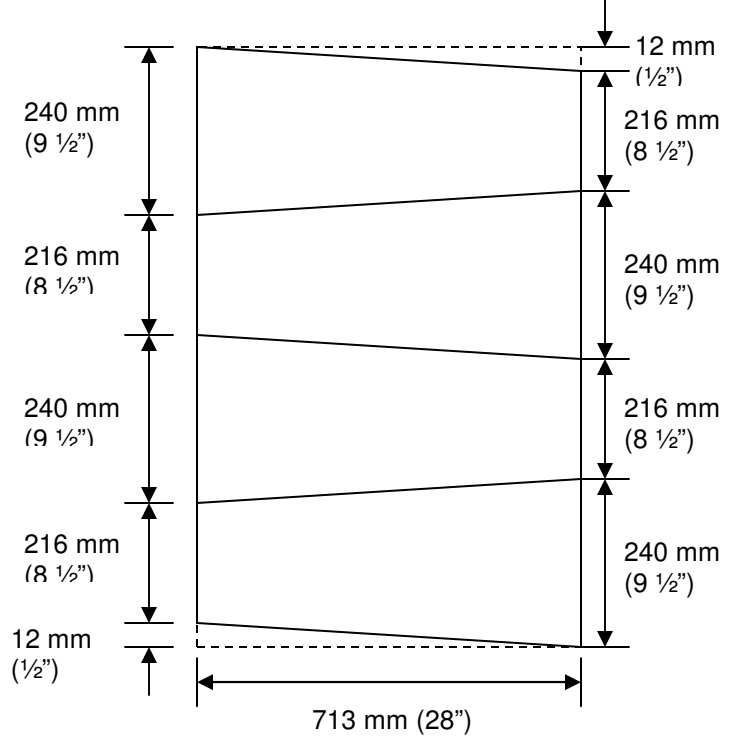

Bottom Inside Plate (1 Piece)

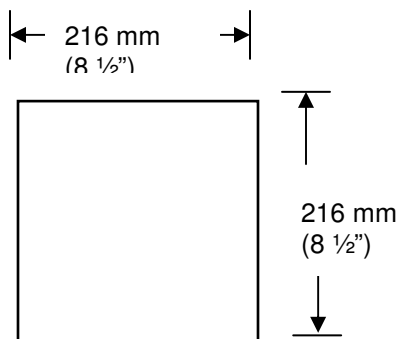

Extractor support (1 Piece)

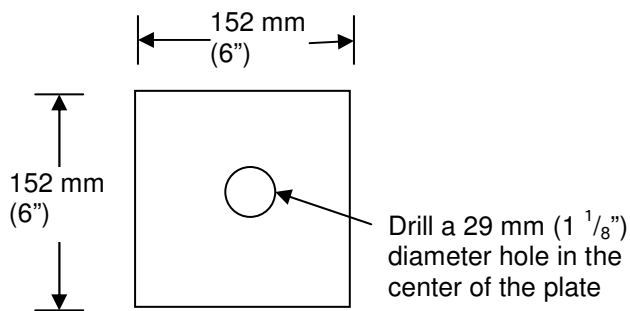

Step 1: Layout and cut 3 mm (1/8") steel plate – continued

Exterior Back and Front panels (2 pieces) Exterior Side panels (2 pieces)

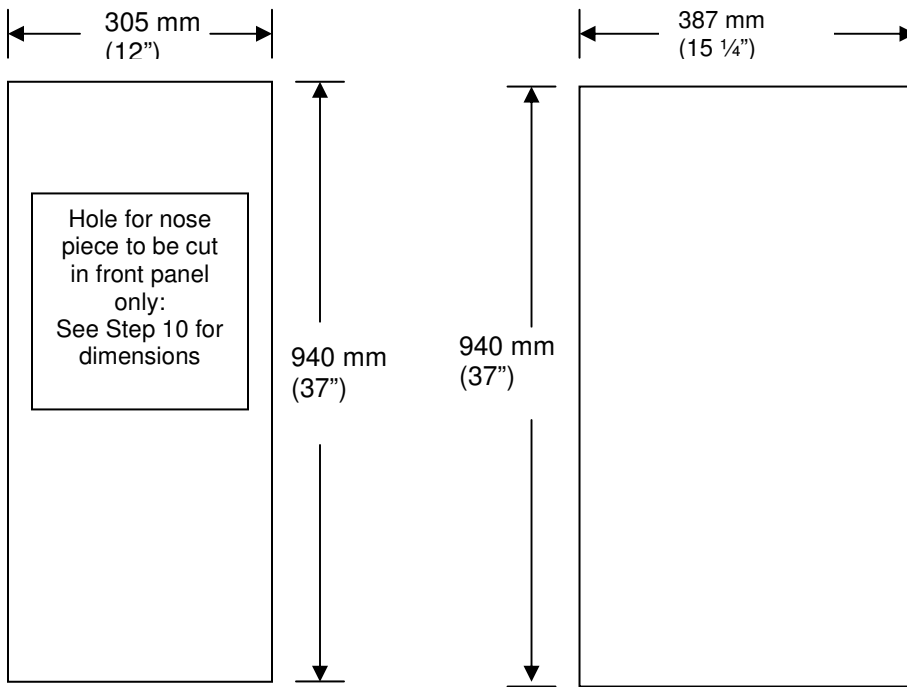

Side Nose Pieces (2 Pieces)

Front Nose Piece (1 Piece)

Note: this is not a right-angle triangle.

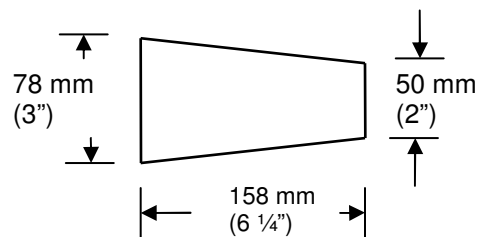
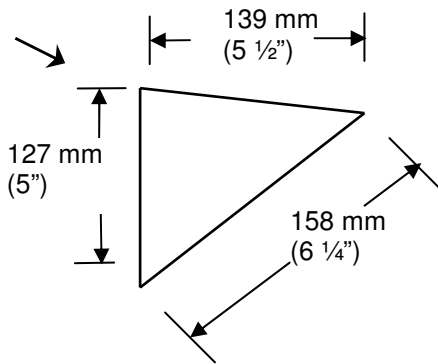

Nose Cover Plate (1 Piece)

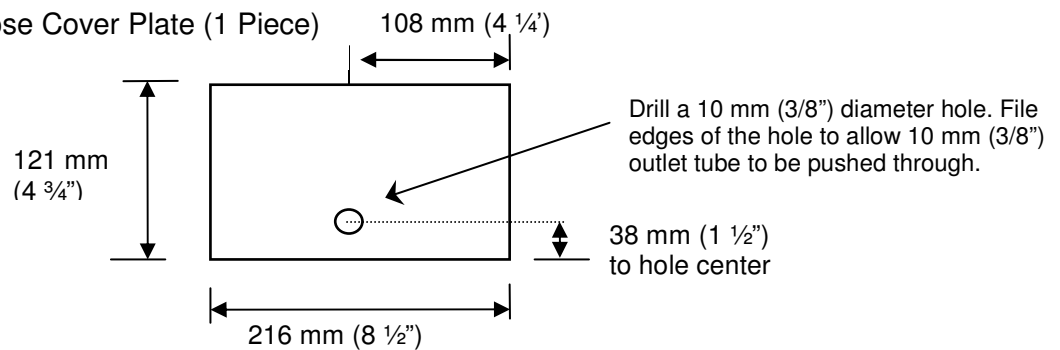

Step 2: Layout and cut 6.4 mm (1/4") steel plate

Interior side pieces, bottom (4 pieces)

OR, cut these pieces from one plate as shown below, but you must account for the width of the cuts

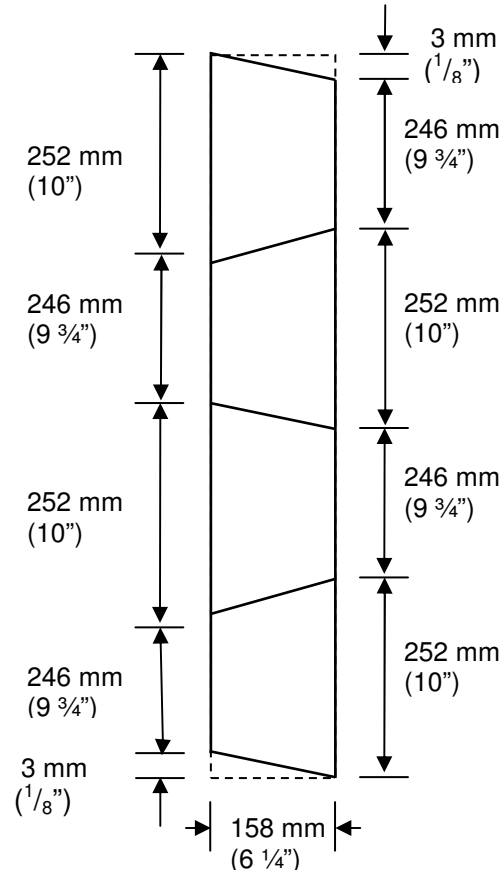
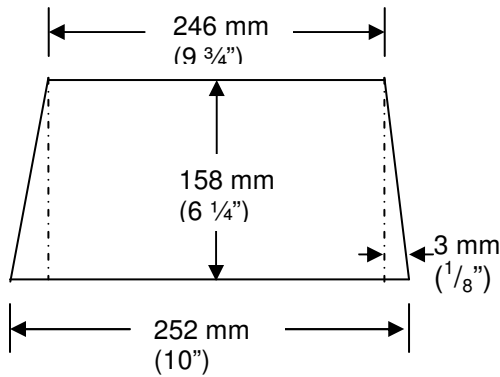

Base plate (1 piece) **Note: It is symmetrical.**

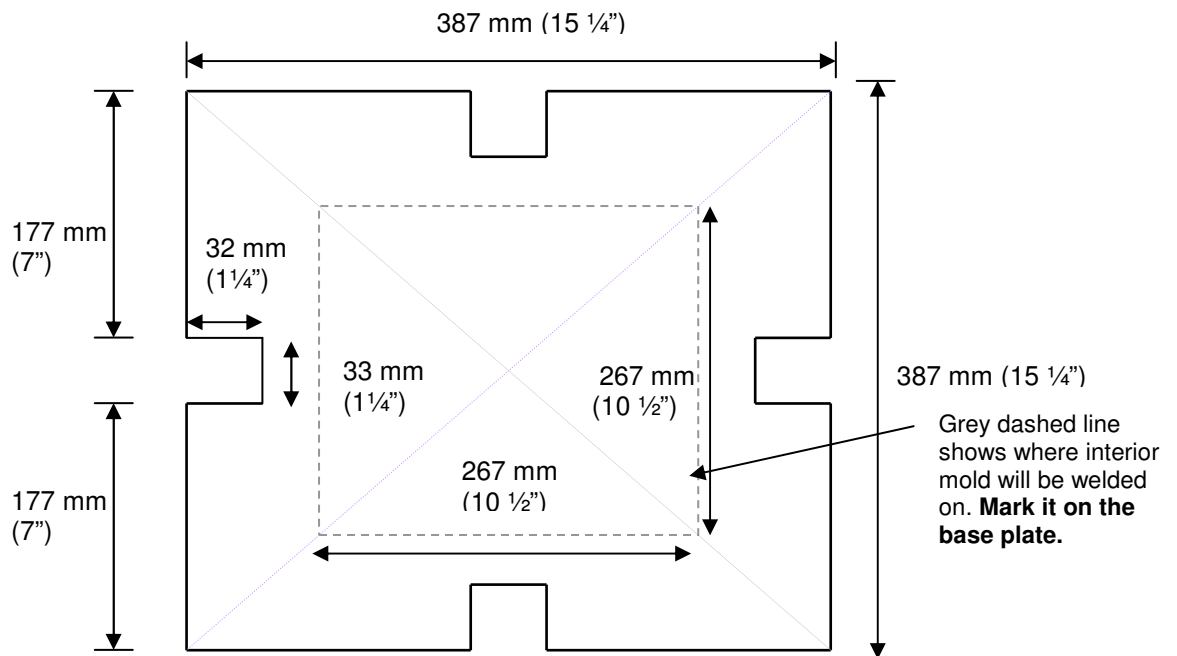

Step 3: Cut 38 x 38 (1 1/2" x 1 1/2") angle iron pieces

Total angle iron needed: 3213 mm (126 1/2")

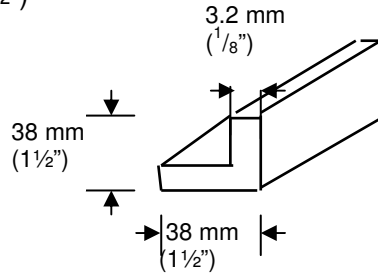

Two 940 mm (37") long pieces

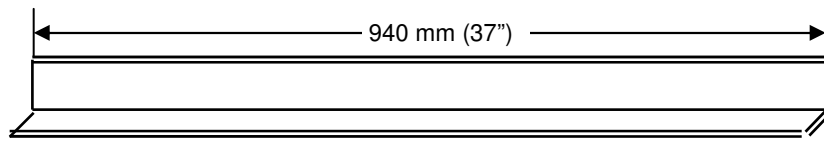

Two 387 mm (15 1/4") long pieces

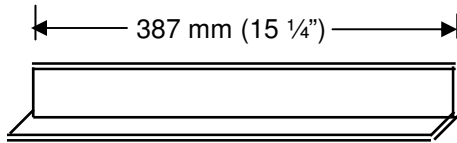

Two 305 mm (12") long pieces

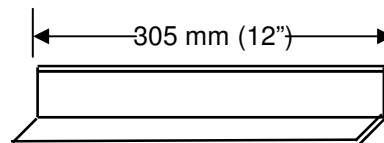

Step 4: Drill holes in angle iron

Note: Our recommended hole locations are shown below; however, the specific positions of the holes are not critical. The most important thing is to ensure that the holes on one piece of the mold match up with the holes on another piece of the mold after it is welded. If you drill the holes on every piece separately, they won't line up exactly and it will be difficult to insert the bolts each time you assemble the mold.

Depending on the available tools, there are three different options:

1. Drill the holes in the angle iron now but wait to drill the corresponding holes on the plates until the mold has been assembled (the method described in this manual).
2. Drill pilot holes (less than 11 mm) on every piece (angle irons and plates) as you go, but wait to finish drilling the holes to 11 mm (7/16") until the mold is assembled
3. Mark the holes now, but wait to drill all the holes until the mold is clamped together at a later stage (must be done with a handheld tool, not a drill press)

Step 4 - continued

Two 940 mm (37") long pieces of angle iron, with five 11 mm ($\frac{7}{16}$ ") diameter holes

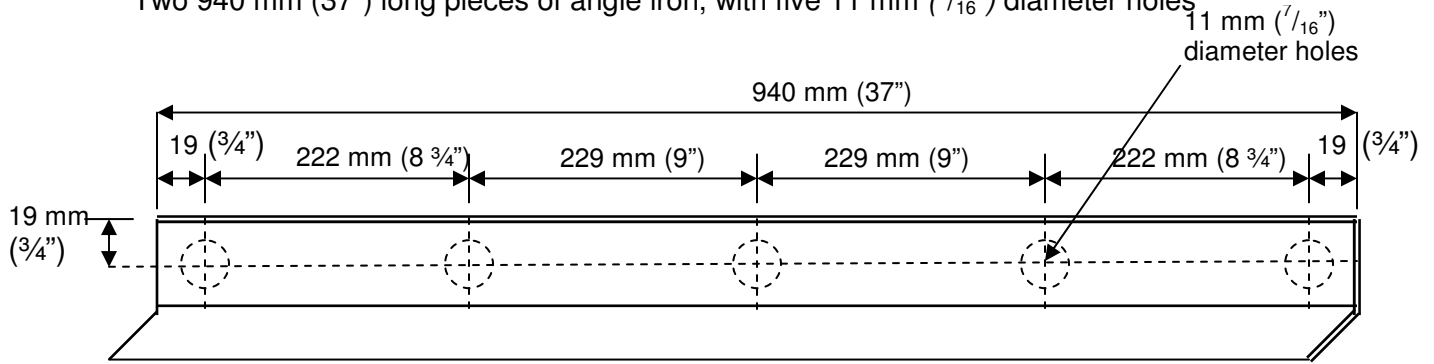

Two 387 mm (15 $\frac{1}{4}$ ") long pieces of angle iron, with two 11 mm ($\frac{7}{16}$ ") diameter holes

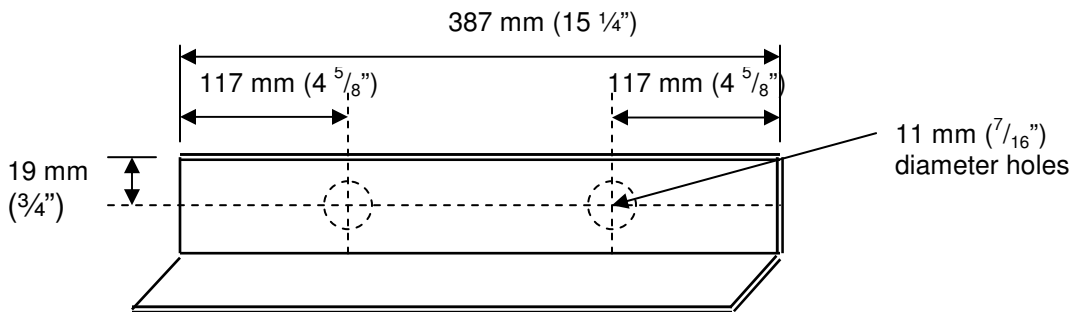

Two 305 mm (12") long pieces of angle iron, with two 11 mm ($\frac{7}{16}$ ") diameter holes

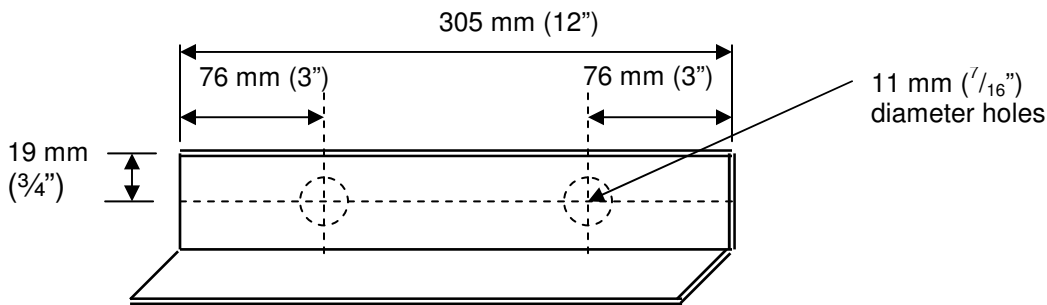

For only one of the 305 mm (12") pieces of angle iron, cut 38 mm (1 $\frac{1}{2}$ ") off each end of the angle iron, but only on the side that has no holes, as shown below.

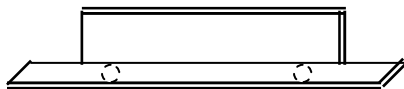

Step 5: Cut 38 mm x 38 mm (1 1/2" x 1 1/2") square tubing pieces

Total square tubing needed: 1435 mm (56 1/2")

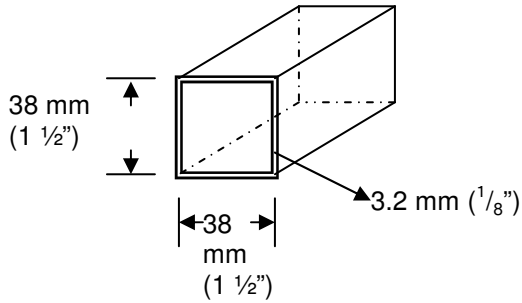

One (1) 387 mm (15 1/4") long piece

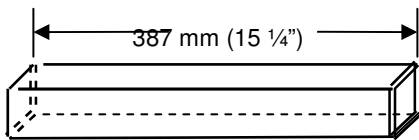

Two (2) 175 mm (6 7/8") long pieces

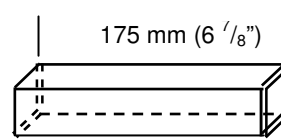

Five (5) 89 mm (3 1/2") long pieces

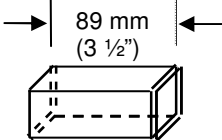

Four (4) 57 mm (2 1/4") long pieces

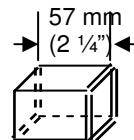

Step 6: Mark and drill holes in square tubing

One (1) 387 mm (15 1/4") long piece of square tubing, with 29 mm holes through two opposite sides

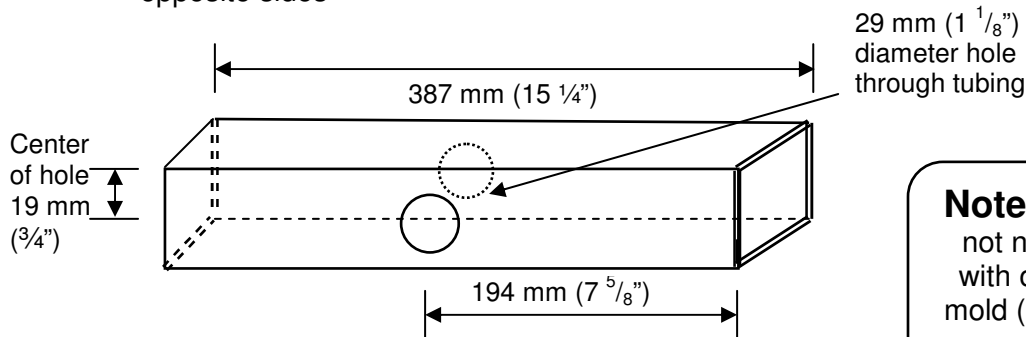

Note: These holes do not need to match up with other parts of the mold (as in Step 4), and can be drilled now.

Step 6: Mark and drill holes in square tubing – continued

One (1) 89 mm ($3\frac{1}{2}$ ") long piece of square tubing, with two (2) - 13 mm ($\frac{1}{2}$ ") holes through two opposite sides (this piece will be used in Step 10).

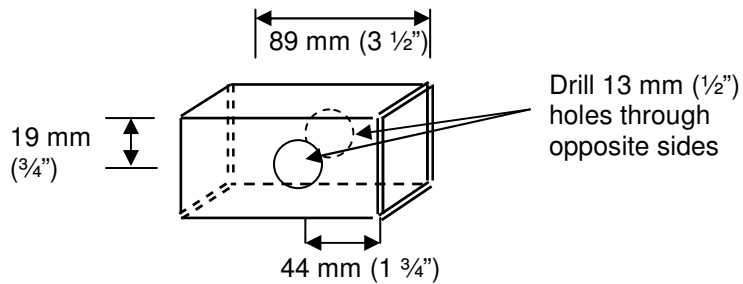
**Step 7: Cut 16 mm ($\frac{5}{8}$ ") diameter steel rods**

Cut four (4) 152 mm (6") long rods as shown below:

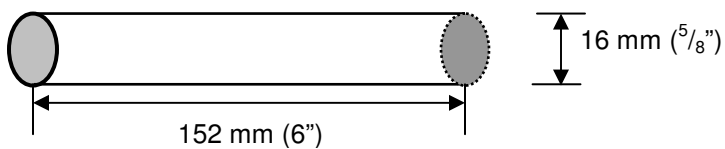

Part B: Welding

Step 8: Interior mold box

1. Welding the 3.2 mm ($\frac{1}{8}$ ") sheet steel: Stand the 4 'top interior side pieces' with the narrow ends up.

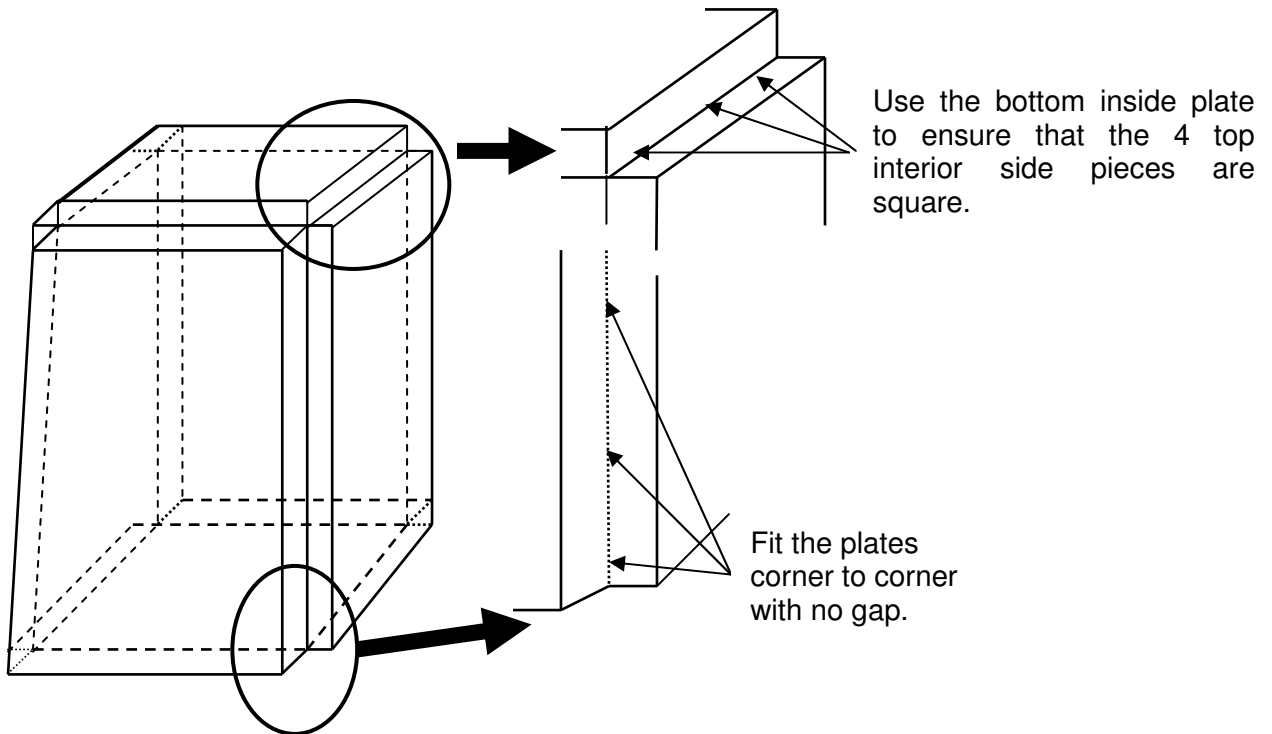

Step 8: Interior mold box - continued

2. Tack weld the top interior side plates together.
3. Check that the box is still square. If not, fix it.
4. Tack all 4 sides of the bottom inside plate to the top interior side plates.
5. Check that the box is still square. If not, fix it.
6. Weld the complete lengths joining the 4 top interior side plates, in the order shown:

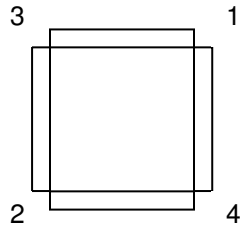

7. Check that the box is still square. If not, fix it.
8. Weld the edges of the top plate to the edges of the four side plates all the way around.
9. Welding the 6.4 mm ($\frac{1}{4}$ ") sheet steel bottom interior side pieces: Stand the 4 'bottom interior side pieces' with the narrow ends up.

Note: The following is the most important part of welding the mold. This part of the interior mold box must be square so that the thickness of all the concrete filter walls will be consistent. Take the time to make sure that these pieces are welded together squarely and attached squarely to the rest of the interior mold.

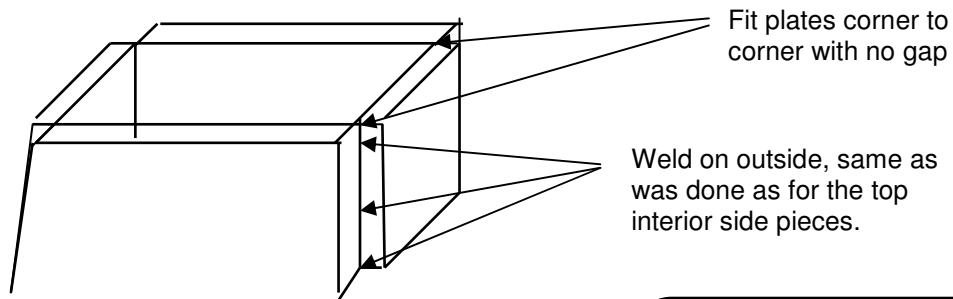

10. Tack the bottom interior side plates together.
11. Check that the box is still square. If not, fix it.

Note: Grind the welded edges to a smooth round corner along the full length. These form the inside corners of the filter when it is cast in concrete.

Step 8: Interior mold box - continued

12. Weld the complete lengths joining the 4 bottom interior side plates, in the order shown in instruction 5 (above).
13. Check that the box is still square. If not, fix it.
14. Place the top interior box (built in instructions 1-8) inside of the bottom interior box (instructions 9-12) as shown below.

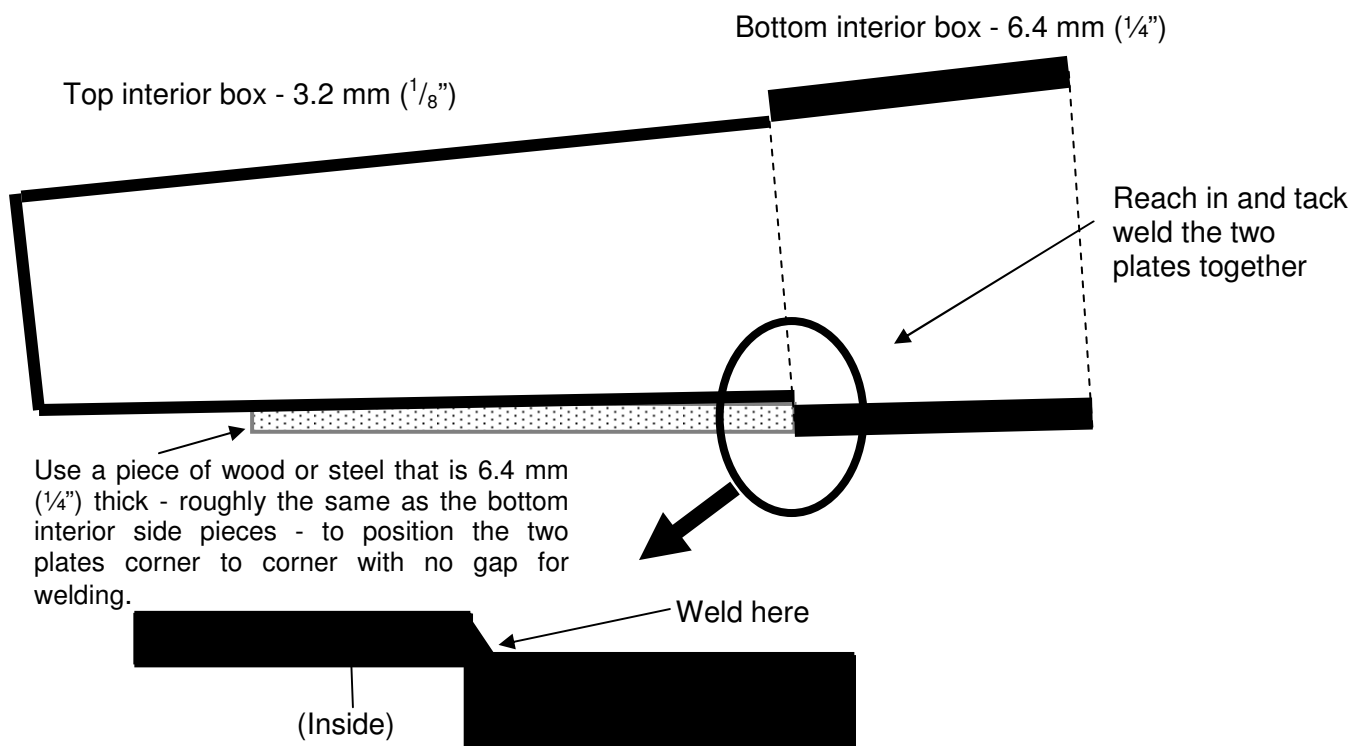

15. Tack weld all 4 sides of the top interior box to the bottom interior box on the inside.
16. Finish welding the boxes together, all the way around on the inside.

Note: This weld must be made on the inside of the box to ensure that a sharp lip is left on the outside of the box. That lip will form a ledge in the concrete to support the diffuser plate.

Step 9: Interior mold base

Weld four pieces of 89 mm (3 1/2") square tubing and one 25 mm (1") nut onto the base plate, as shown below. (Leave the 89 mm (3 1/2") square tubing with a hole through it for Step 10.)

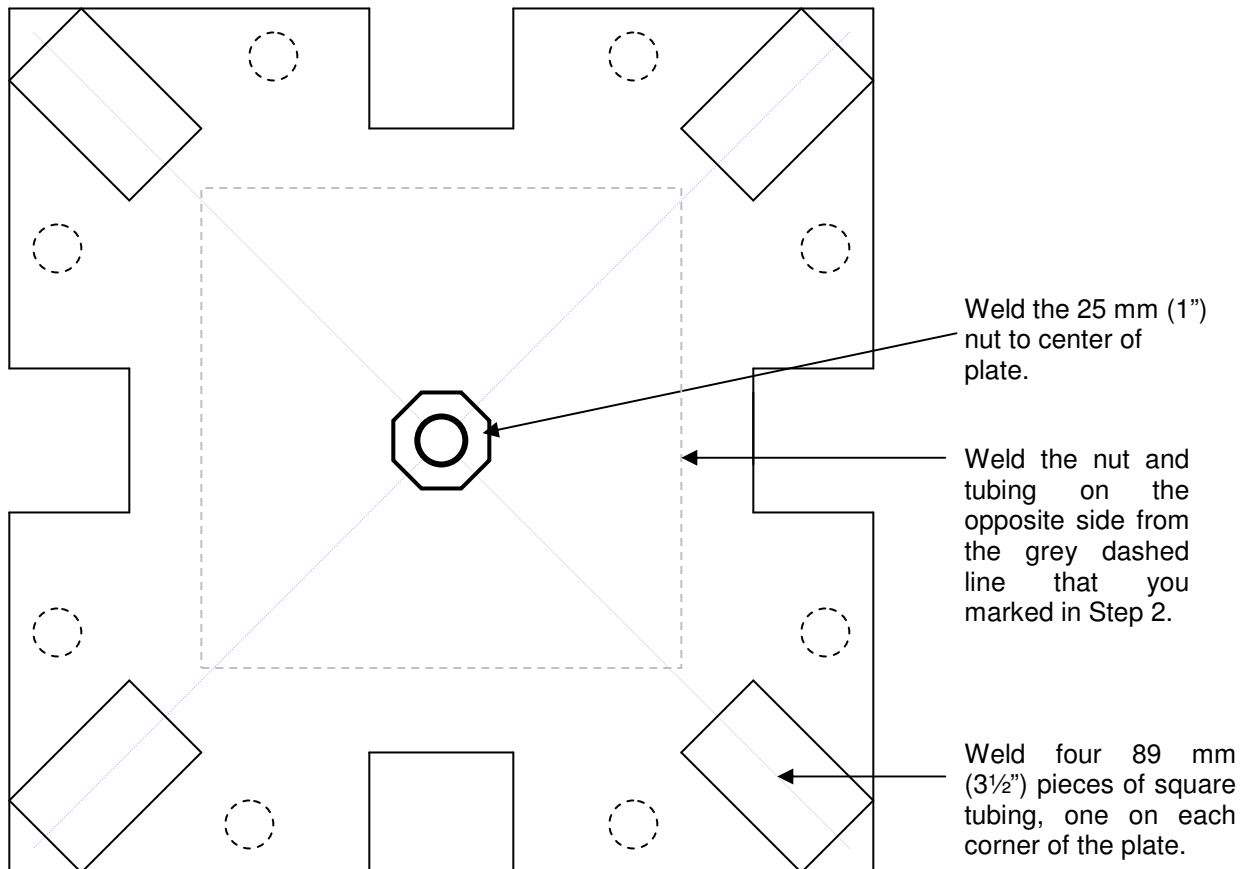

Do **not** drill the holes in the plate at this time. They are drilled once the exterior box has been constructed. See Step 12.

Step 10: Exterior mold - front panel

Take the one 305 mm (12") angle iron that has the ends cut off. Weld a 57 mm (2¼") square tubing onto the centre of the angle iron. Leave the other 305 mm (12") angle iron for Step 11.

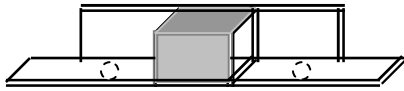

Cut a hole for the 'nose' in one of the 305 mm x 940 mm (12" x 37") exterior panels as shown below:

Then, weld angle iron onto 3 sides of the panel as shown below.

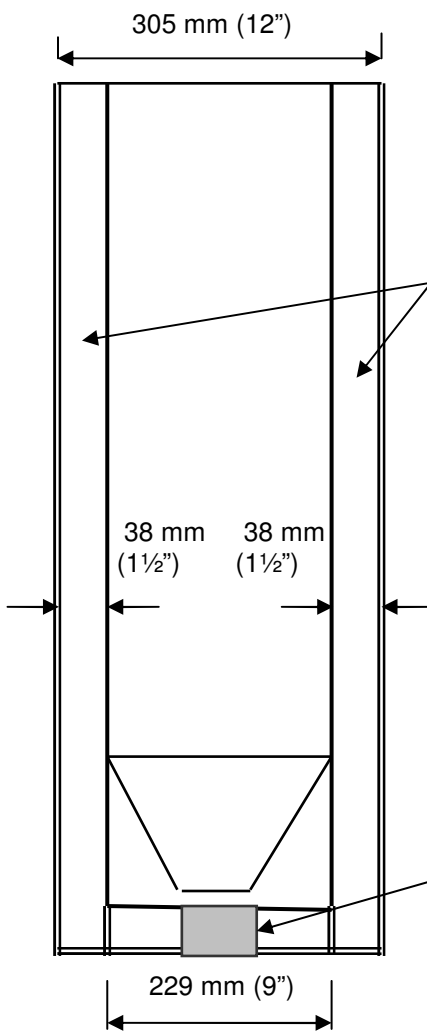
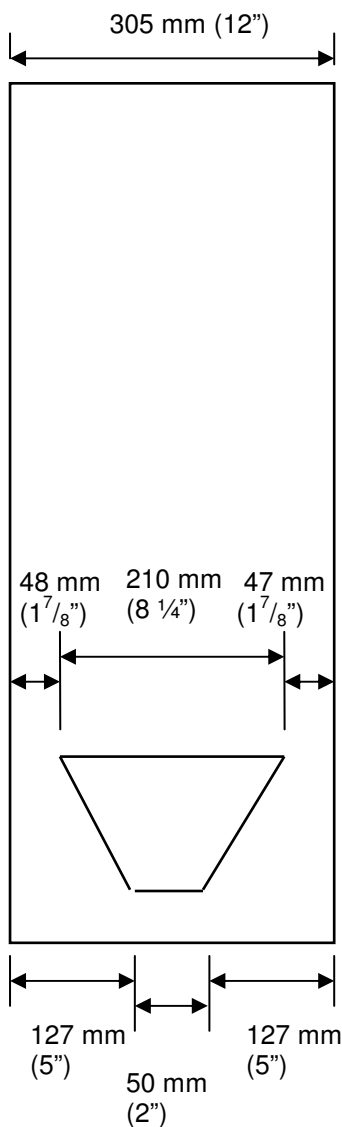

Weld a 940 mm (37") long angle iron onto each side of the plate as shown.

Weld the 305 mm (12") angle iron that you cut (above) to the front panel as shown

Note: The joints between the nose pieces and the front panel **DO NOT** form right angles.

Step 10: Exterior mold - front panel – continued

Weld the 13 mm nut over one of the holes on the remaining 89 mm long piece of square tubing. This nut is for the bolt that will hold the nose cover in place.

Weld the front nose piece to both side nose pieces, 158 mm (6 1/4") sides, and to the front panel (50 mm end). All welding should be done from the inside.

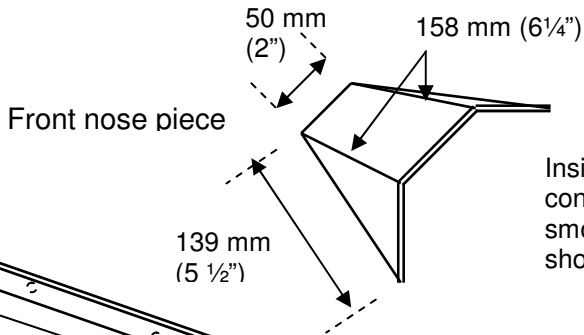

Inside welds should be continuous and ground smooth – these corners will show on the front of the filter.

Weld the 13 mm (1/2") nut over one of the holes on the remaining 89 mm (3 1/2") long piece of square tubing. This nut is for the bolt that will hold the nose cover in place. The 13 mm (1/2") nut should be facing the nose.

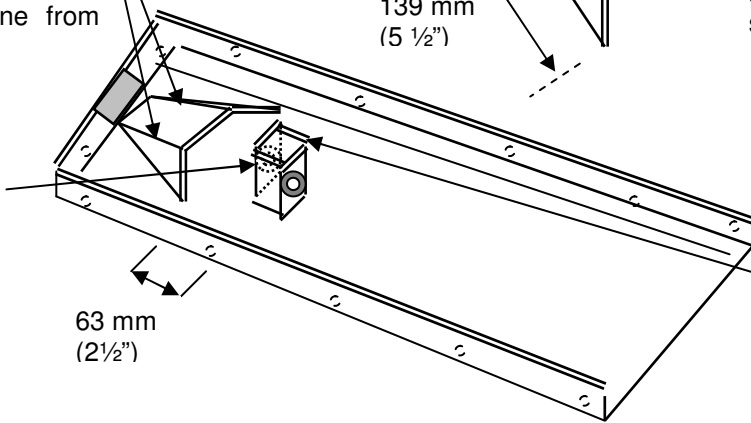

Weld the 89 mm (3 1/2") square tubing (with the nut welded over one hole) to the front panel, centered horizontally, 63 mm (1 3/4") from the bottom of the nose opening. The 13 mm (1/2") nut should be facing the nose.

Step 11: Exterior mold – back and side panels

Weld a 57 mm (2 1/4") piece of square tubing onto the center of one of the 387 mm (15 1/4") angle irons.

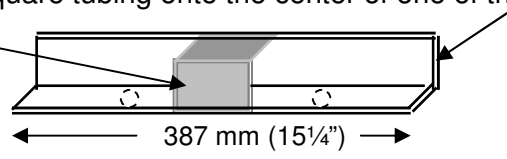

Weld that angle iron to one of the 387 x 940 mm (15 1/4" x 37") exterior side panels.

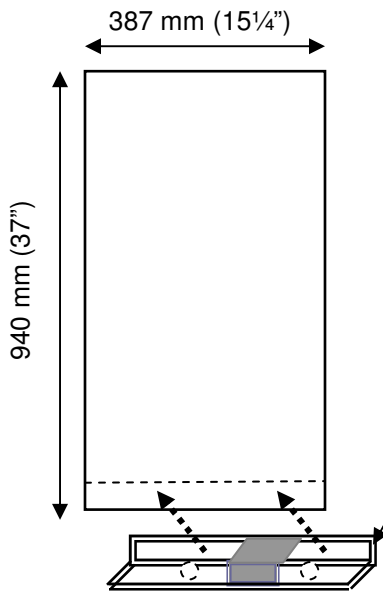

Weld angle iron across the 387 mm (15 1/4") end of the panel

Repeat the entire process for the other 387 mm (15 1/4") angle iron and the other 387 X 914 mm (15 1/4" x 37") exterior side panel.

Step 11: Exterior mold – back and side panels – continued

Weld a 57 mm (2¼") piece of square tubing onto the center of the remaining 305 mm (12") angle iron.

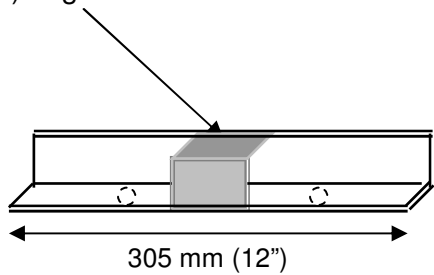

Weld that angle iron to the remaining 305 x 914 mm exterior panel as shown below.

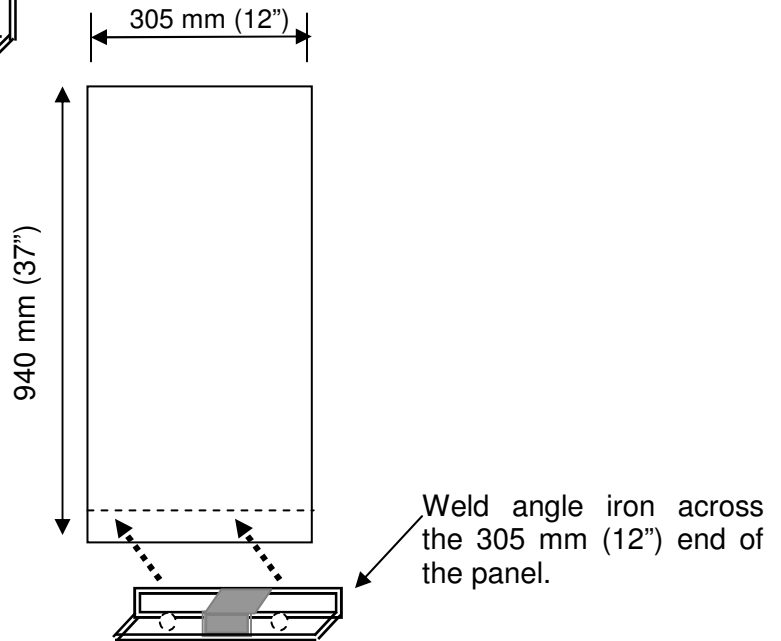

Stand the exterior back and side panels as shown below.

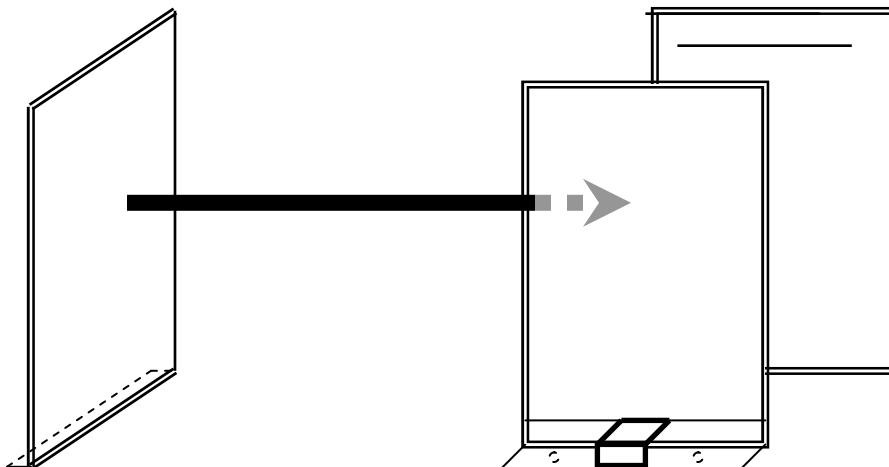

Place the exterior back panel 38 mm (1½") from the edge of the exterior side panels. Make sure the panels are square – at 90° angles to each other.

Step 11: Exterior mold – back and side panels – continued

Tack weld the panels together and then check to make sure it's square. Once they are square, then stitch weld the panels together from the outside.

Note: It is not necessary to weld the entire length of the joints. A stitch weld which runs the length of the joint and has 25 mm (1") welds spaced 150 mm (6") apart (centre-to-centre) is sufficient.

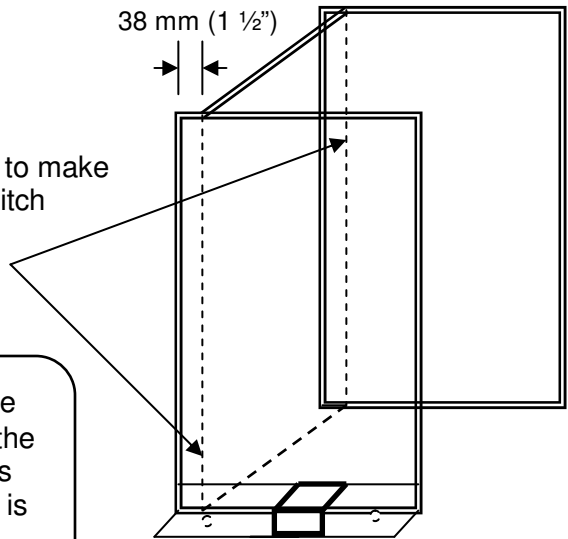

Step 12: Mold Completion

Place the exterior mold panels on top of the base plate as shown below. Clamp all the components together so that they will not move. Complete the drilling of the bolt holes – wherever there is a hole in the angle iron, drill through the corresponding plate.

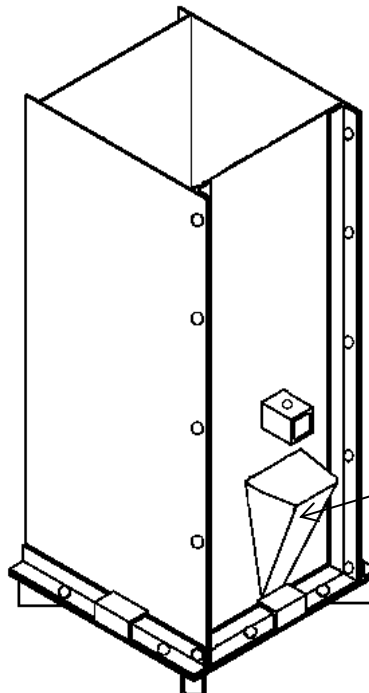

Nose shape is slightly different than shown in this picture.

Step 12: Mold Completion - continued

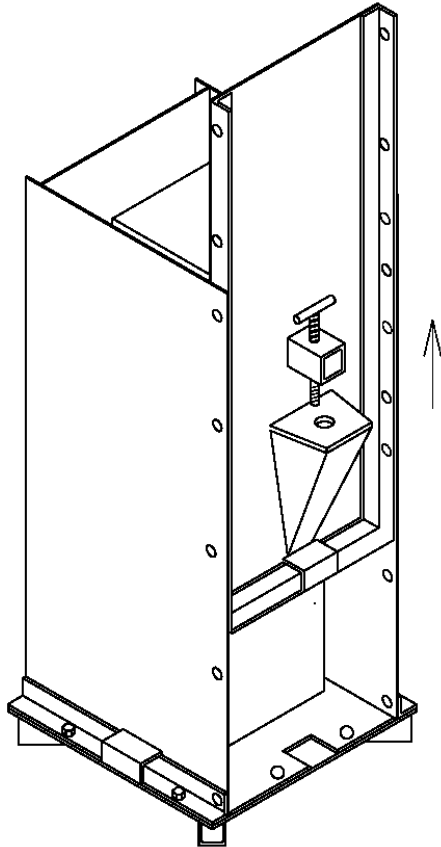

1. Bolt the 3-sided exterior panel to the base plate.
2. Place interior mold box on top of base plate.
3. Raise front panel one set of holes and bolt to side panels.
4. Make sure that the interior mold box is centred – equally distant from each side of the exterior mold, 22 mm minimum.
5. Reach in and tack weld the interior mold box in place.
6. Unbolt and remove all of the exterior mold panels.
7. Weld the interior mold box to the base plate all the way around.
8. On a non-working surface, mark the interior mold to indicate which side is front (facing the nose plate).

Note: Grind smooth the welds on the inner mold with the grinding wheel in this direction. **Do not** grind or sand into the inner mold because this will create a cavity that the concrete will fill and prevent removing the mold.

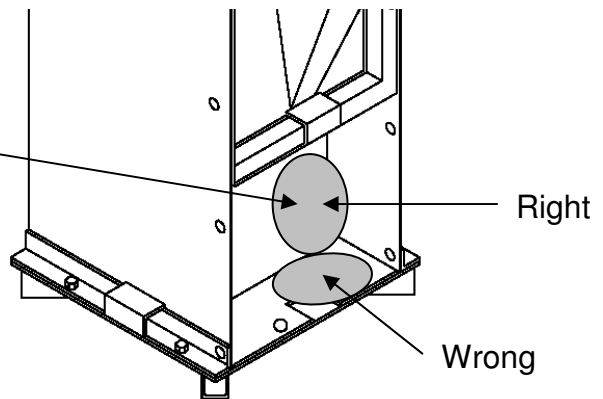

Step 13: Extractor

Take one 387 mm (15¼") square tubing and two 175 mm long pieces of square tubing.

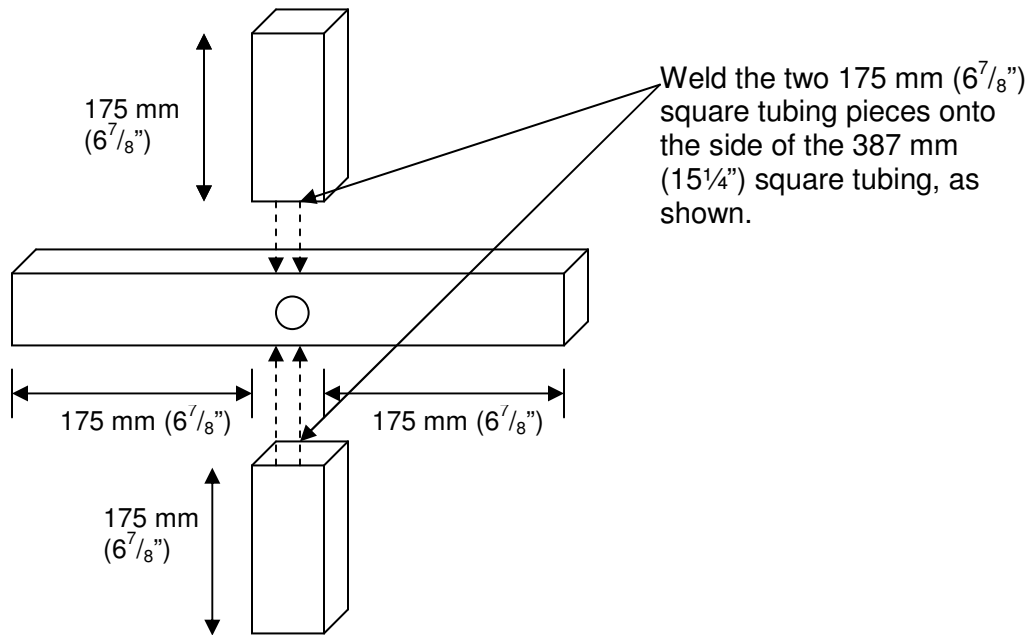

Lining up the holes, weld the extractor support piece onto the square tubing. Weld the 152 mm x 16 mm (6" x 5/8") diameter steel rods onto the opposite side.

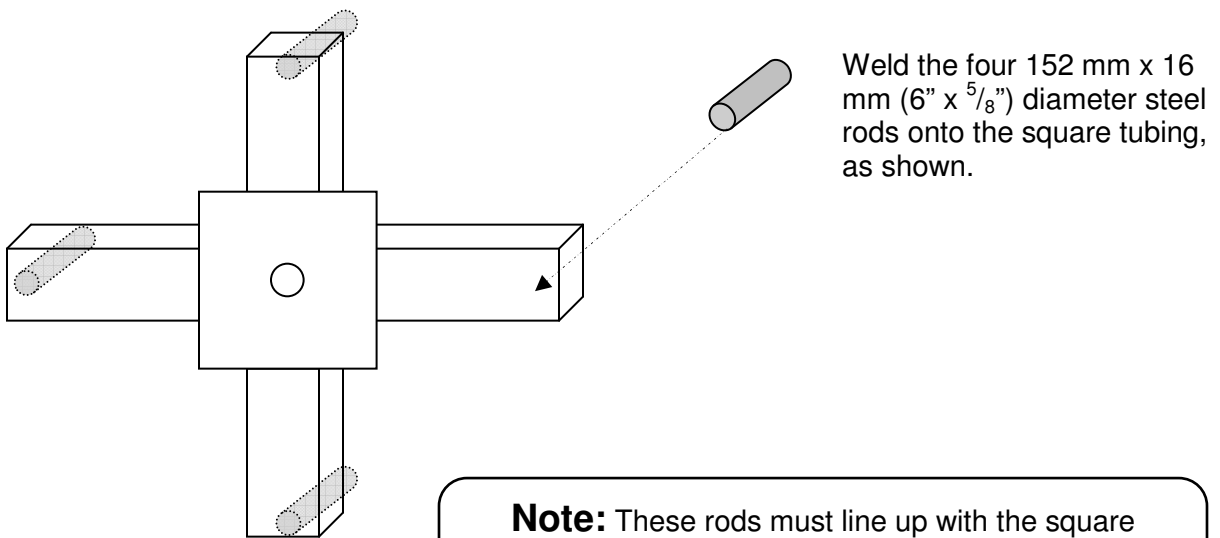

Note: These rods must line up with the square notches on each side of the base plate. **Test to make sure they line up before you weld.**

Step 13: Extractor - continued

Weld a scrap piece of rod approximately 50 mm (2") long to the end of the 25 mm (1") diameter threaded rod to form the extractor bolt.



Weld a scrap piece of rod approximately 63 mm (2½") long to the end of the 13 mm (½") diameter threaded rod to form the bolt which holds the nose cover in place.

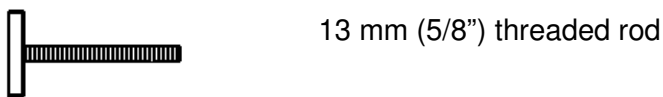

Step 14: Finishing

- Welds on any surface that contacts concrete must be ground down to a smooth finish.
- The dark "mill scale" on the surface of sheet metal is the smoothest finish, so it can be left on surfaces that contact concrete unless there is weld material to be ground off.
- **DO NOT PAINT THE INSIDE OF THE MOLD** – (especially those surfaces that will contact concrete) it will cause problems in removing the hardened filter from the mold.
- **PAINT THE OUTSIDE OF THE MOLD** – use rust-proof paint to make your mold last longer.
- The pieces of the mold will be custom-fit to match each other, so mark each piece of the mold with an identifying mark (i.e. grind a notch into a non-working surface of each piece) to distinguish it from other molds.
- The mold should be oiled (with edible, food grade oil such as vegetable oil) for storage so that it doesn't rust, and stored indoors.

Appendix 2: Sieve Set Construction

Biosand Filter Manual

Tools:

- Hammer
- Saw
- Tape measure

Materials:

- Nails
- 1.3 cm (1/2") staples (if available)
- 2.5 cm x 2.5 cm (1" x 1") wood strapping
- 2.5 cm x 10 cm (1" x 4") wood
- 12 mm (1/2", 2 gauge) wire screen
- 6 mm (1/4", 4 gauge) wire screen
- 1 mm (0.04") wire screen
- 0.7 mm (#24 mesh) wire screen

Note: The mesh # indicates the number of openings per linear inch (2.5 cm), therefore 4 gauge screen would have 4 openings per inch, and 16 holes per square inch (6.25 cm²).

Screens should be made from metal wire since it is more durable and will last longer than nylon or fiberglass. These materials are weaker and will tear easily.

Steps:

1. Construct a square frame for the sieve.

Tip: Build the sieve to fit the screen!

- The suggested size is approximately 40 cm x 56 cm (16" x 22"). Two people can hold this size of a sieve. A smaller sieve can be constructed if only one person will be holding it. Other sizes may be constructed depending on the material available and the preference of the users.
- An organization in Brazil suspended their sieves from ropes so that they don't have to hold the weight of the sand; they only have to shake the sieve.
- The two longer sides can be made longer than 61 cm (24") to form handles.
- Don't make the sieve so large that it is too heavy to hold when filled with sand, or that the weight of the sand deforms the screen.



2. Cut a piece of screen that is larger than the frame, so that there is 2.5 cm (1") extra on all sides.
3. Centre the screen over the frame.

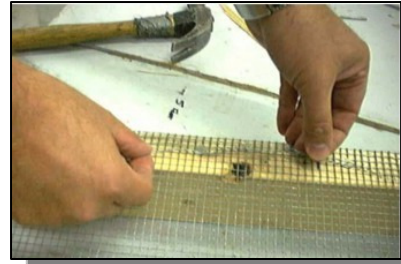

Tip: For the 0.7 mm (#24) mesh screen, it is necessary to add a piece of 12 mm (1/2") screen for support. Place 0.7 mm (#24) mesh on the frame first, followed by a piece of 12 mm (1/2") screen the same size, so that when you flip the sieve over and use it, the 12 mm (1/2") screen will be underneath the 0.7 mm (#24) mesh screen, supporting it.

4. Nail staples through the screen and into the frame on all 4 sides. If staples aren't available, pound a nail in halfway, and then bend it over and pound it into the frame.
5. Bend the excess screen back on itself so that the bent edge lines up with the outside of the frame, and the excess overlaps the rest of the screen. Doing so avoids sharp edges that could cut your hands while sieving.
6. Cut the 2.5 cm x 2.5 cm (1" x 1") wood strapping to the same lengths as your frame to form a covering frame.
7. Nail the covering frame over top of where you've nailed the screen to the frame.
8. Repeat the process until you have three sieves, each with a different screen size: 12 mm (1/2"), 6 mm (1/4") and 0.7 mm (0.03").

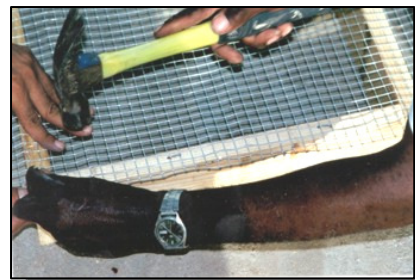

NOTE:

- A well-built sieve will last for a long time so it is worth taking the time to build it well and make it comfortable to use.
- Never use a sieve that has ANY holes in the screen or where the screen is separating from the frame.
- When the screen wears out, simply remove the wood strapping, pull off the old screen and attach a new piece of screen to the existing frame.



Appendix 3: Sand Sieve Analysis

Biosand Filter Manual

Purpose

The biosand filter requires a certain range of sand grain sizes to effectively treat drinking water. Conducting a sand sieve analysis provides the distribution of sand grain sizes for a sample of sand. This information can be used to:

1. Determine if the prepared sand (sieved and washed) is within the Effective Size (ES) and Uniformity Coefficient (UC) ranges recommended for the filtration sand in the biosand filter. This procedure is described in the Method and **Instructions to Analyze Prepared Sand** below.
2. Determine what useable sand will be produced from a sand source (e.g. a quarry) and how much sand will be rejected as too fine or too coarse. The sand that is larger than the top sieve (0.7 mm opening size) is too coarse for filtration sand and needs to be removed (though this size may be used as aggregate in constructing the concrete filter). If there is a large percentage of coarse sand, then the sand can be sieved at the quarry site to remove this coarse material before transporting it to your production site. This procedure is described in **Instructions to Determine % Rejected**.

Sand smaller than the finest sieve (0.1 mm opening size), which is collected in the catch pan at the bottom, is too fine for filtration sand and washing the sand in water will be required to remove this very fine sand (also known as rock flour).

3. Estimate if a sand source would be a good supply to produce filtration sand (once the sand had been prepared by sieving and washing). This is done by determining the Effective Size and Uniformity Coefficient for the portion of the sand sample that would be useable. This means performing the analysis method described below, but only using the portion of sand that went through the largest sieve but did not go through the smallest sieve. Most of the very fine sand that goes through the #150 sieve will be removed by washing, and so should not be included in the sample for this analysis. Note that the results from analyzing this portion of sand will only be similar to the results after it is prepared by sieving and washing. This is because washing the sand may remove more or less very fine sand than what was removed through the #150 sieve.

Method

Sieve analysis is performed by shaking a sample of sand through a series of five screens with a catch pan at the bottom. Each sieve size is smaller than the one before so that, after 5 minutes of shaking the sieve set, the sand will either be retained on top of the sieves or passed through the sieves. The sieve sizes used in these instructions were specifically selected for analyzing sand for the biosand filter. This means that the sand should have already been sieved through a #24 screen to remove the coarse sand before taking the sample.

After measuring the amount of sand retained on each of the sieves, we calculate the percent of sand that passed through each sieve. A point is marked on a semi-log graph for the **Percent Passed Through the Sieve** for each sieve size. A line is then drawn on the graph connecting the five points. Using this line we can find the size that would allow 10% of the sand to pass through. This value is denoted as **d₁₀** and is called the **Effective Size (ES)** of the sand. Further up this same line we can find the size that 60%

of the sand would pass through. This value is denoted as **d60**. By dividing the d60 value by the d10 value we can determine the **Uniformity Coefficient (UC = d60/d10)** for that sand sample. These two values, the Effective Size and Uniformity Coefficient, are then compared to CAWST's recommended ranges for filtration sand. The Instructions describe this procedure in detail.

Using volume measurements rather than weight minimizes the equipment required while still providing adequate results for purposes of analyzing sand for biosand filters. Note that this is not an approved standard procedure but rather a workable field method for rapid assessment.

It is very important that the sand sample is totally dry before it is placed in the sieve set. Wet or damp sand often plugs the screens making it difficult to sieve and the results will be incorrect. Try to select the sand sample for sieve analysis so that it is representative of the sand you will be using.

Materials Required

- Sand sample: at least 100 ml of very dry sand for analysis (the sand sample must be representative of sand to be analyzed)
- Graduated cylinder: 100 ml size, with 1 ml markings, plastic is recommended
- Set of screens:
 - #24 sieve (opening size = 0.71 mm)
 - #40 sieve (opening size = 0.38 mm)
 - #60 sieve (opening size = 0.25 mm)
 - #80 sieve (opening size = 0.18 mm)
 - #150 sieve (opening size = 0.10 mm)
 - Catch pan (to catch all sand that passes #150 sieve)
 - Sieve set lid (placed above the #24 sieve to contain the sand while shaking)
- Semi-log graph paper (provided in this Appendix)
- Pencil (If the graph paper is laminated, then you can use an erasable pen so that the markings can be erased and the graph can be reused many times.)
- Ruler
- Calculator

Instructions to Analyze Prepared Sand

1. Stack the sand sieves with the coarsest (#24) on top followed by the #40, #60, #80, #150 and finally the catch pan on the bottom.
2. Fill the graduated cylinder to the 90 ml mark with the dry prepared sand sample. Use a piece of paper, rolled or folded, as a 'funnel' to make it easier to fill the graduated cylinder.
3. Pour the entire 90 ml sample from the graduated cylinder onto the top sieve (#24) and place the lid on top of the sieve.
4. Shake the entire sieve set, including the bottom catch pan and top lid, for at least 5 minutes. Shake both sideways and up and down to ensure the sand falls through the various screens.
5. After 5 minutes, remove the top lid and pour the sand from the #24 sieve into the graduated cylinder. Use a piece of paper as a funnel to help pour the sand into the

cylinder. Read the amount of sand in the graduated cylinder. **Do not pour out the sand from the cylinder afterwards.** In the table on the semi-log graph paper provided, record the value in the column; **Cumulative Sand Retained On the Sieve** for the #24 sieve. *Note: There should be very little or no sand on the #24 sieve since your sample should have already been sieved through the #24 sieve size to remove the coarse sand.*

6. Remove the next #40 sieve and pour the sand from it into the cylinder (on top of the sand from the #24 sieve), then read the total amount of sand in the cylinder. Record the value in the column; **Cumulative Sand Retained On the Sieve** for the #40 sieve.
7. Repeat Step 6 for the #60 sieve, then the #80 sieve, the #150 mesh, and finally the catch pan. Once all of these sieves (and catch pan) have been poured into the graduated cylinder, it should read approximately 90 ml. Some sand may have been lost in the shaking and the total may not add up to 90 ml. Try to avoid any sand loss by emptying the sieves thoroughly and lightly tapping the cylinder after each sieve to help settling.
8. Calculate the **Percent Retained On the Sieve** and the **Percent Passing Through the Sieve** for each sieve and record your results.

Example Sand Sieve Analysis

Sieve Size	Cumulative Sand Retained On the Sieve – Read From Graduated Cylinder (A)	Percent Retained On the Sieve (C=A/B*100)	Percent Passing Through the Sieve (100-C)
#24	0 ml	0 %	100 %
#40	17.1 ml	18.0 %	82.0 %
#60	72.9 ml	76.7 %	23.3 %
#80	87.8 ml	92.4 %	7.6 %
#150	94.6 ml	99.6 %	0.4 %
Catch pan	95 ml (B)	100 %	0 %

9. Plot the **Percent Passing Through the Sieve** value for each sieve size on the graph paper and then draw a line joining the 5 points as shown in the Example Worksheet. (Line starts at #24 sieve size and ends at #150 sieve size)

10. Determine the **Effective Size**. This is defined as the size opening that will just pass 10% of the sand (**d10** value). Read this value from the graph where the line crosses the Passing Through the Sieve line at 10%.

Recommended ES range = 0.15 mm to 0.20 mm (likely to achieve 0.4 L/minute flow rate in the biosand filter, also recommended for community slow sand filters)

11. Determine the **Uniformity Coefficient**. This is defined as a ratio and calculated as the size opening that will just pass 60% of the sand (**d60** value) divided by the size opening that will just pass 10% of the sand sample (the **d10** value). The Uniformity Coefficient is a measure of how well or poorly sorted the sand is.

Recommended UC range = 1.5 to 2.5 (likely to achieve 0.4 L/minute flow rate, also recommended for community slow sand filters)

12. Determine the **Percent Passing Through the #150 Sieve**. This is the measure of the very fine sand (also called rock flour) that can plug the filtration sand and cause turbid water to come out of the biosand filter. CAWST recommends that the sand is washed sufficiently so that **not more than 4%** of the sand will pass through the #150 sieve.

Recommended Value for Percent Passing Through the #150 Sieve = < 4%

Instructions to Determine % Rejected

To determine what percentage of a sand source will be too large to use as filtration sand:

1. Place only the #24 sieve on to the catch pan. Take a representative of a dry sand sample.
2. Fill the graduated cylinder with 100 ml of the dry sand sample.
3. Pour the entire 100 ml sample from the graduated cylinder onto the top sieve (#24) and place the lid on top of the sieve.
4. Shake the #24 sieve, including the bottom catch pan and top lid, for about 20 seconds. Shake both sideways and up and down to ensure the sand falls through the screen.
5. Remove the top lid and pour the sand from the #24 sieve into the graduated cylinder. Use a piece of paper as a funnel to help pour the sand into the cylinder. Read the amount of sand in the graduated cylinder. This value is the **% Rejected – Too Coarse**.
6. Empty the graduated cylinder and pour in the sand from the catch pan. Read the amount of sand in the graduated cylinder. This is the portion of the sand that will remain after sieving with the #24 screen. Note that this portion may have a considerable amount of very fine sand in it. To determine the amount of very fine sand, follow the previous instructions using all 5 sieves to determine the % passing through #150 sieve – this is approximately the **% Rejected – Too Fine** and will need to be removed by washing.

Example Sand Sieve Analysis

Sample Description: **Sample 11B - Sarcee sand - South Quarry, 14July09, D. Baker**

Sand Sieve Size	Cumulative Sand Retained On the Sieve, ml (A)	Percent Retained On the Sieve, % (C=A/B*100)	Percent Passing Through the Sieve, % (100-C)
#24	0.0	0.0%	100.0%
#40	17.1	18.0%	82.0%
#60	72.9	76.7%	23.3%
#80	87.8	92.4%	7.6%
#150	94.6	99.6%	0.4%
Catch pan	95.0 (B)	100.0%	0.0%

Effective Size (mm)
 $d_{10} = 0.20$ Recommend 0.15 to 0.20 mm

Uniformity Coefficient:
 $d_{60}/d_{10} = 0.32/0.20 = 1.6$ Recommend 1.5 to 2.5

Very fine sand percent:
 % Passing #150 = 0.4% Recommend less than 4%

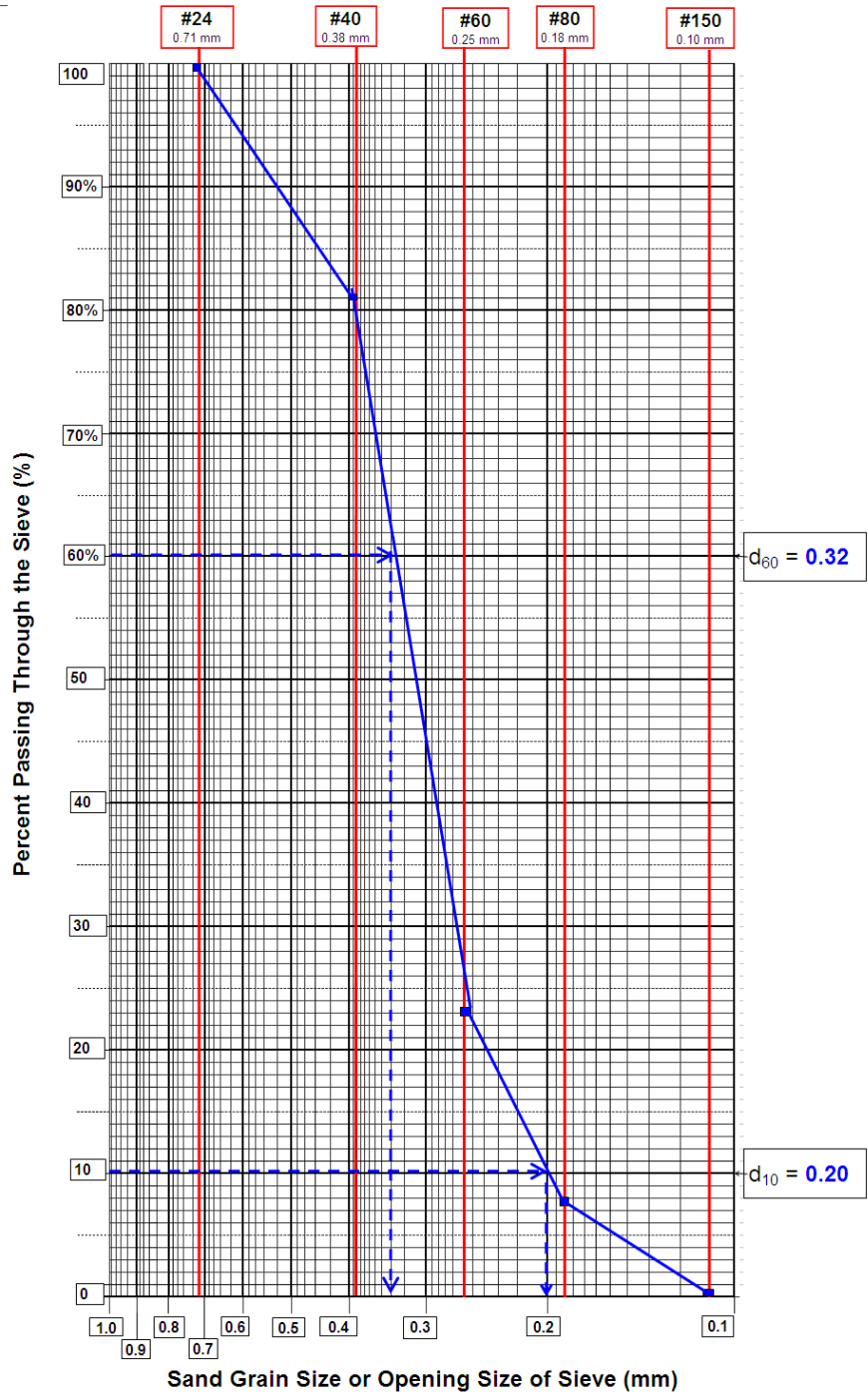

Sand Sieve Analysis

Sample Description:

Sand Sieve Size	Cumulative Sand Retained On the Sieve, ml (A)	Percent Retained On the Sieve, % (C=A/B*100)	Percent Passing Through the Sieve, % (100-C)
#24			
#40			
#60			
#80			
#150			
Catch pan	(B)		

Effective Size:

$d_{10} =$

Recommend 0.15 to 0.20 mm

Uniformity Coefficient:

$d_{60} / d_{10} =$

Recommend 1.5 to 2.5

Very fine sand percent:

% Passing #150 =

Recommend less than 4%

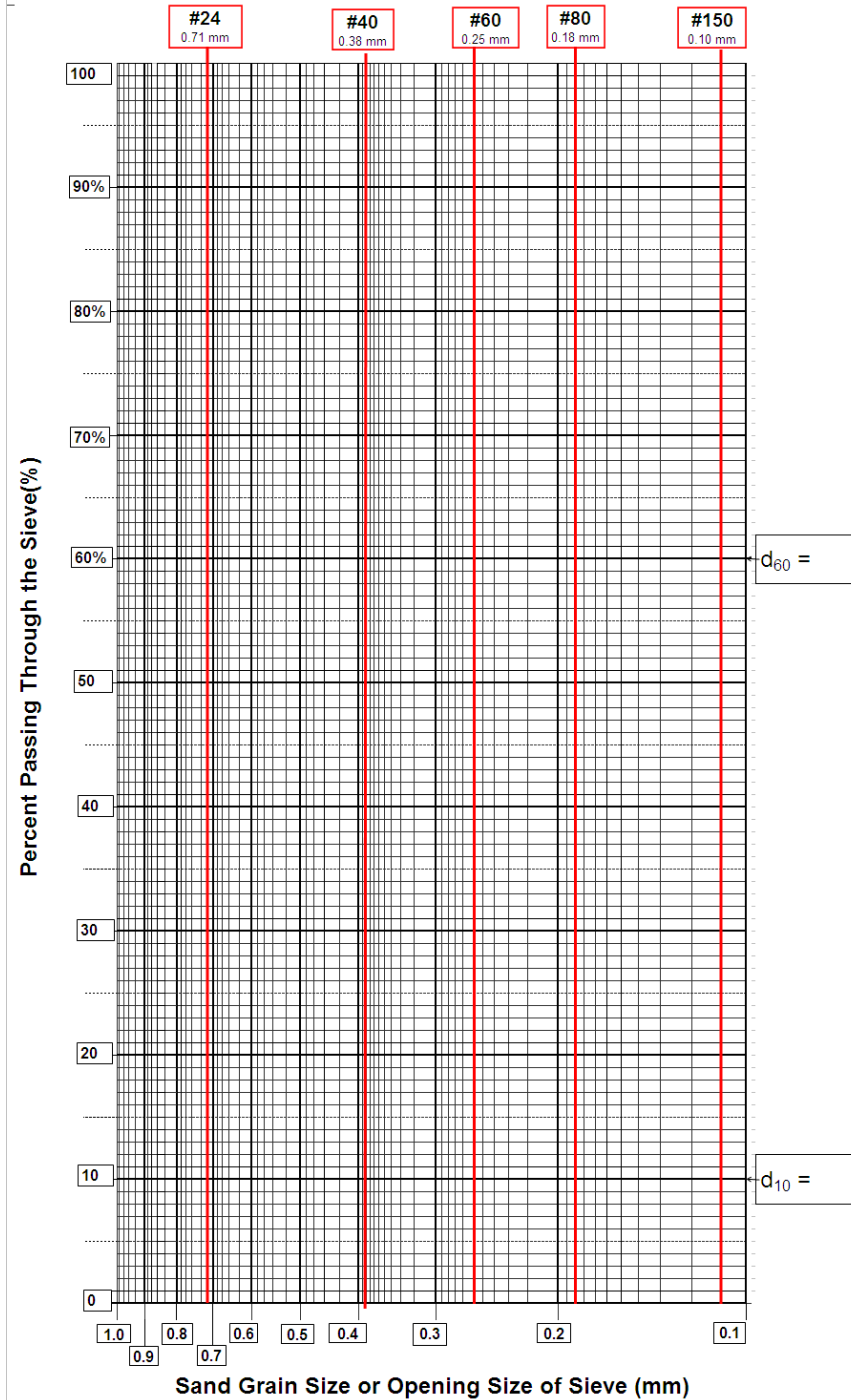

Appendix 4: Manufacturing and Installation Monitoring Forms

Biosand Filter Manual

Biosand Filter Manufacturing Checklist

Concrete Filter Box Construction

- The steel mold used was in good condition.
- The filter has been made with quality cement sand and gravel with a ratio of:
1 part cement : 2 parts sand (1 mm) : 1 part gravel (6 mm) : 1 part gravel (12 mm)
- The body has been filled with water and cured for 5-7 days.
- There are no leaks or cracks in the concrete filter box.
- The outlet tube is not plugged.
- The water level in the filter is below the diffuser.
- The filter is marked with an identifying number or code.

Diffuser and Lid

- There is a lid which covers the entire filter reservoir.
- The diffuser plate fits correctly without leaving gaps around the edge for water to pass.
- The holes in the diffuser plate are 3 mm (1/8") or smaller.

Filtration Sand Quality Control

- The sand sieves are in good condition, with no large holes or rips in the screen.
- The prepared sand is clean (containing no visible organic material).
- The prepared sand stored properly to prevent contamination.

Record Keeping

- The date of construction, materials used and details of units produced are recorded.
- Any cracked, broken or unusable filters are recorded.

Notes/Comments:

Biosand Filter Manufacturing Checklist – Reference Guide

Quality of Construction

1. The mold should be clean and free from defects. If there are any defect the mold should be repaired.
2. The concrete mix ratios should be used for all filters. The mix is by volume, not by weight.
3. All filters should be filled with water after they have been demolded and left to cure for a minimum of 5-7 days before they are checked and distributed.
4. With the filter full of water, check to see if there are any leaks. Any leaks found should be repaired. If cracks are very large the filter should be rejected.
5. Fill the filters to the very top with water (without any sand in the filter) and measure the flow rate. It should take less than 1 minute to fill a 1 litre container. If it takes longer than 1 minute, the tube may be blocked with some concrete or other debris which needs to be cleared before the filter is installed.
6. Wait until the water stops flowing out of the outlet tube. At that point, the water level inside the filter should be below the concrete ledge where the diffuser sits. If above this level the outlet tube may be blocked or the outlet tube may be too short
7. This number or code will allow the filter to be tracked from construction through to installation and use in the home.

Diffuser and Lid

8. Tightly fitting lid prevents contamination of water and unwanted pests
9. Required to prevent the disturbance of the sand and to protect the biological layer when water is poured in.
10. Holes in the diffuser plate should be 3 mm (1/8") or smaller to prevent disturbance of the sand and to protect the biological layer.

Filtration Sand Quality Control

The sand used inside the filter is really important because it's what cleans the water. If the sand being used is not suitable, a new source will need to be found.

11. The sieves that are used for preparing sand should have holes that are 0.7 mm or smaller. If the screen has any holes, or if the wires of the screen have moved apart (leaving holes that are bigger than 0.7 mm), the screen needs to be replaced.
12. Sand containing organic material (small pieces of leaves, roots or sticks) must not be used as this will provide food for microorganisms to grow in the filter. Crushed rock is preferred because it usually doesn't contain any organic material. River sand can be used, but it should be cleaned thoroughly so that all organic material is removed.
13. Once the sand is clean, it should be stored in a way that keeps it clean. It can be covered with a tarp to prevent leaves and bird droppings from contaminating the sand. Also, no animals should be able to get into the clean sand.

Record Keeping

14. This information is important to ensure that the manufacturer is paying attention to quality control. It also helps the project manager understand the materials required for each filter and to ensuring all materials are accounted for.
15. This information allows the project manager to identify the percentage of filters being rejected and understand if there are manufacturing problems.

Biosand Filter Manufacturing Monitoring Form

Date _____ **Mold No.** _____

Your Name _____ **Filter No.** _____

Concrete Body Construction

1. The mold used was in good condition..... True False
2. The filter has been made with quality cement sand and gravel with a ratio of 1 cement : 2 sand : 1 gravel (6 mm) : 1 gravel (12 mm)..... True False
3. The body has been filled with water and cured for 5-7 days..... True False
4. There are no leaks or cracks in the concrete filter bodies..... True False
5. The outlet tube is not plugged with any debris..... True False
6. The water level in the filter is below the diffuser plate..... True False
7. The filter is marked with an identifying number or code True False

Diffuser and Lid

8. There is a lid which covers the entire opening of the filter..... True False
9. The diffuser plate fits correctly without leaving gaps around the edge for water to pass True False
10. The holes in the diffuser plate are 3 mm (1/8”) or smaller..... True False

Filtration Sand Quality Control

11. The sand sieves are in good condition, with all holes smaller than 1mm True False
12. The prepared sand is clean (containing no visible organic material) True False
13. The prepared sand stored properly to prevent contamination..... True False

Record Keeping

14. The date of construction, materials used and details of units produced are recorded True False
15. Any cracked, broken or unusable filters or materials are recorded.. True False

ALL POINTS MARKED “FALSE” SHOULD BE RECTIFIED

Notes/Comments:

Biosand Filter

Manufacturing Monitoring Form – Reference Guide

Quality of Construction

1. The mold should be clean and free from defects. If there are any defect the mold should be repaired.
2. The concrete mix ratios should be used for all filters. The mix is by volume, not by weight.
3. All filters should be filled with water after they have been demolded and left to cure for a minimum of 5-7 days before they are checked and distributed.
4. With the filter full of water, check to see if there are any leaks. Any leaks found should be repaired. If cracks are very large the filter should be rejected.
5. Fill the filters to the very top with water (without any sand in the filter) and measure the flow rate. It should take less than 1 minute to fill a 1 litre container. If it takes longer than 1 minute, the tube may be blocked with some concrete or other debris which needs to be cleared before the filter is installed.
6. Wait until the water stops flowing out of the outlet tube. At that point, the water level inside the filter should be below the concrete ledge where the diffuser sits. If above this level the outlet tube may be blocked or the outlet tube may be too short
7. This number or code will allow the filter to be tracked from construction through to installation and use in the home.

Diffuser Plate and Lid

8. Tightly fitting lid prevents contamination of water and unwanted pests
9. Required to prevent the disturbance of the sand and to protect the biological layer when water is poured in.
10. Holes in the diffuser plate should be 3 mm (1/8") or smaller to prevent disturbance of the sand and to protect the biological layer.

Sand Media Quality Control

The sand used inside the filter is really important because it's what cleans the water. If the sand being used is not suitable, a new source will need to be found.

11. The sieves that are used for preparing sand should have holes that are 0.7mm or smaller. If the screen has any holes, or if the wires of the screen have moved apart (leaving holes that are bigger than 0.7mm), the screen needs to be replaced.
12. Sand containing organic material (small pieces of leaves, roots or sticks) must not be used as this will provide food for microorganisms to grow in the filter. Crushed rock is preferred because it usually doesn't contain any organic material. River sand can be used, but it should be cleaned thoroughly so that all organic material is removed.
13. Once the sand is clean, it should be stored in a way that keeps it clean. It can be covered with a tarp to prevent leaves and bird droppings from contaminating the sand. Also, no animals should be able to get into the clean sand.

Record Keeping

14. This information is important to ensure that the manufacturer is paying attention to quality control. It also helps the project manager understand the materials required for each filter and to ensuring all materials are accounted for.
15. This information allows the project manager to identify the percentage of filters being rejected and understand if there are manufacturing problems.

Biosand Filter Manufacturing Monitoring Form

Date poured	Demold Date	Filter Number	Mold Number	Number of days cured	Flow Rate	Filter free of defects (Y/N)	Water level below diffuser (Y/N)	Mold free of defects (Y/N)	For use (Y/N)	Comments	Initials

Biosand Filter Installation Checklist

Quality of Construction

- There are no leaks on the concrete filter body
- There lid is free from damage and covers the entire opening of the filter
- The diffuser plate is free of damage and fits correctly without leaving gaps around the edge for water to pass

Proper Installation

- The filter is level
- The filter is in a suitable location away from weather and animals
- The sand and gravel was installed by adding them to water in the filter
- The surface of the sand is flat and level
- The depth of the water above the sand is 5 cm
- The flow rate of the filter is less than 0.4 litres/minute
- The user has been given a container for safe water storage

Training Provided to User

- The use and maintenance of the filter has been explained to the user
- The swirl and dump maintenance procedure has been demonstrated to the user
- The user has received an instructional poster/brochure/sticker

Collection of Payment

- Payment has been collected from the user and a receipt given

Record Keeping

- The names of recipients and date of delivery are recorded
- Payments made by users are recorded

Notes/comments:

Biosand Filter Installation Checklist – Reference Guide

Quality of Construction

1. If the filter is leaking, notify the manufacturer so they can fix it.
2. If the lid is damaged or does not fit, use another one and notify the manufacturer.
3. If the diffuser is damaged or does not fit, use another one and notify the manufacturer.

Proper Installation

4. If the filter is not level, make it level before proceeding further.
5. The filter should be inside the house or at least under a roof. If the filter needs to be moved, the manufacturer will have to re-install it.
6. If sand is placed before the water this will trap air bubbles in the filter. The filter should be reinstalled if this happens.
7. It is essential that the sand surface is leveled after installation. If the sand is not flat and level, the biological layer will not grow evenly.
8. The water depth should be 5cm above the sand. If it is more than 5cm, add more sand. If it is less than 3cm, remove some sand.

9. With the filter completely full of water, the flow rate should be less than 0.6L/minute (which means it should take 100 seconds to fill a 1 Litre bottle).

NOTE This is an absolute maximum and the target flow rate is 0.4L/minute (which means it should take 150 seconds to fill a 1 Litre bottle)

- If the flow rate is faster, the filter will not work properly. The filter should be reinstalled and the manufacturer notified.

- If the flow rate is slower, the filter is still working fine. However, if you think the flow rate is too slow and inconvenient, a swirl and dump maintenance should be done. The filter should be reinstalled and the manufacturer notified.

10. Each user should receive a safe storage container to ensure the filtered water does not become re-contaminated. The storage container should prevent people's hands, cups, or dippers from touching the water and be easy to clean.

Training Provided to User

11. The user should receive a full explanation of the use and maintenance of the filter and should be able to repeat back to the installer the information given.
12. The procedure should be demonstrated and where possible practiced by the user.
13. Any printed information available should be left with the user to help them remember the important parts of their use and maintenance training.

Collection of Payment

14. A receipt should be given to the user for their payment to the filter. This prevents the loss of any money and prevents future disputes.

Record Keeping

15. This allows each filter to be tracked and may help resolve any future problems with the filter.
16. This enables the tracking of all monies received and prevents money from being lost.

Biosand Filter Installation Monitoring Form

Date _____ **Location** _____

Your Name _____ **Name of Household** _____

Quality of Construction

- 1. There are no leaks on the concrete filter body..... True False
- 2. There lid is free from damage and covers the entire opening of the filter
..... True False
- 3. The diffuser plate is free of damage and fits correctly without leaving gaps around the
edge for water to pass True False

Proper Installation

- 4. The filter is level..... True False
- 5. The filter is in a suitable location away from weather and animals... True False
- 6. The sand and gravel was installed by adding them to water in the filter
..... True False
- 7. The surface of the sand is flat and level.....True False
- 8. The depth of the water above the sand is 5 cm..... True False
- 9. The flow rate of the filter is less than 0.4 litres/minute True False
- 10. The user has been given a container for safe water storage..... True False

Training Provided to User

- 11. The use and maintenance of the filter has been explained to the user
..... True False
- 12. The swirl and dump maintenance procedure has been demonstrated to the user
..... True False
- 13. The user has received an instructional poster/brochure/sticker..... True False

Collection of Payment

- 14. Payment has been collected from the user and a receipt given True False

Record Keeping

- 15. The names of recipients and date of delivery are recorded..... True False
- 16. Payments made by users are recorded..... True False

*ALL POINTS SHOULD BE MARKED "TRUE" BEFORE COMPLETING THE
INSTALLATION*

Notes/Comments:

Biosand Filter

Installation Monitoring Form – Reference Guide

Quality of Construction

1. If the filter is leaking, notify the manufacturer so they can fix it.
2. If the lid is damaged or does not fit, use another one and notify the manufacturer.
3. If the diffuser is damaged or does not fit, use another one and notify the manufacturer.

Proper Installation

4. If the filter is not level, make it level before proceeding further.
5. The filter should be inside the house or at least under a roof. If the filter needs to be moved, the manufacturer will have to re-install it.
6. If sand is placed before the water this will trap air bubbles in the filter. The filter should be reinstalled if this happens.
7. It is essential that the sand surface is leveled after installation. If the sand is not flat and level, the biological layer will not grow evenly.
8. The water depth should be 5cm above the sand. If it is more than 5cm, add more sand. If it is less than 3cm, remove some sand.
9. With the filter completely full of water, the flow rate should be less than 0.4 litres/minute. If the flow rate is faster, the filter will not work properly. The filter should be reinstalled and the manufacturer notified. If the flow rate is slower, the filter is still working fine. However, if you think the flow rate is too slow and inconvenient, a swirl and dump maintenance should be done. The filter should be reinstalled and the manufacturer notified.
10. Each user should receive a safe storage container to ensure the filtered water does not become re-contaminated. The storage container should prevent people's hands, cups, or dippers from touching the water and be easy to clean.

Training Provided to User

11. The user should receive a full explanation of the use and maintenance of the filter and should be able to repeat back to the installer the information given.
12. The procedure should be demonstrated and where possible practiced by the user.
13. Any printed information available should be left with the user to help them remember the important parts of their use and maintenance training.

Collection of Payment

14. A receipt should be given to the user for their payment to the filter. This prevents the loss of any money and prevents future disputes.

Record Keeping

15. This allows each filter to be tracked and may help resolve any future problems with the filter.
16. This enables the tracking of all monies received and prevents money from being lost.

Appendix 5: Follow Up Visit Monitoring Forms

Biosand Filter Manual

Biosand Filter Follow Up Visit Checklist

Quality of Construction

- There are no leaks on the concrete filter body
- There is a lid which covers the entire opening of the filter
- There is the original diffuser plate without cracks or damage

Proper Installation

- The filter is in a suitable location away from weather and animals
- The surface of the sand flat and level
- The depth of the water above the sand is between 4 and 6 cm
- The flow rate of the filter is less than 0.4 litres/minute
- The water does not have a bad taste or odour

Proper Use

- There is not a valve or tube attached to the outlet of the filter
- The outlet spout of the filter is clean
- The filter is being used every 1 or 2 days

Safe Water Storage

- The treated water storage container has a lid
- The storage container has a narrow opening/ tap to get water out
- The storage container appears clean (free of dirt and algae)
- The user has different containers for collecting and storing water)

Record Keeping

- The name of the household visited, problems and comments are recorded
- Any problems found which need further action are entered into the problem log

Biosand Filter

Follow Up Visit Checklist – Reference Guide

Quality of Construction

1. If the filter is leaking, notify the manufacturer so they can fix it.
2. If the lid is missing or damaged, either the user or the manufacturer can replace it.
3. If the diffuser is damaged, notify the manufacturer so they can replace it.

Proper Installation

4. The filter should be inside the house or at least under a roof. If the filter needs to be moved, the manufacturer will have to re-install it.
5. If the sand is not flat and level, the diffuser plate may not be working. If the sand looks like it has been pushed away from the concrete walls, the water may be running around the edges of diffuser plate and the diffuser plate may need to be replaced.
6. The water depth should be 5cm above the sand. If it is less than 4cm or more than 6cm, notify the manufacturer so that they can fix it.
7. With the filter completely full of water, the flow rate should be less than 0.4 litres/minute. If the flow rate is faster, the filter will not work properly. Notify the manufacturer so they can fix it. If the flow rate is slower, the filter is still working fine. However, if the user thinks the flow rate is too slow and inconvenient, a swirl and dump maintenance can be done to increase the flow. The user can do the maintenance themselves. If the user doesn't remember how, notify the person responsible for training users, so they can remind the user.
8. If the treated water has a bad taste or odour, the filter may not be working well, so notify the manufacturer.

Proper Use

9. Valves or tubes must be removed from the outlet or else the filter will not work properly.
10. The outlet should not have any dirt or algae on it and should be cleaned regularly. If it is dirty advise the user that regular cleaning is required.
11. The filter must be used every day or two for it to work properly. If it is not being used regularly, instruct the user on the need to use their filter every one or two days and notify the person who is responsible for training users so they can do a follow-up visit.

Safe Water Storage

12. The storage container should be closed to prevent people's hands, cups, or dippers from touching the water. If an unsuitable storage container (such as a bucket with no lid) is being used, notify the person responsible for training users.
13. There should be an easy way to get the water out of the container without dipping. If an unsuitable storage container (such as a bucket with no lid) is being used, notify the person responsible for training users.
14. The storage container should have no dirt or algae in or on it. If it is not clean the user should be advised on the need to keep the container clean.
15. The user must use different containers for collecting water and for storing water, so that they do not contaminate their treated water. If they are not using different containers, advise them that they should use separate containers and notify the person responsible for training users.

Record Keeping

16. These records will provide valuable information for future visits and help with resolving any problems.
17. This will allow the project manager to ensure all problems are resolved.

Biosand Filter Follow Up Visit Monitoring Form

Date _____ Location _____

Your Name _____ Name of Household _____

Quality of Construction

1. There are no leaks on the concrete filter body
2. There is a lid which covers the entire opening of the filter
3. There is the original diffuser plate without cracks or damage

Proper Installation

4. The filter is in a suitable location away from weather and animals
5. The surface of the sand flat and level
6. The depth of the water above the sand is between 4 and 6 cm
7. The flow rate of the filter is less than 0.4 litres/minute
8. The water does not have a bad taste or odour

Proper Use

10. There is not a valve or tube attached to the outlet of the filter
11. The outlet spout of the filter is clean
12. The filter is being used every 1 or 2 days

Safe Water Storage

13. The treated water storage container has a lid
14. The storage container has a narrow opening/ tap to get water out
15. The storage container appears clean (free of dirt and algae)
16. The user has different containers for collecting and storing water)

Record Keeping

17. The name of the household visited, problems and comments are recorded
18. Any problems found which need further action are entered into the problem log

Notes/Comments:

Biosand Filter

Follow Up Visit Monitoring Form – Reference Guide

Quality of Construction

1. If the filter is leaking, notify the manufacturer so they can fix it.
2. If the lid is missing or damaged, either the user or the manufacturer can replace it.
3. If the diffuser is damaged, notify the manufacturer so they can replace it.

Proper Installation

4. The filter should be inside the house or at least under a roof. If the filter needs to be moved, the manufacturer will have to re-install it.
5. If the sand is not flat and level, the diffuser plate may not be working. If the sand looks like it has been pushed away from the concrete walls, the water may be running around the edges of diffuser plate and the diffuser plate may need to be replaced.
6. The water depth should be 5cm above the sand. If it is less than 4cm or more than 6cm, notify the manufacturer so that they can fix it.
7. With the filter completely full of water, the flow rate should be less than 0.4 litres/minute. If the flow rate is faster, the filter will not work properly. The filter should be reinstalled and the manufacturer notified. If the flow rate is slower, the filter is still working fine. However, if you think the flow rate is too slow and inconvenient, a swirl and dump maintenance should be done. The filter should be reinstalled and the manufacturer notified.
8. If the treated water has a bad taste or odour, the filter may not be working well, so notify the manufacturer.

Proper Use

9. Valves or tubes must be removed from the outlet or else the filter will not work properly.
10. The outlet should not have any dirt or algae on it and should be cleaned regularly. If it is dirty advise the user that regular cleaning is required.
11. The filter must be used every day or two for it to work properly. If it is not being used regularly, instruct the user on the need to use their filter every one or two days and notify the person who is responsible for training users so they can do a follow-up visit.

Safe Water Storage

12. The storage container should be closed to prevent people's hands, cups, or dippers from touching the water. If an unsuitable storage container (such as a bucket with no lid) is being used, notify the person responsible for training users.
13. There should be an easy way to get the water out of the container without dipping. If an unsuitable storage container (such as a bucket with no lid) is being used, notify the person responsible for training users.
14. The storage container should have no dirt or algae in or on it. If it is not clean the user should be advised on the need to keep the container clean.
15. The user must use different containers for collecting water and for storing water, so that they do not contaminate their treated water. If they are not using different containers, advise them that they should use separate containers and notify the person responsible for training users.

Record Keeping

16. These records will provide valuable information for future visits and help with resolving any problems.
17. This will allow the project manager to ensure all problems are resolved.

Appendix 6: Costing and Pricing Forms

Biosand Filter Manual

BIOSAND FILTER COSTING AND PRICING FORM <i>For Internal Use Only</i>				
Description of Material	Quantity Used	Price per Unit	Cost of Quantity Used	
Travel Time to pick up materials				
Direct Materials Used - Total Cost			→	
Direct Labour Costs	Hours	Cost per Hour	Subtotal	
Filter Fabrication				
Filter Installation				
Direct Labour – Total Cost			→	
Total Direct Costs				
Overhead (%)				
Total Indirect Costs				
Profit Margin (%)				
PRODUCT PRICE Before Delivery				
Delivery to customer location				
FINAL DELIVERED AND INSTALLED PRODUCT PRICE				

Biosand Filter Manual

BIOSAND FILTER COSTING AND PRICING FORM

Materials Used	Quantity Purchased	Cost of Purchases	Quantity Used	Cost Per Filter
Total cost of materials used:				

Labour Costs	Cost Per Filter
Total Labor Costs:	

Transport Costs	Cost Per Filter
Total transport costs:	

TOTALS	
Total direct costs (materials, labor, transport)	
Profit Margin (% of direct costs):	
Overhead costs (% of direct costs):	

PRICE OF FILTER:	
-------------------------	--

Biosand Filter Manual