



CURRENT PRODUCT OFFERINGS





About Drip Irrigation. 5

Micro-tube

20 square meters 7
 100 square meters. 11
 200 square meters 15
 500 square meters. 19

Inline Drip Irrigation

200 square meter. 23
 500 square meters. 27
 Toro 500 square meters. 31
 1000 square meters. 34

Mini Sprinklers. 37

Pumps

EcoFlo 40
 Saaji Pressure Treadle 42
 SkI Mobile. 43

Water Bags

25 Liters. 45
 200 Liters. 46
 1,000 Liters. 47

iDEal - Global Supply
www.ideorg.org
globalsupply@ideorg.org

GLOBAL SUPPLY INITIATIVE

Global Supply is an initiative within iDE responsible for the supply and technical support of affordable, simple, and appropriate micro-irrigation technologies worldwide. This is done through iDE's social enterprise subsidiary, iDEal. These products are used by small-scale farmers in developing countries to improve water lifting, storage, and application techniques.

CURRENT PRODUCT OFFERINGS

Technical Services

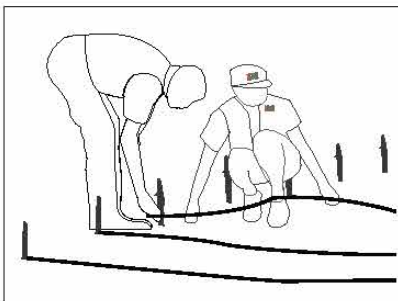

Correct utilization of micro-irrigation systems can make a dramatic impact in crop yield. Through our extensive global network of irrigation engineers and agriculture experts, we offer consulting services for technical support, system design and installation training. By leveraging our international staff we offer consulting arrangements for field assessments, irrigation planning and product installation. For more information on these services please contact Global Supply directly.

Micro-tube Drip Irrigation Kits



20 sqm Micro-tube Drip Kit
with Water Bag

100 sqm Micro-tube Drip Kit

200 sqm Micro-tube Drip Kit

500 sqm Micro-tube Drip Kit

Inline Drip Irrigation Kits

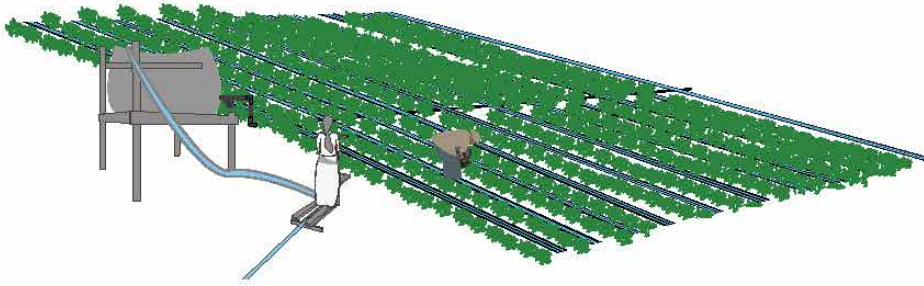

200 sqm Inline Drip Kit

Toro 500 sqm Inline Drip Kit

500 sqm Inline Drip Kit

1000 sqm Inline Drip Kit

Mini Sprinkler Kits

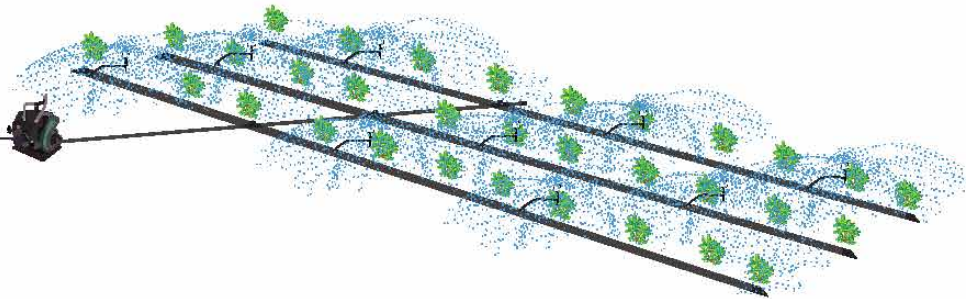

500 sqm Mini Sprinkler Irrigation Kit

1000 sqm Mini Sprinkler Irrigation Kit

Pressure Treadle Pumps

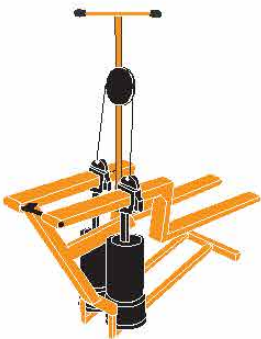

EcoFlo Mobile Pressure Treadle Pump Kit

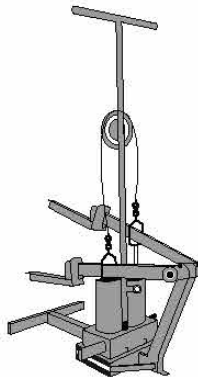

SKI Mobile Pressure Treadle Pump Kit



Saajhi Pressure Treadle Pump

Water Bags

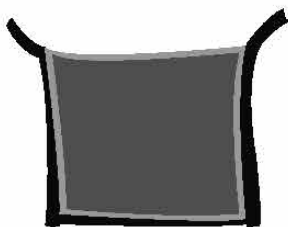

25 Liter Water Bag

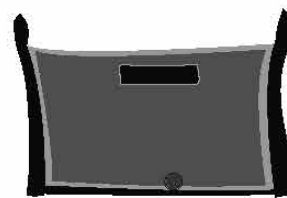

200 Liter Water Bag



1,000 Liter Water Bag

New Products in Development

- Motorized Water Pumps
- Self-supporting 1,000 Liter Water Bag
- Custom Designed Drip Irrigation System



WATER APPLICATION MICRO-IRRIGATION DRIP SYSTEMS



Drip irrigation systems bring water efficiently and uniformly to the roots of high value crops and trees. These gravity-fed systems are designed to work effectively with very low pressure, minimizing the effort and energy needed to irrigate.

These kits are designed to operate with water storage bags as low as .75 meters above the crop with pressures as low as .75 bar (1 PSI).

iDEaL PROMOTES TWO TYPES OF DRIP IRRIGATION SYSTEMS; MICRO-TUBE AND INLINE SYSTEMS.

MICRO-TUBES:

Designed for small to medium sized plots. This system utilizes small diameter micro-tubes which are inserted into each lateral line. Each kit comes with pre-punched sub-main lines spaced in 1 meter increments. Emitter spacing is decided by the user and requires the user to punch holes and install the micro-tube.

iDEaL for 20-500sqm size

- Lower cost than inline
- Lower filtration requirement.
- Components are easy to repair and replace.

INLINE:

Designed for larger sized plots. This system utilize an inline emitter, which is integrated into the lateral line. Spacing for each emitter is predetermined at 30cm. These kits have more flexibility in the layout and overall system size.

iDEaL for 200sqm-1000sqm

- Simpler and faster to install then the micro-tube system
- Improved water application uniformity
- Longer laterals can be run
- Greater versatility in system layout and sizing

Kits	Plot Size (meters)	Number of Micro-tubes	Water Required per Hour*
MICRO-TUBE DRIP IRRIGATION OPTIONS			
20m ²	4 x 5	80	480 liters
100m ²	10 x 10	360	2,160 liters
200m ²	10 x 20	730	4,380 liters
500m ²	20 x 25	1,750	10,500 liters

* Assumes all micro-tubes are present and 1 meter head of pressure

Kits	Plot Size (meters)	Number of inline emitters spaced every 30cm	Water Required per Hour*
INLINE DRIP IRRIGATION OPTIONS			
200m ²	10 x 20	660	660 liters
500m ²	25 x 20	1,500	1,500 liters
Toro 500m ²	25 x 20	See Product Sheet page 31	
1,000m ²	30 x 33	3,000	3,000 liters

* Assumes 1 meter head of pressure



20 SQUARE METER MICRO-TUBE DRIP KIT

PRODUCED BY: HARVEL AZUD, INDIA

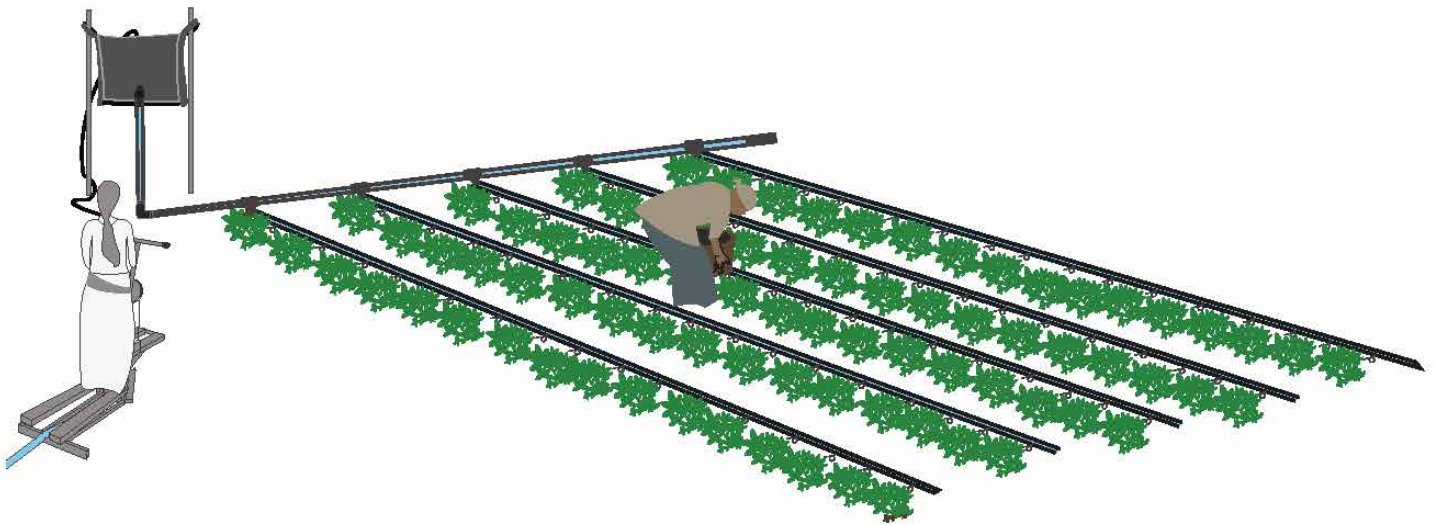

Product Configuration

Plot Size	4 x 5 meter (pre-configured)
Row Spacing	1 meter
Microtube Emitter Spacing	30cm typical (determined by user)
Number of Laterals	5
Recommended Configuration	Sub-main located at top of field (pre-configured)
Recommended Water Storage	25 liter water bag (included in kit)
Emitter Flow Rate	6 liter/hour (at 1 meter head)
Pressure Operating Range	0.75-3 meter head (0.075 to 0.3 bar)
System Uniformity	80-85%

Package and Weight



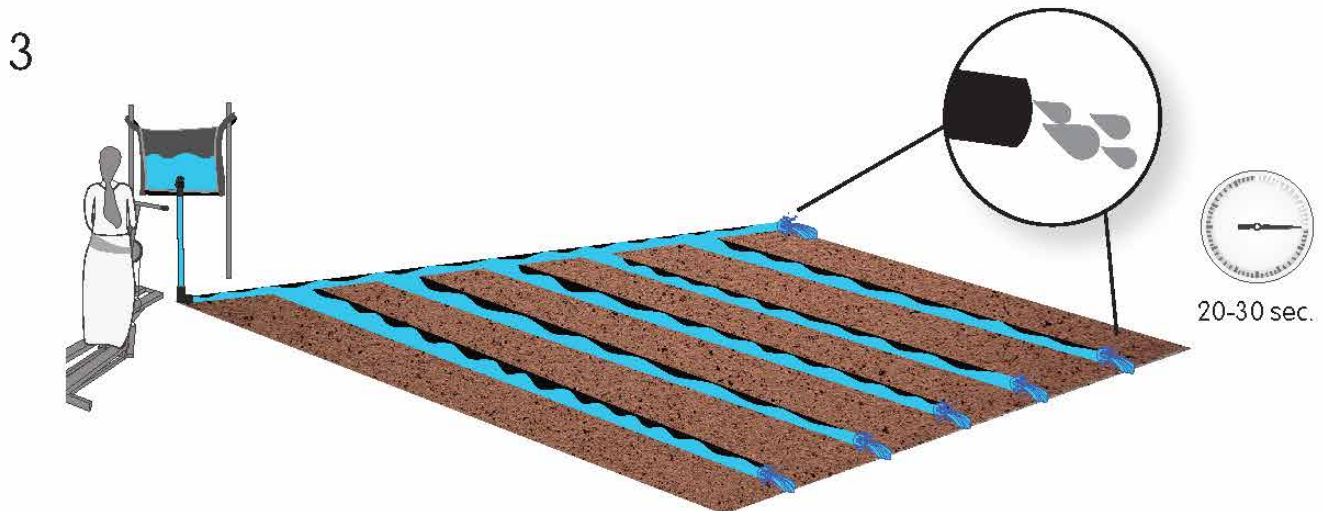
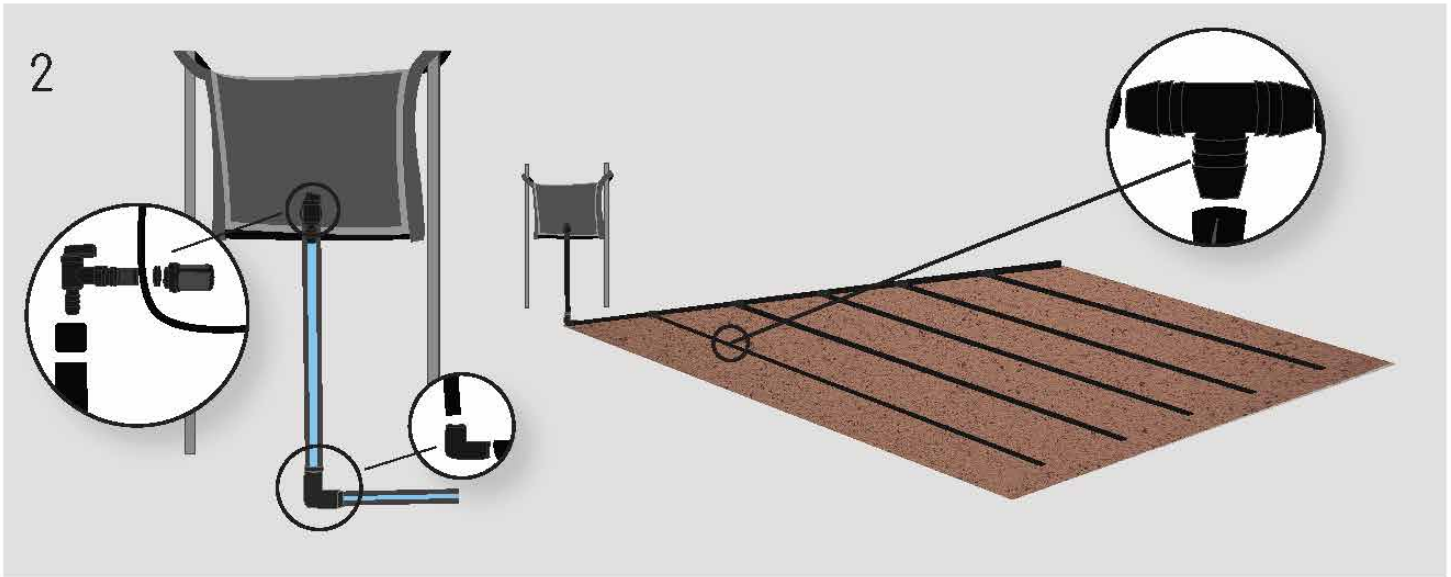
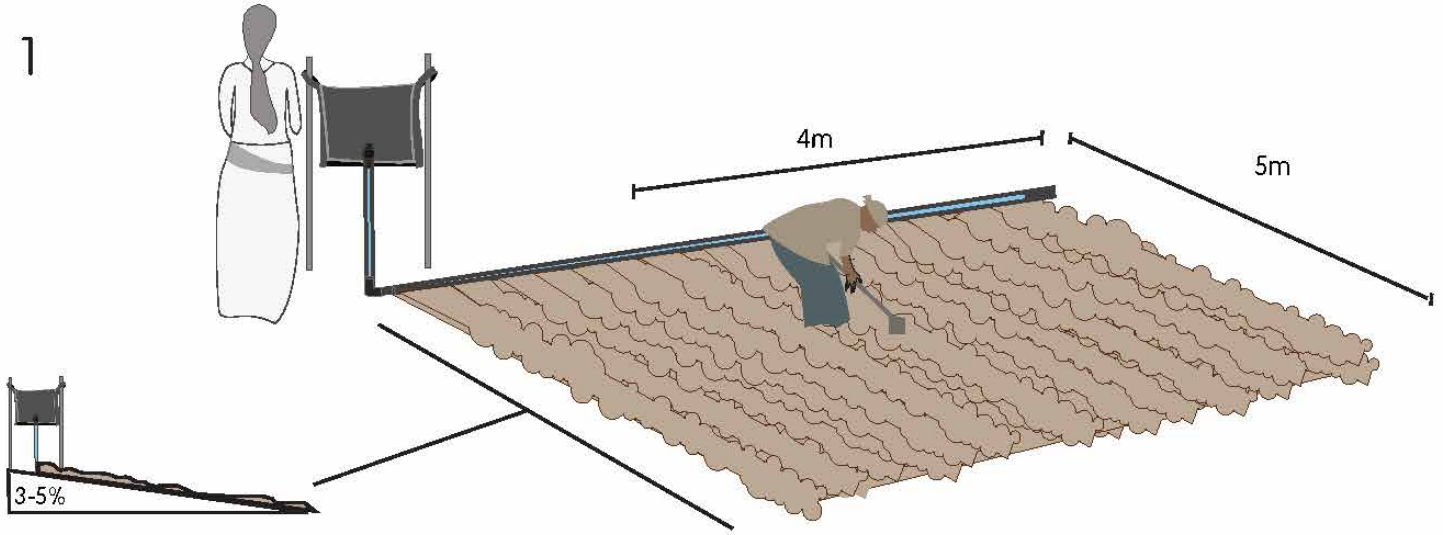

Package	Plastic Bag in Cardboard Box
Package Size	30 x 38 x 51cm
Package Volume	0.005m ³
Gross Weight	0.6 kg

Picture	Item	Quantity	Technical Specifications
BILL OF MATERIAL			
	25 Liter Water Bag	1	Inner liner wall thickness: 200 micron
	Inside Filter	1	16mm diameter, 100 Mesh (non corrosive)
	Main Pipe	3 meters	16mm diameter rigid pipe
	Tank Connector	1	
	Elbow	4	16mm, to connect the Main Pipe sections
	Lay-Flat Sub-Main Pipe	3 meters	200 micron, 16mm diameter
	Lay-Flat Laterals	5 x 5 meters	200 micron, 16mm diameter
	Microtube	80	1.2mm x 20cm
	Take-Off Tees	4	16mm
	Rigid Sleeves	14	16mm to be used to connect laterals and sub-main to the Take-Off Tees
SPARES AND TOOLS			
	Joiners	1	16mm
	Lay-Flat Lateral	1 x 5 meters	200 micron, 16mm diameter
	Rigid Sleeve	2	16mm to be used to connect laterals and sub-main to the Take-Off Tees
	Lay-Flat Sleeve	10	200 micron, 16mm diameter, 1cm, for end of laterals
	Lateral/Thumb Punch	2	To punch holes into the laterals
	Microtubes	10	1.2mm x 20cm

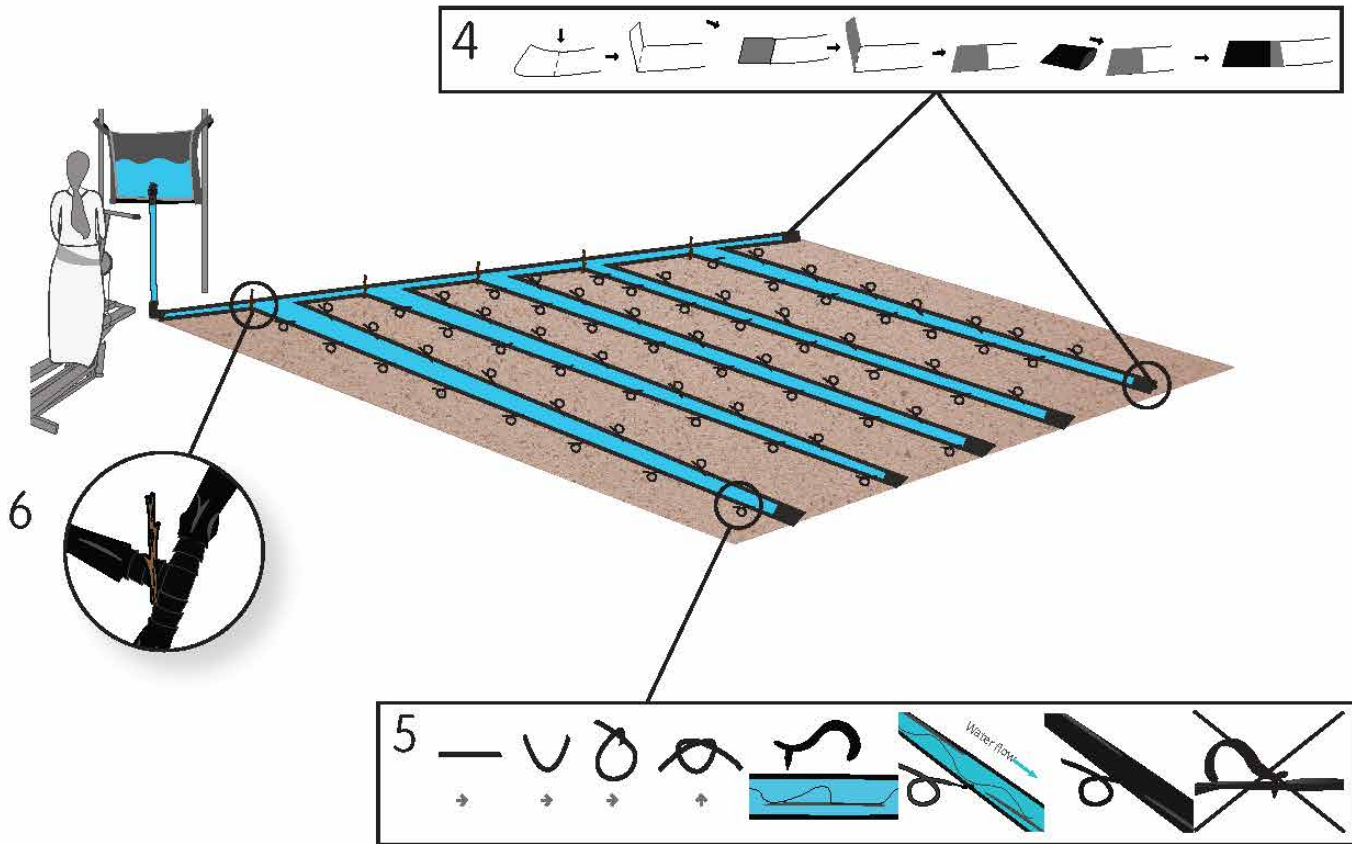
INSTALLATION GUIDE - 20 SQM

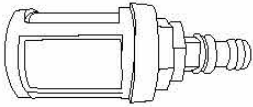

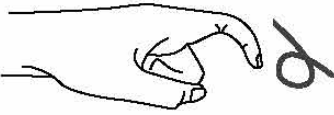

MAINTENANCE			
	Clean filter regularly.		Periodically flush sub main and laterals by opening end caps and running water through the system.
TROUBLE SHOOTING			
	If micro tube is clogged, remove microtube from lateral. Flick tube or blow through tube to remove debris. Re-insert into lateral.		If there is a leak or large cut in lateral, cut damaged section. Connect two pieces with a joiner.



100 SQUARE METER MICRO-TUBE DRIP KIT

PRODUCED BY: HARVEL AZUD, INDIA













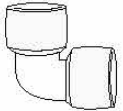



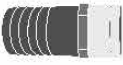





Product Configuration



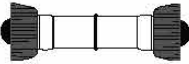

Plot Size	10 x 10 meter (pre-configured)
Row Spacing	1 meter
Microtube Emitter Spacing	30cm typical (determined by user)
Number of Laterals	11
Recommended Configuration	Sub-main located at top of field (pre-configured)
Recommended Water Storage	200 liter water bag
Required Water Filter	100 mesh screen filter (included in the kit)
Emitter Flow Rate	6 liter/hour (with 1 meter head)
Pressure Operating Range	0.75-3 meter head (0.075 to 0.3 bar)
System Uniformity	80-85%

Package and Weight

Package	Plastic bag in cardboard box
Package Size	25 x 38 x 51cm
Package Volume	0.011m ³
Gross Weight	2kg

Picture	Item	Quantity	Technical Specifications
BILL OF MATERIAL			
	200 Liter Water Bag	1	Inner liner wall thickness: 200 micron
	Tank Connector	1	25mm
	Elbow	2	PE, Female Threaded 25mm
	Hex Nipple	1	PE, Male Threaded 25mm
	Ball Valve (main)	1	PVC,Female Threaded, 25mm
	Filter	1	PE, 25mm Male Threaded
	Hose Connector	2	PE, 25mm, Male Threaded
	Hose Connector	1	PE, 25mm, Female Threaded
	Hose Clamp	3	25mm
	Lay-Flat Main Pipe	3 meters	LLDPE,25mm, 500 micron
	Lay-Flat Sub-Main Pipe	10 meters	500 micron, 25mm diameter
	Take-Off Valve	11	PE, 16mm
	Rubber Grommet	11	16mm
	Lay-Flat Laterals	11 x 10 meters	200 micron, 16mm diameter

	Microtube	360	1.2mm x 20cm
SPARES AND TOOLS			
	Joiners	3	16mm
	Take-Off Valve	3	16mm
	Rubber Grommet	3	16mm
	Lay-Flat Lateral Pipe	10 meters	200 micron, 16mm diameter
	Micro Tube	40	1.2mm x 20cm
	Lay-Flat Sleeve	15	200 micron, 16mm diameter, 1cm, for end of laterals
	Teflon tape	2	5 meter roll
	Lateral/Thumb Punch	3	To punch holes into the laterals

MAINTENANCE			
	Clean filter regularly.		Periodically flush sub main and laterals by opening end caps and running water through the system.
TROUBLE SHOOTING			
	If micro tube is clogged, remove microtube from lateral. Flick tube or blow through tube to remove debris. Re-insert into lateral.		If there is a leak or large cut in lateral, cut damaged section. Connect two pieces with a joiner.

INSTALLATION GUIDE - 100 SQM

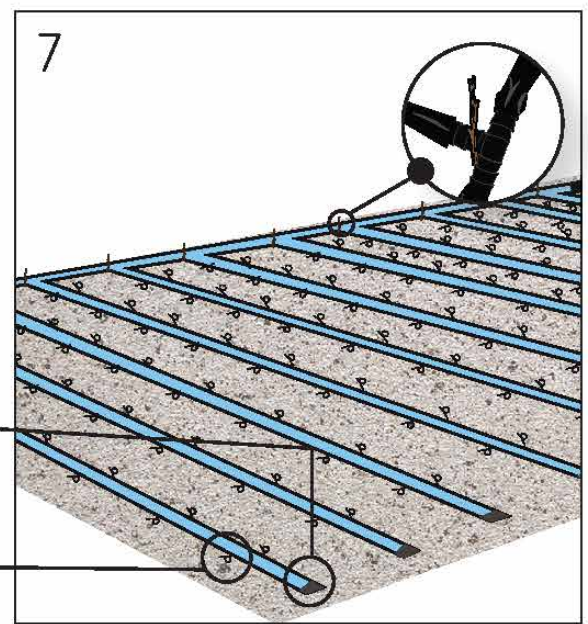
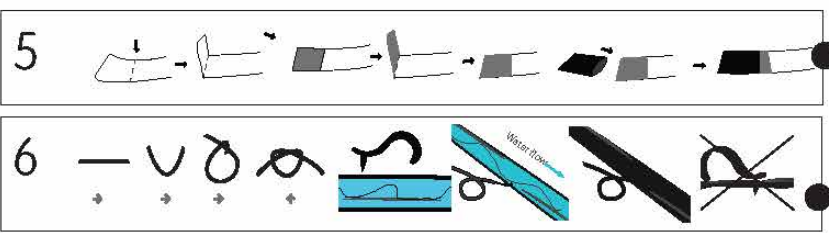
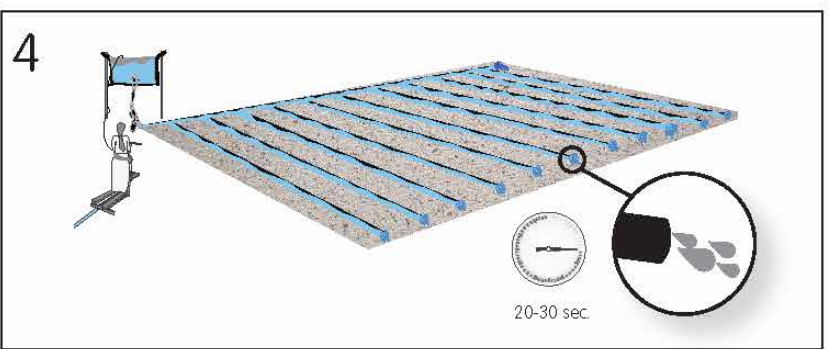
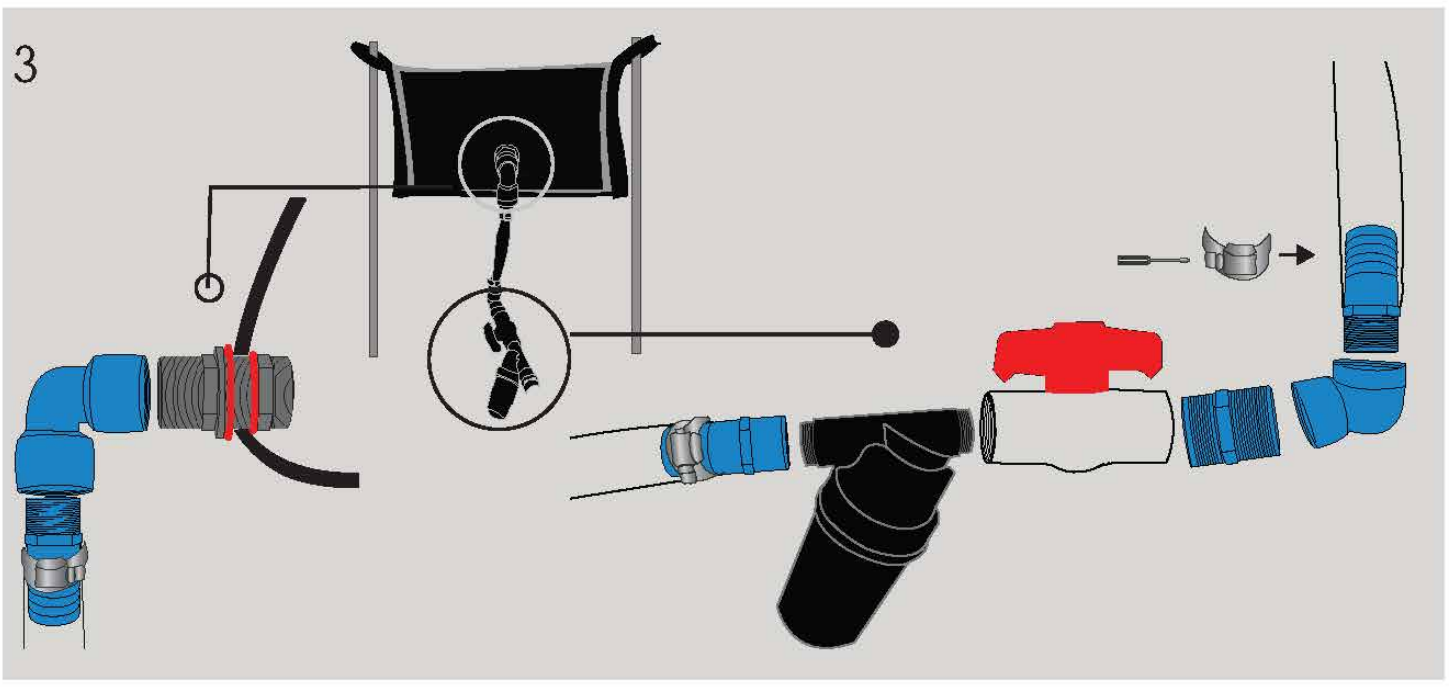
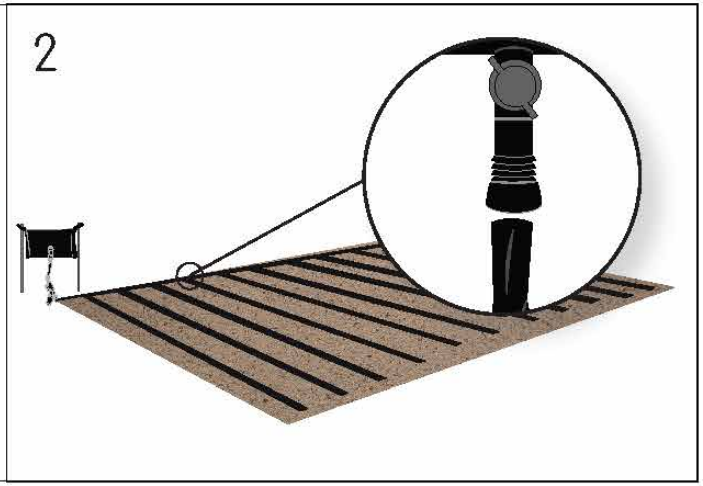
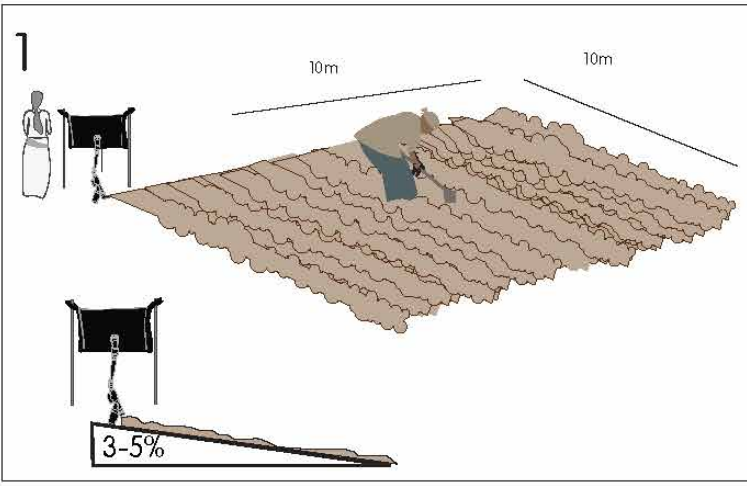



200 SQUARE METER MICRO-TUBE DRIP KIT

PRODUCED BY: HARVEL AZUD, INDIA

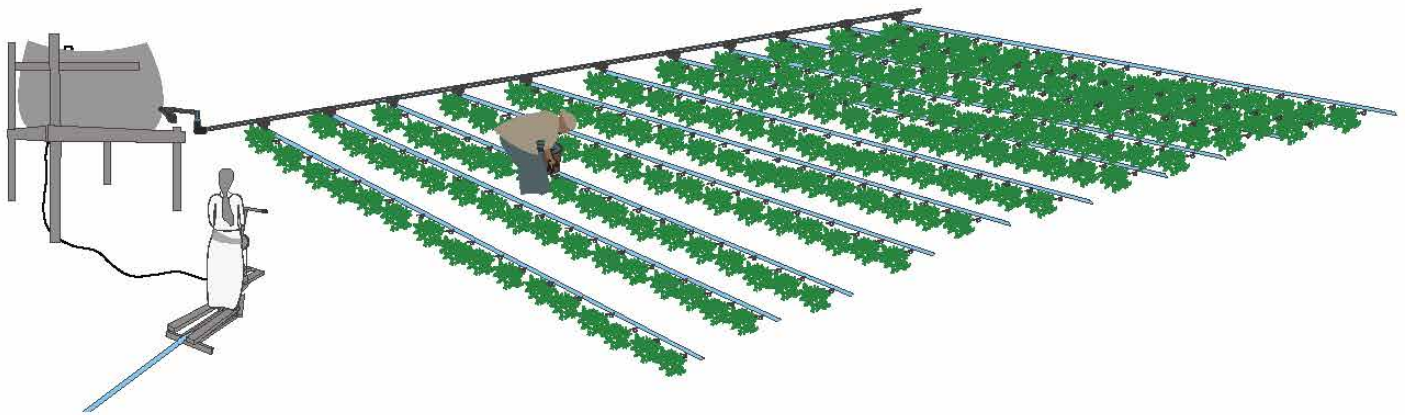

















Product Configuration





Plot Size	10 x 20 meter (pre-configured)
Row Spacing	1 meter
Microtube Emitter Spacing	30cm typical (determined by user)
Number of Laterals	11
Recommended Configuration	Sub-main located at top of field (pre-configured)
Recommended Water Storage	200 liter water bag (not included in the kit)
Required Water Filter	100 mesh screen filter (included in the kit)
Emitter Flow Rate	6 liter/hour (with 1 meter head)
Pressure Operating Range	0.75-3 meter head (0.075 to 0.3 bar)
System Uniformity	80-85%

Package and Weight

Package	Plastic Bag
Package Size	25 x 27.5 x 37.5 cm
Package Volume	0.025m ³
Gross Weight	5.5 kg

Picture	Item	Quantity	Technical Specifications
BILL OF MATERIAL			
	Tank Connector	1	25mm
	Elbow	2	PE, Female Threaded 25mm
	Hex Nipple	1	PE, Male Threaded 25mm
	Ball Valve (Main)	1	PVC, Female Threaded, 25mm
	Filter	1	PE, 25mm Male Threaded
	Hose Connector	2	PE, 25mm, Male Threaded
	Hose Connector	1	PE, 25mm, Female Threaded
	Hose Clamp	3	25mm
	Lay-Flat Main Pipe	3 meters	LLDPE, 25mm, 500 micron
	Lay-Flat Sub-Main Pipe	10.5 meters	500 micron, 25mm diameter
	Take-Off Valve	11	PE, 16mm
	Rubber Grommet	11	16mm
	Lay-Flat Laterals	11 x 20 meters	200 micron, 16mm diameter
	Microtube	730	1.2mm x 20cm

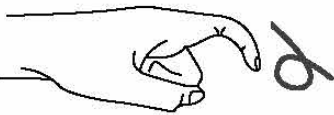
SPARES AND TOOLS			
	Joiners	3	16mm
	Take-Off Valve	3	16mm
	Rubber Grommet 16mm	3	16mm
	Lay-Flat Lateral Pipe	2 x 20 meters	200 micron, 16mm diameter
	Micro Tube	70	1.2mm x 20cm
	Lay-Flat Sleeve	13	200 micron, 16mm diameter, 1cm, for end of laterals
	Teflon tape	1	10 meter roll
	Lateral/Thumb Punch	5	To punch holes into the laterals

MAINTENANCE			
	Clean filter regularly.		Periodically flush sub main and laterals by opening end caps and running water through the system.
TROUBLE SHOOTING			
	If micro tube is clogged, remove microtube from lateral. Flick tube or blow through tube to remove debris. Re-insert into lateral.		If there is a leak or large cut in lateral, cut damaged section. Connect two pieces with a joiner.

INSTALLATION GUIDE - 200 SQM

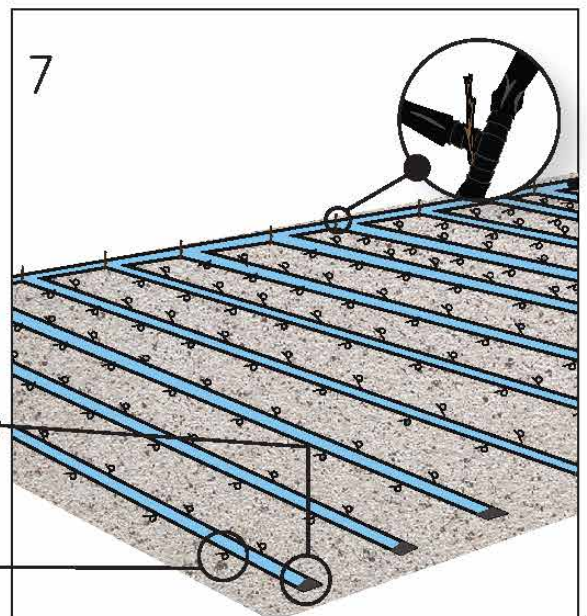
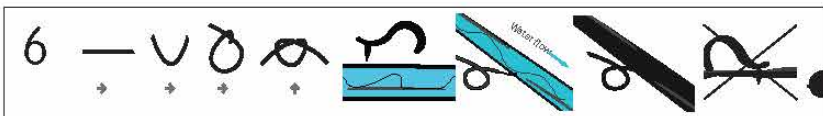
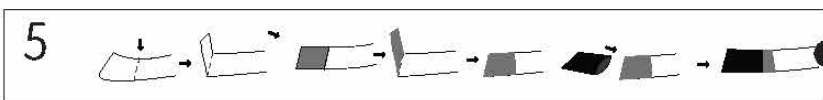
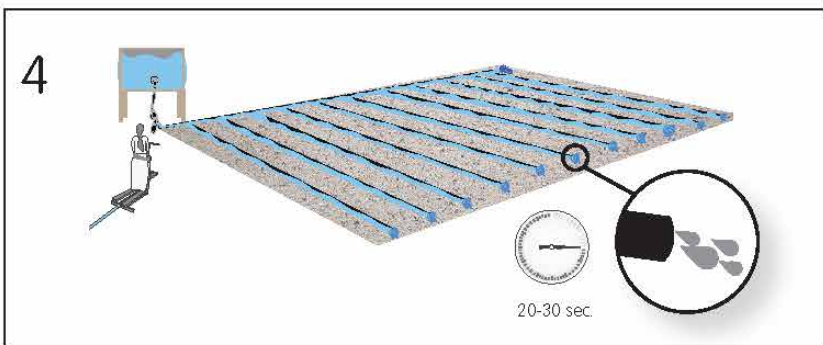
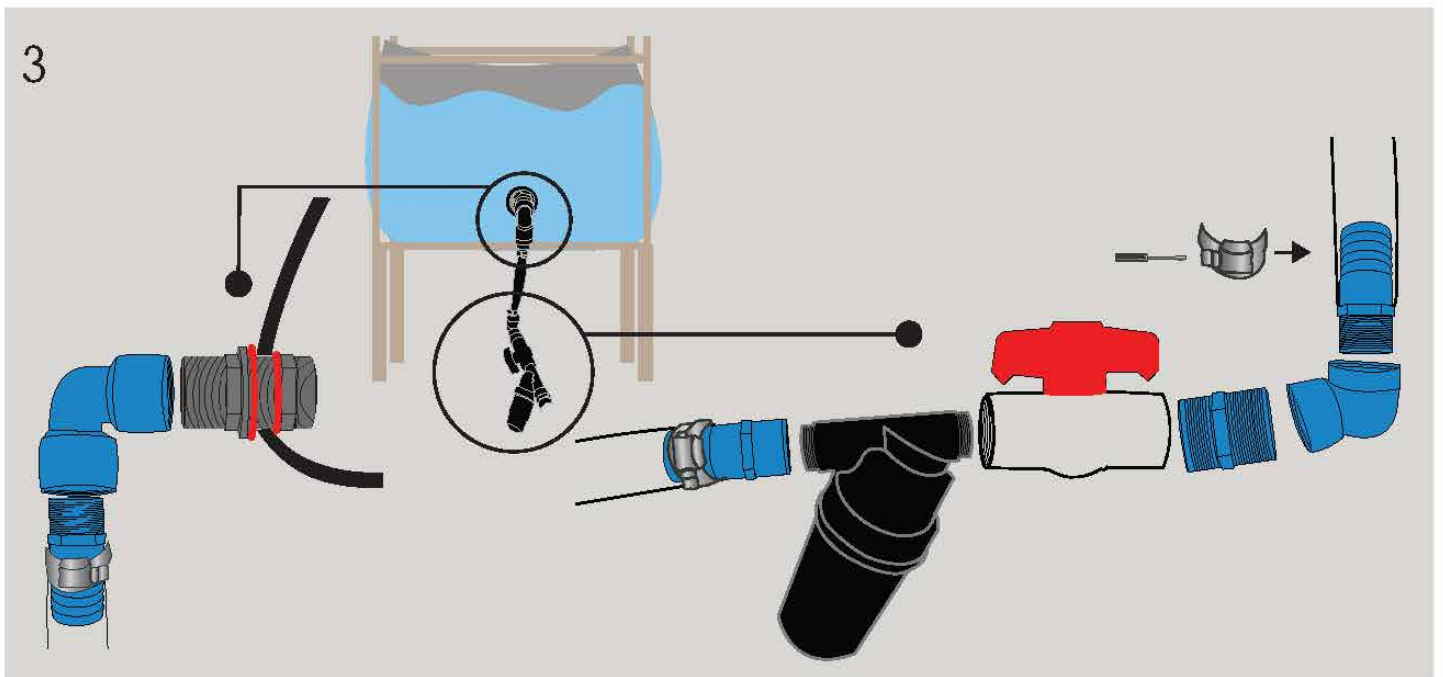
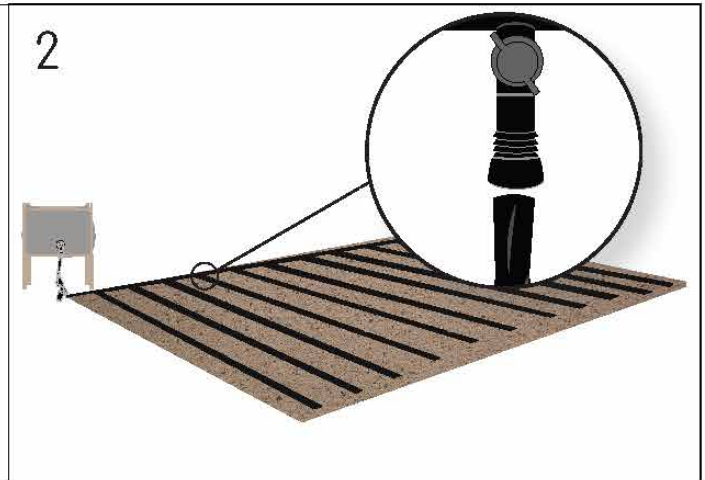
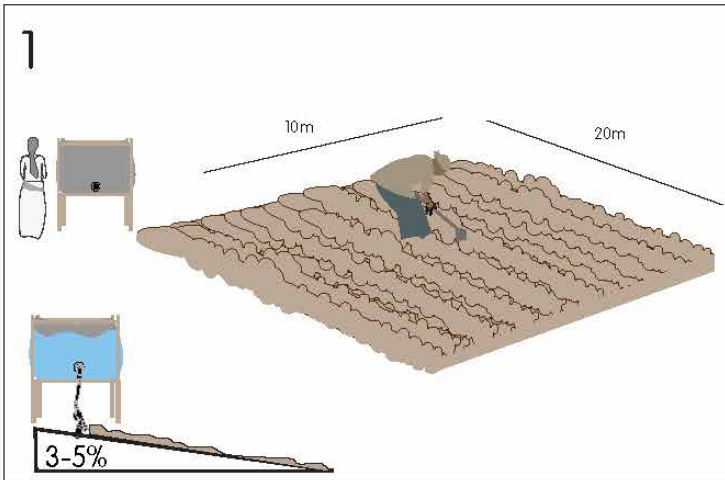



500 SQUARE METER MICRO-TUBE DRIP KIT

PRODUCED BY: HARVEL AZUD, INDIA

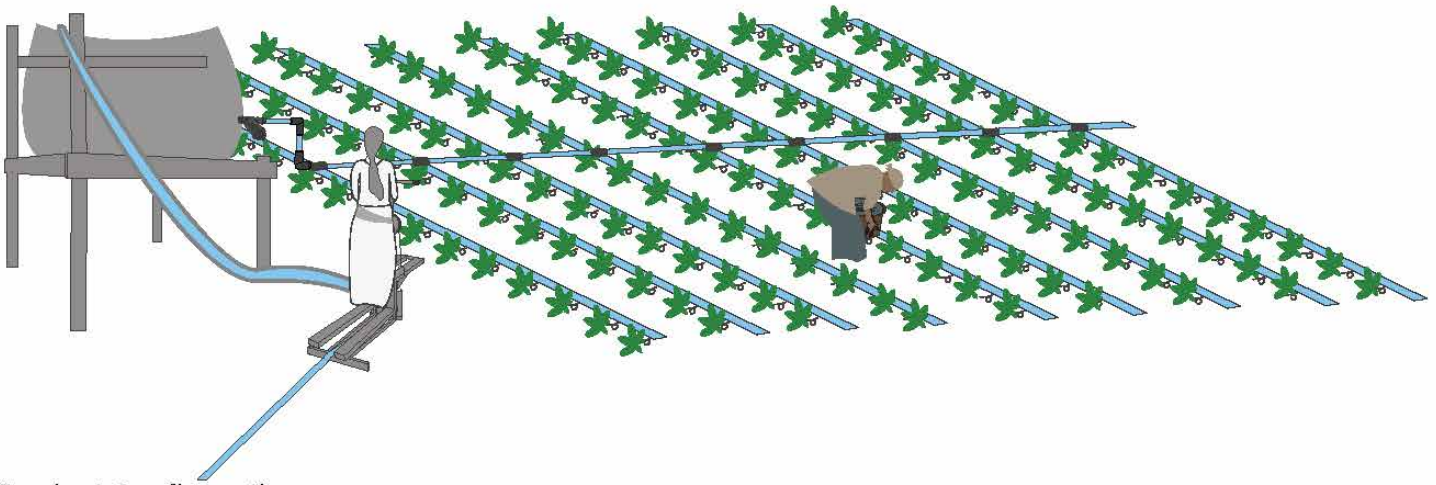









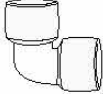



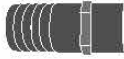





Product Configuration

Plot Size	20 x 25 meters (pre-configured)
Row Spacing	1 meter
Microtube Emitter Spacing	30cm typical (determined by user)
Number of Laterals	42
Recommended Configuration	Center main (pre-configured)
Recommended Water Storage	1000 liter water reservoir at least (not included in the kit)
Required Water Filter	100 mesh screen filter (included in the kit)
Emitter Flow Rate	6 liter/hour (with 1 meter head)
Pressure Operating Range	0.75-3 meter head (0.075 to 0.3 bar)
System Uniformity	80-85%

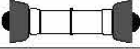
Package and Weight

Package	Carton Box
Package Size	25 x 38 x 51cm
Package Volume	0.046m ³
Gross Weight	11 kg





Picture	Item	Quantity	Technical Specifications
BILL OF MATERIAL			
	Tank Connector	1	PE, 40mm
	Elbow	2	PE, Female Threaded 40mm
	Hex Nipple	1	PE, Male Threaded 40mm
	Ball Valve (Main)	1	PVC, Female Threaded, 40mm
	Filter	1	PE, 38mm (ID) Male Threaded
	Hose Connector	3	PE, 40mm, Male Threaded
	Hose Connector	1	PE, 40mm, Female Threaded
	Hose Clamp	4	40mm
	Lay-Flat Main Pipe	3 meters	LLDPE, 40mm, 500 micron
	Lay-Flat Sub-Main Pipe	20.5 meters	500 micron, 40mm diameter
	Take-Off Valve	42	PE, 16mm
	Rubber Grommet	42	16mm
	Lay-Flat Laterals	42 x 12.5 meters	200 micron, 16mm diameter
	Microtube	1,750	1.2mm x 20cm

SPARES AND TOOLS			
	Joiners	5	16mm
	Take-Off Valve	3	16mm
	Rubber Grommet 16mm	3	16mm
	Lay-Flat Lateral Pipe	4 x 12.5 meters	200 micron, 16mm diameter
	Micro Tube	200	1.2mm x 20cm
	Lay-Flat Sleeve	50	200 micron, 16mm diameter, 1cm, for end of laterals
	Teflon tape	1	10 meter roll
	Lateral/ Thumb Punch	7	To punch holes into the laterals

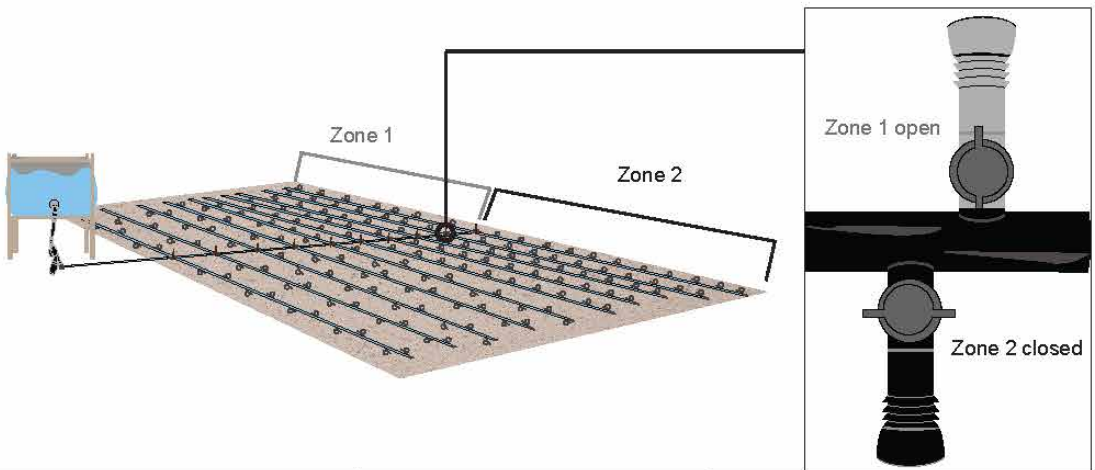
OPERATIONS

For optimal results only run one zone at a time.

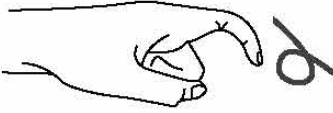

MAINTENANCE			
	Clean filter regularly.		Periodically flush sub main and laterals by opening end caps and running water through the system.
TROUBLE SHOOTING			
	If micro tube is clogged, remove microtube from lateral. Flick tube or blow through tube to remove debris. Re-insert into lateral.		If there is a leak or large cut in lateral, cut damaged section. Connect two pieces with a joiner.

INSTALLATION GUIDE - 500 SQM

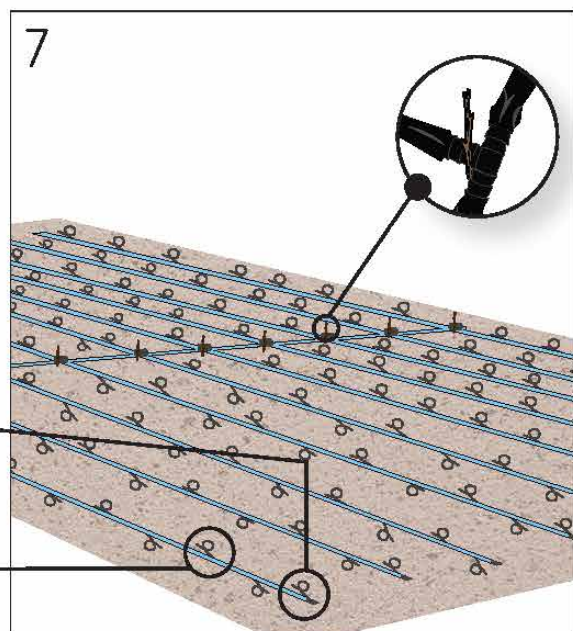
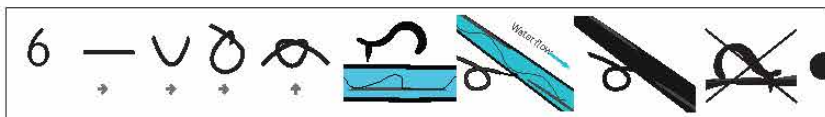
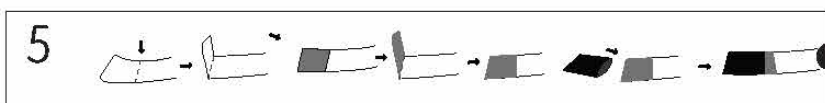
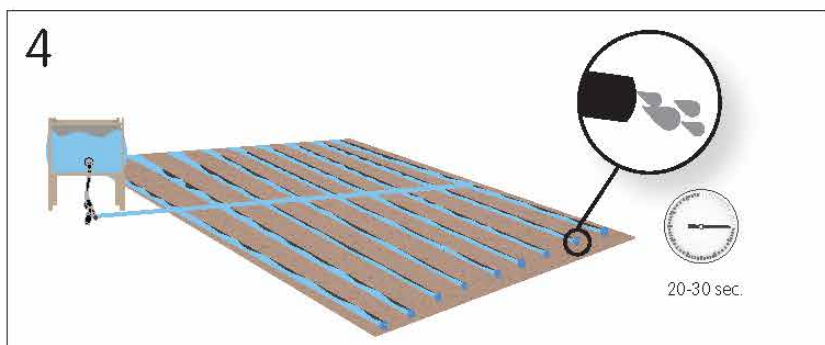
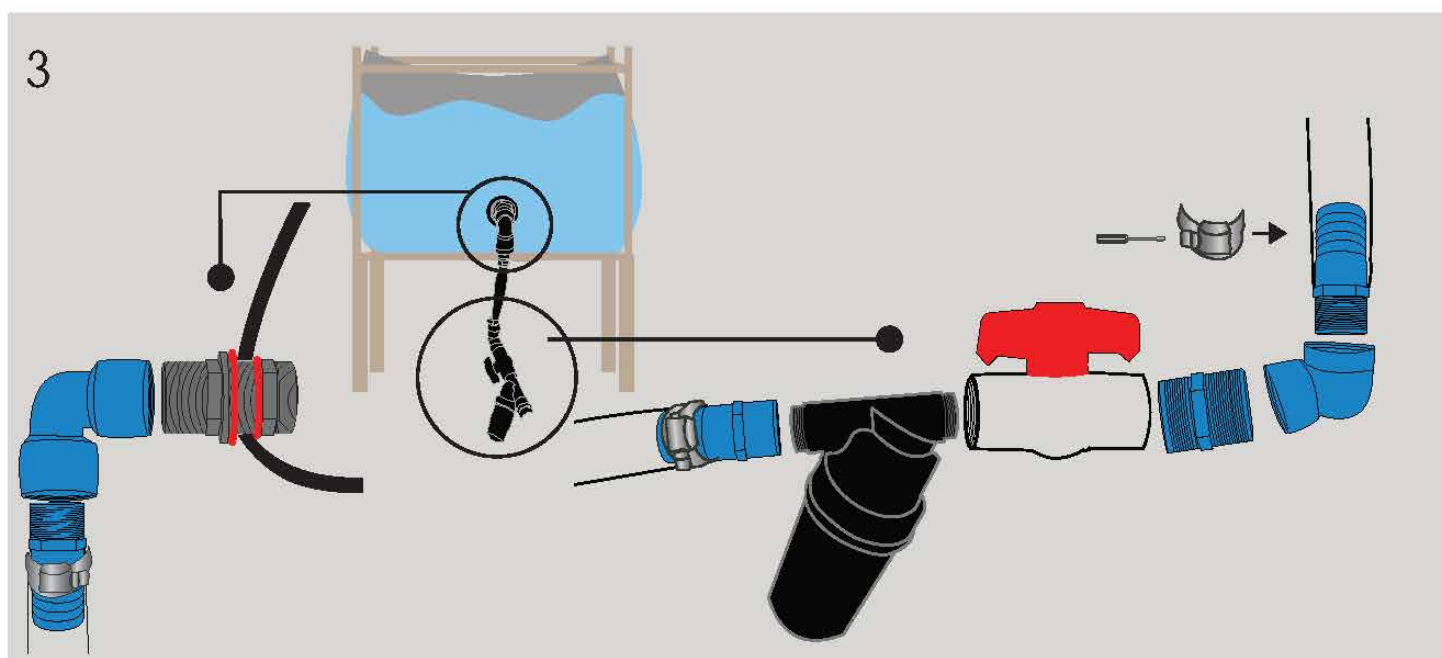
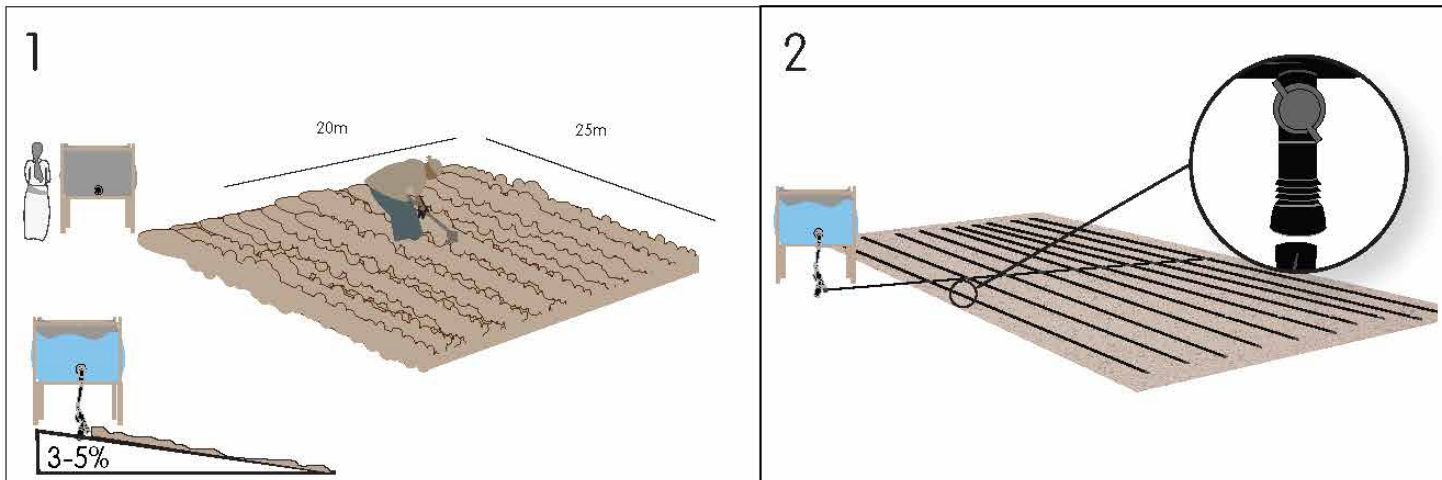



200 SQUARE METER INLINE DRIP KIT

PRODUCED BY: HARVEL AZUD, INDIA

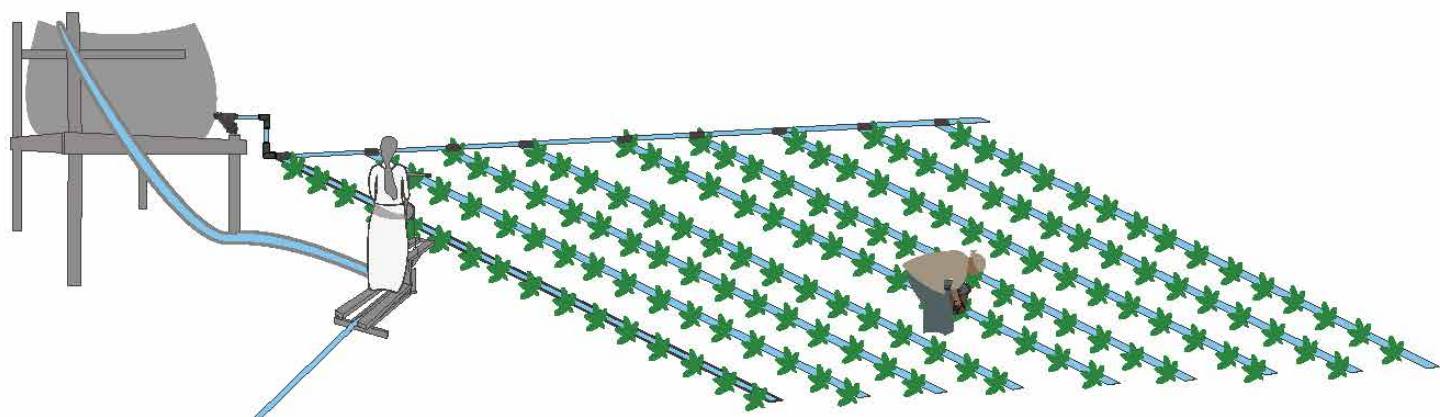









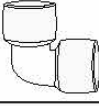

Product Configuration

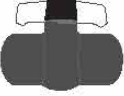
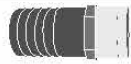
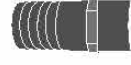

Plot Size	10 x 20 meter (pre-configured)
Row Spacing	1 meter
Number of Laterals	11
Recommended Configuration	Sub-main located at top of field (pre-configured)
Recommended Water Storage	1000 liter water bag (not included in the kit)
Required Water Filter	150 mesh screen filter (included in the kit)
Emitter Flow Rate	1 liter/hour (with 1 meter pressure)
Pressure Operating Range	1-10 meter head
System Uniformity	90-95%

Package and Weight

Package	Plastic bag inside box
Package Size	25 x 38 x 51cm
Package Volume	0.025m ³
Gross Weight	5.0 kg

Picture	Item	Quantity	Technical Specifications
BILL OF MATERIAL			
	Tank Connector	1	PE, 25mm, Male Threaded
	Filter	1	PE, 25mm, 150 micron, non-corrosive, Male x Male
	Lay-Flat Main Pipe	3 meters	LLDPE, 25mm, 500micron
	Elbow	3	PE, 25mm, Female Threaded x Male Threaded
	Coupler	1	PE, 25mm, Male Threaded x Male Threaded
	Ball Valve (Main)	1	PVC, 25mm, Female Threaded x Female Threaded
	Hose Connector	4	PE, 25mm, Male Threaded x Hose
	Hose Connector	1	PE, 25mm, Female Threaded x Hose
	Hose Clamp	5	25mm
	Lay-Flat Sub-Main Pipe	11 meters	LLDPE, 25mm, 500 micron
	Take-Off Valve	11	PE, 16mm
	Rubber Grommet	11	PE, 16mm
	Azud Line	11 x 20 meters	16mm-40cm-3.8LPH,200 micron

SPARES AND TOOLS			
	Joiners	3	PE, 16mm
	Take-Off Valve	3	PE, 16mm
	Rubber Grommet	3	16mm
	Azud line	20 meters	16mm-40cm-3.8LPH, 200 micron
	Teflon tape	1	10 meter roll

MAINTENANCE			
	Clean filter regularly.		Periodically flush sub main and laterals by opening end caps and running water through the system.
TROUBLE SHOOTING			
			If there is a leak or large cut in lateral, cut damaged section. Connect two pieces with a joiner.

INSTALLATION GUIDE - 200 SQM

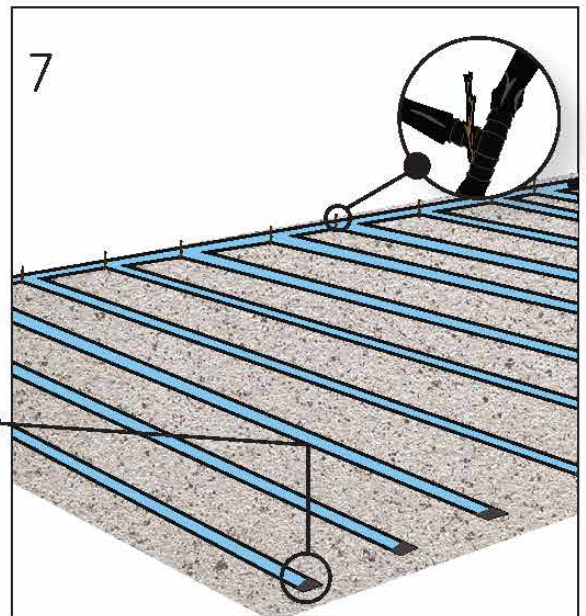
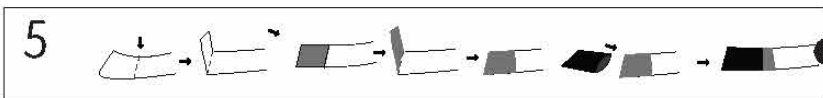
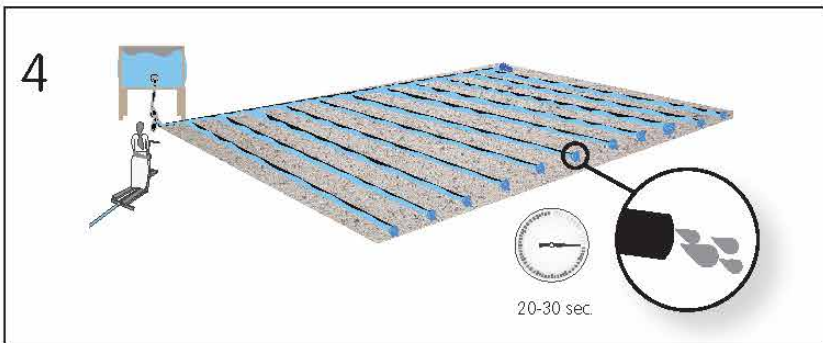
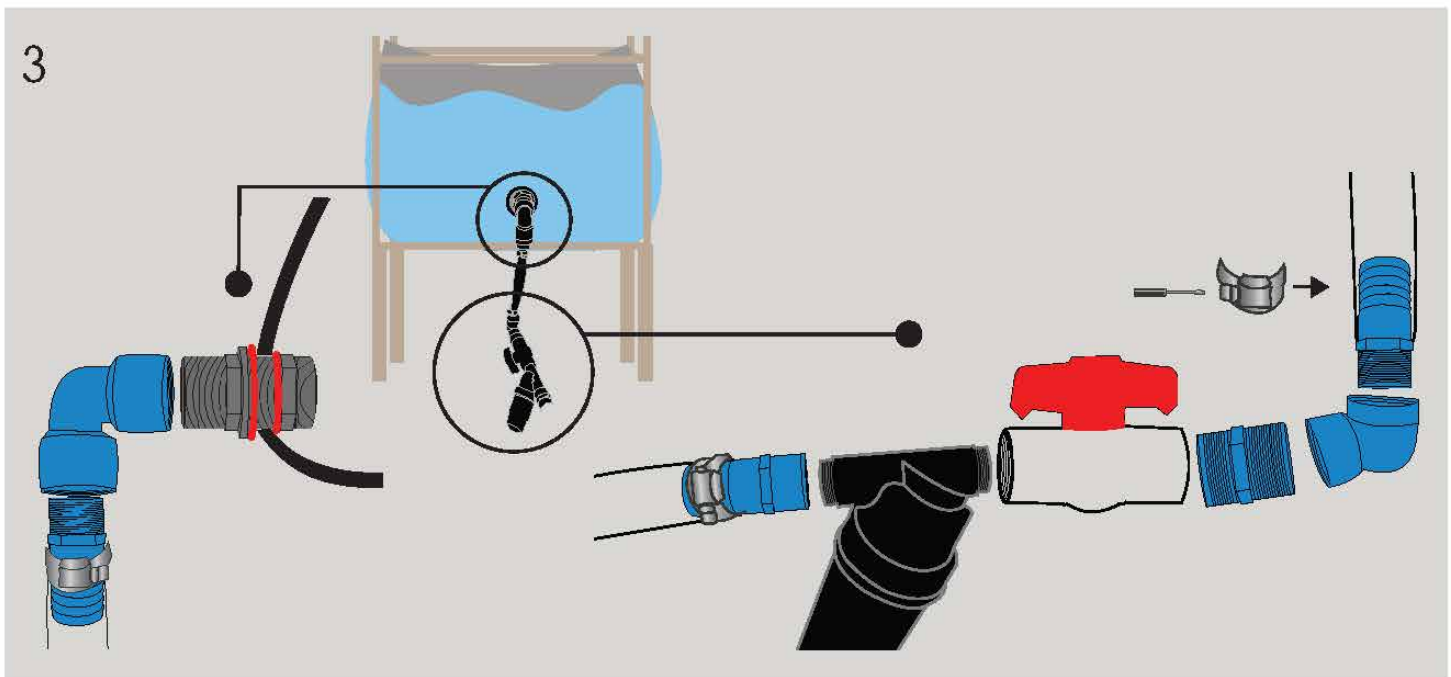
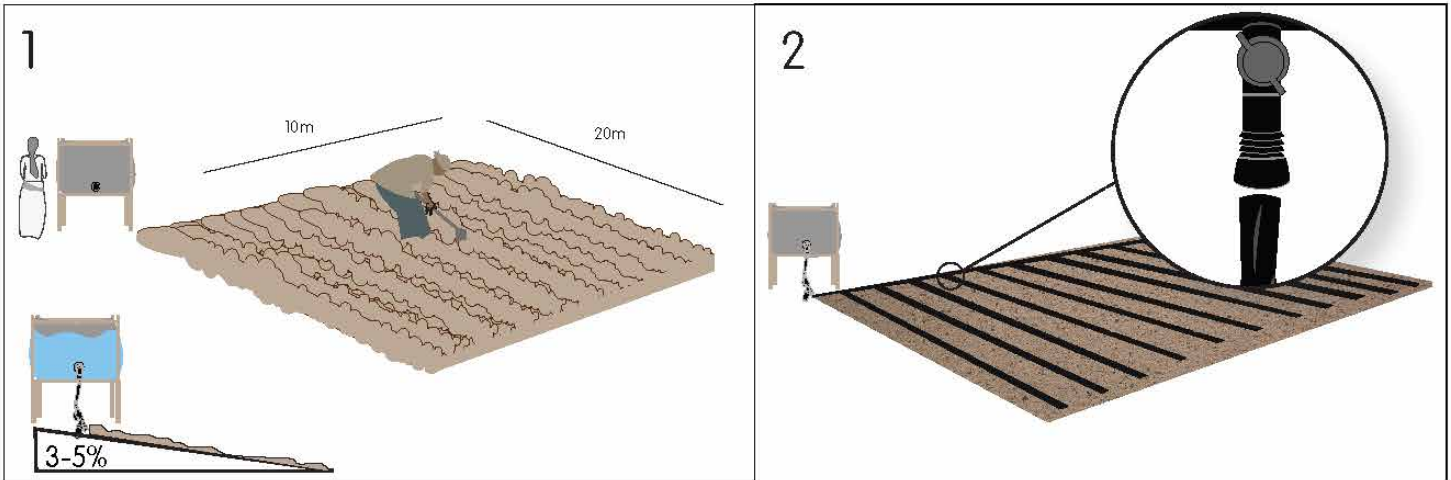



500 SQUARE METER INLINE DRIP KIT

PRODUCED BY: HARVEL AZUD, INDIA

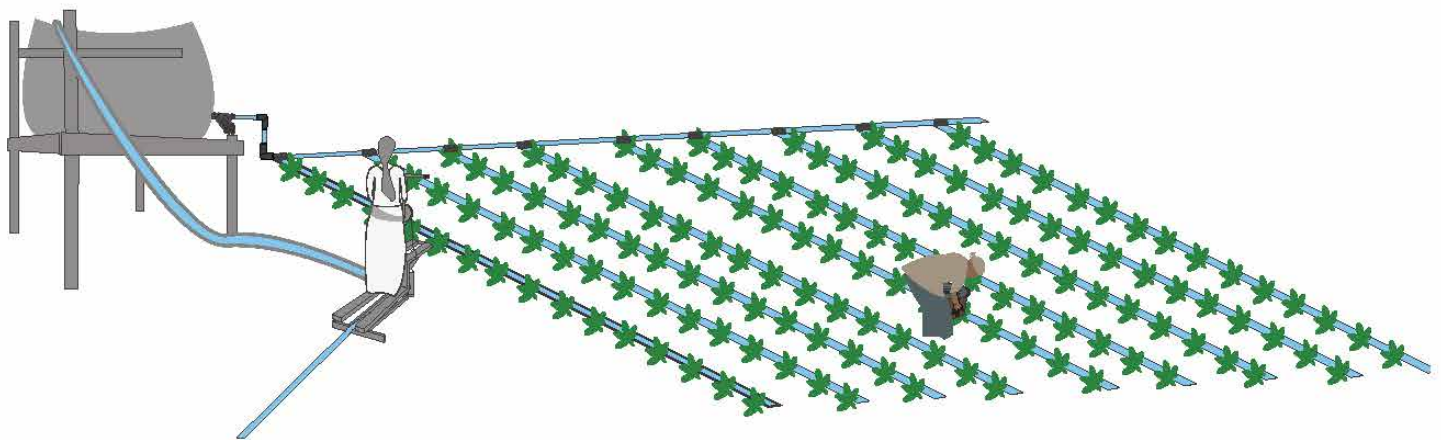













Product Configuration

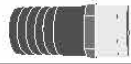
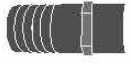

Plot Size	25 x 20 meter (pre-configured)
Row Spacing	1 meter
Number of Laterals	21
Recommended Configuration	Sub-main located at top of field (pre-configured)
Recommended Water Storage	1000 or more liter water bag (not included in the kit)
Required Water Filter	150 mesh screen filter (included in the kit)
Emitter Flow Rate	1 liter/hour (with 1 meter head)
Pressure Operating Range	1-10 meter head
System Uniformity	90-95%

Package and Weight

Package	Cardboard Box
Package Size	25 x 38 x 51cm
Package Volume	.050m ³
Gross Weight	11.50kg

Picture	Item	Quantity	Technical Specifications
BILL OF MATERIAL			
	Tank Connector	1	PE, 40mm, Male Threaded
	Filter	1	PE, 40mm /38 mm ID Screen Filter of Azud Brand
	Lay-Flat Main Pipe	3 meters	LLDPE, 40mm, 500micron
	Elbow	3	PE, 40mm, Female Threaded x Male Threaded
	Coupler	1	PE, 40mm, Male Threaded x Male Threaded
	Ball Valve (Main)	1	PVC, 40mm, Female Threaded
	Hose Connector	4	PE, 40mm, Male Threaded x Hose
	Hose Connector	1	PE, 40mm, Female Threaded x Hose
	Hose Clamp	5	40mm
	Lay-Flat Sub-Main Pipe	21 meters	LLDPE, 40mm, 500 micron
	Take-Off Valve	21	PE, 16mm
	Rubber Grommet	21	16mm
	Azud line,	21x 26 meters	16mm-40cm-3.8LPH,200 micron

SPARES AND TOOLS			
	Joiners	10	PE, 16mm
	Shut-Off Valve	5	PE, 16mm
	Rubber Grommet 16mm	5	15mm
	Azud line	25 meters	16mm-40cm-3.8LPH, 200 micron
	Teflon tape	1	10 meter roll

MAINTENANCE			
	Clean filter regularly.		Periodically flush sub main and laterals by opening end caps and running water through the system.
TROUBLE SHOOTING			
			If there is a leak or large cut in lateral, cut damaged section. Connect two pieces with a joiner.

INSTALLATION GUIDE - 500 SQM

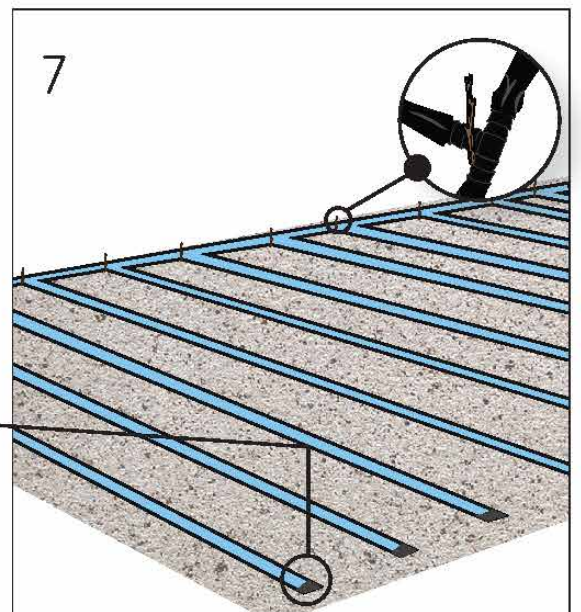
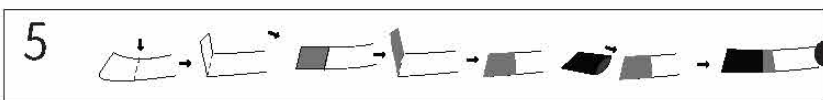
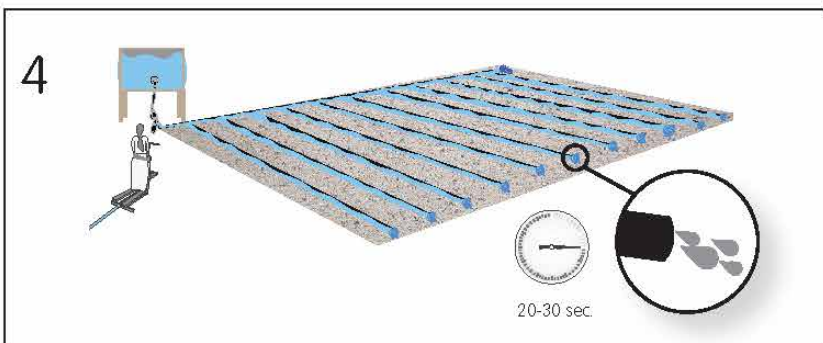
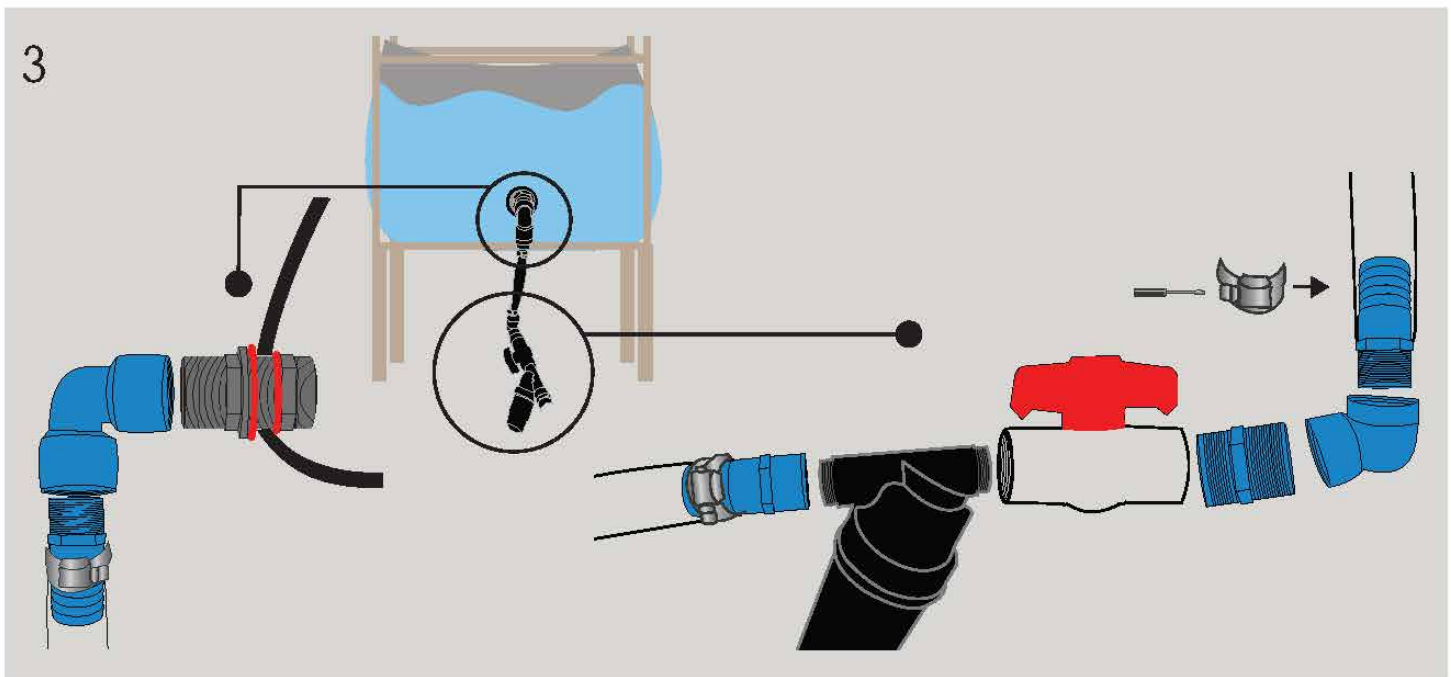
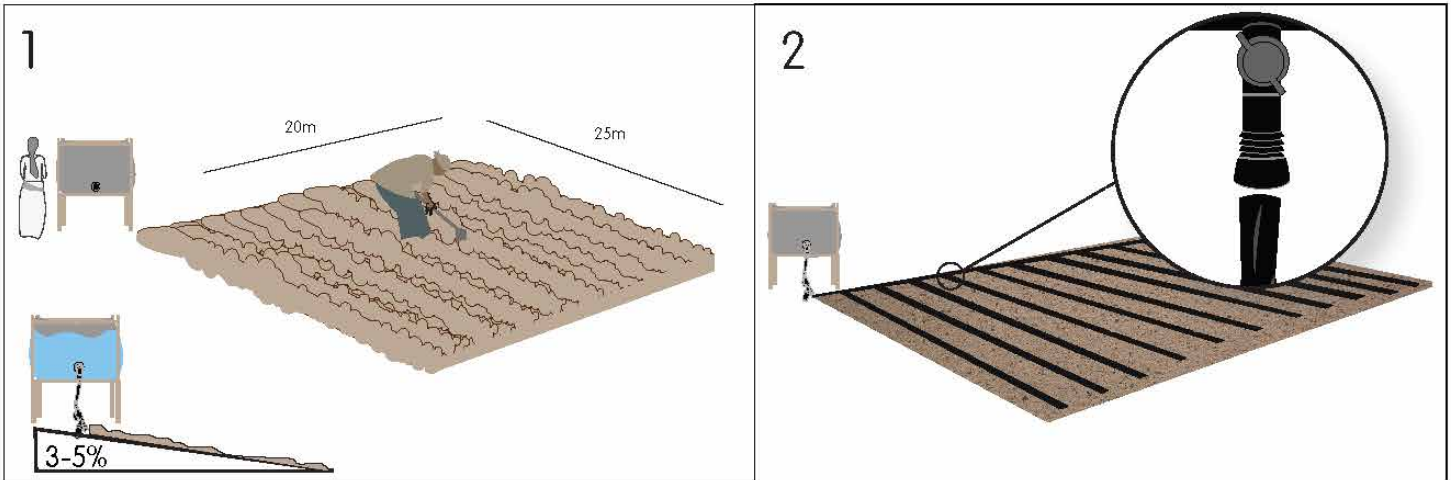



500 SQUARE METER INLINE DRIP KIT

PRODUCED BY: TORO MICRO-IRRIGATION, USA
MINIMUM ORDER REQUIREMENT: 36 KITS

iDE and Toro have collaborated to address the irrigation needs of smallholder farmers throughout the developing world. The result is a 500 sqm drip kit built around Toro's proprietary Aqua-Traxx Turbulent Flow Drip Tape Technology. Aqua-Traxx provides precise and uniform water distribution and a high resistance to clogging, which allows farmers to maximize their crop potential.

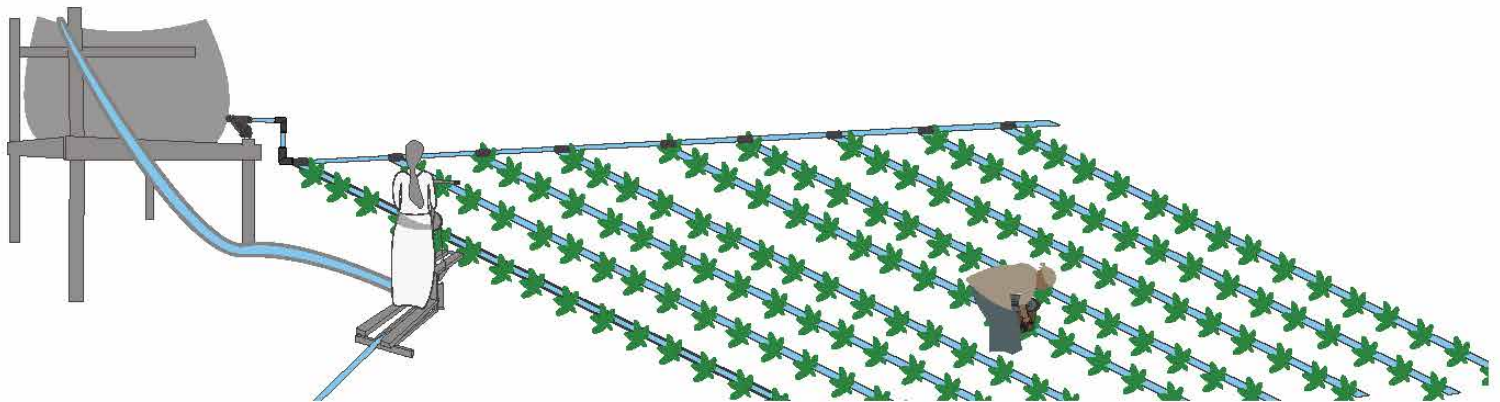

Product Configuration

Plot Size	25 x 20 meter (pre-configured)
Row Spacing	1 meter
Emitter Spacing	12 inches
Water required per hour	2 meters of head, 1,963 LPH/500 SQM
Number of Laterals	25
Recommended Configuration	Sub-main located at top of field (pre-configured)
Recommended Water Storage	1000 liter, or more, water bag (not included in the kit)
Required Water Filter	150 mesh screen filter (included in the kit)
Emitter Flow Rate	2.8 liter/hour (with 5-10 meter head)
Pressure Operating Range	1.5-10 meter head (.4 to 1bar)
System Uniformity	Greater then 90%



Package and Weight

Package	Cardboard Box
Package Size	35.6 x 35.6 x 48cm
Package Volume	.060m3
Gross Weight	16.8 kg



Picture	Item	Quantity	Technical Specifications
BILL OF MATERIAL			
	Tank Connector	1	PVC 1-1/2" Male Threaded
	Filter	1	Toro Plastic Screen Filter 1-1/2" Male x Male Threaded
	Elbow	2	PVC 1-1/2" Female x Female Threaded
	Coupler	1	PVC 1-1/2" PVC Male x Male Threaded
	Coupler	1	Coupling PVC 1-1/2" Female x Female Threaded
	Ball Valve (Main)	1	PVC 1-1/2" PVC Female x Female Threaded
	Male Adapter	4	PVC 1-1/2" Male Threaded x Insert
	Hose Clamp	6	Stainless steel worm Gear 2"
	Blue Stripe Oval Hose	27 meters	Toro 1-1/2", 27 meters
	Barb Shutoff Valve	28	Toro Pro-Loc 5/8" x 400
	Drip Tape	550 meters	Toro Aqua-Traxx 5/8", 550 meters

SPARES			
	Pro-Loc	10	Toro 5/8" Tape x Tape Coupler
	Barb Shutoff Valve	2	5/8" Toro Pro Loc 5/8" barbed Valves
	Hose Clamp	2	Stainless steel worm Gear 2
TOOLS REQUIRED FOR ASSEMBLY			
Flat blade screwdriver			
Oval hose punch (INS 4005)			
Teflon tape			
Knife			

MAINTENANCE			
	Clean filter regularly.		Periodically flush sub main and laterals by opening end caps and running water through the system.
TROUBLE SHOOTING			
		If there is a leak or large cut in lateral, cut damaged section. Connect two pieces with a joiner.	



1,000 SQUARE METER INLINE DRIP KIT

PRODUCED BY: HARVEL AZUD, INDIA

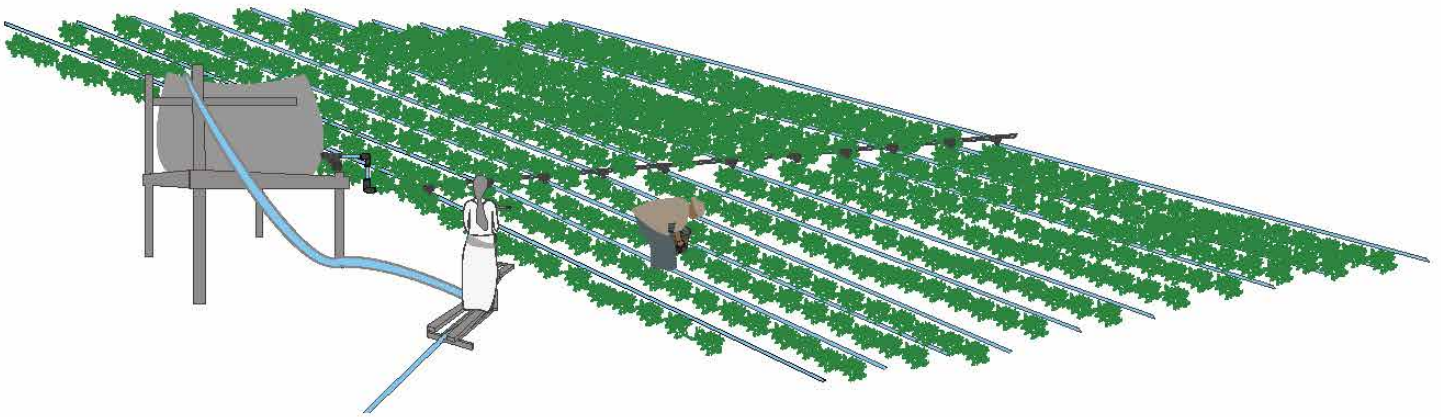













Product Configuration



Plot Size	30 x 33 meter (pre-configured)
Row Spacing	1 meter
Number of Laterals	62
Recommended Configuration	Sub-main located at center of field (pre-configured)
Recommended Water Storage	1000 liter, or more, water bag (not included in the kit)
Required Water Filter	150 mesh screen filter (included in the kit)
Emitter Flow Rate	1 liter/hour (with 1 meter pressure)
Pressure Operating Range	1-10 meter head (0.075 to 0.3 bar)
System Uniformity	90-95%

Package and Weight

Package	Cardboard Box
Package Size	25 x 38 x 51cm
Package Volume	.10m ³
Gross Weight	21.00kg

Picture	Item	Quantity	Technical Specifications
BILL OF MATERIAL			
	Tank Connector	1	PE, 50.8mm, Male Threaded
	Filter	1	PE, 50.8mm ID Screen Filter of Azud Brand, Male threaded x Male Threaded
	Lay-Flat Main Pipe	3 meters	LLDPE, 50.8mm, 900micron
	Elbow	3	PVC, 50.8mm, Female Threaded x Male Threaded
	Coupler	1	PVC ,50.8mm, Male Threaded x Male Threaded
	Ball Valve (Main)	1	PVC, 50.8mm, Female Threaded x Female Threade
	Hose Connector	4	PE 50.8mm Male Threaded x hose
	Hose Connector	1	PE, 50.8 mm Female Threaded x hose
	Hose Clamp	5	50.8mm
	Lay-Flat Sub-Main Pipe,	30.5 meters	LLDPE, 50.8mm, 900 micron
	Take-Off Valve	62	PE, 16mm
	Rubber Grommet	62	PE, 16mm
	Azud line	2 rolls	16mm-40cm-3.8LPH,200micron (1 roll of 1000 mtr + 1 roll of 54 mtrs)

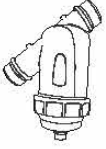
SPARES AND TOOLS			
	Joiners	10	PE, 16mm
	Hose Clamp	2	63mm
	Take-Off Valve	5	PE, 16mm
	Rubber Grommet 16mm	5	PE, 16mm
	Azud line	2 x 17 meters	16mm-40cm-3.8LPH, 200 micron
	Teflon tape	1	10 meter roll

MAINTENANCE			
	Clean filter regularly.		Periodically flush sub main and laterals by opening end caps and running water through the system.
TROUBLE SHOOTING			
			If there is a leak or large cut in lateral, cut damaged section. Connect two pieces with a joiner.



MINI SPRINKLER KITS

PRODUCED BY: BHINGE BROTHERS, INDIA

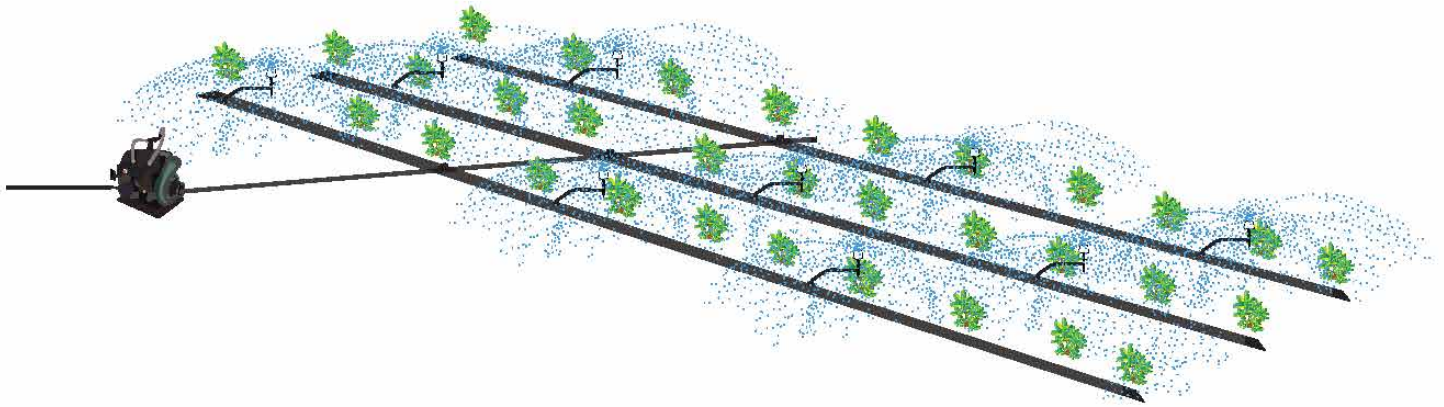

Overview

Sprinkler irrigation systems can bring water to the roots of crops in sloped fields and are an ideal option for closely-spaced crops in water-scarce areas where surface flooding is not an option. Additionally, mini sprinklers' relatively low flow allows them to be used in erosion-prone areas, where higher flow sprinklers (i.e. impact sprinklers) would not work. The sprinklers can be moved to different locations to irrigate larger fields, or alternatively, higher pressure can cast a wider irrigation circle.











Ideally, mini sprinklers are to be used with a pressure treadle pump or any other pump that provides 5-8 meters pressure head. The 500 and 1,000 square meter sprinkler kits come with a 50 mm hose connectors to attach the systems to a pump and a screen/mesh fabric to avoid clogging. All necessary stakes and feeder lines are included

The 500 and 1,000 square meter sprinkler kits require more pressure than drip systems do (5-8 meters pressure head compared to 0.75-3 meters). Because the irrigation circles wet a larger portion of the field than drip emitters do, higher weed growth, increase of fungal growth incidences, and more difficult crop access should be anticipated with sprinkler use.

Mini sprinklers can irrigate crops of medium height (approximately 0.5 meters). Mini sprinklers are not designed to be used with widely spaced plans, such as orchards, or with tall crops, such as sugarcane or bamboo. The application uniformity is influenced by wind direction and pressure head.



500 SQUARE METER MINI SPRINKLER









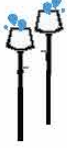

Picture	Item	Quantity	Technical Specifications
BILL OF MATERIAL			
	Mini Sprinklers	9	Plastic Spinner Head, 45cm Stake
	Laterals	3 x 1 meters	PE, Rigid, 16mm
	Laterals	6 x 3.5 meters	PE, Rigid, 16mm
	Laterals	3 x 7 meters	PE, Rigid, 16mm
	Take-Off Tee	3	PE, 16mm
	Take-Off Valves	6	PE, 16mm
	Grommets	6	Virgin Rubber
	Lay-Flat Pipe	25 meters	LLDPE 50mm diameter
	Main	3 meters	LLDPE, 63mm, 900 micron
	Hose Clamp	3	Metal, 50mm
	Hose connector	3	

PRODUCT SPECIFICATIONS

Field Size	Operation Pressure Range	Sprinkler Spacing	Water Application Rate per area
500 sqm	5-8 meters	7 x 7 meters	4 (l/m ² /hr)



1,000 SQUARE METER MINI SPRINKLER

Picture	Item	Quantity	Technical Specifications
BILL OF MATERIAL			
	Mini Sprinklers	16	Plastic Spinner Head, 45cm Stake
	Laterals	8 x 1 meters	PE, Rigid, 16mm
	Laterals	8 x 3.5 meters	PE, Rigid, 16mm
	Laterals	8 x 7 meters	PE, Rigid, 16mm
	Take-Off Tee	8	PE, 16mm
	Take-Off Valves	8	PE, 16mm
	Grommets	8	Virgin Rubber
	Lay-Flat Pipe	25 meters	LLDPE 50mm diameter
	Main	3 meters	LLDPE, 63mm, 900 micron
	Hose Clamp	3	Metal, 50mm
	Hose connector	1	
	Screen/ Mesh Fabric	1	

PRODUCT SPECIFICATIONS

Field Size	Operation Pressure Range	Sprinkler Spacing	Water Application Rate per area
1,000 sqm	5-8 meters		4 (l/m ² /hr)



EcoFlo MOBILE PRESSURE TREADLE PUMP

PRODUCED BY: BHINGE BROTHERS, INDIA





Overview

The EcoFlo pressure treadle pump is a human-powered pump designed to lift water from a maximum depth of 8 meters and push water 15 meters. By stepping up and down on treadles, which drive pistons, groundwater is drawn to the surface.

The EcoFlo pump frame and treadles are constructed of steel, while the cylinders and pistons are made from plastic, resulting in a lighter weight and cheaper mobile pressure treadle pump option.

The EcoFlo pressure treadle pump is mobile, allowing for easy use in large fields with multiple water sources and for relocation to secure locations when the pump is not being used. The pump can easily be coupled with a low pressure drip or sprinkler system.

The pump comes with a foot valve (allowing for easier priming), suction hose, layflat for the discharge hose, and a piston wrench.

Picture	Item	Quantity	Technical Specifications
BILL OF MATERIAL			
	Pressure Treadle Pump	1	
	Rigid Suction Hose	1 x 7 meters	40mm
	Lay-Flat Outlet Hose	7 meters (Can be increased on customer request)	LLDPE, 50mm diameter
	Check Foot Valve with Debris Screen	1	PE, 40mm diameter
	Hose Clamp	2	
SPARES AND TOOLS			
	Piston Wrench	1	
	Outlet Options	1 each	
	Bolts	2	

PRODUCT SPECIFICATIONS	
Overall Dimensions	With handle: 1.1 x 0.8 x 0.3 meter Pump head & frame only: 0.5 x 0.8 x 0.3 meter
Maximum Suction Depth	8 meters
Maximum Pumping Height	15 meters

ECOFLO MOBILE PRESSURE TREADLE PUMP OUTPUTS	
Total Suction and Lift	Water Output (liters/min)
1 meter	80
5 meters	60
9 meters	30

* Assumes 80% irrigation efficiency and total pumping head of 3 meters
* Assumes 2 hour sustainable exertion rate for an average pump user



SAAJHI PRESSURE TREADLE PUMP

PRODUCED BY: XYLEM INC., HQ IN THE USA;
MANUFACTURED IN INDIA. MINIMUM ORDER REQUIREMENT : 80



Overview

Developed by Xylem Inc., the Saajhi treadle pump allows a farmer to pump pressurized water from a maximum depth of 8 meters. Unlike traditional treadle pumps with pistons, the Saajhi uses diaphragm pumps to draw water to the surface.

The Saajhi pump is mobile, allowing for easy use in large fields with multiple water sources and for

relocation to secure locations when the pump is not being used. The pump can easily be coupled with a low pressure drip or sprinkler system.

All accessories for the pump (suction hose and outlet hose) must be purchased separately.

PRODUCT SPECIFICATIONS

Overall Dimensions	19.5 x 18.5 x 42 inches, 49.5 x 47 x 106.7 centimeters, handle removed
Maximum Suction Depth	4.57 meters
Maximum Pumping Height	3.5 meters

* Assumes 80% irrigation efficiency and total pumping head of 3 meters
* Assumes 2 hour sustainable exertion rate for an average pump user



SKI MOBILE PRESSURE TREADLE PUMP

PRODUCED BY: SHREE INDUSTRIES, INDIA

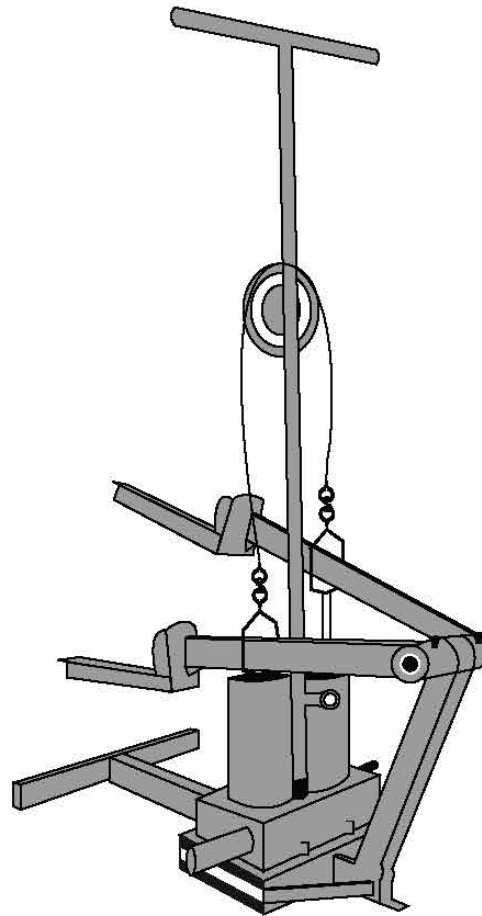

Overview

The Shree Industries (SKI) pressure treadle pump is a human-powered pump designed to lift water from a maximum depth of 6-8 meters and push water more than 10 meters. By stepping up and down on treadles, which drive pistons, groundwater is drawn to the surface.

The SKI pump cylinders, treadles, and frame are constructed of galvanized steel, resulting in a sturdy, rust-resistant pump. Piston rings and valve components are made from high quality rubber. Each treadle has a grease fitting at the pivot point to ensure easy motion and minimize wear.

The SKI pressure treadle pump is mobile, allowing for easy use in large fields with multiple water sources and for relocation to secure locations when the pump is not being used. The pump can easily be coupled with a low pressure drip or sprinkler system.

The pump comes with a foot valve (allowing for easier priming), suction hose, and layflat for discharge hose.

Picture	Item	Quantity	Technical Specifications
BILL OF MATERIAL			
	Pressure Treadle Pump	1	Galvanized, inlet/outlet diameter: 50mm
	Rigid Suction Hose	2 x 1 meter	50mm
	Lay-Flat Outlet Hose	10 meters	LLDPE, 50mm diameter
	Check Foot Valve with Debris Screen	1	PE, 50mm diameter
	Wire Hose Clamps	6	Galvanized, 50mm diameter

SPARES AND TOOLS			
Installation Manual	1		
Spanners	4	Various Sizes	
Piston Cup	2	Nitrile Rubber	
Flapper Valve	2	Nitrile Rubber	

PRODUCT SPECIFICATIONS	
Overall Dimensions	With handle: 1.1 x 0.8 x 0.3 meters Pump head & frame only: 0.5 x 0.8 x 0.3 meters
Maximum Suction Depth	6-8 meters
Maximum Pumping Height	12 meters

* Assumes 80% irrigation efficiency and total pumping head of 3 meters
 * Assumes 2 hour sustainable exertion rate for an average pump user

SKI MOBILE PRESSURE TREADLE PUMP OUTPUTS	
Total Suction and Lift	Water Output (liters/min)
1 meter	80
5 meters	60
9 meters	30

PACKAGE AND WEIGHT	
Package	Delivered in two Carton Boxes
Package Size	54 x 45 x 45cm
Package Volume	0.243m ³ / 0.033m ³ / 276 liters (total)
Gross Weight	15.kg/ 13.5kg / 29kg (total)



25 LITER WATER BAG

PRODUCED BY: HARVEL AZUD, INDIA

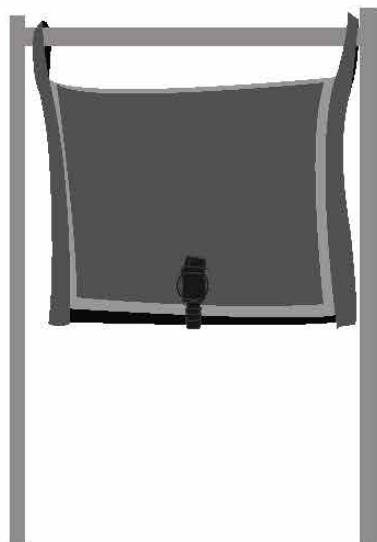

Water bags serve as a more affordable alternative to rigid barrels and tanks, and the collapsible and flexible bag is easy to ship and store. The 25 liter water bag can supply water to 20sqm drip irrigation systems or be used as a means for storing non-portable water. It can easily be filled using a treadle or engine pump or by bucket.

The 25 liter water bag is easy to set up – a supported elevated post can be used to suspend the bag. When using the water bag with a low pressure drip irrigation system, the bottom of the bag should be elevated at least 0.75 meters above the field.

The outer nylon liner is UV-resistant. The bag comes with a tap and valve to control water flow.

Product Specifications		Package and Weight	
Overall Dimensions (Flat Bag)	46 x 61cm	Package	Plastic Bag
Outer Liner	UV-resistant Woven Nylon Fabric, 350 micron	Package Size	2 x 3 x 5cm
Bag capacity	Minimum Lift Required for Gravity Feed	Field size (m ²)	Fillings required per day
25 liters	0.75 meters	20m ²	5-10

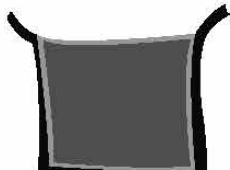
Bill of Material			
	1	25 Liter Header Water Bag	Fully assembled with inner liner; double stitched, UV-protected, two slings and covering flap.

* Assumes 80% irrigation efficiency and 4 to 8 mm crop evapotranspiration per day per square meter.



200 LITER WATER BAG

PRODUCED BY: HARVEL AZUD, INDIA

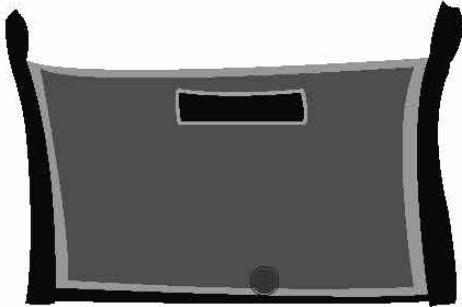

Water bags serve as a more affordable alternative to rigid barrels and tanks, and the collapsible and flexible bag is easy to ship and store. The 200 liter water bag can supply water to 100 or 200 sqm drip irrigation systems or be used as a means for storing non-portable water. It can easily be filled using a treadle or engine pump or by bucket.

The 200 liter water bag is easy to set up – a supported elevated post can be used to suspend the bag. When using the water bag with a low pressure drip irrigation system, the bottom of the bag should be elevated at least 0.75 meters above the field.

The outer nylon linter is UV-resistant. The bag is designed to be used with a bulkhead fitting to control water flow.

Product Specifications		Package and Weight	
Overall Dimensions (Flat Bag)	160 x 800cm	Package	Plastic Bag
Outer Liner	UV-resistant Woven Nylon Fabric, 350 micron	Package Size	10 x 21 x 30cm
Inner Liner	PE, 200 micron	Package Volume	0.006m ³ / 6 liters
		Gross Weight	0.8kg

Bag capacity	Minimum Lift Required for Gravity Feed	Field size (m ²)	Fillings required per day
200 liters	0.75 meters	100m ²	2-5
		200m ²	5-10

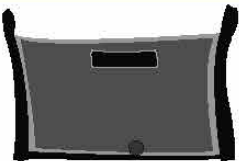
Bill of Material			
	1	200 Liter Header Water Bag	Fully assembled with inner liner; double stitched, UV-protected, two slings and covering flap

* Assumes 80% irrigation efficiency and 4 to 8 mm crop evapotranspiration per day per square meter.



1,000 LITER WATER BAG

PRODUCED BY: AGRICULTURE DEVELOPMENT COMPANY



Water bags serve as a more affordable alternative to rigid barrels and tanks, and the collapsible and flexible bag is easy to ship and store. The 1,000 liter water bag comes with a spout to be attached to a drip irrigation system.

This bag requires the user to build a stand/frame to support the bag, as shown in the schematic.

Bill of Material

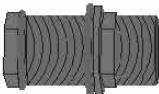
	1	1,000 Liter Water Bag	
	1	Tank Connector	