

How treadle pumps work

HOW THEY WORK

A treadle pump comprises a cylinder fitted with a piston and some means of pushing the piston up and down (Figure 1). A pipe connects the pump to the water source and at the end of this pipe is a non-return valve that allows water to enter the pipe and stops it from flowing back into the source. The piston and the cylinder must have a very close fit, so that when the piston is raised, it creates a vacuum in the cylinder and water is sucked into the pump. When the piston is pushed down, the water is pushed through a small valve in the piston to fill up the space above it. When the piston is raised again, it lifts this water until it pours out over the rim of the cylinder and into an irrigation channel or tank. At the same time, more water is drawn into the space below the piston. The downward stroke of the piston once again pushes water through the small valve into the space above the piston and the process is repeated.

This is a very simple principle that has been used for centuries for lifting water from streams and wells. The amount that can be lifted in this way is usually small, however, because pumps that use this idea are normally hand operated and the effort required to lift water is considerable. This has generally restricted their use to domestic purposes and for watering animals.

This idea has now been skilfully adapted for use in irrigation, where much greater volumes of water are needed. The most important innovation has been to change the driving power from arms and hands to feet and legs. These have much more powerful muscles and so are capable of lifting much more water. Two cylinders are used instead of one. They are positioned side by side and a chain or rope, which passes over a pulley or a rocker bar, connects the two pistons so that when one piston is being pushed down, the other one is coming up. Each piston is

Figure 1: Treadle pump operating principles

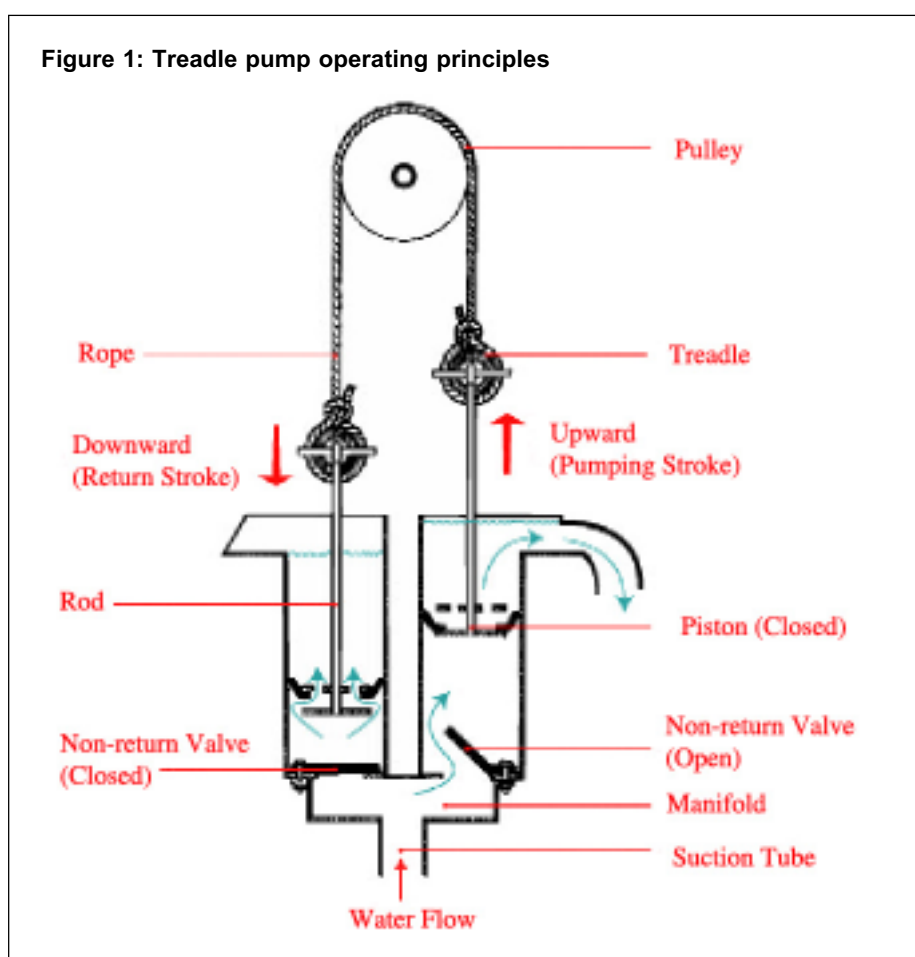

connected to a treadle. The operator stands on the treadles and presses them up and down in a rhythmic motion – like pressing the pedals on a bicycle. Some have also described it as similar to walking. This rhythmic method of driving the pump has gained wide acceptance among farmers and seems to be preferable to any mechanism that requires only one foot or arms and hands.

This pump has become known as the *suction pump* and it is used to draw water up from a well or river and discharge it into a canal for irrigation. But since its advent another form of treadle pump has been developed which is commonly known as the *pressure pump*. This operates on exactly the same principle as the suction pump but the delivery end has been modified so that water can be fed into a pipe rather than an open channel. Instead of water flowing over the top of the cylinders into a channel, the upward movement of the pistons pushes water through a second valve into a delivery pipe. This valve closes on the downward stroke to stop the flow from reversing. In this way it is possible to maintain a pressure in the delivery pipe that can be used to drive sprinklers or drippers or deliver water to a header tank. Hence the name *pressure pump*.

These are not the ideal names, because they imply that the two pumps are different, when in reality they both work on the same suction principle. However, these are the names that have been generally accepted and so in accordance with common use they are used throughout this manual.

SOME BASIC HYDRAULICS

Many professionals without an engineering background often do not have a good understanding of basic hydraulics and pumping. This section is designed to clarify some of the important issues such as pressure, head and discharge and what is meant by such terms as suction lift and delivery head.

Pressure and head

Pressure is defined as a force acting uniformly over an area. It is normally measured in kilo-Newtons per square metre (kN/m^2). In some European countries, kilograms force per square centimetre (kgf/cm^2) is still used. Another common unit is the bar. One bar is the equivalent of atmospheric pressure and is equal to 1 kgf/cm^2 . Many non-engineering professionals find kilo-Newtons confusing and much prefer to work in kilograms force (kgf), as it can be easily related to the common understanding of kilograms as a measure

of weight. This is the unit of measurement used throughout the manual.

Pressure is often referred to as a *head of water*. To understand this, imagine a long vertical tube, in which the pressure is to be measured, connected to a pipe. Water will rise up the tube, because of the water pressure in the pipe. The height to which it will rise is a measure of the pressure. This is called the head and is another way in which pressure is expressed. It has the advantage of allowing changes in land topography that can affect pumping pressure to be taken easily into account when working out pressure requirements. It must, however, be linked to the fluid in the pipe, as different fluids would rise to different heights because of their different densities. So the correct term to use is head of water. The relationship between pressure and head is a simple one:

$$\begin{aligned} \text{Head of water (m)} &= 0.1 \times \text{pressure (kN/m}^2) \\ &\text{or} &= 10 \times \text{pressure (kgf/cm}^2) \\ &\text{or} &= 10 \times \text{pressure (bar)} \end{aligned}$$

As an example, a pressure of 3 bar or (3 kgf/cm^2) would result in water rising to a height of 30 m in the tube. (For more explanation of pressure and other aspects of hydraulics, see Kay, 1998.)

Atmospheric pressure, which is important for pumping water, is equal to 10 m head of water. The reasons for its importance are discussed in the next section.

Suction lift

For operating convenience, pumps are usually located above the water source and a short length of pipe is used to draw water into the pump. This is called the suction pipe. The difference in height between the water surface and the pump is called the *suction lift*. The idea of suction lift and its limitations is one that is not well understood, so a word of explanation is perhaps appropriate here.

Pumps do not actually suck water, as is often imagined. A pump takes water from the source in much the same way as you would suck up water through a drinking straw. In fact you do not actually suck up the water; you suck out the air from the straw and create a vacuum. Atmospheric pressure does the rest, pushing down on the water surface and forcing water up the straw to fill the vacuum. Atmospheric pressure thus provides the driving force but puts a limit on how high water can be lifted in this way. It does not depend on the ability of the person sucking. At sea level, atmospheric pressure

is approximately 10 m head of water, so in theory it can push water up to 10 m. But if you were relying on a straw 10 m long for your water needs, you would die of thirst! A 7 m straw would improve your chances of survival and 3 m would be even better. In other words the shorter the straw, the easier it becomes to get water.

This principle applies to all pumps, including motorized pumps and treadle pumps. Ideally, it should be possible to lift water by suction up to 10 m. In practice, a sensible limit is 7 m, because of friction losses in the suction pipe and the effort required to create a vacuum under these conditions. Even at this level, there will be difficulties in keeping out air from leaky pipe joints and seals to maintain the vacuum. The lower the suction lift, the easier it will be to operate the pump.

The question of how to lift water from a borehole deeper than 7 m often arises. Clearly, in this situation, water cannot be lifted by any pump operating at ground level. The only way to deal with this problem is to lower the pump into the ground, so that it is less than 7 m above the water surface. This can be done either by using a submersible pump – in which case the pump is below the water level, so there is no suction – or excavating down and placing the pump on a shelf within 7 m of the water surface.

For pumps operating at high altitudes, where atmospheric pressure is less than at sea level, the practical limit will be lower than 7 m.

Total pumping head

Total pumping head is another term that needs careful use. It is the sum of the *suction lift* and the *delivery head* and is more important for the pressure pump. The delivery head is the pressure created on the delivery side of the pump; it is measured from the pump to the point of water delivery. So if the suction lift is 4 m and the pump then delivers a 7 m head to some sprinklers or hose pipe, the pumping head would be 11 m. This represents the total height through which the water must be lifted from source to delivery point. If 11 m were the maximum that a pump could deliver, any change in the suction lift would affect the delivery head. For example, if the suction lift increased to 6 m, then the delivery head would reduce to 5 m, resulting in the same total pumping head of 11 m. Just quoting delivery heads without any reference to suction lift does not provide enough information about what a pump can do in terms of pressure.

In many pumping installations, the total pumping head would include any losses in head resulting from friction in the suction pipes and losses as the water flows through filters and valves. Flow through treadle pumps is low, so for simplicity these effects have been ignored.

Remember: Total pumping head is the suction lift **plus** the delivery head.

THE BASIC COMPONENTS

Although there are different designs of treadle pump available, there are several components which they all have in common (Figure 2).

Pump cylinders

The use of two pump cylinders provides a nearly continuous flow of water. Although this is not so important for gravity irrigation, it can be an advantage for pressurized irrigation, where the build up of pressure is important to create a spraying action. Cylinders are normally between 75 mm and 150 mm in diameter. A common diameter is 100 mm.

Materials used include steel plate bent into a cylinder, PVC pipe, concrete and bamboo. The choice of material is strongly influenced by local availability and cost. Steel is a good choice if there are sufficient skills and machinery available to bend it into the right shape. Bamboo has been used where it is plentiful. It has the advantage that it can be maintained at farm level, but it does have a short working life. It is not suitable for pressure pumps.

Pistons

Pistons move up and down in the cylinders when the operator presses down on the treadles. Steel rods connect the pistons to the treadles. The pistons can be made of steel, wood or plastic, with leather or rubber cups or rings to form the seal with the cylinders. The seals must also stand up to the rigours of continually moving up and down against the cylinder wall (see Table 5 for tests on seals).

Pump manifold

The manifold is a steel box in a pressure pump that connects the inlet and outlet pipes to the pump cylinders. It comprises two parts: the inlet side, which allows water into the cylinders, and the outlet side, which allows water to exit from the cylinders into a delivery pipe. The suction pump only has an inlet

Figure 2: The basic components of a treadle pump

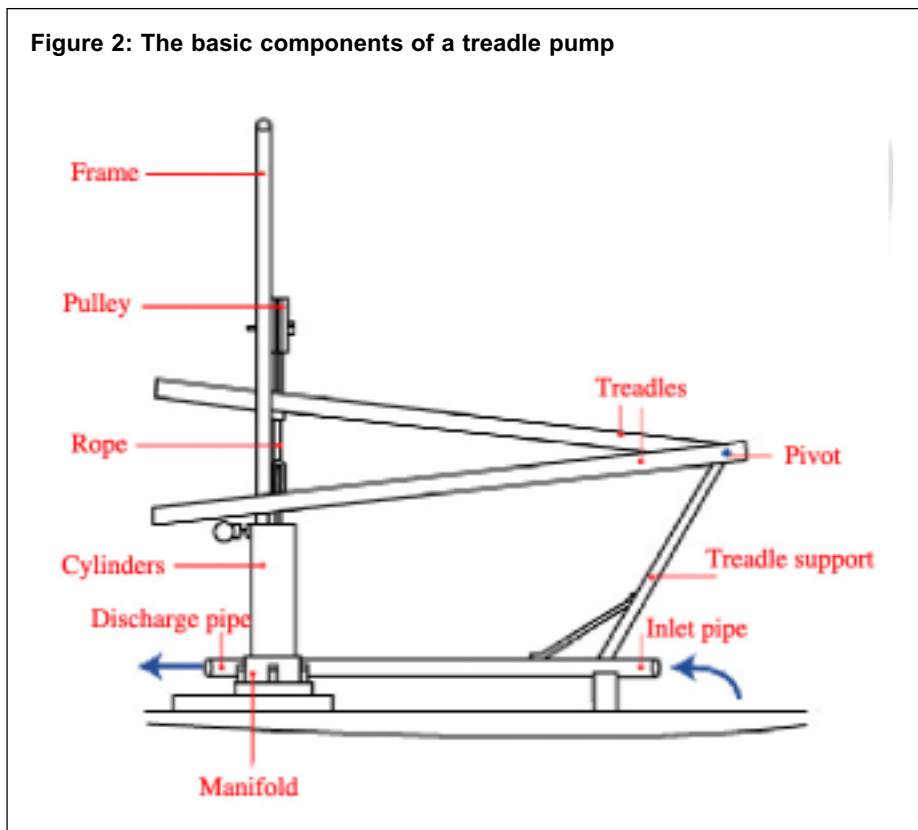

manifold, as water spills over the top of the cylinders via a spout and discharges into a channel.

Non-return valves

Non-return valves allow water to flow one way and stop it from flowing back to the source. Treadle pumps can have several non-return valves. One can be located at the entrance of the suction pipe to stop it from draining every time pumping stops. Interestingly, very few pumps use this valve, which means that the pump must be re-primed every time pumping begins. A second valve is located at the top of the suction pipe in the inlet manifold to stop reverse flow during pumping. Pressure pumps have a third non-return valve in the outlet manifold, to stop reverse flow once the water has been pressurized.

Treadles

The operator stands on the treadles and pushes them up and down to work the pump. They can be about 1 metre long, hinged at one end and supported at the other by a rope or chain running over a pulley. They are connected to the piston rods so that the movement of the treadles is transferred to the pistons. Treadles can be made from steel, wood or bamboo. Treadles need to be strong enough to take the forces applied by the weight of the operator.

Pulley wheel or rocking bar

The pulley wheel and rope connect the two treadles and enable the operator to work the treadles up and down in a reciprocating movement. The pulley is usually made of wood soaked in oil to preserve it and to lubricate the movement. An alternative to the pulley is a rocking bar, which is pivoted in the middle (see ApproTEC pumps – Kenya).

Frame

The components of the treadle pump are mounted on a frame, which keeps all the parts together and provides support for the operator. Some pump frames are made from wood and are very portable. This can be important when security is a problem and pumps cannot be left in the field overnight. However, some designs use sturdy metal frames which can stand up to the rigours of continual use; one design is encased in concrete (see Swiss “concrete” pump) which makes it difficult to move and hence difficult to steal.

PUMP DESIGN FEATURES

Treadle pumps provide one of the best ways of using human power to lift water. Sizing of the components and careful design are essential to ensure that this is done in the most efficient manner. Pump output requirements of discharge and pressure must be

matched with the mechanical components, such as the diameter of the pistons, their stroke length, the weight of the operator and the cadence – the frequency with which the treadles are pushed up and down. This process of design is complicated by the wide variations of possible pumping needs of different sites and the wide range and ability of operators, who must be comfortable when using the pump and not bent over in some awkward position. The design must be as simple as possible in terms of its manufacture and maintenance. This section looks at these issues and explains, for example, why some treadle pumps have small diameter cylinders while others have large ones.

Human power – what can be achieved?

It is generally accepted that a reasonably fit, well-fed human being between 20 and 40 years old can produce a steady power output of around 75 watts for long periods (Fraenkel, 1986). This may not be the case in many developing countries, so a more realistic output may be around 30 to 40 watts. This power is transferred to the pump when the operator stands with one foot on each treadle and pushes them up and down in a reciprocal motion. This is a very natural movement for the human body; it can be sustained for several hours, if the parameters of stroke length and the cadence are matched with the ability of the operator.

A steady output of 75watts is the equivalent of walking up stairs at home in 20 seconds. This may not seem such a difficult task but try doing it continuously for 4–6 hours each day.

Assuming a 75 watt output, it is possible to calculate what can be done with this human power. In theory, if a suction pump has a suction lift of 1.0 m, then 75 watts would produce a discharge of 7.5 litres/second. At 2.5 m suction, this would fall to 3 litres/second and at 5 m it would be 1.2 litres/second. As the suction lift increases, the discharge that can be achieved decreases. It is not possible to convert all the 75 watts into useful water pumped: some will inevitably be lost through friction in the pipes and in the pump and valves. Introducing an efficiency factor of 50 percent for the conversion of human power into water power would reduce the discharge at 2.5 m suction from 3 litres/second to 1.5 litres/second.

Fraenkel (1986, p.137) summarizes this by calculating the discharge and head for an input power of 75 watts at 50 percent efficiency as shown in Table 4.

Table 4. Discharge and head

Head (m)	0.5	1.0	2.5	5.0
Discharge (litres/sec)	7.6	3.8	1.52	0.6

Of course, if two people operate the pump at the same time, as is often done in some countries, then obviously the input power and the output in terms of pressure and discharge will be much greater.

This puts upper limits on what can be realistically achieved with human power.

Remember! There is no such thing as a free lunch. If you want to lift a given quantity of water from a given depth, you must provide the human power to do it. The pump just provides a more efficient means of converting human power into waterpower. But there are limits to what can be achieved.

Pump ergonomics

Ergonomics is the science of matching people with machines – in this case matching operators with treadle pumps. In this way, the pump component sizes and dimensions are chosen to get the best out of the human power input and ensure that the pumps are comfortable to operate.

Piston/cylinder diameter

Pistons and cylinder diameters range between 75–150 mm, with 100 mm being a common choice. Piston diameter puts an upper limit on the pressure that can be achieved (see Discharge).

Stroke length

There are two stroke lengths to consider: the foot stroke length and the piston stroke length. The foot stroke length is the vertical distance between the feet when one foot is raised and the other is at its lowest point. If the stroke is too short, the leg muscles tire quickly; if it is too long, the leg muscles are straining. Bicycles are one of the best known ways of using human leg power. The distance between bicycle pedals is approximately 340 mm, which would be a long stroke for a treadle pump and the pumping speed (cadence) would be slow. The stroke is governed by what is a comfortable speed to operate the pump. A stroke length of 100–350 mm is a typical range but it depends on how the pump will be used. Given a choice, an operator would normally choose a short stroke length for high heads and a longer stroke for low heads.

The piston stroke length is the vertical distance through which the piston moves during pumping. On

some pumps this is the same as the foot stroke length but this is not always the case (see Mechanical advantage).

Piston stroke volume

This is the volume of water lifted during each stroke of the pump. It can be calculated by multiplying the area of the piston by the piston stroke length.

Cadence

This is the frequency with which the treadles move up and down. A cadence up to 60 cycles per minute is a comfortable speed for most operators. This determines the pump discharge, which can be calculated by multiplying the piston stroke volume by the cadence. It is important to make sure the units are all the same to get an accurate result in litres/second. Pump cadence is variable, as it depends on the individual operator. Pump discharge will vary as a result of this.

Foot force

The total pumping head is created by the force on the piston from the operator pushing down on the treadle. For comfortable pumping, this downward force should not exceed 50 percent of the operator's weight and not more than 70 percent for short periods. For the pump to be suitable for men, women and children and for a range of pumping heads, it should be designed for a foot force of 15-50 kgf (150-500N). The piston force must also overcome the friction in the cylinders and in the pipes.

Mechanical advantage

On many pumps, it is possible for operators to move their position along the treadles, so that they can change the force needed on the pistons while maintaining a steady and comfortable foot force. This movement also means that the pump can accommodate operators of different weights, each able to find a suitable and comfortable pumping position. This is an important aspect of pumping: it can be much less tiring when operators can change their position, rather than trying to produce a particular force at a fixed position on the treadles.

In mechanical terms, this positioning of an operator relative to the piston is based on the lever principle. When an operator is standing on the treadles immediately above the pistons, the pushing force is directly transferred to the pistons. An operator's downward force of 30 kgf (300 N) thus transfers directly a force of 30 kgf to the piston (Figure 3-1). If the operator moves away from this

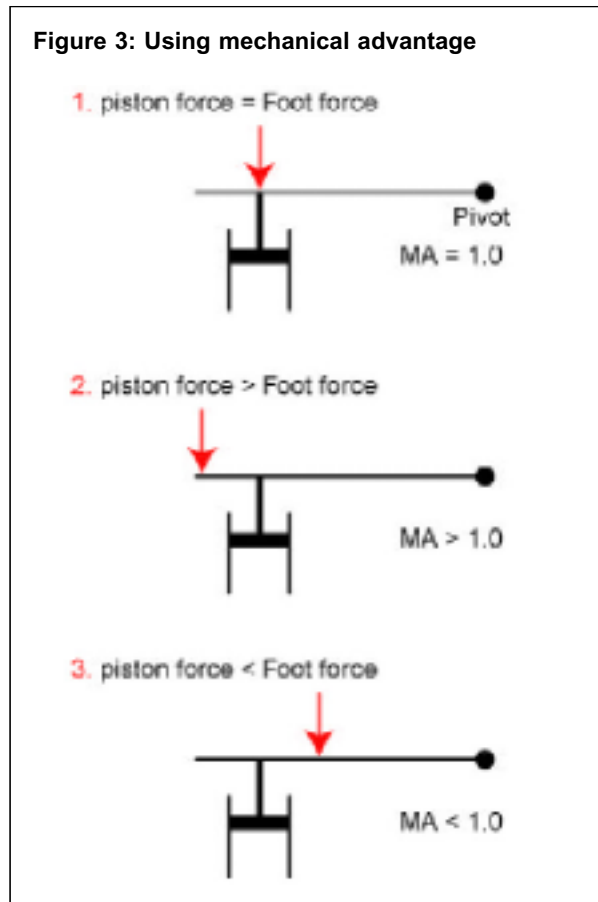

position and increases the distance from the pivot point of the treadles, a greater force can be applied to the pistons. For example, if the distance from the pivot point to the piston is 1 m and the distance of the operator from the pivot is 1.2 m, a downward force of 30 kgf would increase to a force of 36 kgf on the piston (Figure 3-2). The converse is also true. If the operator moves to reduce the distance to the pivot point to 0.8 m, the downward force on the piston also reduces to 24 kgf (Figure 3-3). This ratio of the distance of the operator and the piston from the pivot point is known as the mechanical advantage. In the first case it has a value of 1.2 and in the second 0.8.

Although mechanical advantage is described above in terms of the position of an operator, it has a direct bearing on the movement of the operator, in terms of foot stroke length and piston stroke length (Figure 4). A mechanical advantage of 1 means that the foot stroke length is equal to the piston stroke length. If the mechanical advantage is increased to 3, the piston stroke would be only one third of the foot stroke length. As the stroke length of the operator is limited to approximately 350 mm, the piston stroke length would be one third of this, i.e. 115 mm.

In practical terms, this means that a light operator, such as a child, could operate a pump by standing as

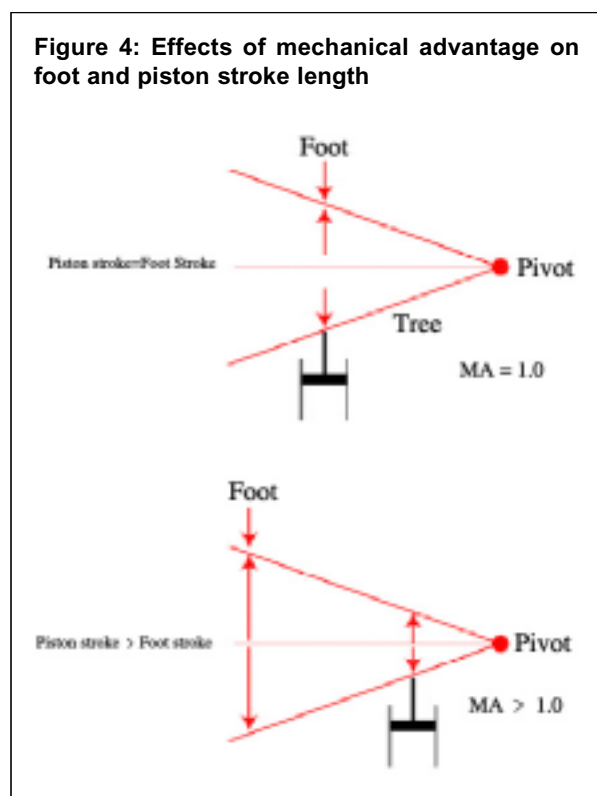

far away as possible from the pivot, to take advantage of the extra leverage. A heavy, or strong operator could move closer to the pivot for a comfortable pumping position. It also means that greater pumping pressures can be achieved because of the greater forces but this is at the expense of volume lifted per stroke, because of the reduced piston stroke length.

Suggested mechanical advantage ranges between 0.5 to 4. But there is a practical upper limit to this advantage, as the pump might overturn if the operator stands at the extreme end of the treadles.

A summary of desirable features

A summary of the range of desirable design features is shown in Table 5.

Table 5. Desirable features

Item	Details
Piston diameter	75-150 mm
Foot stroke length	100-350 mm
Cadence	As chosen by the operator
Foot force	15-50kgf (150-500N)
Mechanical advantage	From 0.5 to 1 up to 4 to 1
Treadle spacing	175-200 mm

Discharge

The concept of discharge is familiar to most people who deal with water. Almost the first question that is asked of a pump is – What discharge can it produce?

Discharge can be measured in many different units, e.g. litres/second, cubic metres per hour (m^3/h) or gallons per minute. It is a measure of the volume of water flowing per unit of time. For treadle pumps, the same question is asked but the answer is not so straightforward. This is because most treadle pumps do not produce a continuous steady flow and the output depends so much on the operator. To say that a treadle pump can produce 2 litres/second needs to be qualified with how the operator achieves this. It may be a heavy or a light operator. It may even be two operators working together on the same pump. It may be a continuous steady flow but is it sustainable over long periods or is it a high flow only achievable in short bursts of high power input? Did the operator work a typical day of, say, six hours and take rests for ten minutes every hour or swap with another operator?

There is clearly a need to standardize the method of measuring discharge if it is to have meaning for comparing pump performance and for choosing one that is suitable for a particular job. This is not the present situation. In this manual, different ways of assessing discharge values are used by different investigators. Some discharges are measured under laboratory conditions, with information given about the operator's ability. Some are measured in the field and make allowances for rest periods, giving an average discharge over the day. Some quote the discharge based on the amount of water pumped over a longer period of time and work out the sustainable discharge over that period. This is not to say that one method is the right way. There are several ways of doing it, and so one must be careful to compare like with like.

One way to compare pumps is to look at the volume per stroke. This indicates what can be lifted but does not include the ability of the operator.

Remember! Discharge values quoted for treadle pumps can be misleading. Note how they are measured and see if they are sustainable over long periods, before basing your irrigation strategy on the values given.

Achievable pressures

The range of desirable features and the limits on human power restrict what can be achieved in terms of pressure. The maximum pressure or head that can be achieved by an operator depends on the downward force on the piston and its area. Pressure is the force per unit of area, so for a given force, if the area is increased, the pressure decreases and vice versa. A 65 kgf operator standing on a treadle immediately

above a piston of 100 mm diameter could only produce a maximum pressure of 6 m head, no matter how hard he tries to push. If the diameter were reduced to 75 mm, the maximum pressure could be increased to 15 m head.

Another and more efficient way of increasing the pressure is to increase the mechanical advantage. This is the approach that ApproTEC and the Swiss have used in the design of their pumps (see ApproTEC pumps – Kenya and Swiss “concrete” pump). Increasing the mechanical advantage from 1 to 4 on a 100 mm diameter piston with the same 65 kgf operator would increase the maximum achievable pumping pressure to 24 m.

The pressures quoted above are somewhat higher than can be achieved in practice, as these are simple demonstration calculations based on 100 percent efficient transfer of force from operator to water. In practice there are losses. First, it is not possible in a normal pumping situation to transfer all the body weight to each treadle; it is perhaps only 70 percent at most. Second, there are friction losses in the pump to overcome. The maximum pumping head of 24 m referred to above would, in practice, only be 14 m.

If pressure is important, by far the best way of achieving it is to increase the mechanical advantage. This is balanced by a lower volume per stroke.

Priming and its limits

When a pump is first used, it must be primed. This is a process of removing all the air from the suction pipe and the cylinders. If this is not properly done, pockets of air left in the system will impair the performance of the pump.

Priming can be achieved in a number of ways. The simplest way is to draw the air out by normal pumping action. Some pumps have a non-return valve at the entrance to the suction pipe, so that it does not drain when it is not in use. When the pump starts up again, it is already primed and ready to go. Unfortunately, very few treadle pumps have this feature. Another approach is to fill the pump and the suction pipe with water prior to pumping.

Whichever way priming is achieved, the main objective is to get all the air out of the system. This can be difficult, because during pump start-up the seals are all dry. Air leaks more easily past a dry seal than a wet one, so wetting the seals before pumping can greatly improve priming.

Small quantities of air in the cylinders can stop a pump from priming, particularly when the suction lift is high. This is because air is several thousand

times more compressible than water. During priming, when a piston is at its lowest position, the space between the piston and the bottom of the cylinder will be full of air (Thomas, 1993). This is called the dead space. When the piston begins to rise, the pressure below the piston falls but it does not immediately start to suck up water. The air starts to expand and the air pressure drops (Boyle’s law: $pV^{1.2} = \text{constant}$). Only when the piston has moved a considerable distance will the pressure have dropped enough to be below the suction pressure and so open the inlet valve to allow water into the pump. Thereafter, the piston does a useful job, drawing air (and below it water) up the suction pipe. This means that if there is a significant volume of air in the cylinder and a high suction lift, the operator may not be able to draw water but will simply be expanding and compressing the air in the cylinder. The operator may never be able to get the pressure low enough to draw water.

This problem is most acute during priming when the pump is dry. The volume of air relative to the swept volume – the volume swept by the piston – can be quite high. For piston pumps, this ratio can exceed 1, i.e. the volume of air is equal to the volume swept by the piston. In such cases, it will not be possible to prime the pump when the suction head exceeds 5.5 m. Effective priming depends on keeping the ratio below 1 and the suction lift as low as possible.

Some manufacturers quote operating suction lifts as high as 8 m but for many pumps it will be physically impossible to prime them by normal suction methods at this depth. Only those pumps manufactured to a very high standard will be able to achieve this.

When the pump is primed and running normally, the whole cylinder is filled with water and the seals are wet, so the air volume will disappear or be considerably reduced. At this point, the phenomenon will no longer be a problem. It does, however, highlight the problems of priming and the need for airtight connections in the suction pipes. Every little leak can add to the problem of priming and the greater the suction lift the greater will be the problems of leakage.

PERFORMANCE

Pumps are normally described by their hydraulic performance, which indicates the discharge and pressure that can be expected for the effort (or power) put in. For treadle pumps, this is not an exact science

because of the difficulty of standardizing the power input, which depends on the physical strength of operators and their ability to sustain this power over a period of time.¹ Comparison between pumps from different suppliers is also made difficult because of differences in design, e.g. materials used, dimensions of components and standards of workmanship.

This section reviews several different pumps available in Africa, bringing together the information currently available on their performance. A summary is then made to try and answer the question: which is the best pump? Or more appropriately: which is the best pump for me? The latter is the more important and answerable question, because much depends on the circumstances in which the pump will be used. This will become clearer as the review proceeds.

There are many treadle pumps in use throughout the world. Many designs have been modified from the early Bangladesh model to take advantage of local conditions and materials. Data are presented here on six pumps – the original treadle pump from Bangladesh, four that are being widely used in Africa and a recent innovation from Switzerland:

- Bangladesh pumps
- IDE Pumps – Zambia
- Masvingo pumps – Zimbabwe
- Enterprise Works pumps – The Niger
- ApproTEC pumps – Kenya
- Swiss “concrete” pumps

Bangladesh pumps

These pumps have been included in this review because they were the first treadle pumps, on which all the others were based. They were developed in the late 1980s in Bangladesh and, as already mentioned previously, were called tapak-tapak or TT pumps because of the noise they made. The original pumps were constructed predominantly from bamboo at the very low cost of US\$8 (at 1986 prices). An improved version of this early treadle pump was developed in the Philippines by the International Rice Research Institute (IRRI), which increased the price to US\$25 (at 1987 prices).

Several improved models were built with more robust materials and tested in Bangladesh. Cylinder

diameters ranged from 76 mm to 178 mm, with a piston stroke length of approximately 290 mm. Extensive testing was done by the Rangpur Dinajpur Rural Service (RDRS) and the results published in Orr *et al.*, 1991. They indicated that output from a pump depended on a variety of factors, including suction lift, cylinder diameter, variations in internal friction, occasional air leaks in the installation, hard filters, skills and care of the installation team and the weight and agility of the operator.

A summary of the test data in Table 6 shows the sustainable output for a range of pump sizes with an indication of the suction range over which the pumps operate satisfactorily. The authors describe this as the optimum range. A 76 mm pump is capable of maintaining a discharge of 1 litre/second up to a suction limit of 8.5 m. It is likely to be more at lower suction lifts but this is not reported. The sustainable discharge increases with pump size but the recommended suction lift reduces, presumably so that the effort being put in by an operator is similar in each case. The reduced suction lift is compensated by increased discharge. The sustainable discharge of the larger pumps, up to 5 litres/second, is significant but the authors stress that this is only achievable at very low suction heads. Only suction lift is quoted and not pumping head, because this pump is not a pressure pump and so in effect the delivery head is zero.

There was no indication of the piston stroke length in these data. Construction details shows that the cylinder length is 303 mm, so a stroke length of 290 mm has been used to calculate the volume of water pumped from each cylinder per stroke.

Orr defines sustainable discharge as the flow produced by two to three medium weight operators pumping in shifts all day long. The authors report that higher discharges can be achieved using heavier operators and increasing the speed of pumping. The heavier operators would be able to exploit the larger pumps that require more effort; they would also be able to use them at greater suctions. Greater discharges can be expected when two people operate a pump at the same time, as is often the case in Bangladesh.

Orr reported on an independent World Bank study (*Engineering and power consultants*, 1987) that defined the effort needed to work treadle pumps in terms of power input. At 30 field sites throughout Bangladesh, engineers measured the power required to operate a treadle pump, expressing it in watts over the Basic Metabolic Rate (BMR). The average BMR is 62 watts. This is the barest minimum demand,

¹ Power and energy are often confused. They are related but have different meanings. Energy is the capacity to do useful work, whereas power is the rate of using energy, measured in Watts. The amount of energy used depends on how long the power is applied. Hence, energy is power x time, measured in Watt-hours.

Table 6. Discharges for different pump cylinder diameters (Orr *et al.*, 1991)

Pump cylinder diameter (mm)	76	89	120	152	178
Suction lift (m)	7–8.5	5–7	2.5–5.5	2–2.5	0.5–2
Sustainable discharge (litres/sec)	1	2	3	4	5
Volume per stroke* (litres)	1.25	1.7	3	5	7

Table 7. IDE pump performance data, Zambia

Pump type	Suction lift (m)	Discharge for different suction lifts (litres/sec)					Delivery head (m)
		1 m	2 m	4 m	6 m	8 m	
Tube well	1–8	2.5	2.0	1.2	0.8	0.5	0
Modified	1–8	2.5	2.0	1.2	0.8	0.5	0
River	1–8	2	1.5	1.0	0.8	0.3	0
Pressure	1–4	2.5	2.0	1.6	0.5	n/a	7

equivalent to lying in bed and doing nothing. The results showed that a comfortable pumping activity required a power of 30 to 50 watts above BMR.² Pumping continuously for 20 minutes and then resting for 10 minutes, a healthy adult male could work comfortably for 5–6 hours a day. So pumping 1 litre/second with a suction lift of 3 m for 40 minutes in every hour produces an average discharge of 0.66 litres/second (2.4 m³/h). Working at this rate for 6 hours a day would mean that up to 14 m³ of water could be pumped. When the suction lift was increased to 5 m or more, however, the average discharge fell by 50 percent, i.e. to 0.33 litres/second (1.2 m³/h), because of the increased effort. This clearly demonstrates the importance of the suction lift in determining the pump discharge.

Although Orr's report does not discuss the significant difference between the RDRS discharge results and those obtained in the field tests, the explanation might simply be the difference between what happens in the laboratory and what happens in the field. Orr does quote details from the field study, which seemed to be quite comprehensive from the measurements taken. On this basis, it would be best to make judgements on performance from the field data, bearing in mind that more can be achieved if the conditions are favourable.

One aspect of the Bangladesh situation is the tendency for two operators to be working the pump at the same time. This would clearly make a difference to pump performance and would account for some of the high discharges reported. Remember that there

is a limit to what an individual can achieve in terms of power output and therefore water lifted (see Human power – what can be achieved?).

The Bangladesh design has a low mechanical advantage between 0.8 and 1.2. Generally, operators stand close to the pistons, so the piston and foot strokes are approximately the same at 290 mm. However, the mechanical advantage range does allow for operators to move their position relative to the pivot point in order to find a more comfortable pumping position, depending on their weight and the head and discharge required.

IDE pumps – Zambia

IDE introduced the Bangladesh pump into Zambia as part of a project to support and develop small-scale irrigation (see The Zambia experience on p. 28). They now produce four different types of treadle pump, the Tube well, Modified, River and Pressure pumps, to meet various needs. The performance data obtained from IDE in Zambia are shown in Table 7.

Cylinder diameter is 89 mm and stroke length is approx. 300 mm (based on the cylinder length of 313 mm). This means that the volume of water pumped per stroke is 1.78 litres.

The Tube well, Modified and River pumps, as they are known, are suction pumps that have been modified to suit the site conditions around the water source. They have twin 89 mm cylinders with a spout outlet on the delivery side. The pressure pump is a modification to the suction pump that allows it to deliver a pressurized flow. It is similar to the Bielenberg pump (see Enterprise Works pumps – the Niger, on p. 40). IDE quote a range of recommended suction lifts and discharges that can be expected. They indicate that an average adult can operate the pumps

² Note that this is much less than the 75 Watts referred to earlier but it is a more realistic level of inputs for a Bangladeshi farmer.



Figure 5: IDE modified river pump, Zambia

easily for five to six hours in a day. Optimally, the pumps discharge about 1.5 litres/second between 1-8 m suction lift and a maximum of 2 litres/second at lower suction lifts. In emphasizing the importance of the operator in achieving the desired output, IDE say that the pumps do become hard to operate at suction lifts greater than 6 m.

IDE recommend the pressure pump for use only at low suction lifts, between 1-4m.

The suction pumps have a cylinder diameter of 89 mm. Assuming a stroke length of approximately 300 mm, the volume of water pumped per stroke is 1.78 litres. The stroke length is estimated from the cylinder length of 313 mm.

The pressure pump has a cylinder diameter of 100 mm, which increases the volume per stroke to 2.25 litres. Reports suggest that this pump is difficult to operate because of the tightness of its leather seals and it sometimes needs two operators to work it properly. Judging by the high volume per stroke and the small mechanical advantage it may well be that the pump is not so well designed for this purpose if only one operator is available. Two operators working at the same time would make the pump much easier to use, particularly when higher pressures are needed. Operators can also move their position on the treadles to vary the mechanical advantage but this is limited to between 0.8 and 1.2.

Non-return valves are not fitted at the entrance to the suction pipe on the IDE pumps, so there will be difficulties in maintaining prime between periods of pump use. Priming the pressure pump has been described as very cumbersome.

Masvingo pumps – Zimbabwe

Masvingo pumps are pressure pumps, very similar in construction to the IDE pump used in Zambia. The cylinder diameter is 100 mm but the cylinder length, and hence the stroke length, is slightly shorter. They are manufactured in Masvingo – hence the name – and several have been thoroughly tested by the Institute of Agricultural Engineering in Harare (1988). The resulting performance data are summarized in Figure 6. The pumps are reported to produce a discharge between 1-2 litres /second with a suction lift up to 5.5 m.

Cylinder diameter is 100 mm and stroke length is approx. 290 mm (based on a cylinder length of 300 mm). The volume pumped per stroke is 2.2 litres. Note that only suction lift is quoted, even though the pump is of the pressure type.

One of the main objectives of the tests was to see how various pump modifications stood up to long

Figure 6: Pump performance data for Masvingo pump, Zimbabwe

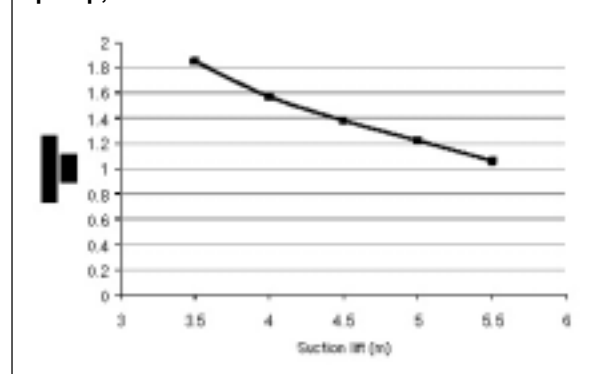



Figure 7: Masvingo treadle pump (pressure delivery), close-up of under-side

hours of use. Three types of piston and seal were tested: a leather cup with metal spacer, a leather cup with a wooden spacer and a PVC end cup with two “O” ring seals. All were run for 800 hours and the performance measured every 50 hours. The results showed that there was little difference in the discharge-suction lift characteristics and that this was maintained over the 800 hours. Differences in the performance of the pistons were observed, however (Table 8).

Data are not available on the power inputs, although it is assumed that only one operator was using the machine at any one time. No measurements have yet been made on performance in the field.

This pump allows an operator to change position and so vary the mechanical advantage between 0.8 and 1.2.



Figure 8: Masvingo treadle pump (pressure delivery), under test at manufacturers

Enterprise Works pumps – the Niger

Enterprise Works is an international NGO working in irrigation development in the Niger (see The Niger Experience). It used to be known as AT International, under which name it produced the book *How to make and use a treadle irrigation pump*, published in 1995 by IT Publications (see References). The Enterprise Works pumps are based on the Bangladesh model but modified for pressure delivery.

Table 8. Comparative performance of different piston types

Pump piston modification	Outcome
Leather cups with metal spacer	No problems during test except that it was difficult to operate. Leather cups did not produce a tight seal. Cups needed replacement after 400 hours.
Leather cups with wooden spacer	No major problems mechanically but all the operators reported that it was the most arduous to operate. Very difficult to prime after 750 hours of operation, because of air leakage around leather cups.
PVC end cups with two “O” ring seals	This was the easiest pump to use, because of the reduced friction from the PVC rings. But there were several breakdowns as the ring became damaged or dislodged from its seating. Also difficult to find ready-made rings to fit available pipe sizes.



Figure 9: Bielenberg pump, Niger

The Bielenberg pump, named after one of the authors, was developed from a pump designed for the United States Agency for International Development (USAID) by Dan Jenkins and known as the Universal treadle pump. This in turn was derived from the Bangladesh suction treadle pump. The early Bielenberg pumps were designed for suction lift as well as pressure but the publication referred to above describes only the pressure version. They were designed for easy manufacture in small African workshops, using commonly available materials and equipment, and to be light enough to be carried by one person between wells or different fields.

The standard Bielenberg pump has cylinders with a diameter of 100 mm. It can be inexpensively retrofitted with smaller cylinders by inserting high-pressure PVC liners in the cylinders and installing smaller diameter pistons and leather cups. This makes it easier to operate when the total pumping head exceeds 10 m.

The pumps being used in the Niger are based on the Bielenberg suction and pressure pump designs. Pressure pumps are not so important in the Niger, because of the limited range of topography.

Improvements have been made to the valves to enhance pump operation. The suction pumps have a non-return valve in the base of the cylinder and a valve in the piston. During the downward stroke, water passes through the valve to fill up the space above the piston. On the upward stroke, the water pours over a lip into a canal.

Three 100 mm diameter cylinder models are produced: a suction pump, a pressure pump and a hand-operated pump. All of them can be used by one or two operators. The foot and piston stroke of the pumps is approximately 250 mm, with mechanical advantage between 0.8 and 1.2 but in practice most operators do not use the full stroke and are most comfortable using a stroke length between 150 and 200 mm.

Enterprise Works' method of testing is based on field trials, as it is suggested that this is the only way in which a true measure of sustainable output can be obtained. Field testing over an extended period also allows for the averaging of the variable power input from the operators. For this reason, Enterprise Works characterize treadle pumps by measuring the average discharge that can be sustainably pumped by an operator under practical field conditions over an extended time period. Pump performance was measured at field sites with varying watertable depths, i.e. varying suction lifts. Preliminary results show that sustained discharges of 1.4-1.9 litres/second (5-7 m³/h) are possible with one or two operators from watertable depths ranging from 3 m down to 6 m. The operators can also adjust their position on the pump to increase the leverage and take account of the increased effort needed at greater suction lifts.

No measurements of maximum pressure have been made on the pressure pumps, as this has not been an issue in the Niger. However, it is anticipated that the pressure pumps can produce a total pumping head in excess of 8 m.

Enterprise Works is developing and testing a treadle pump for use in wells where the water level is deeper than 7 m below ground level. It is reported to be able to lift up to 1 litre/second (3.6 m³/hr) from a depth of 15 m. It uses two pistons located 9 m below ground level but it does require two operators. A larger 150 mm diameter pump is also being tested, which produces a discharge of approximately 3 litres/second (11 m³/hr) but the suction lift needs to be less than 2 m. Beyond this it is reported to be very tiring to use.

Figure 10: ApproTEC super Money Maker (pressure delivery)

Pressure Irrigation Pump

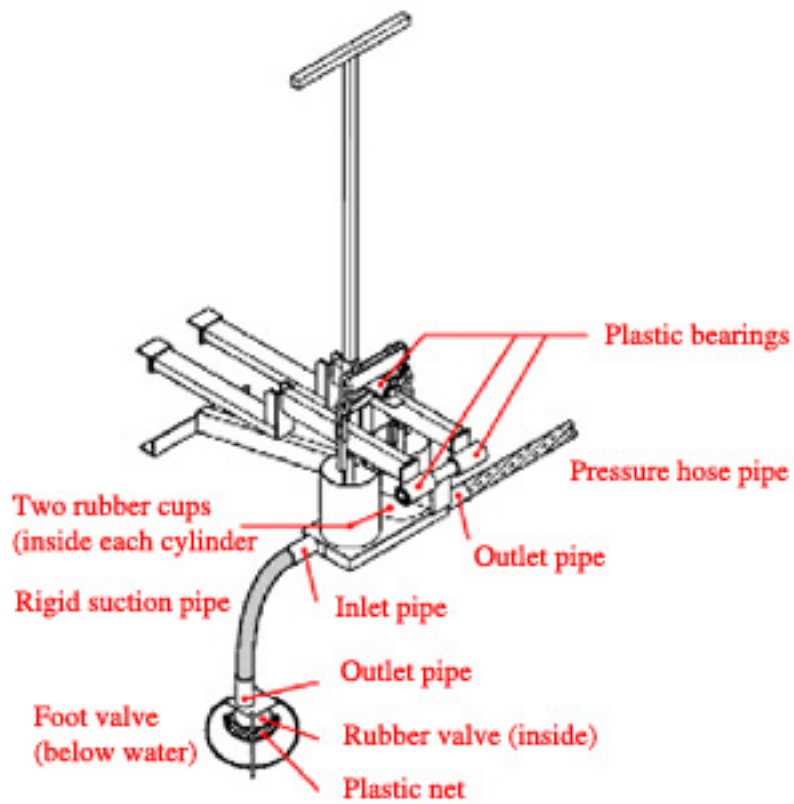

Figure 11: ApproTEC super Money Maker, Kenya

ApproTEC pumps – Kenya

ApproTEC, the Nairobi-based NGO, designs and manufactures its own suction and pressure treadle pumps (see The Kenya experience). These pumps operate on the same principle as the other pumps but there are several design features that are significantly different. ApproTEC says it has looked into the early designs of treadle pumps from an engineering point of view and have produced designs which it considers are more appropriate to the conditions prevailing in Kenya and other parts of Africa. This is particularly related to the need for larger suction lifts because of the lower watertables in Kenya and the need for pressurized delivery systems to overcome the rolling terrain on many farms. Portability is another issue, as pumps left in the field are in danger of being stolen.

One outcome of this redesign was a pump with an increased mechanical advantage – up to 4 – as compared to the other pumps, which range only between 0.8 and 1.2. The distance of the operator from the pivot point can be as much as four times the distance from the pivot to the pistons. This means that there is considerable leverage applied to the pistons, even by light operators. The result is that large pressures can be achieved, which is a desired output for both high suction lift pumps and pressure pumps. The increase in mechanical advantage means that the piston stroke length is shorter – 121 mm for the suction pump and only 73 mm for the pressure pump – compared with 250-300 mm for other pumps. This results in much less water being lifted per stroke. Both pumps have the same cylinder diameter, 121 mm, so the volumes per stroke are 1.32 litres and 0.8 litres respectively.

Another feature of the pumps is that they are of all-metal construction, including the treadles. Instead of a pulley wheel and rope system to connect the pistons, they use a chain and a rocker bar. Structurally, they are well engineered and robust but this does mean that spares are specialist items made under factory conditions.

Extensive tests of both suction and pressure pumps have been undertaken under controlled laboratory conditions; results are shown below in Figures 12 and 13. Figure 12 shows how the discharge varies with suction lift for both pump types. To try and overcome the operator problem, tests were undertaken with several different operators weighing around 65 kg. Each was asked to pump comfortably, i.e. at a pace that they could sustain for several hours. ApproTEC reports that it designs their pumps for a power input of 75 watts. This is similar to figures quoted earlier for the power that can be generated by a reasonably fit adult male but is much higher than the power inputs by farmers in Bangladesh.

The maximum discharge is similar for both pumps, reaching approximately 1.2 litres/second when the suction lift is less than 4 m. As the suction lift increases, discharge decreases rapidly because of the extra effort needed. There is an interesting and consistent dip in both curves between 2 and 5 m. As yet there is no physical explanation available for this. In terms of practical field operation, the dip is not significant.

The performance of the pressure pump seems to be slightly better than the suction pump, in spite of the fact that the valves are more rigid than in the suction pump to withstand the backpressure from

Figure 12: Performance of ApproTEC pumps for a 65 kg user

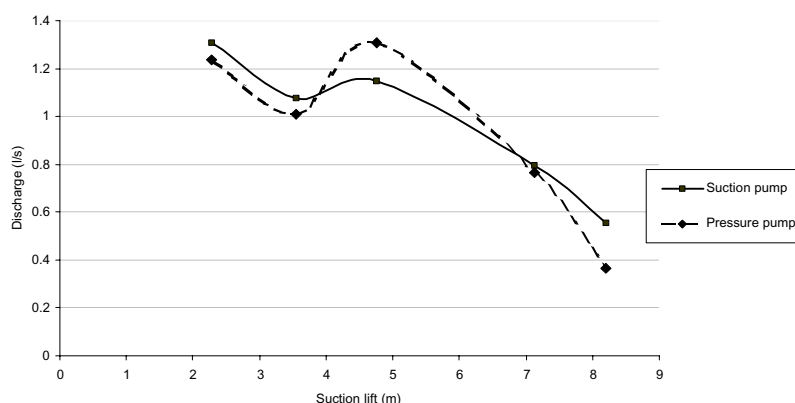

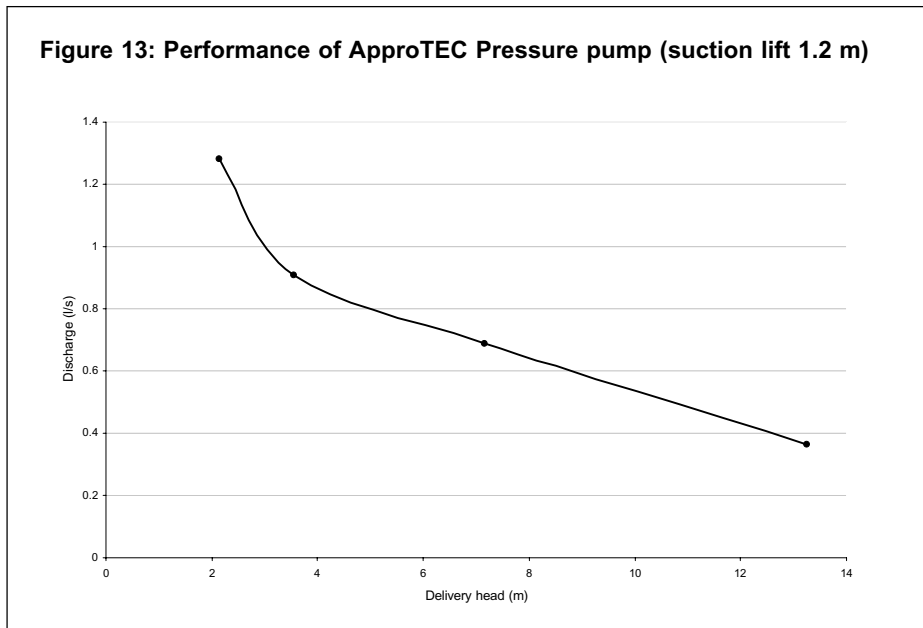

the delivery system, thus offering more resistance to the flow. This is a little surprising, but experience in Kenya suggests that operators do not notice much difference in the physical effort of operating the two pumps. Operators tend not to compare the effort needed to work the two pumps but rather compare the pump effort with the much harder and more strenuous method they used before to accomplish the same task. Another investigator reported that operators tend to put more effort (power) into using the pressure pumps to overcome any increase in resistance. The question then is whether they sustain the effort over the same time period (i.e. the energy input) as with the suction pump. No detailed studies have yet been carried out on this.

ApproTEC points out that their pressure pump performs a different role from the suction pump, so operators consider that any extra physical effort is negligible, given the additional range of pressures that the pressure pump offers. Most pump buyers, they say, decide to buy on the basis of price rather than on physical effort. Further data (Figure 13) show how the pressure pump performs against various delivery heads, based on a constant suction lift of 1.2 m. As expected, there is a direct relationship between discharge and pressure. As the delivery pressure requirement increases, the discharge available decreases. The pressure that can be achieved, up to 14 m delivery head, is significantly greater than any of the pumps reviewed so far. This is primarily because the increase in mechanical advantage. This high pumping pressure is a special

feature of ApproTEC pumps. Even when the suction lift is 6 m when pumping from a well, it is still capable of producing up to 8 m delivery head to overcome the problems of irrigating in hilly territory such as occurs in Kenya.

Any increase in suction lift beyond 1.2 m (Figure 13) would, of course, reduce the delivery head, because it is the total pumping pressure that matters and not just the delivery head.

Swiss “concrete” pump

This is a recent innovation developed by Swiss engineers and introduced into the United Republic of Tanzania in 1998. The engineers set out to produce a simple, robust suction pump that would not rust and that would be easy to construct. The result is a pump that comprises PVC cylinders surrounded by a block of concrete to give them support. The block also encloses the inlet manifold and the pivot supports for the treadles (Figure 14).

The cylinders are 110 mm in diameter, cut from standard PVC pipe. This material should considerably reduce the friction between the pistons and cylinders in comparison to the more traditional welded steel. The treadles are constructed from robust timbers and are positioned over a pivot point to give a high mechanical advantage. This exploits the same idea as the ApproTEC pump for developing extra force on the pistons.

As yet no performance data are available but outputs similar to the suction lift and discharge of the ApproTEC pump could be expected.



Figure 14: The Swiss “concrete” pump

COMPARING PERFORMANCE

Two pumps types are available and many modifications have been made to them. But which is the better one? At first sight this may seem to be a reasonable question to ask. In reality, however, it is a most difficult question to answer. First, the two main pump types are designed for different tasks, so they are not directly comparable. Second, there is not enough information available on all the design modifications to enable effective comparisons to be made. There are differences in design, e.g. materials used, dimensions of components and standards of workmanship. The methods of testing pumps are also different. A more appropriate question – and one that can be answered – is: Which is the better one for me? It is possible to set out some broad guidelines to help determine the most appropriate pump to use for a given set of site conditions.

In Africa, treadle pump design has been approached in two ways. One was to take an existing design such as the Bangladesh pump and modify it to suit African conditions. The second was to rethink the design and produce a pump that was better suited to African conditions. In most countries, the first approach was taken and the Bangladesh pump was used as the basic model on which to build modifications. This is essentially a suction pump and it was modified so that it could be used as a pressure pump. The second approach, taken by ApproTEC, was to develop new designs for suction and pressure pumps, based on African conditions such as deep watertables, hilly irrigated lands and the need for portability. Essentially, this approach exploits the

lever principle very effectively. A recent design by a Swiss organization has introduced a pump that exploits this same principle.

Pump performance data

Table 9 brings together the main physical features of the pumps so far described, particularly in terms of the water volume lifted per stroke and the discharge and heads that have been reported.

First, a general comment about the data available. They tend to dwell on the piston diameter and imply that this is related to head and discharge. It is related but it is only part of the picture. What is important is the volume of water lifted per stroke of the pump, which is the cylinder area multiplied by the stroke length. The speed at which the operator works determines how many strokes there are per second and this in turn determines the discharge. The force that an operator applies to the pistons and the area of the pistons determines the pumping pressure that can be achieved.

A comparison

The first and most obvious distinction to make is between the suction and pressure pumps. There are clear differences in the design and construction of the two pump types, because they are designed to do different jobs. Looking at each pump type in turn, a wide range of discharges and pressures is quoted, which can be confusing. The pumps looked at are all built around the same principle with similar materials, so one might expect to get broadly similar results, bearing in mind the limitations of human power input and the pressure and discharge that can be physically

Table 9. A comparison of pump data

Item	Piston diameter (mm)	Stroke length (mm)	Volume per stroke	Discharge (litres/sec)	Maximum suction head (m)	Maximum delivery head (m)	Maximum total head (m)
Bangladesh							
Suction	76–178	290	1.2–7	1–5	5	0	5
Zambia							
Suction	89	300	1.8	0.5–2.5	8	0	8
Pressure	100	300	2.25	0.5–2.5	6	7	13
Zimbabwe							
Pressure	100	290	2.2	0.5–2.0	8	0	8
The Niger							
Suction	100–150	250	2.3–4.2	0.5–3.0	6		-
Pressure	100	250	2.3–4.2		6	2	8
Kenya							
Suction	121	121	1.3	1.2	6.5	0	6.5
Pressure	121	73	0.8	1.2	6.5	14	14
Switzerland							
Suction	110	300	2.2	Not known	Not known	Not known	-

achieved. The conclusion to be drawn from this is that much of the variation must be a result of the methods of testing. Some of the tests were in the laboratory and some in the field. There is also the question of the operators: were they heavy or light? Was there one or were there two? How fast did they treadle? Unless there is a common basis for testing, a detailed comparison between pumps on a performance basis will need careful interpretation.

There are some broad conclusions that can be drawn for the information available.

Suction pumps

Suction pumps are designed for lifting large volumes of water from relatively shallow water sources. Pressure is not usually an issue. They are *low-head, high-volume-per-stroke* pumps. Pressure can be achieved either by using small diameter pistons with a long stroke length or larger diameter pistons with a relatively short stroke length. The Bangladesh pumps have relatively small diameter pistons and long stroke lengths to achieve high volumes. The diameter is largely determined by the ease with which an operator can push the pistons. The stroke length matches the natural step length of an operator, around 250–300 mm. Larger pistons usually require two operators working at the same time. A low mechanical advantage, 1 or 1.2, fits neatly with this arrangement.

The ApproTEC suction pump is quite different from the Bangladesh type. It has relatively large pistons of 121 mm and a short stroke length. This produces a much lower volume of water per stroke but it is designed with pressure in mind as well as

volume. Water sources tend to be deeper in Kenya than in other countries, so pressure, in this case suction lift, is a more important issue there than in Bangladesh, where the ground water is very shallow. To create the pressure, a greater force is needed on the pistons, which is achieved by exploiting a high mechanical advantage of up to 4. A large mechanical advantage and small piston stroke lengths go together, because of the practical limitations of the lever principle. Although the ApproTEC pump seems to produce a lower discharge value than other suction pumps, it is in fact designed for a different function. Bear in mind that this pump is designed for only one operator.

The pump is made from steel components, as are the treadles, which can thus stand up to the leverage forces that are applied. The wooden treadles commonly used in Bangladesh would not stand up to such forces. Far more robust timbers would be needed (see Swiss “concrete” pump).

As a general rule, when the water source is shallow (1–2 m deep) and large volumes are needed, the Bangladesh model is the most appropriate. When water sources are deeper than this, the ApproTEC pumps, with additional mechanical advantage, start to come into their own.

For shallow sources, average discharges based on sustainable pumping over the day for one operator would be in the range of 1–2 litres/second. This would increase if there were two operators working together. For the deeper sources, sustainable discharges of 1 litre/second or less would be more realistic.

Suction pumps are *low-head high-volume-per-stroke* pumps. As a general rule they are appropriate when the water source is shallow (1–2 m deep) and large volumes are needed. The Bangladesh model is the most appropriate. When water sources are deeper, the ApproTEC suction pump design, with additional mechanical advantage, starts to come into its own.

Pressure pumps

Pressure pumps are designed to create pressure, so the volume of water lifted is less important. They are used when there is a need to deliver water under pressure to sprinklers, drippers or a header tank. This requirement may be relevant to irrigating undulating or steeply sloping land.

High pumping pressures – remember, this is a combination of suction lift and delivery head – are created by using small piston diameters or increasing the force on the pistons. The latter can be done by using a heavier operator. Another way is to use a higher mechanical advantage, which in practical terms means shorter piston stroke length for the same leg stroke. Hence, pressure pumps tend to have smaller diameter cylinders with shorter stroke lengths, which means that a low volume of water is lifted per stroke. They can be described as *high-head, low-volume-per-stroke* pumps.

Most pressure pumps are based on the Bangladesh design, which was originally a suction pump. The modification comprises the addition of a delivery manifold, so that the water can be fed into a pipe and pressurized, rather than spilling over a lip into a canal. While the pump manifold has changed to accommodate this, the basic dimensions of small cylinder diameter and long piston stroke have remained the same, i.e. of the low-head, high-volume type. With piston diameters of 90–100 mm and an operator of 65 kgf, the maximum pressure that can be produced is only 8 m (see Discharge on p. 16). Allowing for only 70 percent of the operator's weight on the treadle, pressure would reduce to 6 m, which does not go far when some of it is taken up by suction lift. The only way to increase the pressure is to use a much heavier operator – or two operators – or increase the mechanical advantage. Using a typical advantage of 1.2 would only increase the pressure to 8 m.

The ApproTEC pumps exploit mechanical advantage to produce pressure with only one operator. A mechanical advantage of 4 with a 120 mm diameter piston and an operator of 65 kgf could produce a maximum pressure of 24 m. Allowing for only 50 percent of the operator's weight on the treadle reduces the pressure to a more practical 12 m.

As a general rule, when water sources are deep – more than 4 m – and/or a pressurized supply is required, the ApproTEC pressure pump, with its high mechanical advantage, is more appropriate. This is not to say that the Bangladesh model will not do a useful job; it is just a less appropriate design from a performance point of view and unless a very small piston is used it will not achieve high pressures.

Pressure pumps are *high-head low-volume-per-stroke* pumps. As a general rule they are appropriate when water sources are deep (more than 4 m) and/or a pressurized supply is required. The ApproTEC pressure pump, which exploits a high mechanical advantage, is more appropriate in this situation. The Bangladesh model will still do a good job but it is less appropriate from a performance point of view.

One last point about pressure pumps. There is often discussion about whether suction lift and delivery pressure are separate issues or are related to each other. They are very much related and any change in one will directly affect the other (see Total pumping head on p. 12). In other words, when pushing down on one piston to create pressure, the operator is also pulling up on the other piston to create suction. The deeper the suction, the greater will be the effort to lift the piston, which will have a direct effect on the operator's ability to push down the other piston and create delivery pressure.

Pumping speed – effects on head and flow

If a human being could produce a steady power output like a machine, a pump operator would simply adjust the speed of working to take account of different pump sizes, heads and discharges. People do not behave in this way, of course. They have a fairly limited range of operating rates and are often most comfortable at fairly slow and steady speeds, though some operators do prefer short, rapid stroke movements. This makes it difficult to compare pump performance, as so much depends on the operators in terms of their weight and the speed at which they like to work.

It is sometimes argued that when the pressure requirement is low, i.e. low suction lift, it should be possible to treadle a pressure pump at a faster rate and achieve high volume, just like the suction pump. In practice this does not happen, as most people have a limited range of pumping speed and are most comfortable at slow steady speeds. What happens is that an operator working on a pressure pump – a high-head, low-volume-per-stroke pump – would work at fairly low speed even at low suction lifts and

get low flows, whereas the same operator would treadle a suction pump – a low-head, high-volume-per-stroke pump – at the same speed and suction conditions and get a substantially larger flow.

Pressure pumps have other inherent losses when used in low suction lift conditions. As an operator treadles faster to get a greater discharge, there is a greater percentage of time when both inlet and outlet valves are open at the top and bottom of the strokes. Valves that open and close slowly thus become a much bigger constraint than for a suction pump, which can be operated at much slower speeds for the same output. Additionally, pressure pumps have more valves, with consequent higher energy losses.

As a general rule, operators like to pump at a slow steady speed, irrespective of the pump they are using or the head and discharge conditions on site. This emphasizes the importance of the operator when assessing pump performance.

The Zambia experience

This chapter is based on a report prepared by Angel Daka, IDE Zambia.

BACKGROUND

Zambia has faced food deficits for more than a decade, primarily as a result of recurrent droughts, which have affected rain-fed farming and the small-scale farmers who depend on this type of farming. There are about one million small-scale farmers in Zambia, who contribute about 80 percent of the total food production in the country. Zambia's population is growing at an annual rate of 3.2 percent. This has put pressure on the country's food resources, which currently cannot meet the increase in demand. Unless prompt strategic measures are taken to increase production rapidly, food aid or commercial food imports on a large scale will be inevitable.

In view of the need to stabilize year-to-year food production, FAO initiated a Special Programme for Food Security in low income food deficit countries (LIFDCs). Zambia was among the first of about 80 eligible countries to confirm its participation in this programme. It commenced in December 1996 and has been primarily aimed at disseminating existing proven and appropriate agricultural technologies to support increased food production.

A major component of the programme has been promotion of improved water use by introducing individual farmers to treadle pumps, which are regarded as an affordable and manageable alternative to the laborious method of watering by hand-carried buckets filled from streams and springs near to irrigated fields. Technically, this form of pumping is well suited to Zambia, where small-scale farmers use surface water such as rivers and low-lying swamps or shallow groundwater, in particular dambos.

In 1996, FAO commissioned IDE, with its considerable experience of treadle pumps in Bangladesh and India, to examine the manufacturing potential and use of these pumps. Treadle pumps had proved very successful among small marginal farmers in Asian countries, so transfer of the IDE treadle pump technology was considered for Zambia. Potential manufacturers were identified and a pilot programme started in 1996.

IDE trained potential pump manufacturers and those who would be responsible for their installation. They supplied the first 20 pumps, of which ten were installed as part of the training programme. The interest from farmers during this period of demonstration was considerable and there were many requests for similar demonstrations in other areas. The SPFS then ordered 150 pumps for use on more demonstration sites.

In July 1997, IDE established an office in Zambia as a non-profit NGO with the principal aim of developing a marketing and promotional network for treadle pumps. Its plan was to work with the Government and FAO to develop small-scale irrigation among marginal farmers, particularly in the pilot areas but also extending to other parts of the country. IDE now has offices in four provinces – Lusaka, Eastern, Southern and Central – to support this initiative. Interestingly, the use of treadle pumps has spread into the remaining five provinces, with over 700 units sold on a commercial basis.

PILOTING

In December 1996, the SPFS, in conjunction with the National Irrigation Research Station, requested Kasisi Agricultural Training Centre (KATC) to manufacture 16 plastic pressure pumps for testing at selected pilot sites in Southern, Central and Lusaka provinces. They had already been manufacturing and selling plastic pressure pumps to local farmers and graduate youths from the training centre. Because of the lack of extension and promotional activities, only ten pumps had been sold in the previous five years.

The outcome of this pilot study was not good. The plastic pressure pump, held by a wooden superstructure, was poorly constructed and the bolts holding the pump on to the superstructure fell apart within a few weeks of use in the field. The plastic became brittle when left in the sun and damage occurred through mishandling, particularly during movements from field to homestead for storage away from thieves. Also, the extension staff were ill-prepared to appreciate their practical use. Where they were successfully installed, discharges up to 2.5 litres/second were recorded, although at the time it was

generally considered that they were more suited to domestic water supply than to irrigation.

IDE strengthened the pilot programme by ordering 350 treadle pumps from IDE Bangladesh. A further 150 pumps were also ordered from a local manufacturer, Knight Engineering (Zambia). During this time, IDE established an office in Zambia and it was decided that in order to have a sustainable programme, the pumps would be handed over to IDE for marketing on a cash-and-carry basis. IDE would use the cash generated to purchase further pumps from local manufacturers who had been trained by IDE. They were supported in the marketing and promotion by the Ministry of Agriculture Food and Fisheries (MAFF) and NGOs whose programmes would benefit from the use of treadle pumps.

AVAILABLE PUMPS

Four types of treadle pump are currently being manufactured:

- tube well pumps
- modified pumps
- river pumps
- pressure pumps

The tube well, modified and river pumps are all suction pumps that have been modified to suit the site conditions around the water source. They all have twin 89 mm cylinders and a spout on the delivery side so that water spills over the pistons into an irrigation channel. The principal differences occur in the superstructure. The original tube well pump was difficult to work over a well, so the modified pump was made with anchoring bars to fasten it to the top of the well casing. This model has now become the most popular and the original tube well pumps are now rarely sold. The modified pump also has a 50 mm pipe welded on to the spout to make it suitable for use with a pipe on the discharge side.

The pressure pump is essentially the same as the Bielenberg model (Enterprise Works pumps – the Niger). It has twin 100 mm diameter cylinders and uses leather cups fixed to the pistons for sealing.

Details of their performance are given in the section on IDE pumps – Zambia.

MANUFACTURE

Capacity

There is manufacturing capacity in Zambia involving large-, medium- and small-scale enterprises. This is primarily due to the mining industry in the country,

which has resulted in trained artisans setting up their own private workshops. Several small workshops have expressed interest in manufacturing treadle pumps. There is, however, the possibility of pirated designs coming on to the market from manufacturers who have not been screened for the quality of their product.

The first manufacturer to be trained in the production of high-quality treadle pumps was Knight Engineering, a large company based in Lusaka. The following year, in May 1998, two more companies, SAMS cooperatives and SARO Engineering, were trained to produce pumps, bringing the number of manufacturers to three. As the market for treadle pumps has grown, so has demand from other small-scale enterprises to be trained in pump production. As a result, a further five manufacturers have been trained by IDE: Katopola Agricultural Engineering Services (KAESE), DEN-MWA Engineering, MILO Investments, Chokwadi Appropriate Technology Services (CATS) and KATC.

At present, manufacturers only supply the basic pump head, which comprises the cylinders, pistons and inlet and outlet arrangements. This is supplied to IDE, who then fit the non-return valves, piston seals, treadles, pulley and rope prior to distribution. It is possible for manufacturers to buy these components from IDE or from other suppliers. However, the non-return valves and the piston seals are a specialist item imported from Bangladesh and are currently only available from IDE.

Materials and tools

Pump manufacture is essentially a metal fabrication process involving the cutting and welding of metal sheets and pipes. All the trained manufacturers are producing similar pumps using similar materials and designs specified by IDE. The pumps are not difficult to manufacture once the workshops are set up and staff have been trained properly. It is manufacturing precision that ensures pumps are durable and perform reliably and well in the field. For this reason, quality control has become one of the most important activities in the manufacturing process.

Tools needed

Basic tools and equipment required to make the pumps include:

- welding equipment
- manual or hydraulic cutting machines and/or guillotine
- angle cutter

- lathe (optional)
- rolling machine
- junction block mould
- drilling machine
- dies
- 88 mm mandrel
- grinding machine

In addition to the above equipment, the following tools are required:

- hacksaw frame and blades
- rubber perforators
- big and small files
- welding electrodes
- pliers
- scissors
- large and small hammers
- steel measuring tape
- square
- metal scribers

Materials

The twin cylinders are manufactured from sheet steel rolled into cylinders with a manual roller. They are spot welded and smoothed with an 88 mm diameter mandrel to avoid damage to the rubber cups caused by the welded spots. It is usually necessary to file out such spots.

The suction pumps use rubber cups on the pistons and plastic non-return valves in the base of the cylinders. These are specialist items made by injection moulding. At present, they are imported from IDE Bangladesh and made available to retail outlets. The pressure pumps use leather seals for the pistons and rubber seals cut from old tyres for the non-return valves. These can be obtained locally.

Treadles are made from mukwa wood, which makes them stronger than those made from pine.

Quality control and warranty

IDE has set up quality-control procedures with all the manufacturers; IDE staff currently undertake the inspections. Pumps are inspected during the manufacturing process and are tested for any defects before being transported to their provincial destinations. Inspection ensures there are no leaks or rough spots in the cylinder bores and that the internal diameter of the cylinders conforms to the design specifications. Checks on the superstructure are made to ensure that the pump, pulley and treadles are well aligned in relation to the pistons entering the cylinders.

All faulty pumps are rejected and good ones are certified for use in the field.

A 12-month guarantee is given to any customer who buys a quality-controlled pump. Each manufacturer paints their pumps a specific colour so that manufacturers can be easily identified. In addition, punched plates with identification numbers are riveted to each pump.

Marketing officers and retailers are taught to identify quality pumps in the field. It is the duty of manufacturers to ensure that high-quality pumps are produced, as frequent breakdowns in the field would erode consumer confidence in the technology. The guarantee does not cover vandalism or damage caused by carelessness.

When a pump is found to have a leak or has not been made to specification, it is returned to the manufacturer with instructions to rectify the fault. Data collected by IDE on product defects and breakdowns in 1998 are shown in Table 10.

Table 10. Problems with defects and breakdowns

Problem	No. of pumps	% of total sales
Defective during manufacture	23	3.5
Product breakdown within one year	1	0.14
Faulty installation	2	0.28
Warranty invoked	0	0
Product abandoned by user	0	0

Source: IDE Zambia

OPERATION, MAINTENANCE AND REPAIR

The pressure pump pistons have leather seals which must be wetted prior to use, otherwise they will not provide a good seal and the pump will be difficult to prime. It is reported that the pump is very hard to operate, due to the tight fit of the leather seals; two operators are often needed at the same time for pumping.

Treadle pumps are easily maintained and repaired by the average user. The pump head can last up to seven years, the rubber cups between 3 and 24 months, depending on how they are used. Non-return valves can last as long as the pump. The only movable part on it – the rubber flap – may be replaced as necessary. It can be made at village level using a cut-out from a bicycle or motor-vehicle tyre inner tube.

Rubber cups wear out easily if used to pump dirty and muddy/sandy water. Use of a strainer made of mosquito wire mesh is recommended at the intake. The rubber cups and foot valves should be thoroughly

cleaned in water after use. Storage of the pump should be in shade in a safe place where thieves cannot steal it.

Experience shows that the nylon pulley rope often breaks but this is the easiest part to replace at village level. Farmers often use cattle hide to make a strap as a replacement. When treadles or the pulley break, farmers can find wood from the bush and replace the treadles easily by following the design length and slots from the old one.

DISTRIBUTION NETWORKS

A distribution network consisting of manufacturers, wholesalers, retailers, NGOs, private partners and customers (farmers) has been established. In addition to the eight manufacturers, there are now 28 retailers and 30 active collaborating partners, including government departments, that deal in the distribution and sale of treadle pumps. This development and replication of a marketing chain is referred to by IDE as rural mass-marketing.

There are two ways in which the supply-chain functions. The first involves the supply of pumps from the manufacturer to the retailer, with IDE acting as a distributor. The second is a more conventional chain, with retailers buying pumps directly from the manufacturer.

IDE decided to undertake the distribution role, because many retailers do not have the capital or the access to credit to work directly with manufacturers. Agreements were established with the three main manufacturers allowing for the provision of pumps on a consignment basis to IDE for sale at their offices and through registered retailers in the four provinces who have signed agreements with IDE. The retailers only pay IDE for the pumps when they are sold to farmers, for which they receive a commission incentive. The money is then paid back to the manufacturers for continued production. IDE do occasionally have to absorb losses when an agent fails to pay up. In spite of this, the arrangement is reported to be working well and the three manufacturers have been producing high-quality pumps at a reliable rate.

The retailers who have been recruited were selected because of their strategic positions in major provincial towns. Interviews were conducted with the shop owners to determine their level of commitment to the programme, the strength and reputation of their business and their accountability and willingness to accept the low price mark-ups which were being recommended. Agreements were made with each

retailer to adhere to the pricing structure and to report on all sales at the end of each month. In return, retailers received pumps on a consignment basis, together with promotional literature and manuals for operation and maintenance. They were also trained in the working of the pumps and methods of promotion.

A group of sales agents has also been recruited, who promote the pumps directly to farmers and receive payment on a commission basis. They work in strategic locations in Lusaka and the provincial towns, setting up demonstrations and distributing literature in public areas such as markets. People are encouraged to ask questions and to try the pump for themselves. The response has been very enthusiastic in every part of the country.

The IDE input, although important in establishing the treadle pump supply chain, is only a temporary measure. Retailers are gradually being encouraged to go direct to manufacturers, so that they can order pumps using their own resources and make a profit when they sell them on to the farmers. The role of IDE as a distributor is expected to cease between the third and fifth year, when it is anticipated that a sustainable chain of supply and demand will have been created. IDE will then concentrate on promotions and marketing.

MARKETING AND PROMOTIONAL ACTIVITIES

Treadle pumps have been promoted principally through practical demonstrations in farmers' fields and at IDE offices in Eastern, Lusaka, Central and Southern provinces. Demonstration gardens have been established in strategic areas where rapid adoption could be expected. In these gardens, a treadle pump is installed and operated by the community to irrigate vegetables. Farmers have the opportunity try out the pump in their own time. Demonstrations have also been organized on field days and at agricultural shows. At these events, pamphlets, leaflets and brochures providing information about the pumps are distributed to clients. Table 11 provides some indication of the level of these activities.

Table 11. An indication of promotional activities

Type of activity	No.
Village demonstrations	146
Field days	75
Agricultural shows	9
Public group demonstrations	120

Other marketing strategies include advertising retail outlets and the pumps through radio programmes, television and newspapers. It is planned to commence printing of calendars and T-shirts that show treadle pumps in use and give details of the benefits. Village theatre performances too have had a very favourable impact on sales.

Many partner organizations have been recruited to participate in promotion. NGOs such as CARE International, Africare, the US Peace Corps and others have not only promoted the use of treadle pumps but have also purchased pumps for use in their own programmes.

Some examples:

- Zambia Coffee Board has purchased three pumps for irrigating smallholder coffee plantations and has requested follow-up to consider further investment.
- Agriflora is considering collaboration with IDE to organize groups of farmers to form out-grower schemes to promote cultivation of horticultural crops for export to Europe and the United States.
- Rotary International has requested treadle pump training to introduce the technology among the village Rotary Volunteer Groups throughout Zambia.
- CLUSA is incorporating treadle pumps into its small business credit scheme.

UPTAKE OF PUMPS

Results of the promotional activities, pricing and training are shown in the sale of pumps in Figure 15. This indicates a steadily increasing number being sold, with a total in excess of 1 400. Almost half the sales are for river pumps; the rest account for about 200 pumps each.

COSTS AND PRICES

Pump prices vary at present, depending on the type of pump being purchased and the way it is supplied to the farmers. The latter is a temporary issue and

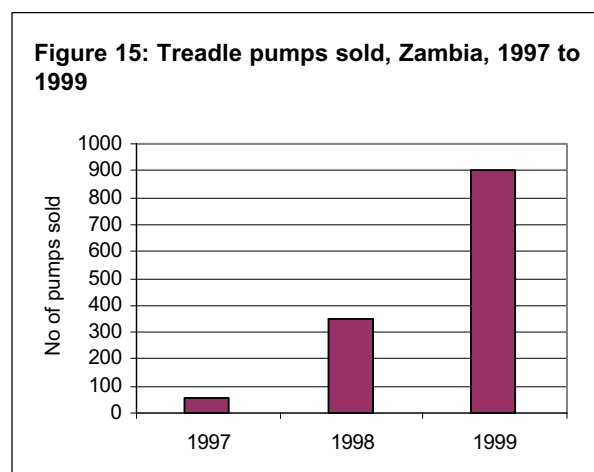

relates to the two supply chains currently operating (see Operation, maintenance and repair). Retailers who deal directly with manufacturers take a financial risk in purchasing pumps for sale, so they are rewarded with a profit mark-up when they sell a pump on to a farmer. Many retailers do not have such access to funding, so the alternative is to take pumps from IDE, who carry the financial burden. When a pump is sold to a farmer, the retailer receives a commission from IDE for the sale.

Table 12 shows how IDE arrived at their selling price for the different pumps. It can be seen that these prices are higher than those charged by retailers who source their pumps directly from the manufacturers and finance them independently.

To encourage the uptake of treadle pumps, IDE currently subsidizes the pumps supplied by them by approximately 3 percent on the river and modified pumps and 9 percent on pressure pumps, which brings their prices more into line with those of the independent retailers.

Even with the subsidy in place, however, independent retailers are still able to price their pumps lower than those supplied by IDE and still make greater profits. This is because they have identified small, local manufacturers, who have lower overhead costs than some of the larger organizations who supply IDE. Retailers also look to cheaper local carpentry workshops, where treadles cost much less.

Table 12. IDE pricing structure for treadle pumps (US\$)

Components	River pump	Modified pump	Pressure pump	Tube well pump
Pump head cost	50	50	83	38
Commission	8	8	8	8
IDE selling price	75	77.3	121	60.4
IDE subsidized price	73	73	110	60.4
Retailers selling price*	71	71	100	-

*Retailers selling price when pumps are sourced directly from the manufacturers.

The proximity of retail shops to small manufacturers reduces transport costs as well.

When the subsidy is eventually removed, which is expected between the third and fifth year of the programme, retailers and farmers will have to buy and sell at the market price prevailing at that time. They will also have to finance the pumps using the more conventional supply chain.

IDE's future role is not to continue to sell or distribute pumps but to promote the businesses of retailers and manufacturers through continued demonstrations and marketing activities, including capacity building. It is anticipated that a more conventional commercial supply chain will be established. The incentive for this is the mark-up for the retailers.

Over the past two years, pressure has been brought to bear to keep the price of treadle pumps down, in spite of a currency devaluation of 55 percent during the first year of sales, which pushed up the local price of imported steel. This was achieved through promotional activities, which stimulated an increase in demand, which in turn provided the leverage to negotiate lower manufacturing prices and healthy competition among the pump producers.

TRAINING

Training has been undertaken at three levels:

- *Government extension staff who work directly with irrigation farmers.* The training was designed to build up capacity in irrigation in the extension service. It included horticultural methods, irrigation techniques, water management including crop water requirements and scheduling, treadle pump operation and maintenance. Stripping and assembling a pump highlighted its technical aspects and the importance of proper installation procedures. Correct maintenance of each individual component of the pump was emphasized. A field demonstration was conducted where farmers were growing vegetables.
- *Retailers involved in purchasing pumps and selling them on to farmers.* This has involved marketing and promotion of treadle pumps, customer relations, after-sales services, quality control and identification of a quality pump, record keeping, business development and accounting records. Twenty retailers have been trained and now feel confident of running their businesses more effectively.

- *Farmers using the pumps for irrigation.* User training has been conducted by the MAFF Technical Services Branch under the SIWUP project funded by FAO and the International Fund for Agricultural Development (IFAD) and by IDE. MAFF has primarily trained technical staff at provincial and district levels in the fifteen pilot areas; this has now expanded to include other provinces. Technical staff in turn train camp and block extension officers who, together with the technical staff, train farmers in the use of the treadle pump and in water management and agronomic practices.

SOCIAL AND CULTURAL IMPACT

Women play an important role in agriculture in Zambia. Jobs such as irrigation, weeding, fertilizing and harvesting of vegetables are generally considered to be women's activities. Women operate treadle pumps without any traditional or religious restrictions, as is the case in Asian countries, where women do not wish to be seen working treadle pumps. Early scepticism that women who use treadle pumps excessively would not conceive because the movements during operation affect the womb have largely been dispelled.

MAFF is concerned that the introduction of treadle pumps should empower women. IDE believe that the pump is well suited for women to use and have made a conscious effort to ensure that women are targeted. For example, they use women in their publicity material. However, it has been reported that women find the pumps harder to operate than men and young boys, who were easily able to work the pumps and showed considerable enthusiasm (Chancellor and O'Neill, 1999). Women do find the suction pump easier to use than the pressure pump.

Although women are the main users of treadle pumps in Zambia, of all the pumps sold in 1999, only four were purchased by women (Chancellor and O'Neill, 1999).

Some indication of the socio-economic impact of treadle pumps can be obtained from this typical day in the life of a Zambian farming family.

Mr and Mrs Sichonti have a vegetable garden where they grow rape and tomatoes for their own consumption and for sale. Last season Mr Sichonti planted paprika in their garden, which increased Mrs Sichonti's workload, as the task of watering is

Table 13. Wife

Without treadle pump		With treadle pump	
05.00	Wake up to go to work in the main fields	05.00	Wake up to go to work in the main fields
12.00	Return home to prepare lunch, clean dishes and pots, draw water	12.00	Return home to prepare lunch, clean dishes and pots, draw water
14.00	Go to garden, water vegetables using cans	14.00	Go to gardens, prepare beds for paprika, transplant paprika. Return to main fields to harvest groundnuts
16.00	Move to the main fields to harvest groundnuts and other crops	17.00	Return home, draw water and clean dishes and prepare dinner
18.00	Return home to prepare dinner, draw water and clean dishes and pots		

Table 14. Husband

Without treadle pump		With treadle pump	
07.00	Wake up, go and plough and plant main fields	08.00	Join wife at the main field or herd cattle
11.00	Drive animals to the watering-point	12.00	Have lunch, go to the main garden to make beds, fence garden
12.00	Have lunch	14.00	Prepare nursery to plant seeds. Water using treadle pump
14.00	Go to check progress of work on garden. Instruct wife what to do	17.00	Go home to wait for dinner
15.00	Go home and rest or do some maintenance work		

primarily the role of the wife and other females in the household.

Mrs Sichonti was loaned a treadle pump to assist her with the additional irrigation. This changed their daily routine as indicated in Tables 13 and 14.

The benefits of using the treadle pump included:

- reduced labour demand: Mr Sichonti has now started to irrigate the vegetables, a task previously done by his wife;
- reduced irrigation frequency: with buckets, irrigation was needed every two days; with the treadle pump, irrigation was needed only every five days; more water is applied using the treadle pump, so less frequent irrigation is needed;
- reduced workload: lifting shallow groundwater with buckets is far more strenuous than with a treadle pump; Mrs Sichonti spent seven hours each week lifting water with buckets, whereas her husband now does the job in four hours.

Some farmers are slowly changing their cultural calendars of resting and attending to traditional ceremonies in the dry season, as they have to grow crops throughout the year.

Irrigated crops have proved to be more profitable than rain-fed farming, so some farmers are beginning to abandon rain-fed maize in preference to horticultural crops.

Because treadle pumps reduce the time taken for irrigation, some farmers now hire out their pumps,

though to a limited extent, as they fear breakdowns caused by carelessness. This is why group ownership of the pump is socially unacceptable. Individual ownership is mostly preferred.

Some farmers who are using treadles successfully are now acting as agents for promotion, which has resulted in increased adoption.

ECONOMIC IMPACT

It is estimated that over 6 000 families have now had direct exposure to the new treadle pump technology through various public demonstrations. At the end of 1998, approximately two years after the start of the programme, some 650 families have installed pumps. Assuming an average family unit of six members, the number of direct beneficiaries comes to 3 900. Data are not yet available for 1999 but it is anticipated that this number will have increased substantially.

Interviews with farmers who have been using the pumps since 1996 suggest that household incomes have risen substantially and employment has increased as a result of the enlarged gardens now being irrigated.

Interviews with treadle pump users in four provinces indicate that incomes have risen from US\$125, achieved with bucket irrigation on 0.25 ha of land, to US\$850-1 700 using treadle pumps. This was attributed to the ability to irrigate a larger area,

as well as improved crop yield and quality. Cropping intensity also rose, in some cases up to 300 percent. There was also a noticeable increase in the variety of crops grown. Because of the increase in water availability, farmers were more willing to take risks with new crops. A typical small farm would normally grow two or three different crops but treadle pump users now grow five to nine different crops. This enabled farmers to provide food for the family all year round by generating cash income as well as growing crops for home consumption.

In addition to the direct benefits for farming families, there is a positive effect on the whole supply chain of manufacturers, retailers and selling agents. Employment has increased in rural areas, where artisans are manufacturing pumps, carpenters are producing treadles and an increased work force is needed on the farm to cope with the additional produce.

Reported benefits include:

- between 60-75 percent reduction in labour in an eight-hour working day;
- gardens expanded from 0.1-0.25 ha as a result of time saving on irrigation;
- cropping patterns diversified to include high value vegetables such as peas, tomatoes, rape, cabbage, Irish potatoes, fresh corn and pumpkins;
- income from irrigated crops used to purchase inputs for upland crops;
- irrigation used for seed multiplication; examples include seed maize, cassava cuttings and sweet potato vines;
- positive impact on fertilizer use, which can be more easily matched with expected soil moisture;
- crops unaffected by surface irrigation from treadle pumps after spraying, as happens with bucket irrigation.

The increase in crop yields can bring with it the problem of a market glut when supply exceeds demand. This is a particular problem with common household crops such as tomatoes, rape and onions and it is exacerbated by the tendency of farmers to grow the same crops at the same time of year. The search for new, more distant markets may solve this difficulty but it can create other problems. Rural transport is not only expensive but it is difficult to find in remote areas that have poorly developed feeder roads. It is also unreliable. A farmer may have to wait days for transport, which may result in deterioration of perishable produce and this in turn reduces profits.

IDE, in collaboration with FAO and MAFF, is actively looking at ways of avoiding the glut problem. These include encouraging farmers to:

- adopt alternative cropping patterns and harvest crops at times of anticipated shortage caused by climatic and agronomic factors;
- take up contract farming, whereby a prospective buyer agrees in advance of planting to purchase crops such as chillies, strawberries, beetroot and cauliflower – crops in demand by Indian businessmen and also exported to Malawi;
- link with bulk buying companies who supply retail shops and supermarkets;
- organize market days on a regular basis;
- introduce solar drying and food processing technologies for processing and preserving surplus produce;
- adopt alternative low cost transport systems, such as bicycle-powered carts.