

9 GENERATING ELECTRICITY

- 9.1 Safety Warning
- 9.2 Electrical Standards
- 9.3 Earth-fault protection
- 9.4 Generator Options
- 9.5 Using 3-Phase Induction Motors as Single-Phase Generators.
- 9.6 Electronic Load Control
- 9.7 Alternatives to load control
- 9.8 Selection and Sizing of Generator, Capacitors, Cable and Protection Equipment
- 9.9 Installation and Connection

9.1 Safety Warning

Electricity can be extremely dangerous. If a person comes into contact with a live wire or faulty equipment with a voltage higher than 50V, it is possible for them to receive a fatal electric shock. The electricity generating system described here is designed to operate at mains voltage (120V or 220V AC depending on the national standards). Anyone carrying out electrical installation work at these voltages must be supervised by a qualified and experienced electrician. In addition the following safety instructions must be strictly followed:

- Before attempting any installation or maintenance, ensure that the generator is not turning and that the flow control valve on the penstock is firmly closed. Hang a label on the valve to warn others if maintenance is done outside the powerhouse (e.g. "Maintenance in progress - do not operate!").
- Earth all metal cased equipment with a suitable earth connection (see 9.3)
- Never touch any electrical equipment with wet hands.
- Install all equipment according to manufacturer's instructions.
- Do not adjust or attempt to repair equipment unless trained to do so.
- Notices that warn of the danger of high voltages should be clearly positioned on the door of the powerhouse, on the case of the controller and on the front of each load limiter.

9.2 Electrical Standards

National electrical standards should be followed. In some countries, special standards for micro hydro and/or isolated village electrification have been agreed. These standards should be followed even if they disagree with the recommendations given here. Please read the disclaimer at the front of this manual.

9.3 Earth-fault protection

An earth fault occurs, for example, if a live wire becomes loose inside a device and touches its metal case. An **RCD** (Residual Current Device) will disconnect the supply if a fault like this causes a large enough current to flow to the ground (i.e. if the case is earthed or someone touches the case and makes a path to earth). It can also disconnect the supply if someone accidentally touches a live wire causing current to be conducted through them to the ground. This reduces the risk of fatal electric shocks though these can still occur if someone touches both line and neutral and is insulated from the earth. The RCD required is one with a residual tripping current of 30mA. It should be connected directly to the generator as shown in Figure 9-7.



Figure 9-1 3-phase RCD

In addition to an RCD, **earth electrodes** are required to allow the RCD to function. These are metal conductors that are in close contact with the soil and provide a low resistance path for the current to the ground. Connection to an earth electrode is required near the generator. Earth electrodes are also required if any of the electrical loads have metal cases (electric cookers, for example). The resistance of the

earth should not be greater than $1k\Omega$ if an RCD with a 30mA tripping current is used. Measurement should be carried out with an earth tester. The manufacturer's instructions should be carefully followed to ensure accurate results. Earth testers are expensive (typically \$600 to \$1000). Consider hiring or borrowing unless you do a large number of schemes.

Three methods of installing an earth electrode are described:

Method 1 The easiest electrode to install is usually a 1 metre copper-coated steel rod that is driven into the ground near to the powerhouse. The electrode is connected to the neutral terminal at the generator using a low-resistance heavy-gauge copper cable (e.g. SWG 10mm²) and a brass, connecting nut that slides over the rod and allows the cable to be clamped in place. Two shorter rods can be used and connected together if it is not possible to drive the rod 1 metre into the ground. They should be spaced at least two metres apart and connected with the same earth cable.

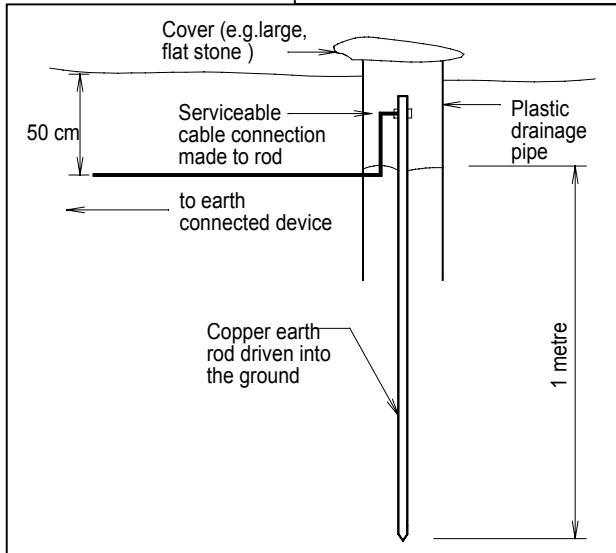

Figure 9-2 A 1m copper-coated steel rod can provide a suitable earth electrode.

Method 2 A second method is to use a loose coil made of about 10 metres of SWG 10 bare copper wire. This should be spread out and buried in a hole about one metre deep. If the soil is damp where the powerhouse is constructed, then the

coil of wire can be buried underneath the foundations. Do not bury under the foundations if the soil type is very dry as the resistance is unlikely to be low enough.

Method 3 A third method is to use a copper plate measuring at least 500mm x 500mm. This should be buried in a hole at least one metre deep in an area which remains moist.



Figure 9-3 Installation of a copper-plate earth electrode, Multiple earth cables have been soldered in place to reduce the resistance and increase the reliability. (Nepal)

9.4 Generator Options



Figure 9-4 3-Phase Induction Motor (7.5 kW) with double-ended shaft, used as a generator. (Nepal)

Induction generators and synchronous generators produce AC power. Alternating current (AC) and direct current (DC) are explained in the Appendix. The main advantage of AC is that the power can be transmitted over quite long distances. This makes AC suitable for village electrification projects because the electrical loads (such as light bulbs) are usually quite spread out and often a long way from the generator.

Induction generators are good for providing electricity in remote areas because they are

robust and very reliable. However, they are not the only generators that are used for hydro power projects. Different generators have been compared in Table 9-1. Situations where it may be more practical to consider other generators in addition to the induction generator include the following:

1. Very low cost power systems for battery charging or lighting only in a single dwelling next to the powerhouse. Consider a DC generator.
2. Schemes required to power motor loads greater than 15% of the generator rating are best supplied by synchronous generators. For more information about motor starting using induction generators, read Section 13.

9.5 Using 3-Phase Induction Motors as Single-Phase Generators.

Purpose built induction generators are expensive but three-phase induction motors can be used as generators when run in reverse. These are mass-produced and so are quite cheap and easily available. For most small electrification projects, a single-phase supply is required. It is quite easy to produce a single-phase supply from a three-phase motor. This is done by connecting unequal amounts of excitation capacitance across the winding of the machine as shown in Figure 9-6. This is called C-2C because across the second generator phase, twice the amount of capacitance is connected. On the third phase no capacitors are connected.

It is important that capacitors of the correct type are chosen and properly connected otherwise the generator could fail to operate or overheat. The manufacturer who supplies the turbine and generator should also supply capacitors of the correct size. If the individual components are bought separately, then follow the advice given in Section 9.8.



Figure 9-5 Power Capacitors suitable for connection to induction generators

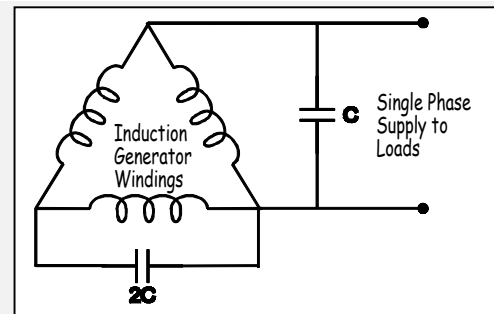

Figure 9-6 Single-phase supply from 3-phase motor

| Type of Generator | Source | Typical Cost for 3kW Machine | Speed (rpm) Options | Disadvantages | Advantages |
|-------------------------|---|--------------------------------------|--------------------------|---|---|
| Induction | Standard industrial motor used as a generator | Low: \$200 - \$250 | 1000, 1500, 3000 | Needs correctly sized capacitors connected to operate as a generator. Poor motor starting ability | Widely available, slow speed ranges, robust simple construction. Can withstand overspeed. Cheaper than synchronous generators |
| Synchronous - Brushed | Commonly used with petrol or diesel engines. | Low - medium: \$300 - \$500 | 3000, sometimes 1500 | Brushes and slip rings wear out and require replacement. Must be strengthened for over-speeding | Higher efficiency than induction at part-load and better motor starting capability |
| Synchronous - Brushless | Occasionally used with diesel engines | High: \$600 - \$1000 | 1500, 3000 | Not widely available. Repairs are often complex / expensive. Must be strengthened for over-speed | As synchronous-brushed but with better reliability |
| DC | Car or truck alternator | Not Applicable Max. output ≈ 500W | Car > 2000, truck > 1200 | Not suitable for village electrification. Restricted range of appliances. Brushes and slip rings wear out | Very low cost, no controller required. |

Table 9-1 Comparison of Generators suitable for use with Pico Hydro Turbines

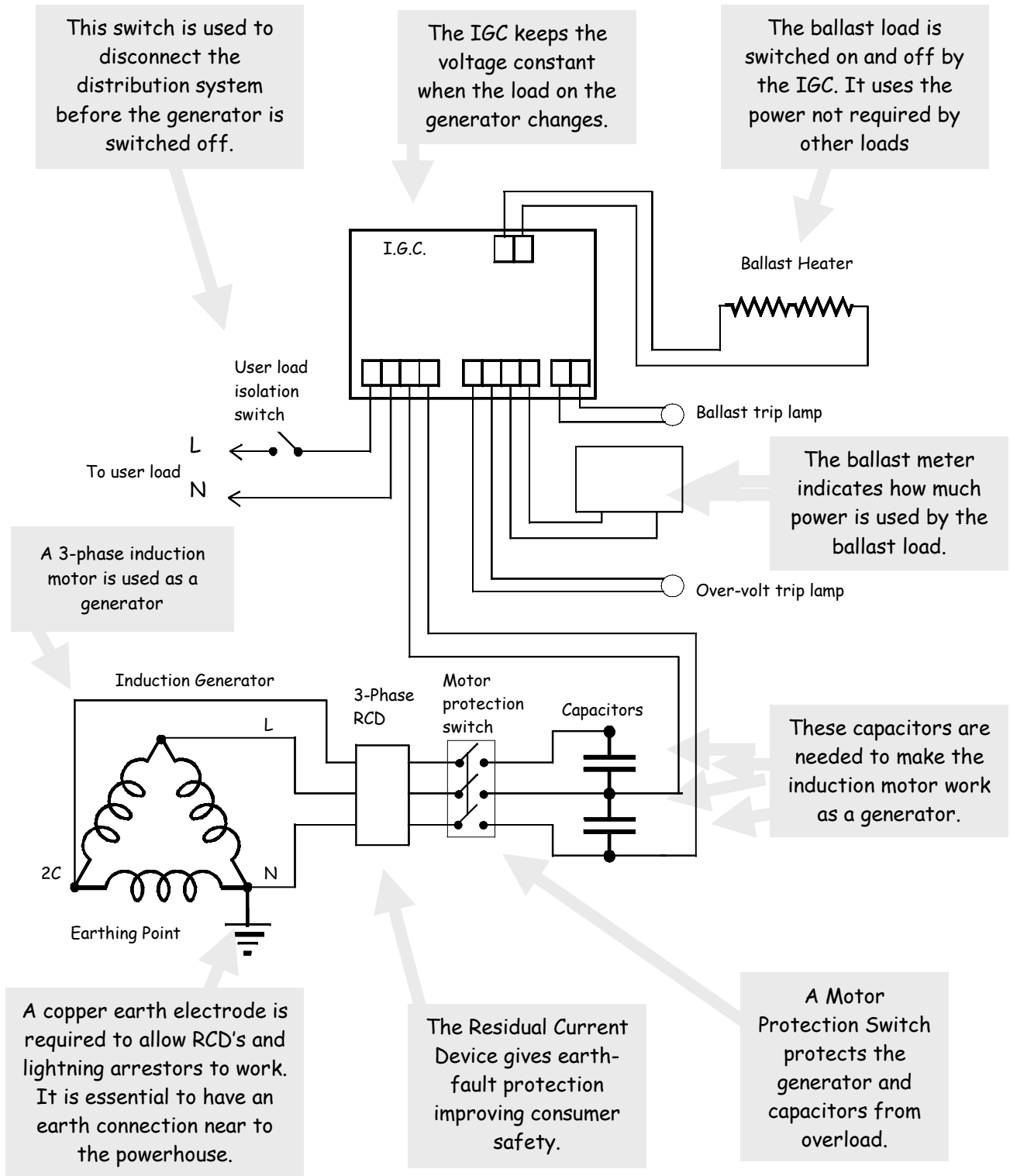

Figure 9-7 Connection of generator and controller

9.6 Electronic Load Control

If the voltage and frequency are not kept at the right level then the user loads connected to the generator can be damaged.

| | Too High | Too Low |
|------------------|--|--|
| Voltage | Motors, televisions and radios can be damaged. the lifetime of lightbulbs and heaters becomes shorter. | Most appliances have reduced performance or fail to operate |
| Frequency | Will not usually cause problems with most consumer loads. Except speed dependant motor loads. | Can cause internal circuits to overheat and fail in radios, TV's and motors. |

Table 9-2 Effect of voltage and frequency variation on loads

The speed of the turbine changes when the load connected to the generator changes. For example, if more lights are switched on then the speed of the turbine will decrease. Since this change of speed affects the voltage and frequency, the load on the generator must be kept constant or the flow of water through the nozzle must be adjusted. The most reliable method of controlling the load and keeping the voltage and frequency constant is by using an electronic load controller.

The speed of an induction generator can be kept near constant by using an IGC (Induction Generator Controller). This device sends any unused power to a ballast (or dump load) so that the total load on the generator remains constant. For example, if the generator produces 1000 Watts and the total load connected by the consumers is only 600W then the IGC will control the switching on and off of the ballast so that the remaining 400W is also dissipated. If the consumer load changes at any time, the IGC will automatically adjust the power diverted to the ballast so that the voltage and frequency are kept constant.

The IGC cannot, however, prevent the generator from becoming overloaded. For example, if the generator is producing 1000W but more than 1000W of load is connected then the voltage will fall and the IGC is unable to prevent this. To avoid overloading, the use of load limiters is

strongly recommended. This is explained in more detail in Section 15.3.

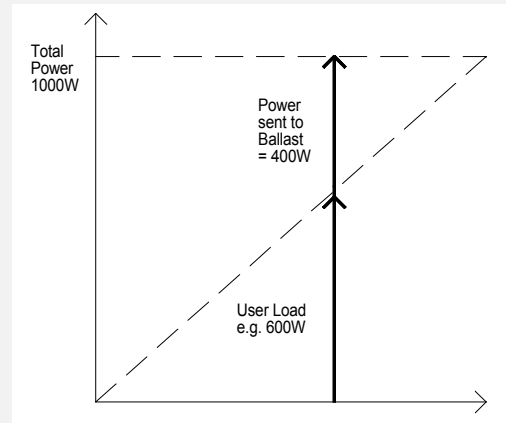

Figure 9-8 Division of power between user load and ballast

The Ballast

The ballast is an essential part of the electronic control system. Great care must be taken with the choice and connection of the ballast. The most common source of problems with induction generator controllers is with the ballast.

Air heaters

Convection heaters are the best type of ballast to use for pico hydro schemes. They are usually reliable and have the longest life. They are sold as electrical room-heaters. Designs that can be mounted on the wall are the safest type. A low-cost 'DIY' design of ballast using cooking rings is shown in Figure 9-9. This will work as a radiant heater when wall mounted on a suitable frame. The cable insulation and frame must be able to withstand very high temperatures. Radiant heaters generally have a shorter life than convection heaters because they operate at a higher temperature.

Water heaters are often used as ballast loads although experience has shown that these often cause problems on small schemes and therefore they are not recommended. Cheap water-heating elements and steel ballast tanks often corrode rapidly. The temperature requires monitoring and cold water must be introduced to the tank before the water boils. Automatic flow control systems can be designed to achieve this but they are complicated and are not cost-effective for pico hydro.

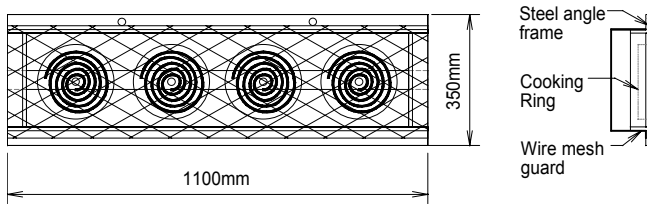

Figure 9-9 Low cost ballast using electric cooking rings

Low Cost Ballast Design

A ballast of this design should be mounted on the wall. The cables must be protected using a heat-resistant sheath and connections made to the heating elements from below.

Calculating the power dissipated

Cooking rings are available with a range of power ratings and are cheap and robust. By connecting two rings in series the voltage is halved and the lifetime is considerably extended. Since the voltage is halved with series connection, the current is also halved and so the power dissipation is therefore quartered. For example, a ballast to dissipate 3.0kW would require 8 rings rated for 1.5kW. That is four pairs of series connected rings across the controller or two of the units shown in Figure 9-9.

$$V/2 \times I/2 = P/4 = 375W \text{ dissipated per ring if series connected in pairs. } 8 \times 375W = 3.0kW.$$

The connection of the cooking rings for this example is shown in the circuit diagram below.

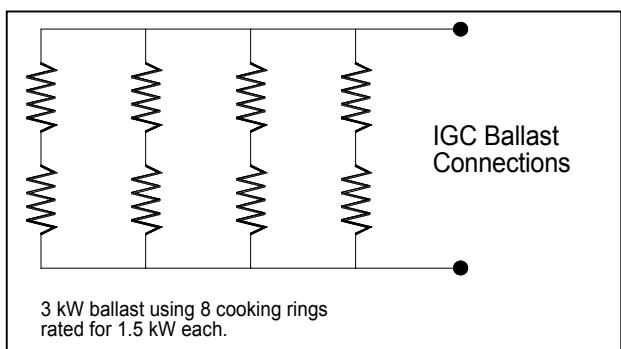

Figure 9-10 Electrical connection of cooking ring ballast (4 pairs of series connected rings)

Protection features of the IGC

Over-voltage trip If the voltage rises too high, then the supply will automatically be disconnected to protect the consumer loads. The over-voltage trip lamp(s) will light to indicate this condition.

Ballast trip: The ballast is automatically disconnected if the ballast is too large or if the ballast connections are shorted out. The ballast trip lamp(s) will light.

Lightning protection: Many IGC designs contain a varistor that minimises the risk of damage to the controller due to indirect lightning strikes.

Meters

The IGC will function without meters fitted. However, these enable the user to maximise their use of the power available and are helpful for identifying the cause of electrical problems.

Ballast meter: This meter indicates the percentage of power being dissipated in the ballast load. It is the most useful meter because it indicates how much spare capacity there is and how close the generator is to being overloaded (when the controller is functioning normally but the meter reads zero).

Voltmeter: This is useful for setting the operating voltage on the controller and for observing the voltage if the generator becomes overloaded. It should be rated for 300V AC and connected to the supply output terminals so that it is protected by the over-voltage trip.

9.7 Alternatives to load control

It is tempting to operate the generator with no load controller present. Two options are available.

Fixing the Load

One method of controlling the voltage and frequency is to have a load connected that exactly matches the output of the generator. However a fixed load is difficult to achieve if more than one consumer is connected and appliances, such as refrigerators, that continually switch on and off cannot be used. It is not recommended

Manual Control of the Turbine Speed

Manual control requires the presence of an operator to correct the flow of water to the turbine and control its speed whenever the load is changing. This method is not recommended for achieving good voltage and frequency regulation and is costly in the long term due to operator wages.

9.8 Selection and Sizing of Generator, Capacitors, Cable and Protection Equipment

Figure 9-7 shows how the generator, capacitors controller and ballast are connected. There are a number of considerations when specifying a motor to use as a generator.

a) Voltage range: The voltage rating of the three-phase induction motor to be used as a single-phase generator must be carefully selected. If the rating is too high, the generator will be unstable. If the rating is too low it will not be possible to achieve the required generator voltage without overheating the windings.

| Type of motor | Motor Rating (kW) | | |
|---------------|-------------------|---------------|---------------|
| | 0.55 - 1.1 | 1.5 - 3.0 | 4.0 - 7.5 |
| 2 pole | $V_{GEN}+6\%$ | $V_{GEN}+3\%$ | V_{GEN} |
| 4 pole | $V_{GEN}+9\%$ | $V_{GEN}+6\%$ | $V_{GEN}+3\%$ |
| 6 pole | $V_{GEN}+12\%$ | $V_{GEN}+9\%$ | $V_{GEN}+6\%$ |

Table 9-3 Recommended motor voltage.

Note that the operating voltage of the generator (V_{GEN}) is usually set slightly higher than the national single-phase voltage to allow for the voltage drop on the distribution system. Table 9-3 shows the recommended motor voltage, in relation to the generator voltage, for different motor sizes and speeds. This will give stable operation and a near optimum efficiency. The reason why smaller and slower speed generators require higher motor voltage ratings is to compensate for their lower power factors. **The acceptable limits for the voltage rating are +/-6% of the recommended voltage.**

Example: If a 4-pole 3kW motor is to be used to generate 245 Volts, using Table 9-3, the recommended motor voltage is 245V +6%, i.e. 260 Volts. The acceptable limits of motor voltage are 245V (recommended value -6%) and 275V (recommended value +6%).

The effect of increasing the voltage of the motor can be achieved by increasing the frequency by the same percentage. Varying the frequency has drawbacks as shown in Table 9-2. However, small increases of up to about 6% are acceptable. For example, if 230 Volts is a standard voltage available for the 3kW motor described above, this can be used at 6%

increased frequency in order to generate at 245 Volts.

The terminal box of many induction motors allows connection in a star or delta pattern giving the possibility of two voltage ranges. The voltage range for star and delta is given on the nameplate. Either of the following is suitable for a 220V scheme:

- Either 380-415V star / 220-240V delta
- Or 220-240V star / 127-139V delta

Note: Motors of 3kW and above are often wound for 660-720V star/ 380-415V delta. These are not suitable as 220-240V generators. Most manufacturers will supply motors wound to the voltage you require, with a longer delivery time.

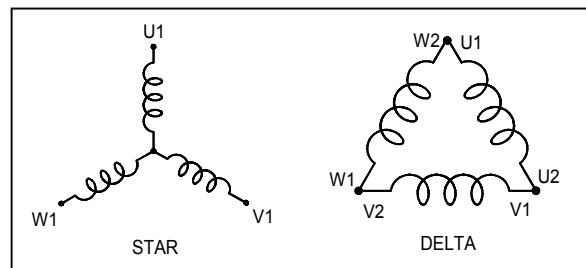

Figure 9-11 The two voltage ranges are possible with many induction motors by connecting the windings in 'Star' or 'Delta'

b) Frequency: The frequency rating should be the same as that required by the loads (i.e. 50Hz or 60Hz). For a direct drive system, the generator speed must be matched to the turbine speed. Note that the generator speed is always about 10% higher than the motor speed. Shaft speeds for common sizes of induction generator are given in the table below. Select a machine with the correct number of poles.

| No. of poles | 50 Hz | 60Hz |
|--------------|-----------|-----------|
| 2 | 3,120 rpm | 3,750 rpm |
| 4 | 1,560 rpm | 1,875 rpm |
| 6 | 1,040 rpm | 1,250 rpm |

Table 9-4 Examples of induction generator shaft speeds

c) IP Number: Select a motor which is IP 55. The IP number is a measure of how easily liquid or dust (e.g. flour) can enter the machine. IP 55 models are resistant to either and therefore suitable for hydropower applications.

d) Insulation Class: Always select the highest available winding insulation class. The

two most common types are B and F. Class F has a longer life than Class B. For the same operating temperature, Class F insulation will last four times as long as Class B.

d) Power Rating: Estimate the maximum electrical power output, P_{max} , by calculating the hydraulic power and assuming an overall efficiency of 50% (unless actual efficiencies are available). Use P_{max} and the generator voltage (V_{GEN}) to work out the operating current.

$$I_{op} = 1.1 \times \frac{P_{max}}{V_{GEN}}$$

where I_{op} = maximum operating current
 V_{GEN} = generator voltage

The (rated) line current of the motor, I_{line} , must be greater than or equal to the operating current:

$$I_{line} \geq I_{op}$$

Example: A 2-pole generator is to be used on a pico hydro with a maximum electrical power output of 1,500 Watts. The national voltage is 220 Volts and the generating voltage 220V + 6%, i.e. 233V, calculate I_{op} :

$$I_{op} = 1.1 \times 1500/233 = 7.1 \text{ Amps.}$$

A 2.2kW 2-pole motor is available which, when delta connected, has a voltage rating of 240Volts (the recommended voltage as given in Table 9-3), and a line current of 7.6 Amps. This motor is ideal for use at this site.

Over-current protection

The generator windings and cables must be protected from excessive currents. These can cause them to overheat and fail. High currents also damage the capacitors.

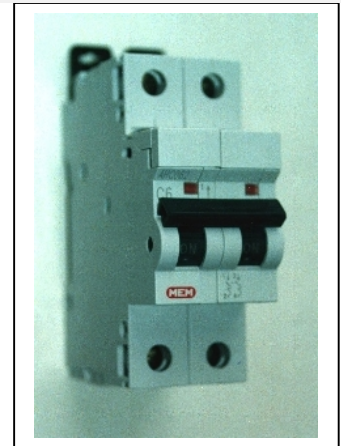

Figure 9-12 Motor Protection Switch

For maximum protection a motor protection switch should be used as the tripping current can be adjusted to

the precise current rating of the generator. Typical current ranges for motor protection switches are 2-4A, 4-6A, 6-10A, 10-16A, 16-20A, 20-24A. For the 2.2kW motor in the example, a 6-10A motor protection switch would be ideal. The alternative to the motor protection switch is the Miniature Circuit Breaker (MCB). However, these have the disadvantage of being only available with fixed current ratings and so cannot be set to the line current of the motor.

Figure 9-13 Miniature Circuit Breaker



Current rating of the cable

The cable current rating should be at least 40% greater than the maximum current rating of the Motor Protection Switch or MCB. Conduit should be used for the powerhouse wiring. The current ratings given, apply to single-core, PVC insulated cables which conform to BS 6004, BS 6231 and BS6346.

| CSA of copper cable (mm ²) | Current capacity (Amps) |
|--|-------------------------|
| 1.0 mm ² | 13.5A |
| 1.5 mm ² | 17.5A |
| 2.5 mm ² | 24A |
| 4.0 mm ² | 32A |
| 6.0 mm ² | 41A |
| 10.0 mm ² | 57A |

Table 9-5 Current carrying capacity of single-core electric cables enclosed in conduit

Selection of Capacitors

The excitation capacitors (C-2C) required to enable a 3-phase induction motor to work as a single-phase generator will determine the frequency of the electricity produced. The capacitance required to generate at a particular frequency varies between one motor and another and depends on whether the motor voltage rating is higher or lower than the recommended value in Table 9-3. The basic rule for calculating the required capacitance C is as follows:

$$C(\mu F) = k \times \frac{I_{line}}{V_{GEN} \times 2\pi f}$$

where:

$$\pi = 3.1416$$

f = frequency of the generator (Hz)

k depends on the voltage rating of the motor which is used. As described earlier, the acceptable limits for the motor voltage rating are +/-6% of the recommended value (given in Table 9-3). The multiplying factor, k , can be found from Table 9-6:

| | |
|---|------------|
| Recommended voltage is used (as in Table 9-3) | $k = 0.35$ |
| Recommended voltage +6% is used | $k = 0.3$ |
| Recommended voltage -6% is used | $k = 0.45$ |

Table 9-6 Values of multiplying factor, k .

The value of C , as calculated above, should be rounded up to the nearest $5\mu\text{F}$ and the $2C$ ($2 \times$ the calculated value, C) rounded down to the nearest $5\mu\text{F}$. It will probably be necessary to adjust these values further in order to obtain the exact frequency required. The total capacitance C and $2C$ should be made up of a number of individual capacitors. This will allow some adjustment of the C - $2C$ to be made during installation. The voltage rating of the capacitor should be comfortably greater than the maximum generator voltage, e.g. capacitors should be rated for 380V AC if generating at around 220V. They should preferably have a screw fitting underneath to allow them to be securely mounted (see Figure 9-5). The 'motor-run' type of capacitors should be used as these are rated for continuous use. 'Motor-start' capacitors are only designed for intermittent use and are therefore not suitable. For information about connection of the capacitors, see Section 9.9.

Selection of the IGC

The power rating for the controller must be equal to or greater than the maximum electrical power output of the generator, P_{max} . A good quality IGC from a reputable manufacturer must be used as it cannot be repaired by the operator.

Additional electrical protection

1. A **lightning arrester** should be fitted close to the powerhouse. This will protect the generating equipment from high voltages caused by nearby lightning strikes and act in addition to the varistor that protects the IGC (see Section 16).

2. The cables in the powerhouse must be protected from mechanical damage by using **cable conduit**. The conduit must be fixed to the generator connection box and to the controller/capacitor casing with threaded fittings. This provides an additional layer of insulation, prevents the cables from being pulled accidentally out of their connection boxes and provides a watertight connection.

3. An **isolation switch** is needed to disconnect the distribution system as the generator must be started and stopped without user load connected. Also it may be necessary to disconnect the user loads when driving mechanical loads. A mains switch or an MCB can be used as an isolation switch.

9.9 Installation and Connection

In addition to Figure 9-7 the following guidelines should be used when installing and connecting the generator and additional electrical equipment.

Connecting the generator

As described under "Generator Selection" in Section 9.8, an induction motor with either of the following connection possibilities is suitable for a 220V scheme:

- a) 380-415V star / 220-240V delta
- b) 220-240V star / 127-139V delta

Using motor a), the metal links should be arranged in the terminal box to give the delta connection. Using motor b), the links are arranged to give the star connection. This is illustrated in Figure 9-14. The three cables to the RCD are tightened under the terminal washers at the generator.

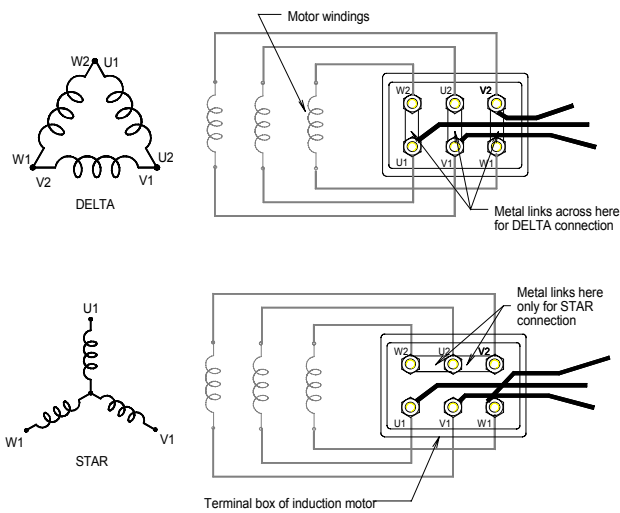

Figure 9-14: Make sure the metal links are arranged correctly in the terminal box to give STAR or DELTA connection with the correct voltage range.

Connect the earth electrode to any of the three terminals if the delta connection is used. For a star connected motor, use any of the three separate terminals but not the star point attached to the metal links. The earthed terminal becomes the neutral (N) and the remaining two terminals are labelled live (L) and 2C. It does not matter which way round L and 2C are as this will be determined when the generator is commissioned.

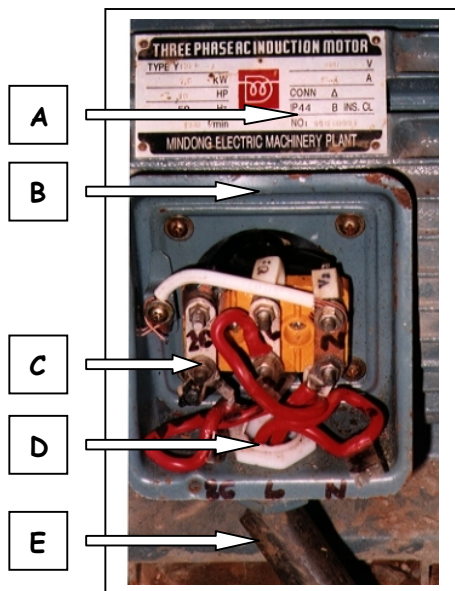

Figure 9-15 Connections inside generator terminal box. Several problems have been identified and solutions given in the Table 9-7

| | Problem | Solution |
|---|--|---|
| A | IP 44 only | Use IP 55 which have better protection against liquid and dust |
| B | No seal on connection box | |
| C | Loose connections causing over-heating | Tighten connections every 6 months and use 'shake-proof' washers at terminals |
| D | Lack of colour coding | Cables of different colours should be used to avoid wiring errors. |
| E | Pipe used as conduit | Use cable conduit and conduit connectors to terminal box. (see photo) |

Table 9-7 Problems with generator connections

Installation of the RCD

This should be mounted on the wall between the generator and controller. Ideally it should be enclosed in a purpose built housing with a transparent front allowing the operator to see when a trip occurs.

Connecting Capacitors

Connect the 3-phase RCD (2C, L, N) and motor protection switch as shown in Figure 9-7. The capacitor connections will depend on the number of capacitors that are used. For example, a particular generator requires $C=52\mu\text{F}$, $2C=104\mu\text{F}$. The capacitors available are $5\mu\text{F}$, $15\mu\text{F}$ and $30\mu\text{F}$. Rounding C up to $55\mu\text{F}$ and $2C$ down to $100\mu\text{F}$ allows these to be used and connected as shown in Figure 9-16. The $100\text{k}\Omega / 2\text{Watt}$ resistors are used to discharge the capacitors if the protection switch or RCD trip, preventing shock.

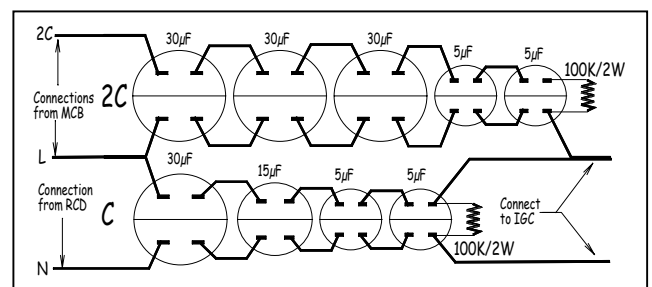

Figure 9-16 Suitable connection of capacitors if $C= 52\mu\text{F}$

Connecting several capacitors of different sizes together, to make up the total values of C and $2C$, enables small adjustments to be made and allows the frequency to be corrected when the generator is commissioned. Removing small amounts of capacitance increases the frequency. If the C capacitance is reduced by a certain value then $2C$ should be reduced by approximately twice that value.

Most large capacitors have two connections on each side and cables may either be soldered in place or attached using suitable connectors that are usually clamped onto the end of the wires with the aid of crimping pliers. Connectors and the appropriate tool should be used if they are available as soldering is impractical in isolated locations and prevents on site adjustment. Damaged capacitors are also difficult to replace if the connections are soldered. When crimping, ensure that the connections are very tight, both between the wire and crimp and crimp and capacitor terminal.

Installing the IGC.

The IGC is normally housed in a metal case that is mounted on the powerhouse wall. The case should preferably have a hinged door and be large enough to comfortably accommodate the capacitors in addition to the IGC circuit board.

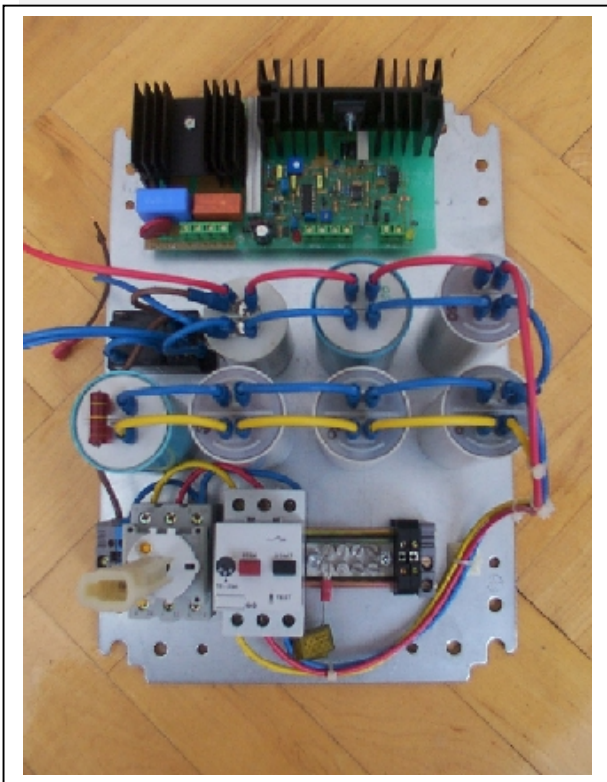

Figure 9-17 Correctly installed IGC and Capacitors

The trip lamps on the IGC may be mounted are usually mounted the circuit board and in the door of the metal case.



Follow these instructions for IGC installation:

- IGC must be installed vertically, in a well-ventilated and dry location.
 - Connect according to labelling of terminals and label all connecting wires.
 - The case must have ventilation holes that allow a flow of cool air to pass over the finned heat sinks of the IGC. The air vents should be above and below the IGC, covered with wire mesh and a solid protective cover raised above the surface that prevents entry of dripping water (as shown in Figure 9-18).
 - Check that no cables are touching the heat sinks as the insulation could be damaged when the controller is operating.
 - If housed in a metal case, then the case must be earthed.
 - The ballast heater must not be installed underneath the IGC but above or at the side.
- The case must be locked, with a 'high voltage' warning label on the door. A second label should state that the box must not be opened unless the IGC has been isolated from the Generator

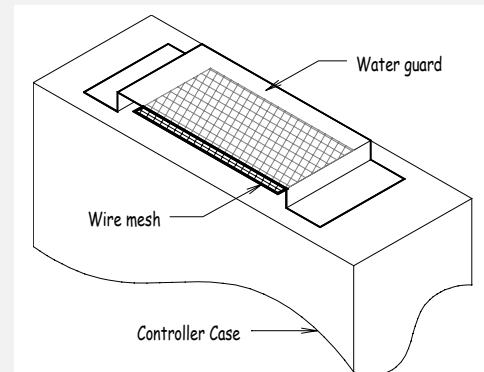

Figure 9-18 Suitable design of air vent for controller and capacitor casing. A vent should also be provided at the bottom of the case to allow air-flow over the components