

PLAY PANELS 2014

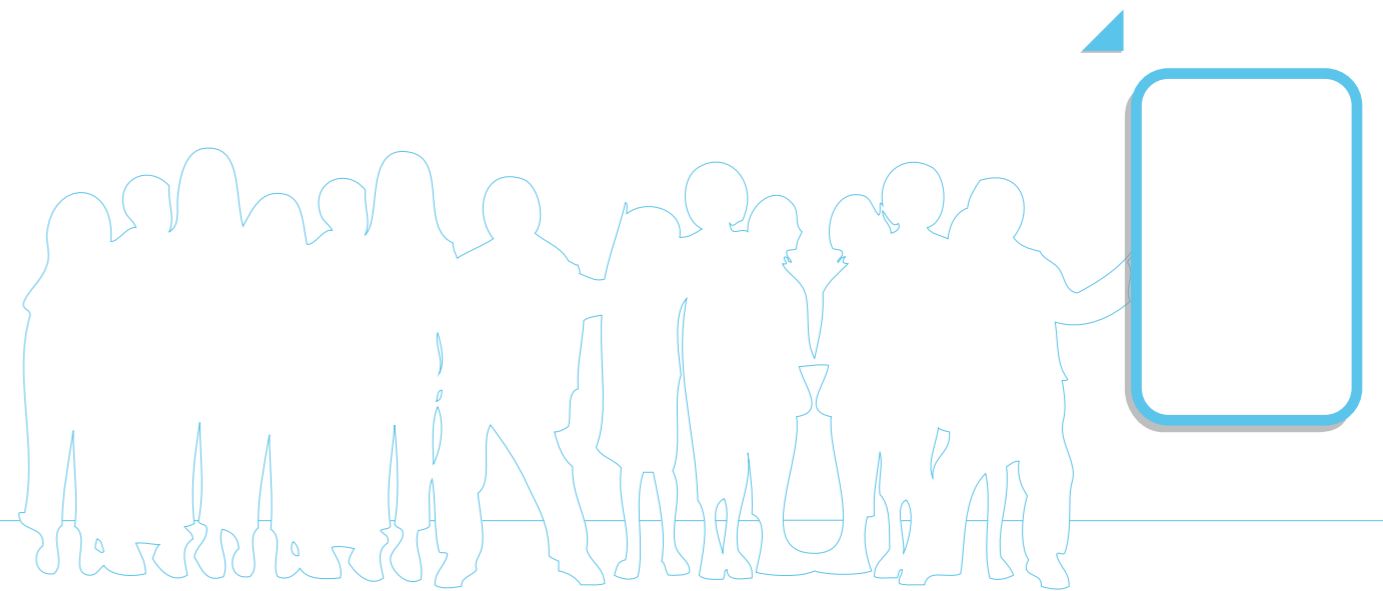

PLAY PANELS



SUMMARY

- ▲ STANDARD 840x580
- ▲ CUSTOM (BRANDED)
- ▲ REFERENCES

 **STANDARD**

 840x580

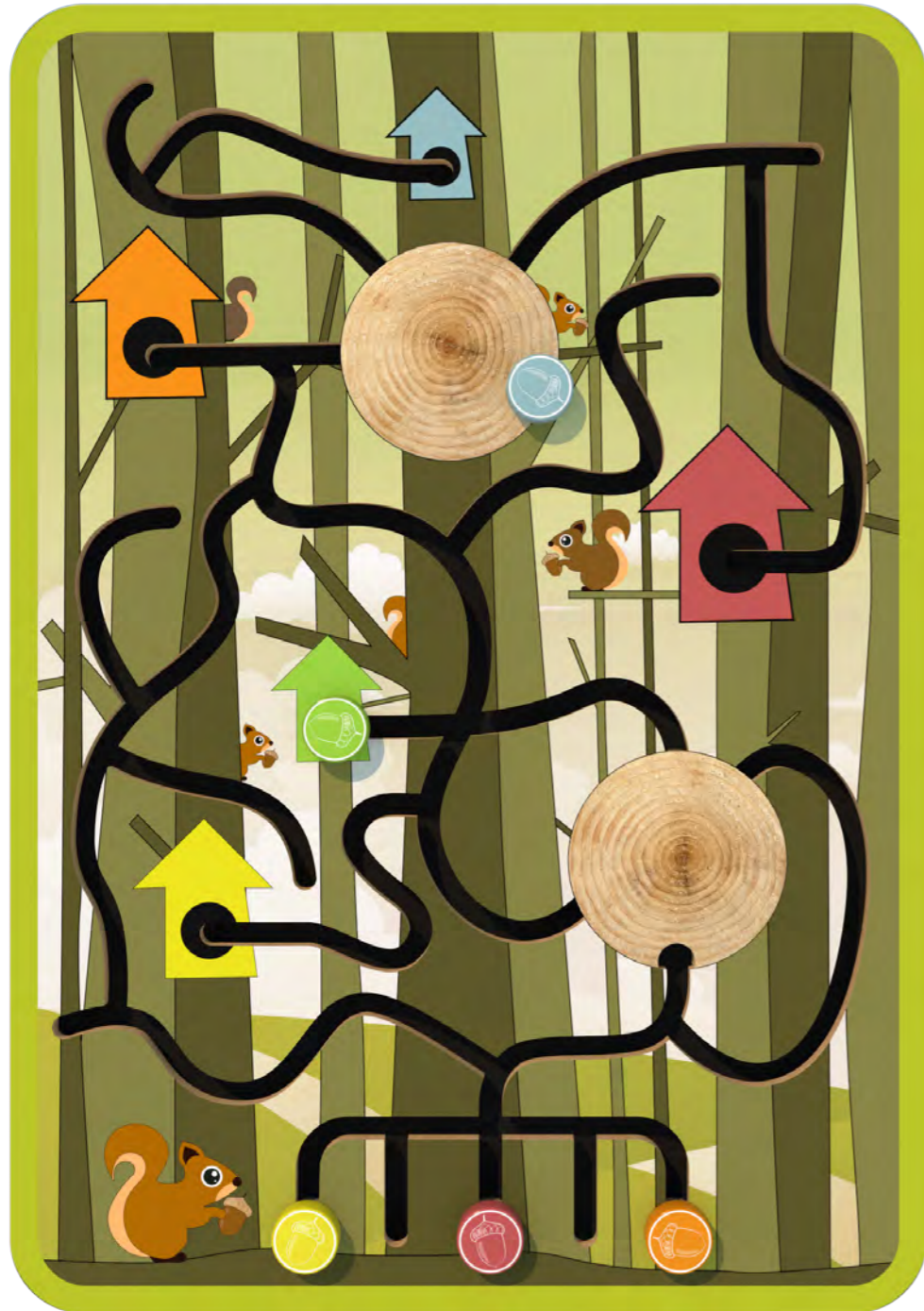

DETAILS



SQUIRREL

This play panel is dedicated for all the children that are excited by taking new challenges and learning in a funny way. This activity helps the young generations interested in biology improving their knowledge of the Animal world while developing their logical and analytical skills. It's a great game to play alone or with friends. Let's help the Squirrel preparing for winter time!

FRONT / SIDE VIEW

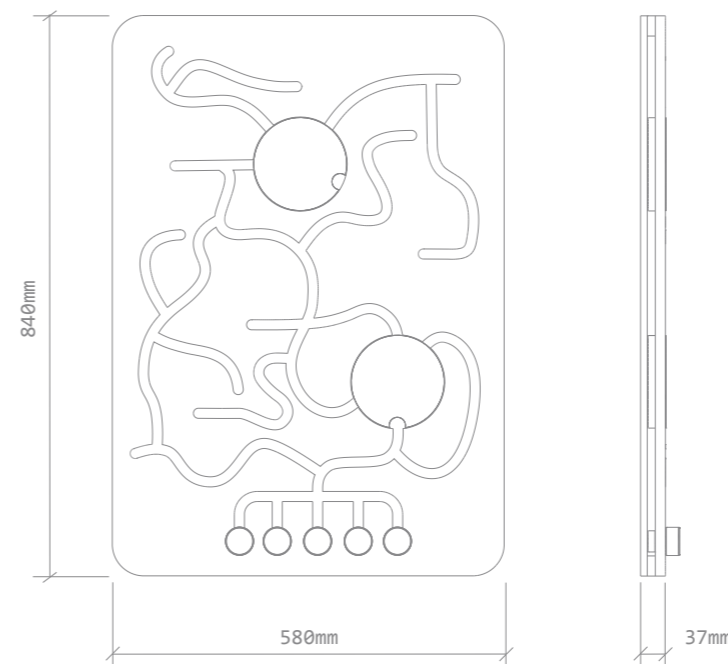

DEVELOPMENTAL BENEFITS

Agility
Logic
Dexterity
Reflexes
Motor Skills

AGE RANGE

3-10

FEATURES

Ergonomically-designed for ease of use
Made to improve matching and analytics skills
Visually attractive to encourage creativity
Easy cleaning



DETAILS

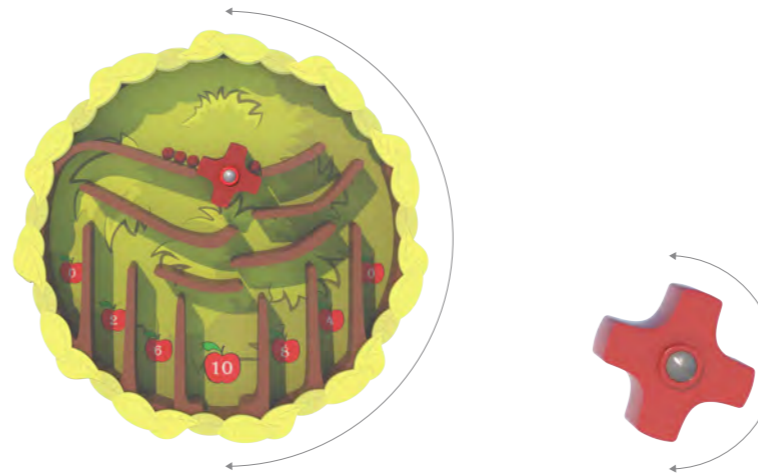

TREE

This activity was developed for children that feel more comfortable with numbers. The purpose is to bring new mathematical perspectives to children's world. It's a great game to play alone or with friends while getting a funny introduction to mathematics. Releasing the balls and turning the treetop, they will always try to get the best score.

FRONT / SIDE VIEW

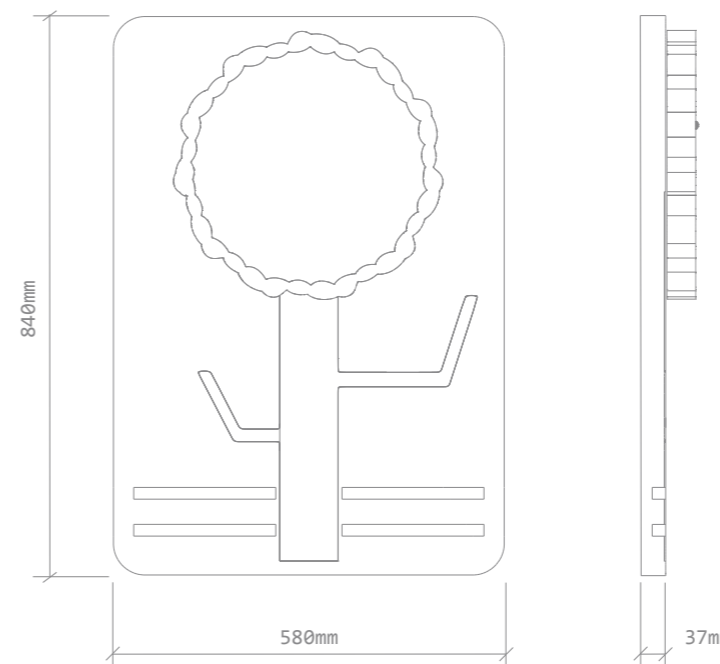

DEVELOPMENTAL BENEFITS

- Agility
- Logic
- Dexterity
- Reflexes
- Motor Skills

AGE RANGE

3-10

FEATURES

- Ergonomically-designed for ease of use
- Made to improve matching and analytics skills
- Visually attractive to encourage creativity
- Easy cleaning



DETAILS

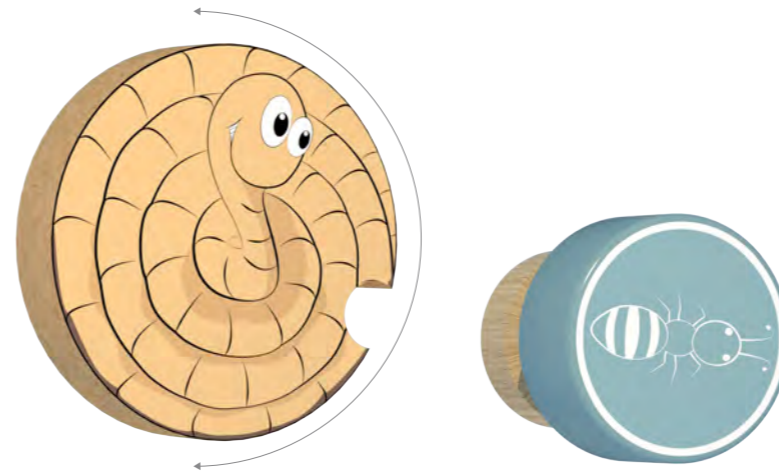

ANTS

This activity was developed to help kids improving their dexterity and analytical skills learning from the ant's community. It's a great game to play alone or with friends and get a better view of the animal world.

FRONT / SIDE VIEW

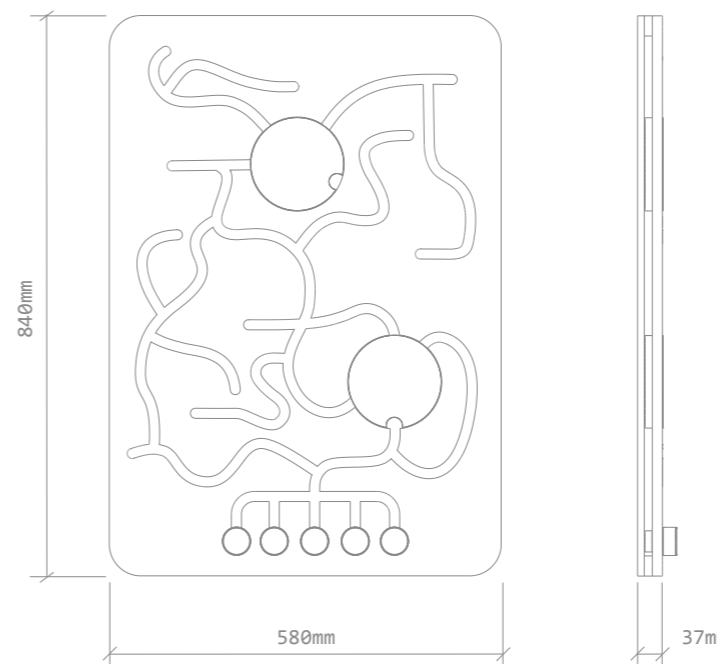

DEVELOPMENTAL BENEFITS

Agility
Logic
Dexterity
Motor Skills

AGE RANGE

3-10

FEATURES

Ergonomically-designed for ease of use
Made to improve matching and analytics skills
Visually attractive to encourage creativity
Easy cleaning



DETAILS

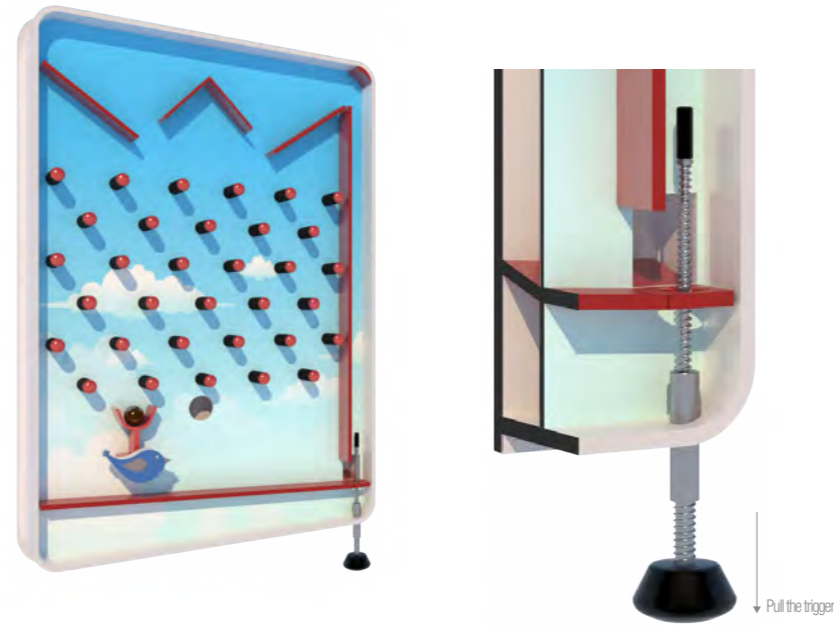

HIDDEN EGG

This game was developed to improve the agility and dexterity of the children. They have to launch the “egg” in the air using the trigger and help the bird catch his egg and bring it back to his nest. The egg is here represented as a ball.

The idea is to shed the light on of the importance of animals in nature. Let's help Mr. Bird take care of his eggs!



FRONT / SIDE VIEW

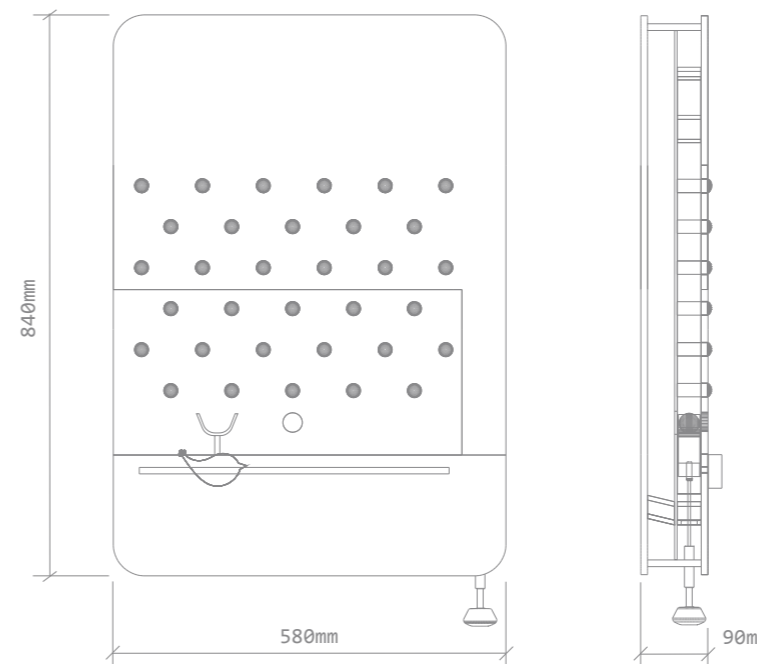

DEVELOPMENTAL BENEFITS

Visual
Tactil
Reflexes
Motor Skills

AGE RANGE

3-10

FEATURES

Ergonomically-designed for ease of use
Made to improve reflexes and motor activity of children
Visually attractive to encourage creativity
Easy cleaning

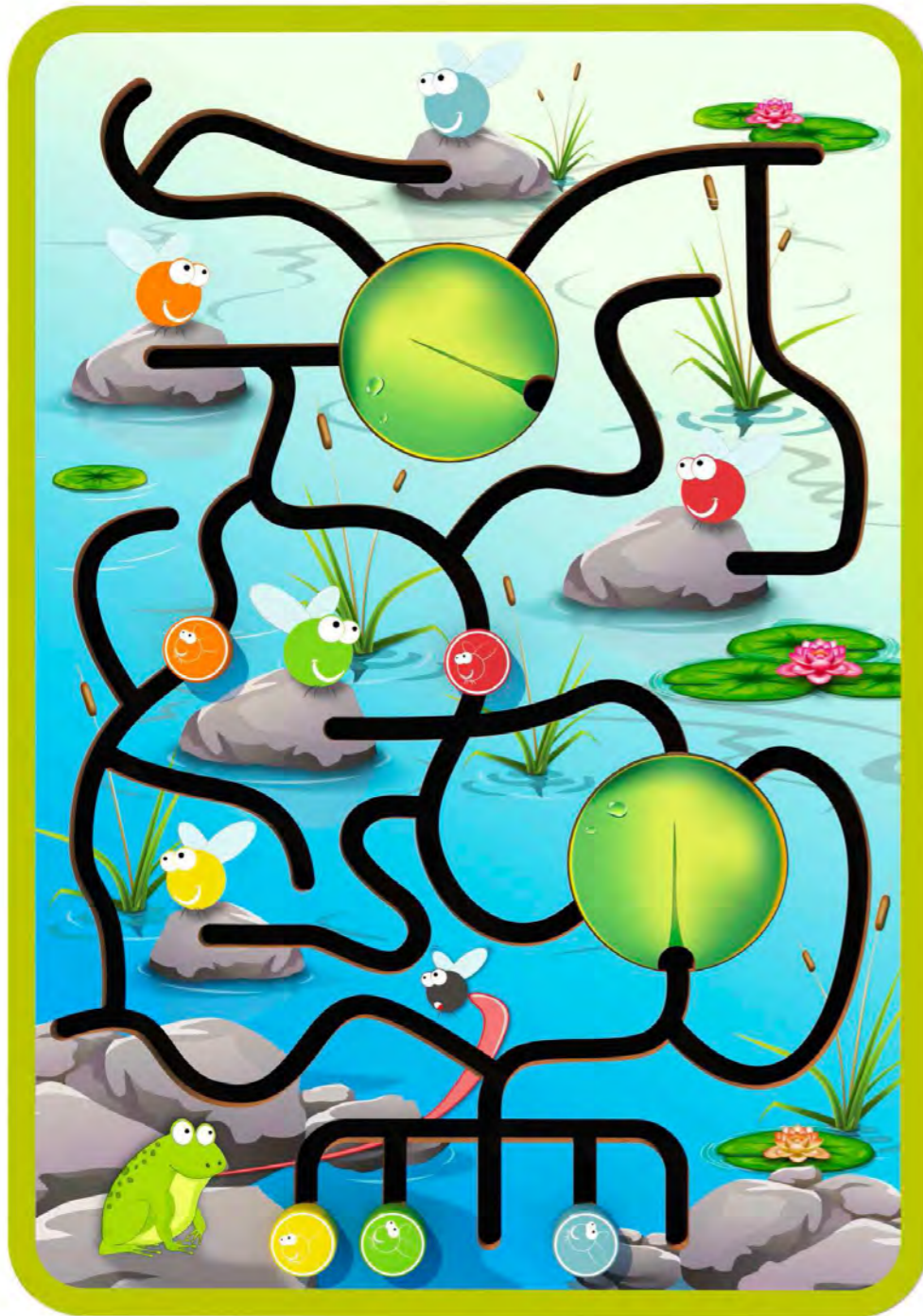

DETAILS

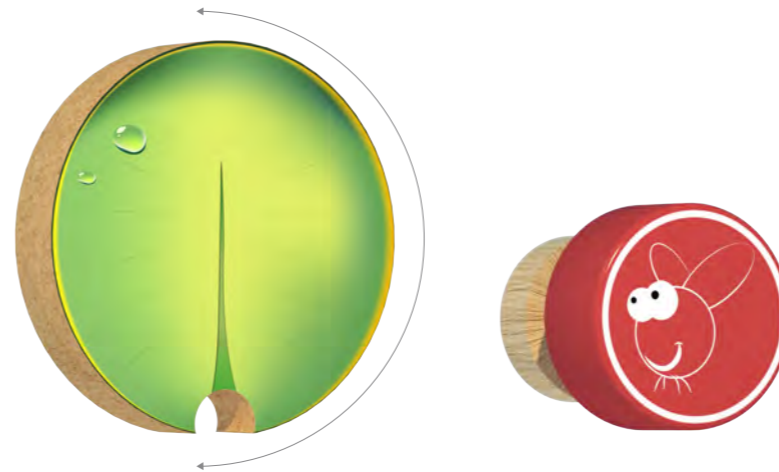

FROG vs FLIES

This game was developed to improve the agility and dexterity of the children. It's a great game to play alone or with friends. Children have to do their best to bring the flies in a safe place where the frog cannot catch them.

FRONT / SIDE VIEW

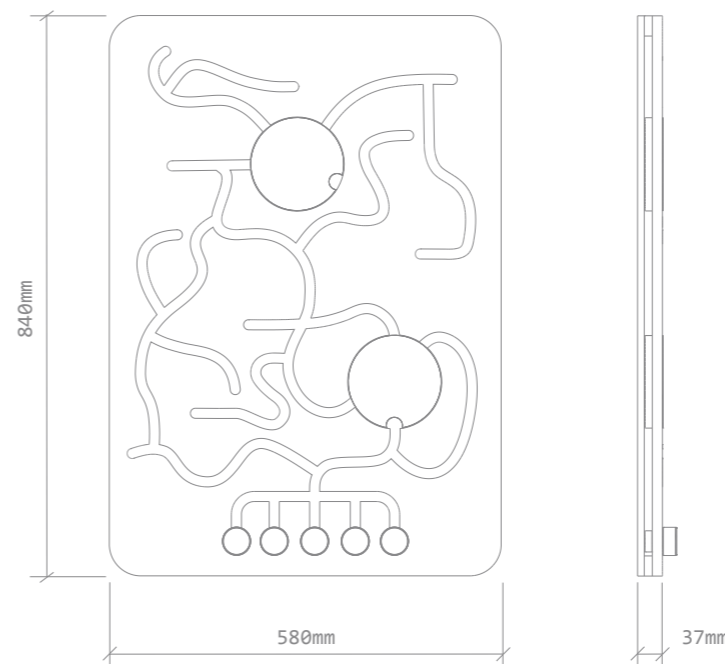

DEVELOPMENTAL BENEFITS

Agility
Logic
Motor Skills

AGE RANGE

3-10

FEATURES

Ergonomically-designed for ease of use
Made to improve logical and analytics skills
Visually attractive to encourage creativity
Easy cleaning

DETAILS

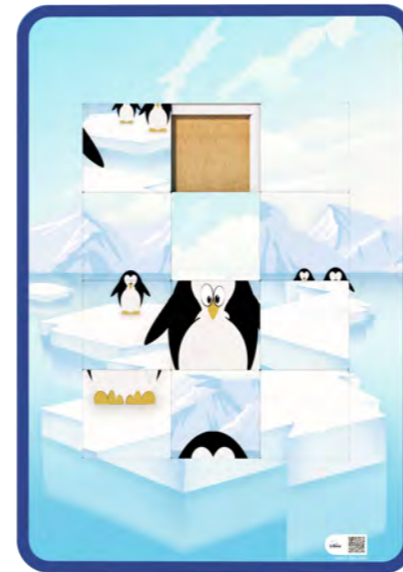

PUZZLE

People have long known that puzzles present many benefits for children as they develop. The accomplishment of achieving a goal brings so much satisfaction to a child. We like the way they challenge the way they think and how they exercise their minds with appealing graphs and figures.

FRONT / SIDE VIEW

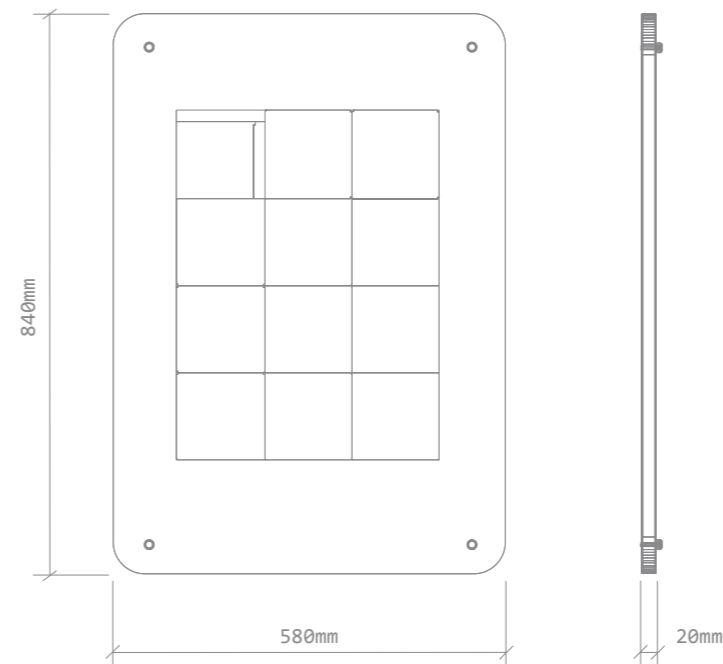

DEVELOPMENTAL BENEFITS

Physical
Cognitive
Emotional
Creativity

AGE RANGE

3-10

FEATURES

Ergonomically-designed for ease of use
Visually attractive to encourage creativity
Easy cleaning



DETAILS

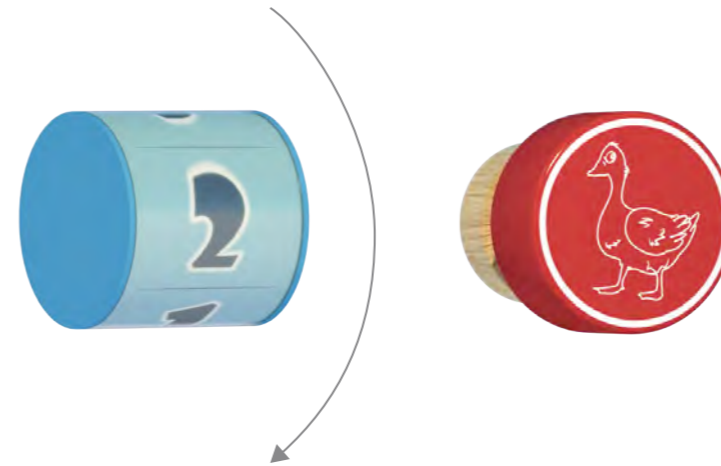

GOOSE

This play panel is dedicated for all the children that are excited by taking new challenges and learning in a funny way. This activity helps the young generations to test the basics capabilities in mathematics while developing their logical and analytical skills. It's a great game to play alone or with friends (4 max). Let's help the Goose taking off.

FRONT / SIDE VIEW

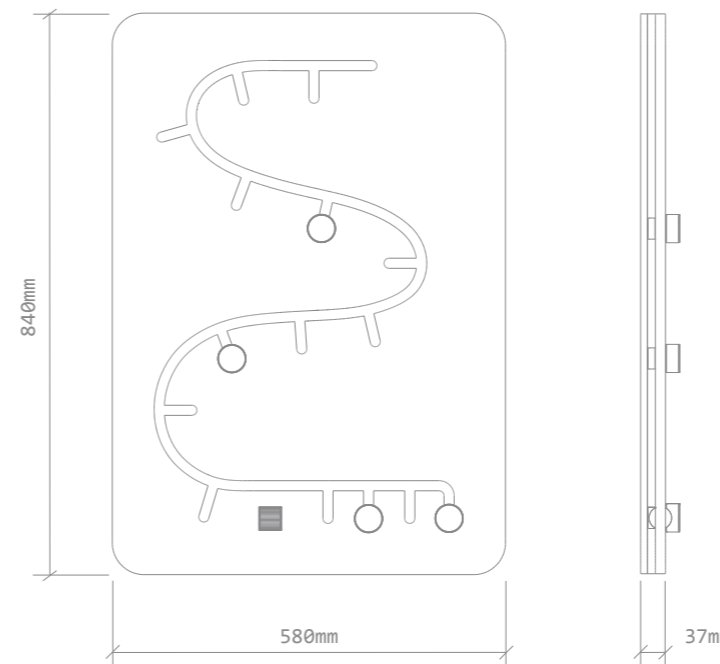

DEVELOPMENTAL BENEFITS

Agility
Logic
Motor Skills

AGE RANGE

3-10

FEATURES

Ergonomically-designed for ease of use
Made to improve logical and analytics skills
Visually attractive to encourage creativity
Easy cleaning



DETAILS



MEMORY

Memory has long been a favorite game for all generations. It is very easy to play. The objective of this game is to rotate the pieces one by one and try to match the animals as fast as possible. It requires observation, concentration and a good memory to win.

FRONT / SIDE VIEW

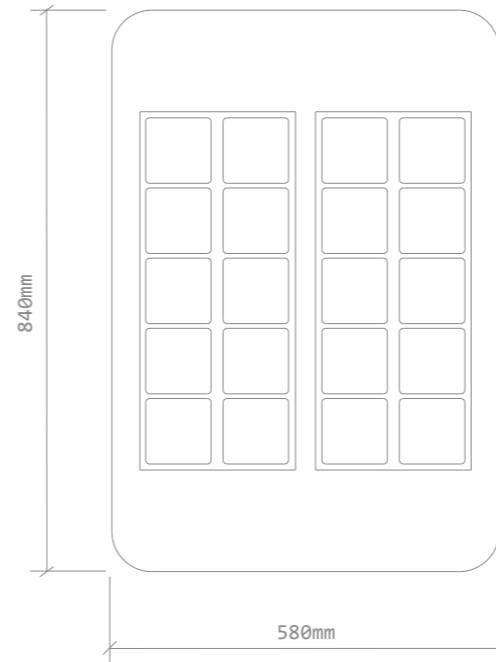

DEVELOPMENTAL BENEFITS

- Agility
- Logic
- Dexterity
- Concentration
- Motor Skills

AGE RANGE

3-10

FEATURES

- Ergonomically-designed for ease of use
- Made to improve matching and analytics skills
- Visually attractive to encourage creativity
- Easy cleaning



FRONT / SIDE VIEW

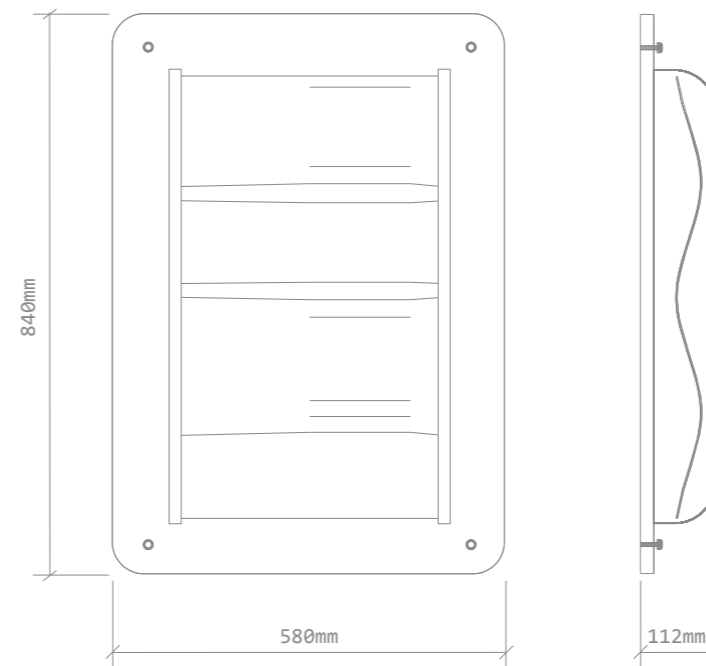

MIRROR

Reflections always intrigued children. This play unit was created for this purpose, to twist and bend their own figure and pull the imagination and creativity to see your distorted image. Is sure that it will boot many smiles and laughter.

DEVELOPMENTAL BENEFITS

Imagination
Creativity
Perception

AGE RANGE

3-10

FEATURES

Ergonomically-designed for ease of use
Visually attractive to encourage creativity
Easy cleaning

 **CUSTOM**

 DECATHLON



DETAILS

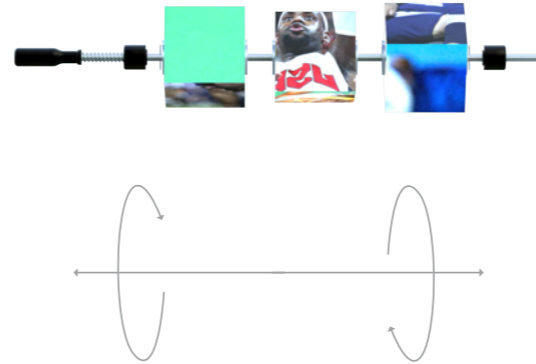

KIKKER PUZZLE

This game was developed for Decathlon in order to improve the experience of shopping with children. In line with their sport activity, this play panel is a great mix of logic, agility and sport culture. It's a great game to play alone or with friends. The goal is to push, pull and rotate the handlebars in order to assemble a puzzle that depicts a French famous sport such as soccer, rugby tennis or basketball.

FRONT / SIDE VIEW

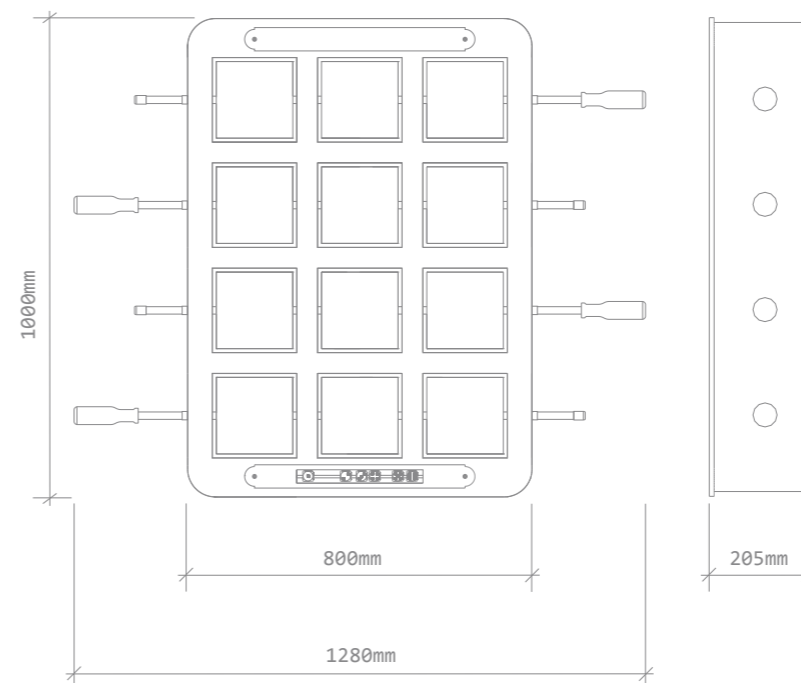

DEVELOPMENTAL BENEFITS

Agility
Logic
Dexterity
Reflexes
Motor Skills

AGE RANGE

3-10

FEATURES

Ergonomically-designed for ease of use
Made to improve logical and analytical skills
Visually attractive



DETAILS

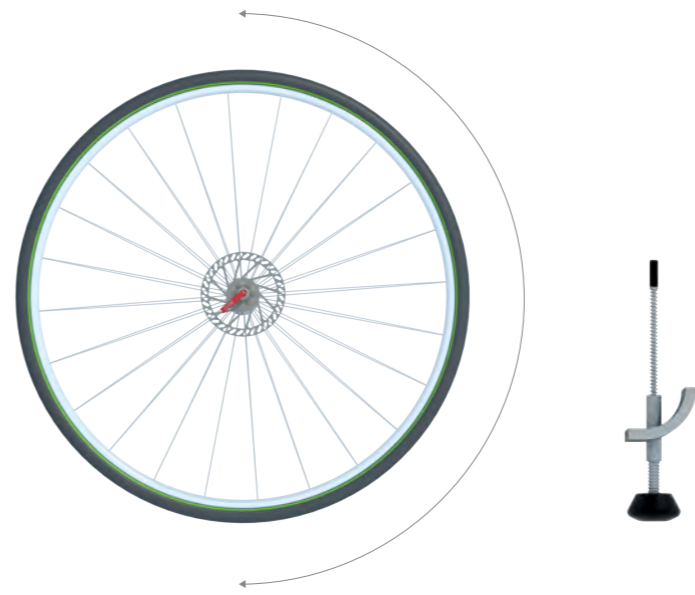

PSYCLE PINBALL

This game was developed for Decathlon in order to improve the experience of shopping with children. In line with their sport activity, this play panel is a mix of cycling and pinball game. The children have to pull the trigger and rotate the bicycle wheel in order to avoid obstacles and finish the race with the best sweater!

FRONT / SIDE VIEW

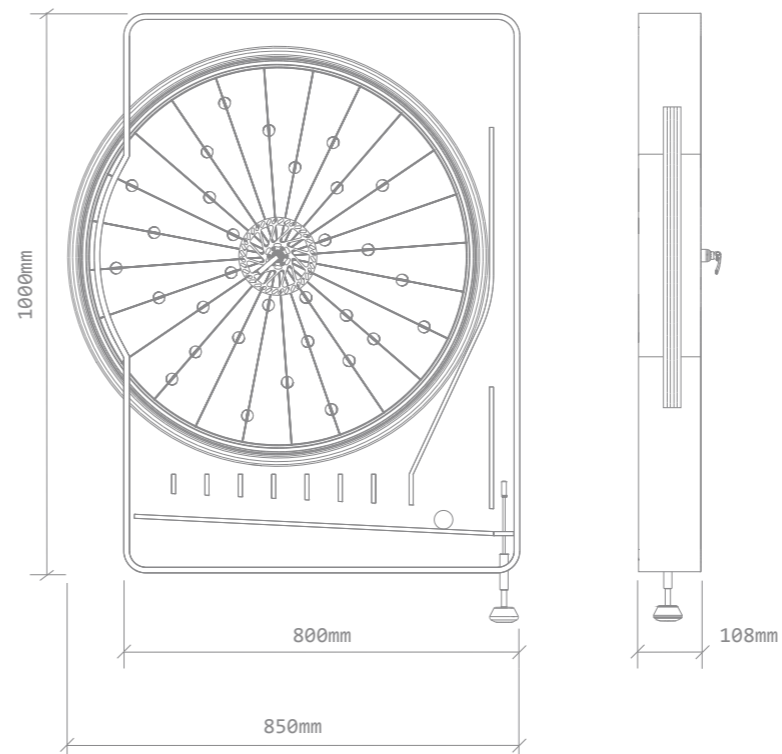

DEVELOPMENTAL BENEFITS

Agility
Dexterity
Motor Skills

AGE RANGE

3-10

FEATURES

Ergonomically-designed for ease of use
Made to improve motor skills
Easy cleaning

 **CUSTOM**

 CASTORAMA

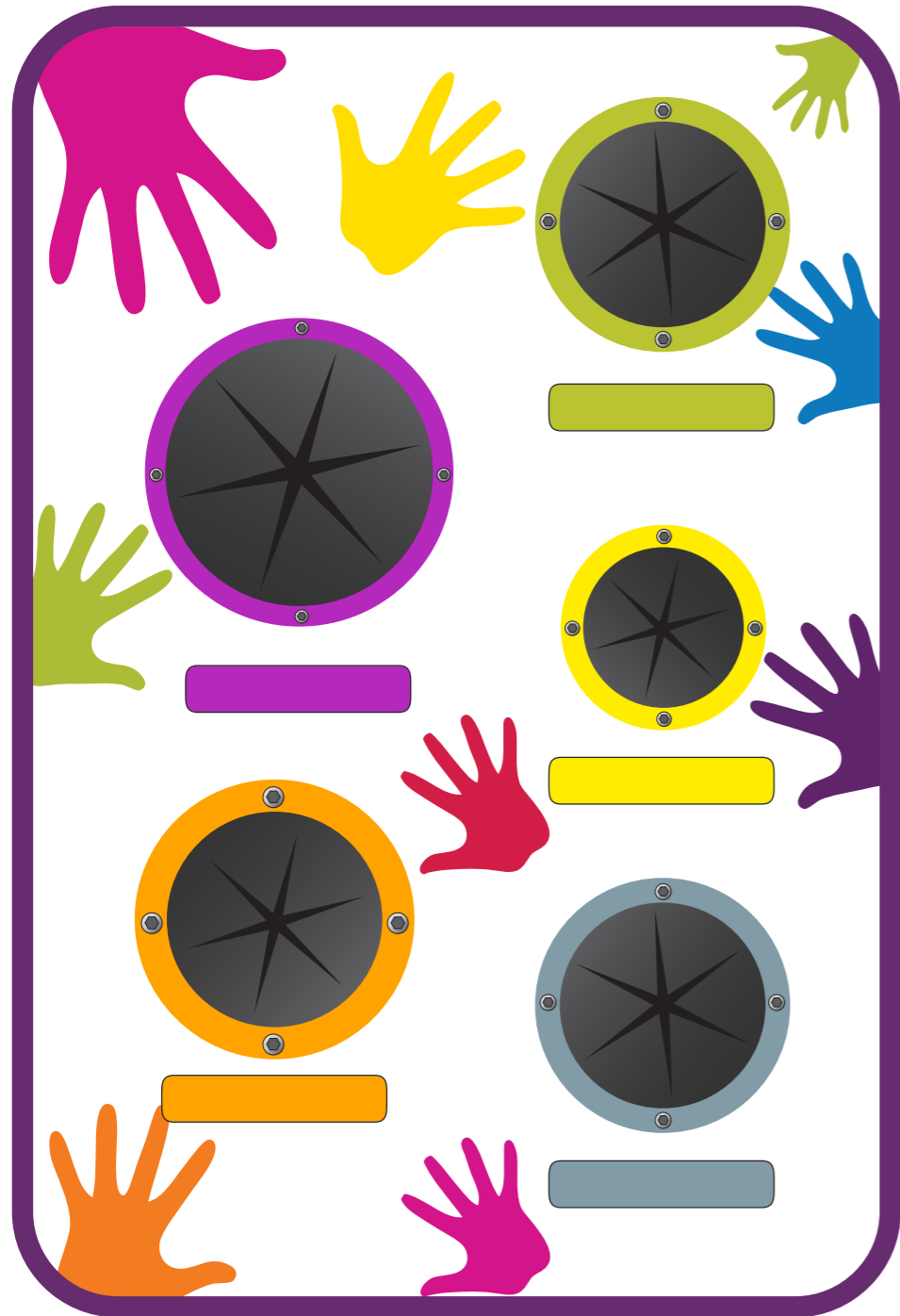

DETAILS

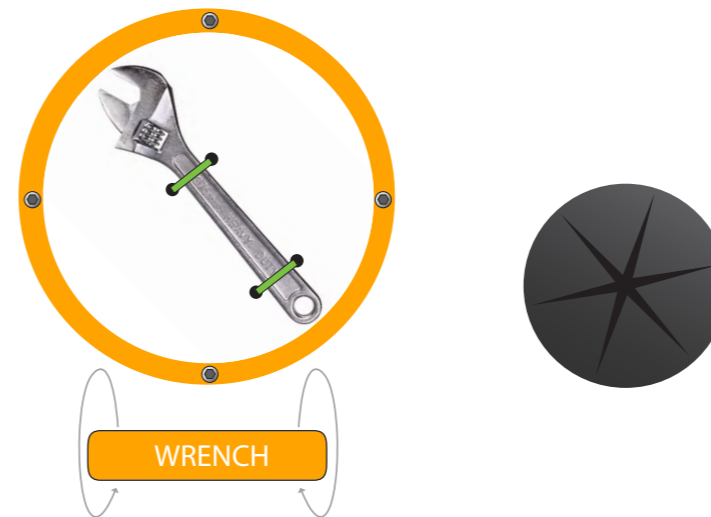

FRONT / SIDE VIEW

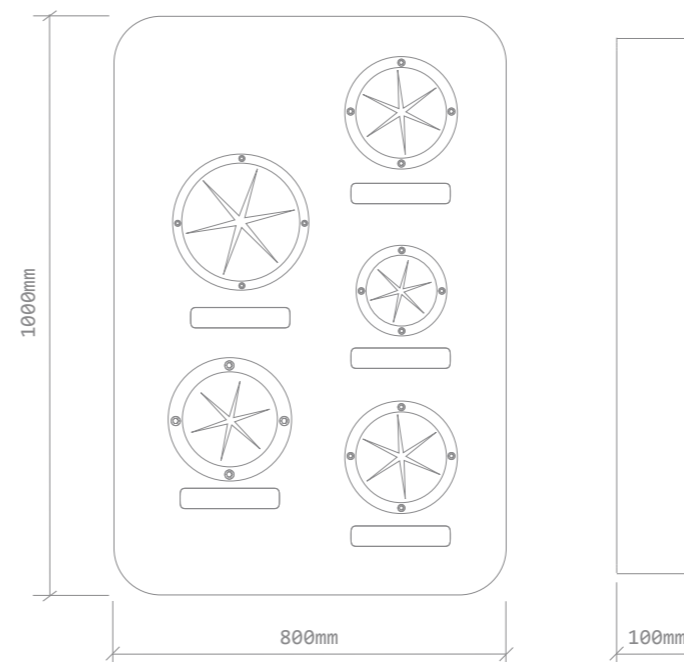

GUESS BOX

This game was developed for Castorama in order to improve the experience of shopping with children. In line with their activity, this play panel brings a new perspective to trusting your senses. Put your hands inside the different holes and guess what is inside! Don't be shy have a try...

DEVELOPMENTAL BENEFITS

Curiosity
Dexterity
Memory
Motor Skills
Senses

AGE RANGE

3-10

FEATURES

Ergonomically-designed for ease of use
Made to be upgraded when you want
Visually attractive to encourage creativity
Easy cleaning

DETAILS

MEMORY GAME

This game was developed for Castorama in order to improve the experience of shopping with children. In line with their activity, this play panel is a remix of the famous memory game. The goal is to find all the pairs related with the store products in the given time. Pay attention to the timer!

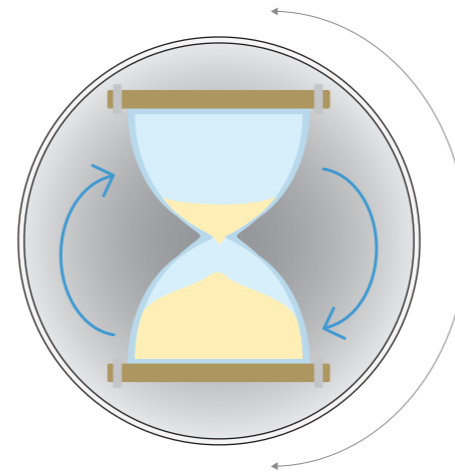

FRONT / SIDE VIEW

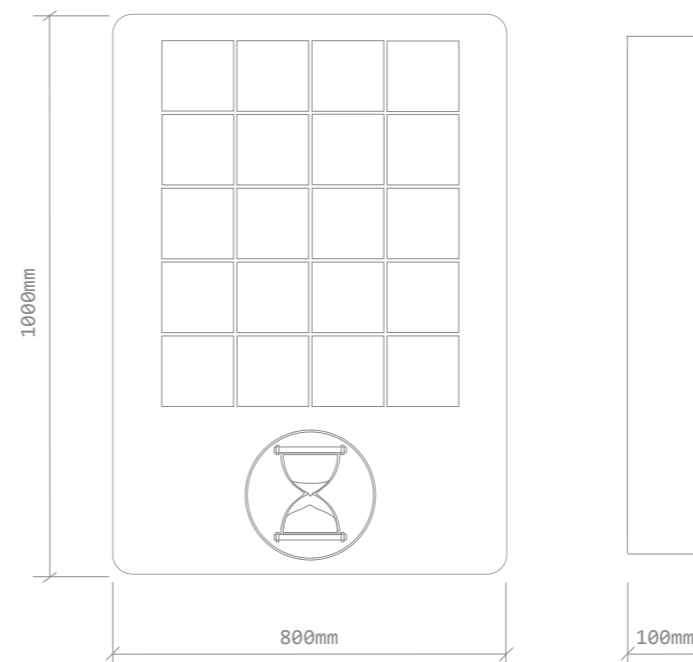

DEVELOPMENTAL BENEFITS

Agility
Logic
Dexterity
Concentration
Motor Skills

AGE RANGE

3-10

FEATURES

Ergonomically-designed for ease of use
Made to improve matching and logical skills
Visually attractive to encourage creativity
Easy cleaning



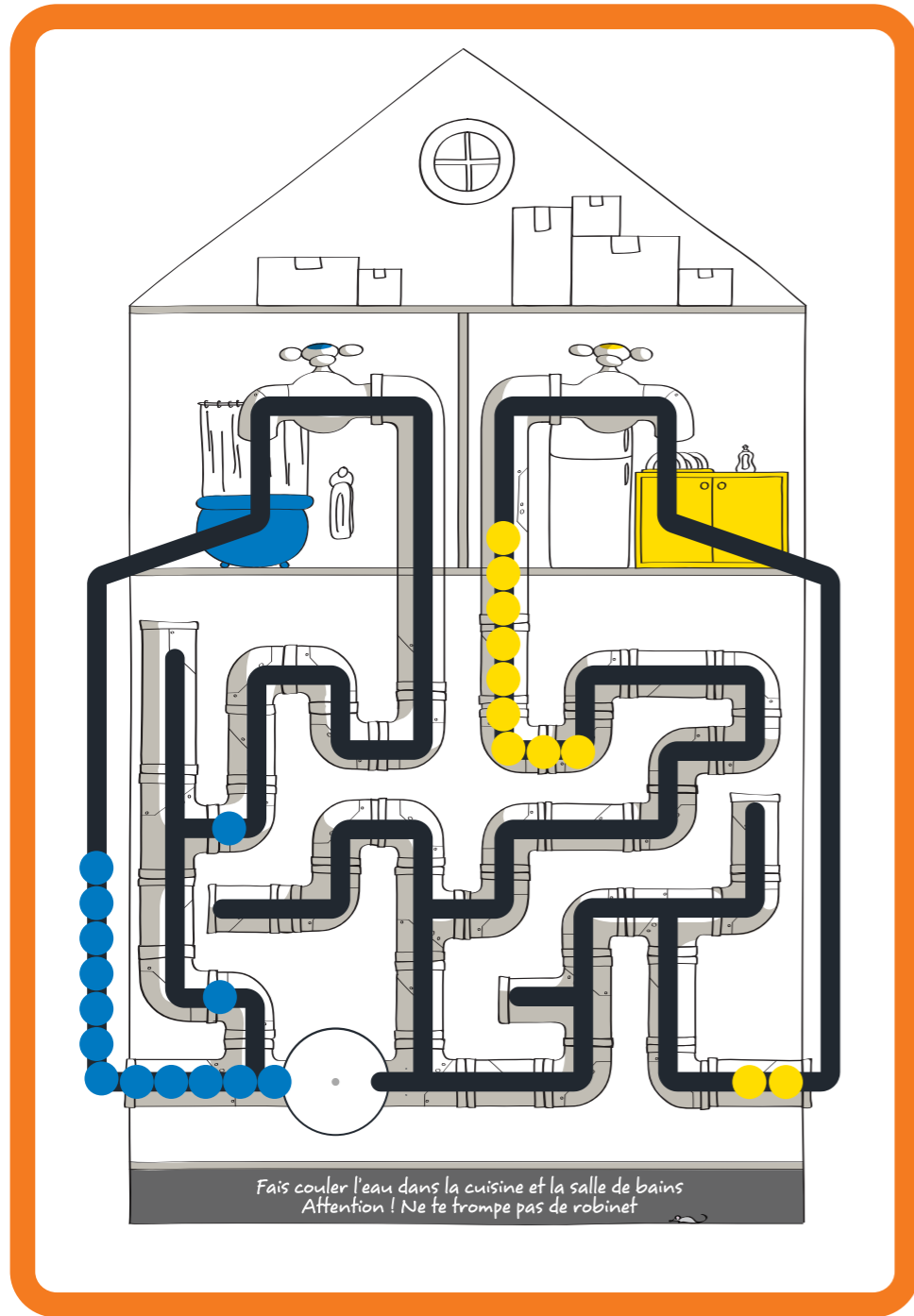

DETAILS



LABYRINTH

This game was developed for Castorama in order to improve the experience of shopping with children. This play panel enables the children to develop their motor skills. The objective is to make the water run from the kitchen and bathroom (here represented by the blue and yellow balls) without mixing them.

FRONT / SIDE VIEW

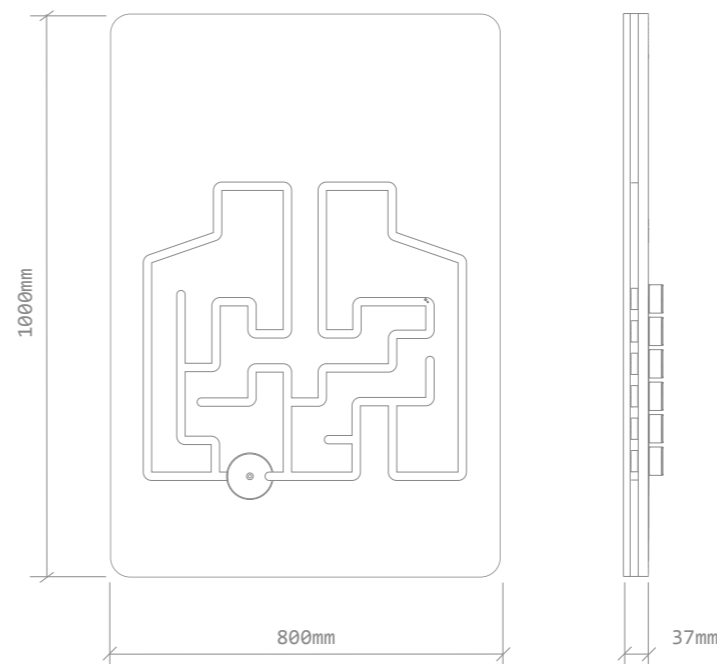

DEVELOPMENTAL BENEFITS

Agility
Dexterity
Motor Skills

AGE RANGE

3-10

FEATURES

Ergonomically-designed for ease of use
Made to improve matching and analytics skills
Visually attractive to encourage creativity
Easy cleaning

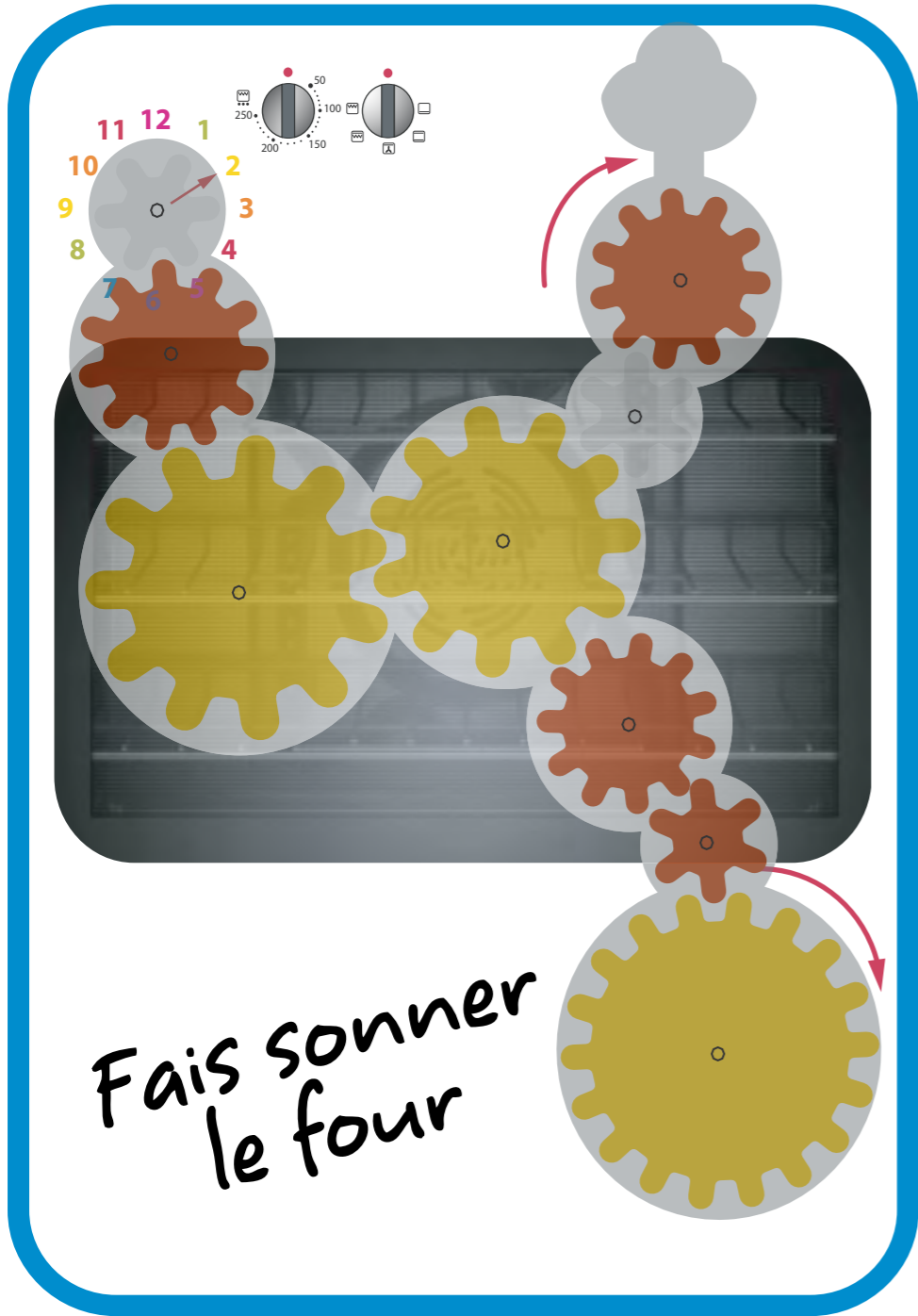

DETAILS

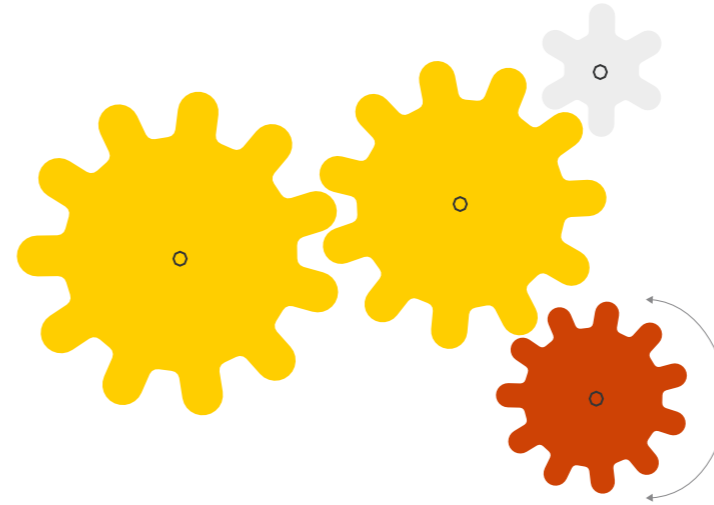

OVEN

This activity is designed to awaken the senses of children while playing. Rotate the handles until the bell sounds ... dinner is ready.

FRONT / SIDE VIEW

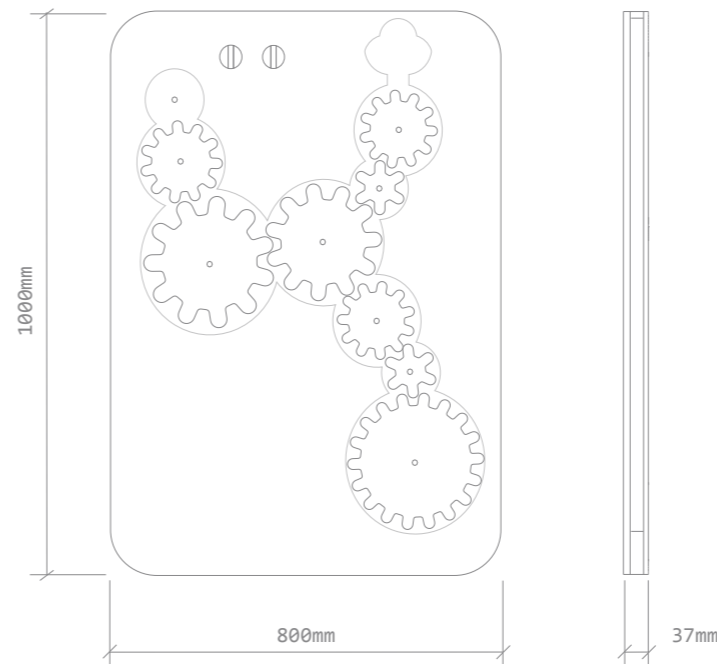

DEVELOPMENTAL BENEFITS

Agility
Dexterity
Motor Skills
Senses

AGE RANGE

3-10

FEATURES

Ergonomically-designed for ease of use
Visually attractive to encourage creativity
Easy cleaning

REFERENCES





CONTACT

BOULEVARD GÉNÉRAL WAHIS 16EB - 1030 BRUSSELS - BELGIUM
UL. PRZEMYSTOWA 2 - KOSTRZYN ODRA - POLAND
Telf: +32 027 054 353

WWW.L-BEE.COM