

# Phytochemistry and pharmacogenomics of natural products derived from traditional chinese medicine and chinese materia medica with activity against tumor cells

Thomas Efferth,<sup>1</sup> Stefan Kahl,<sup>2,3,6</sup> Kerstin Paulus,<sup>4</sup> Michael Adams,<sup>2</sup> Rolf Rauh,<sup>5</sup> Herbert Boechzelt,<sup>3</sup> Xiaojiang Hao,<sup>6</sup> Bernd Kaina,<sup>5</sup> and Rudolf Bauer<sup>2</sup>

<sup>1</sup>German Cancer Research Centre, Pharmaceutical Biology, Heidelberg, Germany; <sup>2</sup>Institute of Pharmaceutical Sciences, University of Graz; <sup>3</sup>Joanneum Research, Graz, Austria; <sup>4</sup>Institute of Pharmaceutical Biology, University of Düsseldorf, Düsseldorf, Germany; <sup>5</sup>Institute of Toxicology, University of Mainz, Mainz, Germany; and <sup>6</sup>State Key Laboratory of Phytochemistry and Plant Resources in West China, Kunming Institute of Botany, Chinese Academy of Sciences, Kunming, China

## Abstract

The cure from cancer is still not a reality for all patients, which is mainly due to the limitations of chemotherapy (e.g., drug resistance and toxicity). Apart from the high-throughput screening of synthetic chemical libraries, natural products represent attractive alternatives for drug development. We have done a systematic bioactivity-based screening of natural products derived from medicinal plants used in traditional Chinese medicine. Plant extracts with growth-inhibitory activity against tumor cells have been fractionated by chromatographic techniques. We have isolated the bioactive compounds and elucidated the chemical structures by nuclear magnetic resonance and mass spectrometry. By this strategy, we identified 25-*O*-acetyl-23,24-dihydro-cucurbitacin F as a cytotoxic constituent of *Quisqualis indica*. Another promising compound identified by this approach was miltirone from *Salvia miltiorrhiza*. The IC<sub>50</sub> values for miltirone of 60 National Cancer Institute cell lines were associated with the microarray-based expression of 9,706 genes. By COMPARE and hierarchical cluster analyses, candidate genes were identified, which significantly predicted sensitivity or resistance of cell lines to miltirone. [Mol Cancer Ther 2008; 7(1):152–61]

Received 1/31/07; revised 9/21/07; accepted 12/4/07.

Grant support: Joanneum Research, Graz, Austria (S. Kahl).

The costs of publication of this article were defrayed in part by the payment of page charges. This article must therefore be hereby marked advertisement in accordance with 18 U.S.C. Section 1734 solely to indicate this fact.

Requests for reprints: Thomas Efferth, German Cancer Research Centre, Pharmaceutical Biology (C015), Im Neuenheimer Feld 280, 69120 Heidelberg, Germany. Phone: 49-6221-423426; Fax: 49-6221-423433. E-mail: t.efferth@dkfz.de

Copyright © 2008 American Association for Cancer Research.

doi:10.1158/1535-7163.MCT-07-0073

## Introduction

Cancer is responsible for 12% of the world's mortality and the second-leading cause of death in the Western world. Limited chances for cure by chemotherapy are a major contributing factor to this situation. Despite much progress in recent years, a key problem in tumor therapy with established cytostatic compounds is the development of drug resistance and threatening side effects. Most established drugs suffer from insufficient specificity toward tumor cells. Hence, the identification of improved anti-tumor drugs is urgently needed.

Several approaches have been delineated to search for novel antitumor compounds. Combinatorial chemistry, a technology conceived about 20 years ago, was envisaged as a promising strategy to this demand. The expected surge in productivity, however, has hardly materialized (1).

Other sources are natural products. Marine and terrestrial plants and animals are a fertile ground to find novel drugs. Prominent examples for the success of natural products originally obtained from plants are the *Vinca* alkaloids from *Catharanthus roseus* G. Don. (Apocynaceae), the DNA topoisomerase I inhibitor camptothecin from *Camptotheca acuminata* Decne. (Nyssaceae), the terpene paclitaxel from *Taxus brevifolia* Nutt. (Taxaceae), or the lignan podophyllotoxin isolated from *Podophyllum peltatum* L. (Berberidaceae; ref. 2).

Evidently, 69% of anticancer drugs approved between the 1980s and 2002 are either natural products or developed based on knowledge gained from natural products (1). Arguably, about three quarters of plant-derived drugs in clinical use today came to the attention of pharmaceutical companies because of their use in traditional medicines (3). The long-lasting experience of traditional folk medicines may facilitate the identification of novel agents. Although in industrialized countries medicinal herbs gradually lost importance in the course of chemistry's progress during the 20th century, bioactive plant constituents are recently experiencing an impressive revival (4). Most of these potentially useful plant products are products of secondary metabolic pathways and serve their producers either as protective agents against herbivores and various pathogens or as growth regulators. Due to these physiologic functions, secondary metabolites could be potential anticancer drugs. It is estimated that only 25,000 plant species have been studied exhaustively for possible medical applications. This is a minor fraction of the approximate total of 250,000 to 300,000 higher plant species in the world (3).

These facts lead us to pursue the search for new bioactive lead structures with antitumor activity by a strategy of

bioactivity-guided isolation from plants used in traditional folk medicines. Medicinal plants used in many tribes all worldwide are studied in ethnobotany and ethnopharmacology (5). It can be expected that the search for bioactive plant compounds is more successful in medicinal plants than a search across all plant species. Traditional Chinese medicine commands a unique position among traditional medicines because its enormous variety of drugs of plant origin is founded on more than 5,000 years of tradition. An elaborated system has been developed and many written documents and textbooks have been handed down over the millennia. This might imply that inactive plants and recipes have vanished over the centuries and that the materia medica of modern traditional Chinese medicine is enriched with bioactive plants. This may improve prospects for identifying novel active constituents from traditional Chinese medicine significantly (6). Based on this rationale, we started the systematic isolation of chemical compounds from medicinal plants used in traditional Chinese medicine and their biological and pharmacologic characterization.

## Materials and Methods

### Collection of Medicinal Plants in the Yunnan Province

Seventy-six medicinal plants were collected in China. Some samples were from Menglun county, prefecture Xishuangbanna, in Yunnan province located at 600 to 700 m above sea level. The botanical identification was done by Prof. Chen Yu, Prof. Tao Guo Da, Prof. Tao De Ding, and Chen Jia Hui. Voucher specimens are deposited at the herbarium of the Institute of Plant Sciences, University of Graz, Graz, Austria (Herbar GZU). Other samples were purchased at the medicinal plant market in Kunming, Yunnan province.

The finely ground plant material was successively extracted with solvents of increasing polarity [petroleum ether (or *n*-hexane), ethyl acetate, and methanol]. Organic solvent extracts were made in a Soxhlet apparatus, whereas water extracts were made as decoctions according to the traditional medicinal preparation. The aim of this approach was to divide plant constituents into fractions of different polarity on extraction. Had only water decocts been made, both low- and high-polarity substances would have been extracted together and only chromatographic separation and retesting for bioactivity would have yielded more information on potential bioactive constituents.

### Chromatographic Techniques

Analytic TLC was done with silica gel glass plates (5 × 10 cm) as stationary phase (Qingdao Haiyang Co.) and petrol ether, chloroform, ethyl acetate, ethanol, or methanol as solvents for the mobile phases. Pigments visible at daylight were documented by photographing. Then, the plates were observed under UV light and stained with iodine and photographed. The plates were then immersed in 10% ethanol sulfuric acid, slowly heated, and photographed again.

For column chromatography, silica gel (grit size 200–300 mesh; Qingdao Haiyang) or Sephadex LH-20 (Amersham

Biosciences) was used to fill glass columns. The fractions obtained were evaporated using a rotavapor system (RE-111; Büchi).

For medium-pressure liquid chromatography, we used 56-cm columns (ø 1.9 cm; Büchi), separation material RP-18 (14–63 μm; Merck), and a rotavapor (RE-111).

High-pressure liquid chromatography was done using an Agilent 1100 Series with autosampler G1313A (Agilent Technologies) and photodiode array detector (Agilent Technologies) run with HP Chemstation (Hewlett-Packard). The columns used were XTerra Prep 7.8 × 150 mm and 19 × 150 mm (Waters). RP-10 (10 μm) served as separation material. The flow rates were 1 mL/min for analytic high-pressure liquid chromatography and 10 mL/min for semi-preparative high-pressure liquid chromatography. Detection was done at wavelength of 210, 230, 254, 280, and 312 nm. The column temperature was 30°C.

### Spectrometric Methods

Nuclear magnetic resonance spectra (<sup>1</sup>H, <sup>13</sup>C, COSY, HMQC, HSQC, HMBC, and DEPT) were recorded at 295K with tetramethylsilane as internal standard by means of an AM-400 MHz spectrometer (Bruker Analytical GmbH) for <sup>1</sup>H and <sup>13</sup>C spectra and by means of an DRX-500 MHz spectrometer (Bruker Analytical GmbH) for two-dimensional spectra. Solvents were obtained from Cambridge Isotope Laboratories. A Finnigan-4510 mass spectrometer was used for the measurement of electron ionizing and fast atom bombardment mass spectra and an API QSTAR Pulsar I mass spectrometer for determination of time-of-flight mass spectra. Glycerine served as a matrix.

### Crystal Structure Analysis

The analysis of crystal structures was done at the Institute of Chemistry (University of Graz; head: Prof. Ferdinand Belaj). All measurements were done with graphite-monochromatized MoK<sub>α</sub> radiation. A total of 3,970 reflexions were measured (Θ<sub>max</sub> = 26.0°), of which 3,132 were symmetry independent ( $R_{\text{int}} = 0.0182$ ) with 2,937, which showed  $I > 2\sigma(I)$ . Structures were elucidated with direct methods (SHELXS-97) and refined with full matrix least squares techniques against  $F^2$  (SHELXL-97; refs. 7, 8). The detection of nonhydrogen atoms was improved with anisotropic displacement variables. For the detection of hydrogen atoms of the same methyl group and with idealized geometry (C-H distance of 0.98 Å), hydrogen atoms with common isotropic displacement variables were used. The absence of heavy elements obviated the determination of absolute structures of chiral centers from structural data. Because triterpenes always exhibit an 8S configuration, the configuration of all other chiral centers could be reconciled. For 374 variables, final R indices of  $R = 0.0363$  and  $wR^2 = 0.0949$  (GOF = 1.022) were obtained. The biggest peak of a difference Fourier map was  $0.624 \text{ e}\text{\AA}^{-3}$ .

### Cell Lines

Human CCRF-CEM leukemia cells were maintained in RPMI 1640 (Life Technologies) supplemented with 10% FCS in a humidified 7% CO<sub>2</sub> atmosphere at 37°C. Cells were passaged twice weekly. All experiments were done

with cells in the logarithmic growth phase. The multidrug resistance gene 1-expressing (*ABCB1*, *MDR1*) CEM/ADR5000 subline was maintained in 5,000 ng/mL doxorubicin. The establishment of the resistant subline has been described (9).

The panel of 60 human tumor cell lines of the Developmental Therapeutics Program of the National Cancer Institute (NCI) consisted of leukemia, melanoma, and non-small cell lung cancer cell lines, cancer cells of the colon, kidney, ovary, breast, or prostate, and cells of tumors of the central nervous system. Their origin and processing have been previously described (10).

#### Sulforhodamine B Assay

The determination of drug sensitivity in the NCI cell lines by the sulforhodamine B assay has been reported (11). The inhibition concentration 50% ( $IC_{50}$ ) values for miltirone and other anticancer drugs have been deposited in the database of the NCI database.<sup>7</sup>

#### Growth Inhibition Assay

The *in vitro* response to drugs was evaluated by means of a growth inhibition assay as described (12). Aliquots of  $5 \times 10^4$  cells/mL were seeded in 24-well plates, and plant extracts, fractions, or isolated pure compounds were added. Extracts and fractions were tested at a fixed concentration of 10  $\mu$ g/mL, whereas isolated compounds were used in different doses to allow calculation of  $IC_{50}$  values. Cells were counted 7 days after treatment with the drugs. The resulting growth data represent the net outcome of cell proliferation and cell death.

#### Antifungal Testing

Antifungal testing was done by using the UC-4376 strain of *Penicillium avellaneum*. Culture medium [0.5 g  $KH_2PO_4$ , 7.8 g  $Na_2HPO_4 \times 12 H_2O$ , 5 g yeast extract, 10 g glucose, and 15 g agar and 1 L water (pH 7.1)] was sterilized, inoculated with fungal spores, and spilled in Petri dishes. First, a solution of 1 mg plant extract was dispersed on a paper disc and the solvent was evaporated. Then, the paper disc was lightly pressed on the agar plate. After incubation for 24 to 48 h at 42°C, the zones of inhibition were measured. Positive tests were repeated with different extract amounts (20  $\mu$ g, 100  $\mu$ g, 200  $\mu$ g, 1 mg, and 2 mg) to obtain dose-response curves.

#### Statistical Analyses

COMPARE analyses enable rank-ordered lists of cytotoxic compounds tested in the NCI cell lines. The methodology has previously been described in detail (13). Briefly, every set of  $IC_{50}$  values of an investigational compound in the panel of NCI cell lines is ranked for similarity to the  $IC_{50}$  values for other compounds. COMPARE analyses were also done with genome-wide mRNA expression values of the 60 NCI cell lines. The mRNA expression has been determined by microarray analyses (14–16). The mRNA expression values were taken from the NCI database.<sup>7</sup>

Kendall's  $\tau$  test was used to calculate significance values and rank correlation coefficients as a relative measure for the linear dependency of two variables. This test was implemented into the WinSTAT Program (Kalmia).

## Results

### Selection of Plant Species for Investigation

A crucial step in our investigations was the selection of potential plant candidates for extraction and isolation of bioactive constituents. One challenge was presented by the fact that the definition of the term "tumor" is different between traditional Chinese medicine and Western medicine. We, therefore, extended our search to include not only various kinds of tumors (cancer, adenoma, and carcinoids) but also swellings. However, no immune-stimulating plants were included. It is estimated that 700 to 800 plants are used in China for the treatment of cancer and cancer-related syndromes (17).

The most important source of potentially useful plants was traditional Chinese medicine (Chinese: *zhongyao*), as it is recorded in the current Chinese pharmacopoeia. In addition, plants from Chinese herbal folk medicine (Chinese: *zhongcaoyao*) were included. *Zhongcaoyao* is in regionally variable folk use and not yet incorporated into the national pharmacopoeia.

The compiled list of plants, therefore, included species at all possible steps in the evolutionary ladder of *materia medica*: plants in folkloristic use with anecdotal evidence for effectiveness; Chinese medicine with no *in vitro*, *in vivo*, or clinical evidence; and Chinese medicine with which *in vitro*, *in vivo*, or clinical studies have been conducted, but no active principle was known, plus the few species where active constituents with antitumor activity already have been isolated.

The collected data were compiled into a database that currently includes 561 species<sup>8</sup> listing Latin and Chinese names in Chinese characters and Pinyin transcription. Furthermore, it is recorded which parts of the plant are in medicinal use, references to studies, and data about harvest and processing of the plant material are included.

### Bioactivity Screening of Plant Extracts

As a next step, extracts from 76 medicinal plants included in our database were analyzed for their activity to inhibit the growth of tumor cells. Of 253 extracts, 23 extracts (9%) from 18 different plant species reduced cell growth of human CCRF-CEM leukemia cells below 20% of untreated controls at a test concentration of 10  $\mu$ g/mL. Hence, 24% of all plants analyzed showed considerable activity against CCRF-CEM cells. An overview of the results of extract screening is shown in Fig. 1. Among others, the bioactive extracts were from the plants *Salvia miltiorrhiza* Bunge (Lamiaceae), *Lonicera japonica* Thunb. (Caprifoliaceae), *Eleutherococcus senticosus* Maxim

<sup>7</sup> <http://dtp.nci.nih.gov>

<sup>8</sup> <http://www.chinese.botanicals.at>

**Figure 1.** Screening of 253 extracts from Chinese medicinal plants. *Light gray bars*, growth inhibition of CCRF-CEM leukemia cells by plant extracts (concentration: 10  $\mu\text{g}/\text{mL}$ ; *low bars*, high activity). *Dark gray bars*, antifungal activity of extracts (*high bars*, high activity).

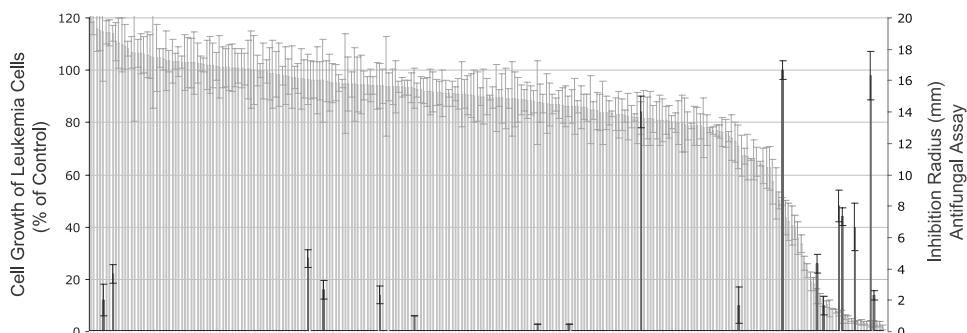

(Araliaceae), *Hydnocarpus anthelmintica* Gaertner (Flacourtiaceae), *Curcuma longa* L. (Zingiberaceae), *Caesalpinia sappan* L. (Caesalpinaceae), and *Quisqualis indica* L. (Combretaceae).

Among the 253 extracts were 16 *n*-hexane, 64 petroleum ether, 13 ethyl acetate, 80 methanol, and 80 water extracts. Among the *n*-hexane/petroleum ether extracts (which we can subsume as the low-polarity fraction), 11 were active (corresponding to 13.8% of low-polarity extracts), whereas 5 ethyl acetate extracts (corresponding to 38.5% of medium-polarity extracts) were active and 7 methanol extracts (8.8% of high-polarity extracts).

In addition to the screening for bioactivity against leukemia cells, we also did antifungal testing using the UC-4376 strain of *P. avellaneum*. Of 253 extracts, 18 were active. The active extracts were from 16 plant species (21%). Among the extracts with activity in the antifungal assay, 14 were petrol ether extracts, 3 were methanol extracts, and 1 was water extract. Hence, 78% of all active extracts were rather apolar petrol ether extracts. Furthermore, compounds with activity against leukemia cells were significantly more active against fungi than inactive ones. Of 23 extracts active against leukemia cells, 7 were also active against fungi (30%), whereas only 11 extracts (5%) showed bioactivity against fungi, which were inactive toward tumor cells ( $P = 5.04 \times 10^{-6}$ , Fisher's exact test), indicating that some extracts contain generally cytotoxic compounds (i.e., petroleum ether extracts of *Saussurea lappa* or methanol extracts of *Cocculus trilobus*).

#### Isolation of Chemically Characterized Natural Products

Extracts that showed activity against CCRF-CEM leukemia cells were further fractionated by means of column chromatography or medium-pressure liquid chromatography, high-pressure liquid chromatography, or gel permeation chromatography (Sephadex LH-20). Then, all fractions were tested again using the leukemia cell growth inhibition assay. The most active fractions were then used for further fractionation steps. This procedure finally led to the isolation of pure compounds. An example of this procedure from the raw extracts to the isolation of pure compounds is shown in Fig. 2. The chemical structures of the compounds isolated from *Q. indica* have been established by means of nuclear magnetic resonance spectroscopy and mass spectroscopy. They were identified as

arjunolic acid (1), kaempferol-3-*O*- $\beta$ -D-glucopyranoside (2), 3-*O*-[6'-*O*-palmitoyl- $\beta$ -D-glucosyl]-stigma-sta-5,25(27)-diene (3), kaempferol (4), 25-*O*-acetyl-23,24-dihydrocucurbitacin F (5), 23,24-dihydrocucurbitacin F (6), and 3-*O*- $\beta$ -D-glucosyl-stigmasta-5,25(27)-diene (7).

The *in vitro* response of tumor cells to these compounds was measured by means of a cell growth inhibition assay. Three of seven isolated compounds (compounds 4–6) inhibited the cell growth of CCRF-CEM leukemia cells (Fig. 3). The other compounds were inactive.

#### Activity of *S. miltiorrhiza* Compounds and Cross-Resistance Profile

The *n*-hexane extract of the roots of *S. miltiorrhiza* was highly active in the leukemia assay. After testing a panel of different compounds isolated from *S. miltiorrhiza* (18), we observed that the compounds miltirone, tanshinone I, and tanshinone IIa are responsible for this effect (Fig. 4). To test these three compounds in more detail, we have treated sensitive CCRF-CEM parental cells and the P-glycoprotein/*MDR1* overexpressing subline, CEM/ADR5000, with miltirone, tanshinone I, and tanshinone IIa, respectively, and compared the response rates obtained with those of established cytostatic drugs. Although the multidrug-resistant CEM/ADR5000 cells exhibited high levels of resistance to DNA topoisomerase II inhibitors (doxorubicin, etoposide, and teniposide) and mitotic spindle inhibitors (vincristine, paclitaxel, and docetaxel), no or only minimal cross-resistance was observed to the three compounds derived from *S. miltiorrhiza* as well as to the antimetabolite methotrexate (Table 1). Because the 50% inhibition concentrations ( $\text{IC}_{50}$ ) for miltirone were lower than that for the tanshinones, we decided to focus our efforts on miltirone in subsequent investigations.

#### Pharmacogenomics

We did COMPARE analyses of the  $\text{IC}_{50}$  values for miltirone and the mRNA expression of 9,706 genes of the NCI cell lines to produce scale indices of correlation coefficients. We did a standard COMPARE analysis in which cell lines most inhibited by miltirone (lowest  $\text{IC}_{50}$  values) were correlated with the lowest mRNA expression levels of genes. As shown in Table 2, two genes with a correlation coefficient of  $R > 0.6$  were identified by this approach, *SMARCC1* and a novel, still not further specified gene. These genes may be considered possible candidate genes, which determine cellular resistance to miltirone.

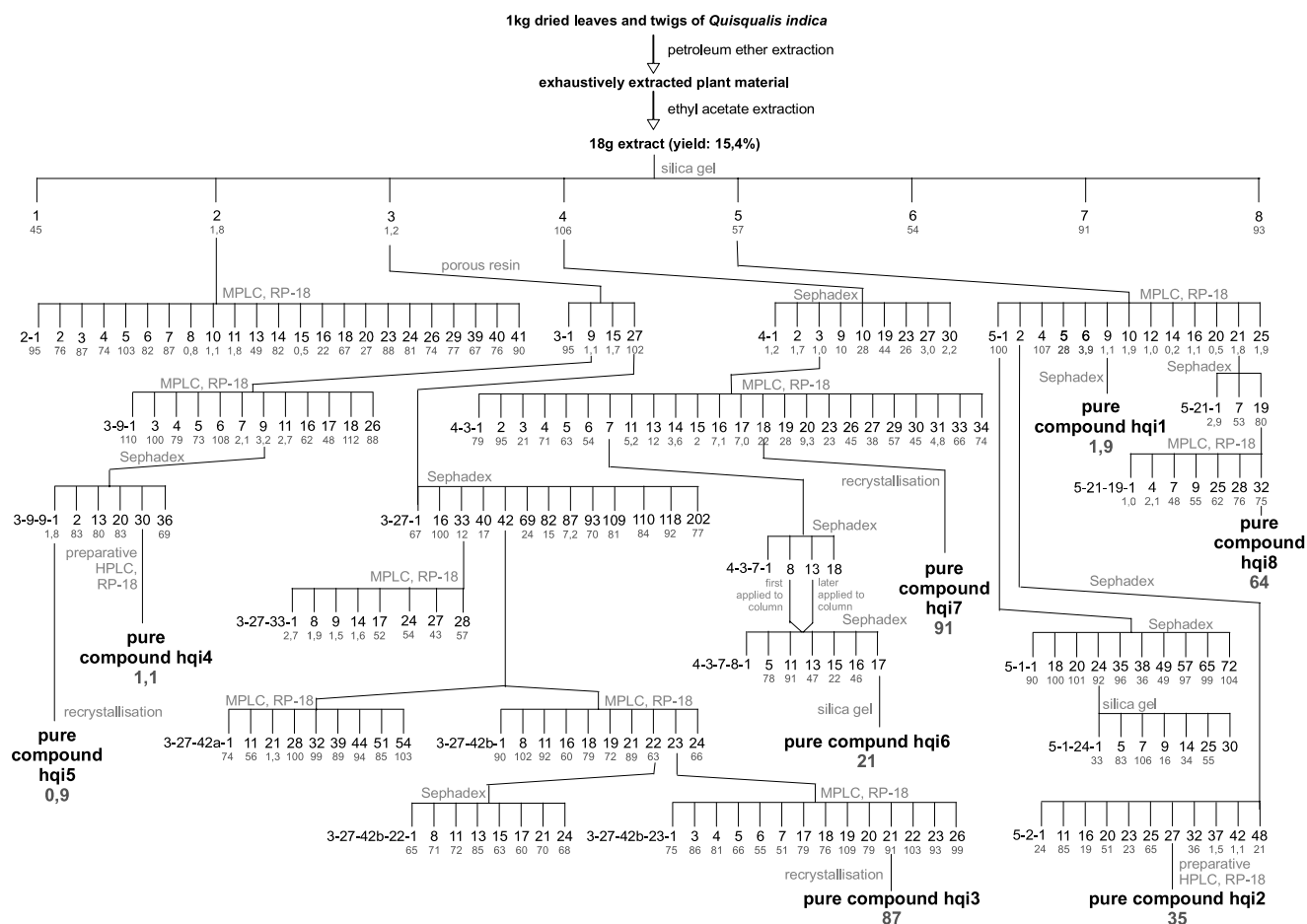

**Figure 2.** Bioactivity-guided screening of compounds from *Q. indica* L. (34). *Black numbers*, fraction numbers; *gray numbers*, cell growth (%) of treated CCRF-CEM leukemia cells treated with 10 µg/mL of extracts compared with untreated controls in the cell growth inhibition assay. Leaves and twigs of *Q. indica* were first defatted with petroleum ether and then extracted exhaustively with ethyl acetate. The crude extract was immediately subjected to a silica gel column. The eluted fractions were further fractionated by column chromatography and medium-pressure liquid chromatography (MPLC) using normal- and reversed-phase silica gel or Sephadex LH-20 as well as high-pressure liquid chromatography (HPLC). Because of the large geographic distance between the phytochemistry laboratory (China) and the pharmacologic testing laboratory (Germany), it was not possible to test all fractions after each fractionation step. Therefore, about 100 fractions had to be produced in several fractionation steps and were tested together. The activity pattern among the fractions decided the direction of further work. Seven pure compounds were isolated. Among them are two cucurbitane triterpenes (25-*O*-acetyl-23,24-dihydrocucurbitacin F and 23,24-dihydrocucurbitacin F), two flavonoids (kaempferol and kaempferol-3-*O*-β-D-glucopyranoside), one pentacyclic triterpene (arjunolic acid), and two sterols [3-*O*-β-D-glucosyl-stigmasta-5,25(27)-diene and 3-*O*-[6'-*O*-palmitoyl-β-D-glucosyl]-stigmasta-5,25(27)-diene]. The structures of these compounds were elucidated with spectroscopic methods (mass spectrometry and nuclear magnetic resonance) and X-ray diffraction analysis. 25-*O*-Acetyl-23,24-dihydrocucurbitacin F showed the strongest activity in the leukemia assay followed by 23,24-dihydrocucurbitacin F and kaempferol. Furthermore, arjunolic acid had moderate activity but yielded inconsistent test results. Because the amount of 25-*O*-acetyl-23,24-dihydrocucurbitacin F contained in *Q. indica* is very high, this compound can be called the cytotoxic principle of this plant. Kaempferol-3-*O*-β-D-glucopyranoside and the two isolated sterols possess no activity in the leukemia assay.

Furthermore, reverse COMPARE analyses were done, which correlated the most inhibited cell lines with the highest gene expression levels (Table 2). This approach provided the *ALDH3A2* gene that might determine cellular sensitivity to miltirone ( $R < -0.6$ ; Table 2).

*Hierarchical Cluster Analyses.* The genes obtained by standard and reverse COMPARE analyses for miltirone were subjected to hierarchical cluster analysis to obtain a dendrogram, where the cell lines are arranged according to their expression profile of these genes. The dendrogram for miltirone can be divided into five major cluster branches (Fig. 5).

Then, the  $\log_{10}$   $IC_{50}$  values for miltirone were used as a cutoff threshold to define cell lines as being sensitive or resistant. The distribution of sensitive and resistant cell lines was significantly different between the branches of the dendrogram, indicating that cellular response to miltirone was predictable by the mRNA expression of these genes (Table 3).

## Discussion

Over the past years, there was a major shift in the development of cancer drugs from screening of cytotoxic drugs

to the development of molecularly targeted drugs. The conceptual idea is that the knowledge of the mechanism(s) of action of a drug provides a better approach to reach improved clinical results based on patients' molecular characteristics. The complexity of this task requires the interaction of scientists from different fields. This was the starting point of our efforts on the bioactivity-guided screening for natural products derived from medicinal plants of traditional Chinese medicine.

The first step in our bioactivity-guided approach was the screening of 253 extracts from 76 medicinal plants. A considerable growth-inhibitory activity toward CCRF-

CEM leukemia cells was observed with 23 extracts derived from 18 plants. This is a hit rate of 24%. A failure rate of 76% is not as disappointing as it seems at first sight. A recent screening project on the antiproliferative activity of Chinese medicinal herbs on breast cancer cells *in vitro* revealed similar results. Campbell et al. (19) found 15 of 71 active extracts (21%). Hit rates of 20% and above in medicinal plant extract screenings generally are well above the success rates of screenings of large chemical libraries with synthetically synthesized compounds. Nevertheless, it is reasonable to ask why three quarters of medicinal plants tested in our approach were inactive

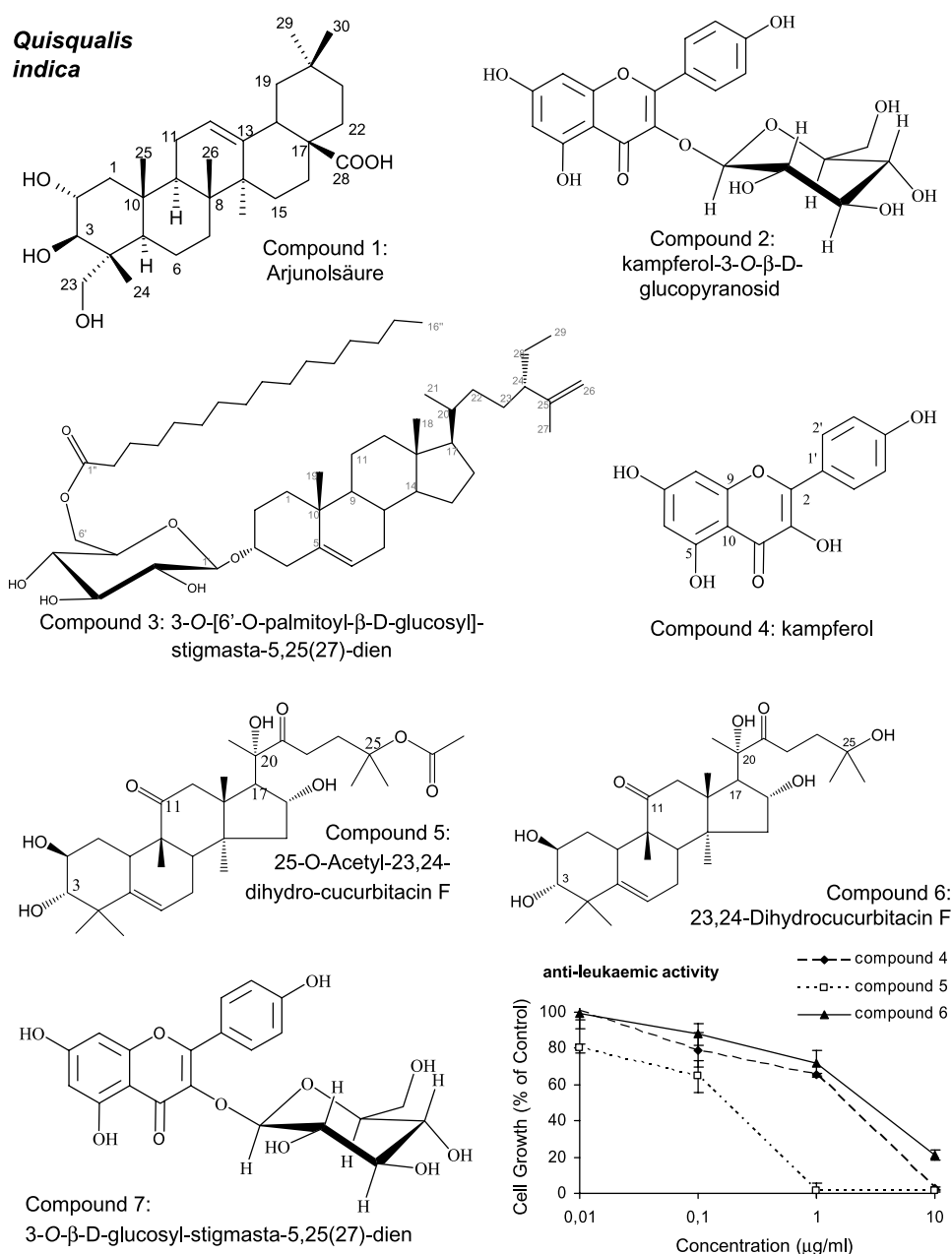

**Figure 3.** Chemical structures and bioactivity of natural products from *Q. indica* L.

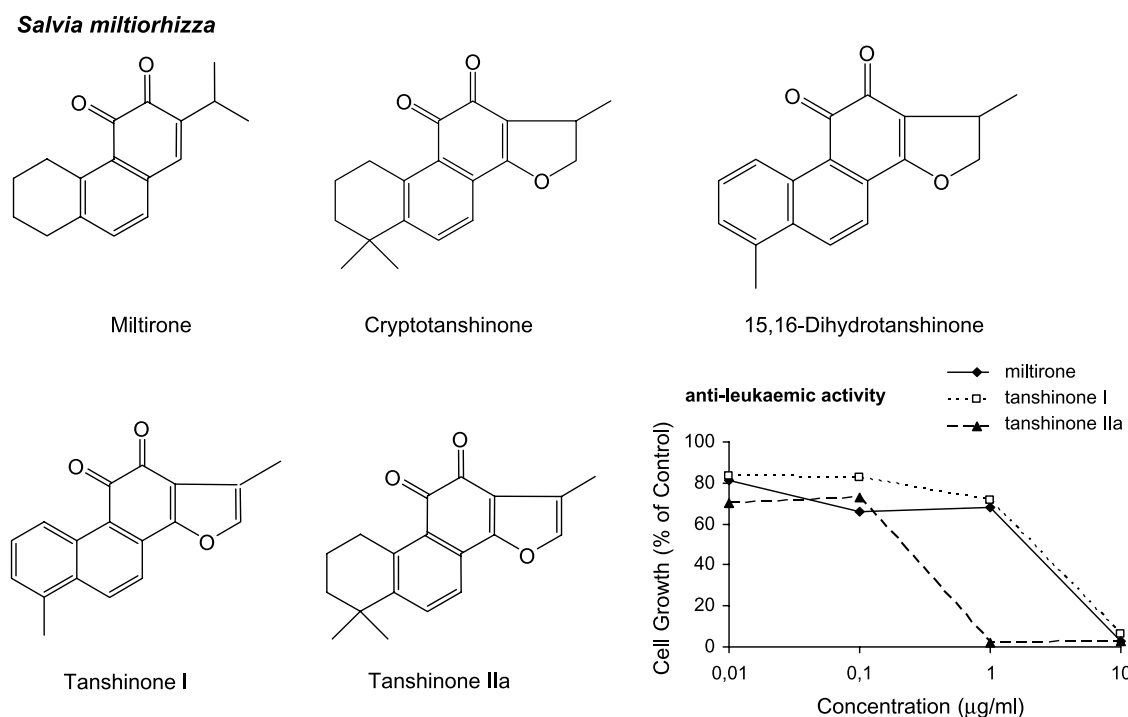

**Figure 4.** Chemical structures and bioactivity of natural products from *S. miltiorrhiza* L.

because they maintained in the pharmacopoeia of traditional Chinese medicine over many centuries. The reason could be that herbal mixtures and composite traditional Chinese medicine remedies (fu-fang) may act in a synergistic fashion to increase therapeutic effects or, on the other hand, may quench side effects on healthy tissues by antagonistic effects. By means of the current methodology of phytochemistry and pharmacology, it is still

difficult to dissect synergistic or antagonistic effects of dozens of chemical constituents of herbal composite prescriptions.

Interestingly, the percentage of active extracts was considerably higher among the ethyl acetate extracts compared with all other extracts. Very nonpolar and very polar compounds may less frequently reveal activity against cancer cells. Probably, the limited solubility in aqueous

**Table 1.** Cross-resistance profile of multidrug-resistant human CEM/ADR5000 leukemia cells to miltirone and established cytostatic drugs

Compound	CCRF-CEM ( $\text{IC}_{50}$ )	CEM/ADR5000 ( $\text{IC}_{50}$ )	Degree of resistance
<i>S. miltiorrhiza</i> compounds			
Miltirone	0.6 ( $\pm 0.2$ ) $\mu\text{mol/L}$	1.0 ( $\pm 0.2$ ) $\mu\text{mol/L}$	1.7
Tanshinone I	5.5 ( $\pm 4.2$ ) $\mu\text{mol/L}$	3.1 ( $\pm 1.5$ ) $\mu\text{mol/L}$	0.6
Tanshinone IIa	5.4 ( $\pm 1.5$ ) $\mu\text{mol/L}$	8.7 ( $\pm 2.5$ ) $\mu\text{mol/L}$	1.6
DNA topoisomerase II inhibitors			
Doxorubicin	11.8 ( $\pm 1.9$ ) nmol/L	12.2 ( $\pm 54.2$ ) nmol/L	1,036
Etoposide	85 ( $\pm 20$ ) nmol/L	1,563 ( $\pm 139$ ) nmol/L	18
Etoposide phosphate	69 ( $\pm 7$ ) nmol/L	748 ( $\pm 90$ ) nmol/L	11
Mitotic spindle inhibitor			
Vincristine	1.7 ( $\pm 0.1$ ) nmol/L	1,043 ( $\pm 145$ ) nmol/L	613
Docetaxel	0.4 ( $\pm 0.1$ ) nmol/L	175 ( $\pm 17$ ) nmol/L	438
Paclitaxel	3.7 ( $\pm 0.4$ ) nmol/L	741 ( $\pm 137$ ) nmol/L	200
Antimetabolites			
Methotrexate	14 ( $\pm 2$ ) nmol/L	10 ( $\pm 2$ ) nmol/L	0.7

NOTE: Dose-response curves obtained by means of a cell growth inhibition assay were used to calculate  $\text{IC}_{50}$  values (mean  $\pm$  SD).

**Table 2. Correlation of constitutive mRNA expression of genes identified by standard or reverse COMPARE analysis with IC<sub>50</sub> values for mitrione of 50 NCI cell lines**

Code	GenBank	Correlation coefficient	Name	Function
SMARCC1	U66615	0.642	SWI/SNF related, matrix associated, actin dependent regulator of chromatin, subfamily c, member 1	Chromatin remodeling
Not specified	AL021366	0.604	Unknown	Unknown
ALDH3A2	AA004841	-0.612	Aldehyde dehydrogenase 3 family, member A2	Oxidation of aliphatic aldehydes to fatty acids, involved in glycolysis and gluconeogenesis

solution is not sufficient to explain this lack of activity because the concentrations used in our leukemia cell assay were rather low. In proportion, compounds of low polarity contain fewer functional groups (i.e., oxygen-containing groups) than those of high polarity. Hence, they

tend to be less reactive. This may reduce the chances to find bioactive molecules. Structural variety increases with increasing polarity. This could in turn enhance the probability for occurrence of bioactive substances. Indeed, many natural products with pharmacologic activity possess

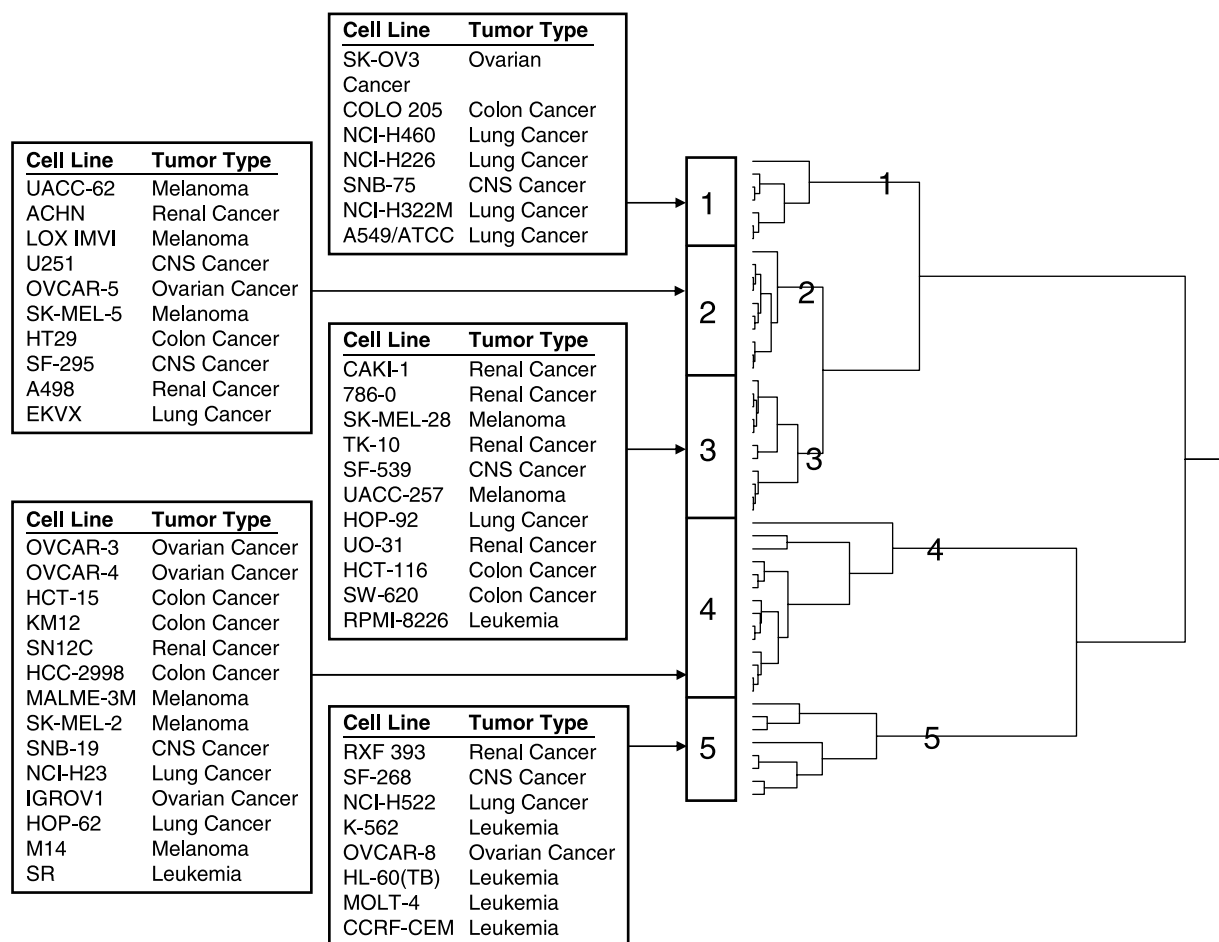

**Figure 5.** Dendrogram of hierarchical cluster analysis (complete linkage method) obtained from mRNA expression of genes correlating with  $\log_{10}$  IC<sub>50</sub> values for mitrione (see Table 2). The dendrogram shows the clustering of 50 cell lines of the NCI's screening panel and the distribution of the cell lines according to their responsiveness to mitrione. The median  $\log_{10}$  IC<sub>50</sub> values for mitrione were used as a cutoff to separate tumor cell lines as being "sensitive" or "resistant."



polar functional groups. A high structural diversity of compounds can be expected in extracts of higher polarity (e.g., methanol or water extracts). They contain partly condensed polyphenols, saponins, and polysaccharides. Despite the structural diversity, the chemical and physical features of many of these compounds are quite similar. Furthermore, sugars and polysaccharides exert rather immunologic than cytotoxic or growth-inhibitory effects. They would have to cross the lipid bilayer of the cell membrane to exert cytotoxicity. This is difficult because of their high polarity. We did not find water extracts with activity against CCRF-CEM leukemia cells. This can be explained by the fact that the extraction of the plant material took place with solvents of low polarity before aqueous decocts were generated. Our results indicate that the search for bioactive molecules may be most promising in extract partitions of middle polarity. Ethyl acetate extracts are of special interest in this context.

As an add-on, we also analyzed the antifungal activity of the plant extracts. The lower rate of activity compared with the leukemia cell assay could be explained by the fact that the present set of medicinal plants has been chosen because of their use in traditional Chinese medicine to treat cancer but not to treat infectious diseases. These results can be taken as a hint for the anticancer-specific activity of the selected plants without broad-spectrum toxicity against many organisms.

As a next step, we started the isolation of natural products from active plant extracts. They were fractionated, and fractions with activity against leukemia cells were further fractionated. This procedure was repeated until the compounds responsible for the bioactivity were isolated and chemically characterized. Using this approach, natural products of two plants (*Q. indica* and *S. miltiorrhiza*) were isolated, whereas the other plants are still under investigation.

Interestingly, the main use of *Q. indica* and *S. miltiorrhiza* in traditional Chinese medicine is not cancer treatment (20). *Q. indica* (Chinese: shihchimtze) is used in traditional Chinese medicine as an anthelmintic plant. *S. miltiorrhiza* (Chinese: danshen) is officially listed in the Chinese pharmacopoeia to treat heart diseases, inflammation, and menstrual disorders. This represents an example that the full therapeutic range of medicinal plants is still not completely explored yet and that further indications, such as cancer treatment, might be promising. The compounds identified in our investigation have been reported previ-

ously to inhibit cancer cells, including drug-resistant cell lines (21–26).

A general problem of modern cancer chemotherapy is the development of drug resistance, especially MDR, which finally prevents the cure of many cancer patients. MDR phenomena are not only responsible for the failure of single drugs but also of treatment regimen with combinations of drugs from different drug classes and different modes of action. The reasons for this broad-spectrum resistance are frequently ATP-binding cassette transporters, which extrude cytostatic drugs out of the cancer cells. The best-analyzed ATP-binding cassette transporter that confers MDR represents P-glycoprotein/*MDR1* (27). Therefore, there is an urgent need for the identification and development of novel compounds with activity against tumors but without involvement in MDR. Our results indicate that the three *S. miltiorrhiza* compounds are not involved in P-glycoprotein-mediated MDR and, hence, might be promising to eradicate otherwise highly multidrug-resistant and multidrug-refractory tumors.

The response of tumor cells to cytotoxic agents is frequently determined by multiple factors (28, 29). For this reason, we have done COMPARE and hierarchical cluster analyses of microarray-based mRNA expression values for 9,706 genes of the NCI cell lines in an effort to gain deeper insight into the multifactorial nature of cellular response to miltirone. We identified three genes from different functional groups (e.g., *SMARCC1*, *ALDH3A2*, and a novel, still not further specified gene). Aldehyde dehydrogenases are known to confer resistance to cyclophosphamide and oxazaphosphorines (30). The other two genes have not been assigned to drug sensitivity yet. *SMARCC1* is involved in the regulation of DNA repair, proliferation, mitosis, and cell cycle arrest, all of which are mechanisms relevant to the determination of cellular response to cytotoxic drugs (31–33). Further studies are warranted to clarify their causative relevance for cellular response to miltirone.

In conclusion, the approach presented here is beneficial when applied to plants rarely or not studied before. The isolation of natural products and the elucidation of their chemical structures enable pharmacologic and molecular biological investigations comparable with chemically synthesized compounds. The identification of target molecules represents the basis for the development of rational treatment strategies for natural products from traditional Chinese medicine.

**Table 3.** Separation of clusters of 50 NCI cell lines obtained by hierarchical cluster analysis shown in Fig. 5 in comparison with miltirone sensitivity

Partition	Clusters 1 and 2	Cluster 4	Clusters 3 and 5	$\chi^2$ test
Sensitive (<−5.247.5 mol/L)*	1	7	17	$P = 3.59 \times 10^{-6}$
Resistant (>−5.247.5 mol/L)*	16	7	2	

\*Log<sub>10</sub> IC<sub>50</sub> value.

## References

1. Newman DJ, Cragg GM. Natural products as sources of new drugs over the last 25 years. *J Nat Prod* 2007;70:461–77.
2. Boik JC. Natural compounds in cancer therapy: promising nontoxic antitumor agents from plants and other natural sources. Princeton: Oregon Medical Press; 2001.
3. Abelson PH. Medicine from plants. *Science* 1990;247:513.
4. Efferth T, Fu YJ, Zu YG, Schwarz G, Konkimalla VS, Wink M. Molecular target-guided tumor therapy with natural products derived from traditional Chinese medicine. *Curr Med Chem* 2007;14:2024–32.
5. Heinrich M, Bremner P. Ethnobotany and ethnopharmacy—their role for anti-cancer drug development. *Curr Drug Targets* 2006;7:239–45.
6. Efferth T, Li PC, Konkimalla VS, Kaina B. From traditional Chinese medicine to rational cancer therapy. *Trends Mol Med* 2007;13:353–61.
7. Sheldrick GM. SHELXS-97. Programm zur Strukturaufklärung. University of Göttingen. Göttingen (Germany); 1997.
8. Sheldrick GM. SADABS, Programm zur Absorptionskorrektur von Bruker (Siemens) Flächenzählerdaten. University of Göttingen. Göttingen (Germany): 1997.
9. Kimmig A, Gekeler V, Neumann M, et al. Susceptibility of multidrug-resistant human leukemia cell lines to human interleukin 2-activated killer cells. *Cancer Res* 1990;50:6793–9.
10. Alley MC, Scudiero DA, Monks A, et al. Feasibility of drug screening with panels of human tumor cell lines using a microculture tetrazolium assay. *Cancer Res* 1988;48:589–601.
11. Rubinstein LV, Shoemaker RH, Paull KD, et al. Comparison of *in vitro* anticancer-drug-screening data generated with a tetrazolium assay versus a protein assay against a diverse panel of human tumor cell lines. *J Natl Cancer Inst* 1990;82:1113–8.
12. Efferth T, Davey M, Olbrich A, Rücker G, Gebhart E, Davey R. Activity of drugs from traditional Chinese medicine toward sensitive and MDR1- or MRP1-overexpressing multidrug-resistant human CCRF-CEM leukemia cells. *Blood Cells Mol Dis* 2002;28:160–8.
13. Wosikowski K, Schuurhuis D, Johnson K, et al. Identification of epidermal growth factor receptor and c-erbB2 pathway inhibitors by correlation with gene expression patterns. *J Natl Cancer Inst* 1997;89:1505–15.
14. Scherf U, Ross DT, Waltham M, et al. A gene expression database for the molecular pharmacology of cancer. *Nat Genet* 2000;24:236–44.
15. Ross DT, Scherf U, Eisen MB, et al. Systematic variation in gene expression patterns in human cancer cell lines. *Nat Genet* 2000;24:227–35.
16. Staunton JE, Slonim DK, Collier HA, et al. Chemosensitivity prediction by transcriptional profiling. *Proc Natl Acad Sci U S A* 2001;98:10787–92.
17. Zhu YP. Chinese materia medica: chemistry, pharmacology and applications. Amsterdam: Harwood Academic Publishers; 1998.
18. Paulus K. Untersuchungen zur Leukotrienbiosynthese-hemmenden Wirkung chinesischer Arzneidrogen, insbesondere von *Salvia miltiorrhiza* radix [dissertation]. Düsseldorf (Germany): University of Düsseldorf; 2002.
19. Campbell MJ, Hamilton B, Shoemaker M, Tagliaferri M, Cohen I, Tripathy D. Antiproliferative activity of Chinese medicinal herbs on breast cancer cells *in vitro*. *Anticancer Res* 2002;22:3843–52.
20. Tang W, Eisenbrand G. Chinese drugs of plant origin. Berlin: Springer; 1992.
21. Li ZT, Yang BJ, Ma GE. Chemical studies of *Salvia miltiorrhiza* f. *alba* [in Chinese]. *Yao Xue Xue Bao* 1991;26:209–13.
22. Wu WL, Chang WL, Chen CF. Cytotoxic activities of tanshinones against human carcinoma cell lines. *Am J Chin Med* 1991;19:207–16.
23. Konoshima T, Takasaki M, Tatsumoto T, et al. Inhibitory effects of cucurbitane triterpenoids on Epstein-Barr virus activation and two-stage carcinogenesis of skin tumors. *Biol Pharm Bull* 1994;17:668–71.
24. Yuan SL, Wang XJ, Wei YQ. Anticancer effect of tanshinone and its mechanisms [in Chinese]. *Ai Zheng* 2003;22:1363–6.
25. Yuan SL, Wei YQ, Wang XJ, Xiao F, Li SF, Zhang J. Growth inhibition and apoptosis induction of tanshinone II-A on human hepatocellular carcinoma cells. *World J Gastroenterol* 2004;10:2024–8.
26. Ugocsai K, Mandoky L, Tiszlavicz L, Molnar J. Effects of selected flavonoids and carotenoids on drug accumulation and apoptosis induction in multidrug-resistant colon cancer cells expressing MDR1/LRP. *In Vivo* 2005;19:433–8.
27. Efferth T. The human ATP-binding cassette transporter genes: from the bench to the bedside. *Curr Mol Med* 2001;1:45–65.
28. Efferth T, Grassmann R. Impact of viral oncogenesis on responses to anti-cancer drugs and irradiation. *Crit Rev Oncog* 2000;11:165–87.
29. Efferth T, Volm M. Pharmacogenetics for individualized cancer chemotherapy. *Pharmacol Ther* 2005;107:155–76.
30. Sladek NE. Leukemic cell insensitivity to cyclophosphamide and other oxazaphosphorines mediated by aldehyde dehydrogenase(s). *Cancer Treat Res* 2002;112:161–75.
31. Jeon SH, Kang MG, Kim YH, et al. A new mouse gene, SRG3, related to the SWI3 of *Saccharomyces cerevisiae*, is required for apoptosis induced by glucocorticoids in a thymoma cell line. *J Exp Med* 1997;185:1827–36.
32. Otsuki T, Furukawa Y, Ikeda K, et al. Fanconi anemia protein, FANCA, associates with BRG1, a component of the human SWI/SNF complex. *Hum Mol Genet* 2001;10:2651–60.
33. Jeong SM, Lee KY, Shin D, Chung H, Jeon SH, Seong RH. Nitric oxide inhibits glucocorticoid-induced apoptosis of thymocytes by repressing the SRG3 expression. *J Biol Chem* 2004;279:34373–9.
34. Kahl S. Zur Suche neuer Wirkstoffe mit Arzneimittelwirksamkeit in chinesischen Arzneipflanzen [dissertation]. Graz (Austria): University of Graz; 2005.